

2013

# COMMERCIAL





# DEPEND ON CHEVY

## FOR AWARD-WINNING VALUE



Somewhere in America, the day is beginning for millions of people who depend on a truck. At Chevrolet, we're proud to build commercial vehicles as dependable, hardworking and versatile as you are. Citing "lowest ownership costs," *Vincentric* named the 2012 Chevy Silverado HD and Express Van the "Best Fleet Values in America."<sup>1,2</sup> All across this land, you'll see Chevy trucks carrying the weight, building the bridges and working the family farms. Day in, day out, these are the award-winning trucks you can depend on.

Left to right: Silverado 3500HD Chassis Cab shown in Summit White with aftermarket dump body, Express 3500 Commercial Cutaway shown in Summit White with available features and aftermarket cube body, Silverado 3500HD Dually Crew Cab 4x4 shown in Silver Ice Metallic with available features and dealer-installed Chevy Accessories, and Express 1500 Cargo Van shown in Summit White with available features and dealer-installed Chevy Accessories.

<sup>1</sup> Based on the Vincentric 2012 awards analysis results for the Silverado 2500HD WT Reg. Cab 2WD LWB in the Full-Size Pickup, 3/4-ton segment. <sup>2</sup> Based on the Vincentric 2012 awards analysis results for the Express Cargo G1500 SWB in the Full-Size Cargo Van, 1/2-ton segment, and Express G1500 SWB in the Full-Size Passenger Van, 1/2-ton segment.

NOTE: The Silverado 3500HD Chassis Cab and Express 3500 Commercial Cutaway on this page, as well as many of the vehicles found throughout this catalog, have been altered or modified with equipment from independent suppliers. Chevrolet is not responsible for the safety or quality of design features, materials or workmanship of any alterations by such suppliers. See the last page for information about alterations and warranties.



# THE RIGHT TRUCK FOR EVERY JOB

Left to right: Suburban 3/4-ton shown in Summit White with available Fleet Package and other available features; Silverado 3500HD Dually Crew Cab LT 4x4 shown in Silver Ice Metallic with available features and dealer-installed Chevy Accessories; and Silverado 1500 Extended Cab LT 4x4 shown in Silver Ice Metallic with available features and dealer-installed Chevy Accessories.

CHEVY COMMERCIAL TRUCK MODEL	SERIES	CARGO BOX LENGTH	WHEELBASE (WB)	CAB-TO-AXLE LENGTH (IN.)	MAXIMUM PAYLOAD <sup>1</sup> (LBS.) 2WD/4x4	STANDARD ENGINE	STANDARD HP @ RPM LB.-FT. TORQUE @ RPM	OPTIONAL ENGINES
Tahoe	–	–	116.0"	–	1,633/1,606	Vortec™ 5.3L V8	320 @ 5400/335 @ 4000	–
Suburban	1/2-Ton	–	130.0"	–	1,526/1,580	Vortec 5.3L V8	320 @ 5400/335 @ 4000	–
	3/4-Ton	–	130.0"	–	2,459/2,187	Vortec 6.0L V8	352 @ 5400/382 @ 4200	–
Silverado Regular Cab	1500	6' 6"	119.0"	41.9"	1,940/1,714	Vortec 4.3L V6	195 @ 4600/260 @ 2800	Vortec 4.8L V8, Vortec 5.3L V8
	1500	8'	133.0"	55.9"	1,804/1,794	Vortec 4.3L V6	195 @ 4600/260 @ 2800	Vortec 4.8L V8, Vortec 5.3L V8
	2500HD	8'	133.7"	56.0"	4,212/3,538	Vortec 6.0L V8	360 @ 5400 <sup>2</sup> /380 @ 4200	Duramax® 6.6L Turbo-Diesel V8
	3500HD SRW <sup>3</sup>	8'	133.7"	56.0"	4,625/4,609	Vortec 6.0L V8	322 @ 4400/380 @ 4200	Duramax 6.6L Turbo-Diesel V8 (4x4)
	3500HD DRW <sup>4</sup>	8'	133.7"	56.0"	7,222/6,876	Vortec 6.0L V8	322 @ 4400/380 @ 4200	Duramax 6.6L Turbo-Diesel V8 (4x4)
Silverado Extended Cab	1500	6' 6"	143.5"	41.9"	1,908/1,835	Vortec 4.3L V6 (2WD) Vortec 4.8L V8 (4x4)	195 @ 4600/260 @ 2800 302 @ 5600/305 @ 4600	Vortec 4.8L V8 (2WD), Vortec 5.3L V8, Vortec 6.2L V8
	1500	8'	157.5"	55.5"	1,641/1,513	Vortec 5.3L V8	315 @ 5200/335 @ 4000	–
	2500HD	6' 6"	144.2"	41.6"	3,473/3,189	Vortec 6.0L V8	360 @ 5400 <sup>2</sup> /380 @ 4200	Vortec 6.0L V8 Bi-Fuel (CNG), Duramax 6.6L Turbo-Diesel V8
	2500HD	8'	158.2"	55.6"	3,358/3,275	Vortec 6.0L V8	360 @ 5400 <sup>2</sup> /380 @ 4200	Vortec 6.0L V8 Bi-Fuel (CNG), Duramax 6.6L Turbo-Diesel V8
	3500HD SRW <sup>3</sup>	8'	158.2"	55.6"	4,459/4,455	Vortec 6.0L V8	322 @ 4400/380 @ 4200	Duramax 6.6L Turbo-Diesel V8
	3500HD DRW <sup>4</sup>	8'	158.2"	55.6"	6,349/6,068	Vortec 6.0L V8	322 @ 4400/380 @ 4200	Duramax 6.6L Turbo-Diesel V8
Silverado Crew Cab	1500	5' 8"	143.5"	32.0"	1,937/1,890	Vortec 4.8L V8	302 @ 5600/305 @ 4600	Vortec 5.3L V8, Vortec 6.2L V8
	Hybrid <sup>5</sup>	5' 8"	143.5"	32.0"	1,527/1,509	Vortec 6.0L V8	332 @ 5100/367 @ 4100	–
	2500HD	6' 6"	153.7"	41.6"	3,347/3,066	Vortec 6.0L V8	360 @ 5400 <sup>2</sup> /380 @ 4200	Duramax 6.6L Turbo-Diesel V8
	2500HD	8'	167.7"	55.6"	3,247/3,305	Vortec 6.0L V8	360 @ 5400 <sup>2</sup> /380 @ 4200	Duramax 6.6L Turbo-Diesel V8
	3500HD SRW <sup>3</sup>	6' 6"	153.7"	41.6"	4,187/4,190	Vortec 6.0L V8	322 @ 4400/380 @ 4200	Duramax 6.6L Turbo-Diesel V8
	3500HD SRW <sup>3</sup>	8'	167.7"	55.6"	4,308/4,266	Vortec 6.0L V8	322 @ 4400/380 @ 4200	Duramax 6.6L Turbo-Diesel V8
	3500HD DRW <sup>4</sup>	8'	167.7"	55.6"	6,245/5,914	Vortec 6.0L V8	322 @ 4400/380 @ 4200	Duramax 6.6L Turbo-Diesel V8
Silverado Regular Cab Chassis Cab	3500HD	–	137.5"/162.0"	59.8"/84.3"	7,499/7,066 (59.8" CA) 7,294/6,954 (84.3" CA)	Vortec 6.0L V8	322 @ 4400/380 @ 4200	Duramax 6.6L Turbo-Diesel V8
Silverado Crew Cab Chassis Cab	3500HD	–	171.5"	59.4"	6,791/6,443	Vortec 6.0L V8	322 @ 4400/380 @ 4200	Duramax 6.6L Turbo-Diesel V8

<sup>1</sup> Maximum payload capacity includes weight of driver, passengers, optional equipment and cargo. <sup>2</sup> 322 hp @ 4400 rpm for Box Delete and incomplete vehicles. <sup>3</sup> Single rear wheel. <sup>4</sup> Dual rear wheel. <sup>5</sup> Available at participating dealers only.





Silverado Extended Cab Standard Box LT 4x4 shown in Blue Granite Metallic with available features and dealer-installed Chevy Accessories.

# SILVERADO DRIVES COSTS DOWN

## SILVERADO 1500

A commercial truck pays you back over time by staying on the road and getting the job done. "Silverado delivers the lowest cost of ownership of any full-size pickup,"<sup>1</sup> say the experts at *Vincentric*. The hardworking 2013 Silverado 1500 offers an available Vortec 6.2L V8 that generates 403 horses and 417 lb.-ft. of torque.

Extended Cab models with the available MAX Trailering Pack will tow up to 10,700 lbs.<sup>2</sup> Or haul up to 1,908 lbs. of payload.<sup>3</sup> And Silverado offers V8 fuel economy that's unsurpassed in its class.<sup>4</sup> Silverado — the most dependable, longest-lasting full-size pickups on the road.<sup>5</sup> And that's the bottom line.

<sup>1</sup>Based on Vincentric 2012 Model Level Analysis of 1/2-ton pickups in retail market. <sup>2</sup>Maximum trailer weight ratings are calculated assuming a base vehicle, except for any option(s) necessary to achieve the rating, plus driver. The weight of other optional equipment, passengers and cargo will reduce the maximum trailer weight your vehicle can tow. See your Chevy dealer for additional details. <sup>3</sup>Maximum payload capacity includes weight of driver, passengers, optional equipment and cargo. <sup>4</sup>Based on GM Large Pickup segment and EPA-estimated 15 MPG city/21 highway for Silverado with available 5.3L V8 engine when running on gasoline. <sup>5</sup>Dependability based on longevity: 1981–July 2011 full-size pickup registrations.

# SILVERADO 1500 HAS THE “LOWEST OWNERSHIP COST OF ANY FULL-SIZE PICKUP” – VINCENTRIC.COM

## SILVERADO 1500 SELECT SPECIFICATIONS

■ STANDARD □ AVAILABLE – NOT AVAILABLE

ENGINE AVAILABILITY	HP @ RPM	LB.-FT. TORQUE @ RPM	REGULAR CAB	EXTENDED CAB	CREW CAB
Vortec 4.3L V6	195 @ 4600	260 @ 2800	■ <sup>1</sup>	■ <sup>1</sup>	–
Vortec 4.8L FlexFuel <sup>2</sup> V8	302 @ 5600	305 @ 4600	■ <sup>3</sup>	■ <sup>4</sup>	■ <sup>5</sup>
Vortec 5.3L FlexFuel <sup>2</sup> V8	315 @ 5200	335 @ 4000	□	■ <sup>6</sup>	■ <sup>7</sup>
Vortec 6.2L FlexFuel <sup>2</sup> V8	403 @ 5700	417 @ 4300	–	□ <sup>8</sup>	□ <sup>8</sup>
TRANSMISSION/TRANSFER CASE AVAILABILITY			REGULAR CAB	EXTENDED CAB	CREW CAB
Hydra-Matic <sup>®</sup> 4-speed automatic with overdrive and Tow/Haul mode			■	■	■
Hydra-Matic 6-speed automatic with overdrive, Tap-Up/Tap-Down Driver Shift Control, auto grade braking and Tow/Haul mode <sup>9</sup>			□	□	□
Transfer case: 2-speed, floor-mounted (4x4)			■	■	■
Transfer case: Active, Autotrac <sup>®</sup> with electronic shift (4x4)			□	□	□
CHASSIS FEATURES			REGULAR CAB	EXTENDED CAB	CREW CAB
Alternator: 145-amp			■	■	■
160-amp <sup>10</sup>			□	–	–
Brakes: 4-wheel antilock with Dynamic Rear Proportioning			■	■	■
Front rotor diameter and thickness			13.0" x 1.2"	13.0" x 1.2"	13.0" x 1.2"
Rear drum diameter and width			11.6" x 2.4"	11.6" x 2.4"	11.6" x 2.4"
Front Gross Axle Weight Rating			3,200–3,950 lbs.	3,600–3,950 lbs.	3,650–3,950 lbs.
Rear Gross Axle Weight Rating			3,750–3,950 lbs.	3,750–4,200 lbs.	3,750–4,200 lbs.



## SILVERADO HYBRID<sup>11</sup>

Chevy Silverado Hybrid offers an EPA-estimated 20 MPG city/23 highway. And it has the power and performance you can count on: 332 horsepower, 367 lb.-ft. of torque, up to 6,100 lbs. of towing capability (2WD)<sup>12</sup> and a payload capacity of up to 1,527 lbs.<sup>13</sup>

<sup>1</sup> Work Truck only. Regular Cab Standard Box 2WD and 4x4, Regular Cab Long Box 2WD and 4x4, and Extended Cab Standard Box 2WD only. <sup>2</sup> E85 is a combination of 85% ethanol and 15% gasoline. Go to [chevy.com/biofuels](http://chevy.com/biofuels) to see if there is an E85 fuel station near you. When running on E85, Silverado 1500 with 4.8L V8 engine offers an EPA-estimated 10 MPG city/14 highway; Silverado 1500 with 5.3L V8 engine offers an EPA-estimated 11 MPG city/16 highway and Silverado 1500 with 6.2L V8 engine offers an EPA-estimated 9 MPG city/13 highway. <sup>3</sup> Standard on LT. <sup>4</sup> Standard on Standard Box LS and LT. <sup>5</sup> Standard on WT, LS and LT. <sup>6</sup> Standard on Standard Box LTZ and all Long Box models. <sup>7</sup> Standard on LTZ. <sup>8</sup> LT and LTZ only. <sup>9</sup> Requires available Vortec 5.3L V8 or Vortec 6.2L V8 engine. <sup>10</sup> Requires available Snow Plow Prep Package. <sup>11</sup> Available at participating dealers. <sup>12</sup> Maximum trailer weight ratings are calculated assuming a base vehicle, except for any option(s) necessary to achieve the rating, plus driver. The weight of other optional equipment, passengers and cargo will reduce the maximum trailer weight your vehicle can tow. See your Chevy dealer for additional details. <sup>13</sup> Maximum payload capacity includes weight of driver, passengers, optional equipment and cargo.





**OUR  
MOST POWERFUL  
HEAVY DUTY YET**

Silverado 3500HD Dually Regular Cab  
Long Box LT shown in Blue Granite Metallic  
with available features.

# SILVERADO 2500HD AND 3500HD, CONTINUING THE LOWEST COST OF OWNERSHIP

Silverado HD not only delivers on the toughest tasks. According to *Vincentric*,<sup>1</sup> it also delivers the lowest cost of ownership of any full-size pickup. And Chevy packs even more muscle into Silverado HD, making it our most powerful heavy duty yet. The available, proven Duramax 6.6L Turbo-Diesel V8 engine and renowned Allison<sup>®</sup> transmission deliver 397 horsepower and 765 lb.-ft. of torque, providing towing capabilities up to 23,100 lbs.<sup>2</sup> The Vortec 6.0L V8 gas engine with Variable Valve Timing (VVT) offers up to 360 horsepower<sup>3</sup> and 380 lb.-ft. of torque, and it's paired with a Hydra-Matic 6-speed automatic transmission. Three cab configurations, two box lengths, two drive types – 2WD and 4x4 – and both single and dual rear wheel options add up to 24 cab/box/drive/rear wheel combinations. With a high-strength, fully boxed steel frame that handles payloads up to 7,222 lbs.,<sup>4</sup> this is the strongest Silverado HD ever.

## SILVERADO 2500HD/3500HD SELECT SPECIFICATIONS

■ STANDARD □ AVAILABLE – NOT AVAILABLE

ENGINE AVAILABILITY	HP @ RPM	LB.-FT. TORQUE @ RPM	REGULAR CAB	EXTENDED CAB	CREW CAB
Vortec 6.0L FlexFuel <sup>5</sup> V8 (2500HD)	360 @ 5400 <sup>6</sup>	380 @ 4200	■	■	■
Vortec 6.0L V8 (Bi-Fuel CNG) Running on Gas	360 @ 5400	380 @ 4200	–	□ <sup>7</sup>	–
Vortec 6.0L V8 (Bi-Fuel CNG) Running on CNG	301 @ 5000	333 @ 4200	–	□ <sup>7</sup>	–
Vortec 6.0L FlexFuel <sup>5</sup> V8 (3500HD)	322 @ 4400	380 @ 4200	■	■	■
Duramax 6.6L Turbo-Diesel V8 <sup>8</sup>	397 @ 3000	765 @ 1600	□	□	□

TRANSMISSION/TRANSFER CASE AVAILABILITY	REGULAR CAB	EXTENDED CAB	CREW CAB
Hydra-Matic 6-speed automatic with overdrive, Tap-Up/Tap-Down Driver Shift Control, auto grade braking and Tow/Haul mode <sup>9</sup>	■	■	■
Allison 1000 Series 6-speed automatic with overdrive, Tap-Up/Tap-Down Driver Shift Control, auto grade braking and Tow/Haul mode <sup>10</sup>	□	□	□
Transfer case: 2-speed, floor-mounted (4x4)	■	■	■
Transfer case: Electronic-shift, instrument panel-mounted (4x4)	□	□	□

CHASSIS FEATURES	REGULAR CAB	EXTENDED CAB	CREW CAB
Alternator: 125-amp	■	■	■
Dual 125-amp <sup>11</sup>	□	□	□
160-amp <sup>12</sup>	□	□	□
Front Gross Axle Weight Rating	4,400–6,000 lbs.	4,400–6,000 lbs.	4,400–6,000 lbs.
Rear Gross Axle Weight Rating	6,200–9,825 lbs.	6,200–9,375 lbs.	6,200–9,375 lbs.



## AVAILABLE DURAMAX DIESEL POWER

The proven 397-horsepower Duramax 6.6L Turbo-Diesel V8 is teamed with the renowned Allison 6-speed automatic transmission.

<sup>1</sup> Based on Vincentric 2012 Model Level Analysis of 3/4-ton and 1-ton pickups in retail market. <sup>2</sup> Requires available diesel engine, fifth-wheel hitch and Regular Cab model. Maximum trailer weight ratings are calculated assuming a base vehicle, except for any option(s) necessary to achieve the rating, plus driver. The weight of other optional equipment, passengers and cargo will reduce the maximum trailer weight your vehicle can tow. See your Chevy dealer for additional details. <sup>3</sup> 322 horsepower on 3500HD and Box Delete models. <sup>4</sup> Requires Regular Cab model and gas engine. Maximum payload capacity includes weight of driver, passengers, optional equipment and cargo. <sup>5</sup> E85 is a combination of 85% ethanol and 15% gasoline. Go to [chevy.com/biofuels](http://chevy.com/biofuels) to see if there is an E85 fuel station near you. FlexFuel capability is not available when Pickup Box Delete is ordered. <sup>6</sup> 322 horsepower @ 4400 rpm for Box Delete and incomplete vehicles. <sup>7</sup> 2500HD models only. <sup>8</sup> Requires available Allison 1000 Series 6-speed automatic transmission. <sup>9</sup> Requires Vortec 6.0L V8 engine. <sup>10</sup> Requires available Duramax 6.6L Turbo-Diesel V8 engine. <sup>11</sup> Requires available Snow Plow Prep Package and Duramax 6.6L Turbo-Diesel V8 engine. <sup>12</sup> Requires Vortec 6.0L V8 engine and available Snow Plow Prep Package.



# INDUSTRIAL STRENGTH



## SILVERADO 2500HD AND 3500HD

There's no quitting time for an industrial-strength tool. Silverado HD Work Truck runs as hard and as long as you do. With a high-strength steel frame and wide rear leaf springs, Silverado 3500HD can handle up to 7,222 lbs. of payload.<sup>1</sup> The fully boxed frame is 30 times torsionally stronger than a Ford Super Duty.

<sup>1</sup> Requires Regular Cab model and gas engine. Maximum payload capacity includes weight of driver, passengers, optional equipment and cargo. Cargo and load capacity limited by weight and distribution. <sup>2</sup> Monthly rates apply. Visit [autonetmobile.com](http://autonetmobile.com) for details and coverage map.



## WI-FI BY AUTONET MOBILE

Equip an HD with the available dealer-installed Chevrolet Wi-Fi by Autonet Mobile<sup>2</sup> and every job site is a hot spot. It pays, literally, to have the right truck on the job.

Silverado 2500HD Regular Cab Long Box WT 4x4 shown in Summit White with available features.





## STABILITRAK ELECTRONIC STABILITY CONTROL SYSTEM

Standard on single rear wheel models, StabiliTrak® improves vehicle stability, particularly during emergency maneuvers. StabiliTrak automatically intervenes when it senses loss of lateral traction.



## TRAILER SWAY CONTROL

Working in conjunction with the StabiliTrak Electronic Stability Control System and Integrated Trailer Brake Control (if equipped), Trailer Sway Control (single rear wheel models) senses trailer sway and automatically applies the truck and trailer brakes and reduces engine power.



## HILL START ASSIST

On inclines greater than a 5% grade, Hill Start Assist (single rear wheel models) automatically engages to hold the truck stationary for about a second, allowing the driver time to press the accelerator pedal before the truck can roll backward.



## EXHAUST BRAKE SYSTEM

The diesel exhaust brake system on the available Duramax 6.6L Turbo-Diesel V8 engine works in conjunction with the Tow/Haul mode and auto grade braking. After adjusting for the load and grade, a variable vane geometry turbo creates back pressure to slow down the vehicle.



## BI-FUEL GAS OPTION

Continuing a commitment to cleaner, more efficient vehicles, Chevrolet is offering fleet and retail customers the new “bi-fuel” factory option on Silverado 2500HD Extended Cab models. The bi-fuel Silverado 2500HD has a specially designed Vortec 6.0L V8 engine and will be available in Standard and Long Box, with either 2-wheel or 4-wheel drive. It allows Silverado 2500HD to seamlessly switch between traditional gasoline and compressed natural gas (CNG) and provides a total range of more than 650 miles<sup>1</sup> without sacrificing the power or performance that have made the truck line legendary. The bi-fuel Silverado has a comprehensive 100,000-mile/5-year transferable Powertrain Limited Warranty<sup>2</sup>

<sup>1</sup> Estimated range based on GM testing and maximum tank capacity. Your range may be less.  
<sup>2</sup> Whichever comes first. See dealer for details.



## SNOW PLOW PREP PACKAGE

Every HD 4x4 model can easily accommodate a snow plow with the available Snow Plow Prep Package, thanks to massive forged and precision-machined upper control arms and a Front Gross Axle Weight Rating of up to 6,000 lbs.



# WORKS AS HARD AS YOU DO



Silverado 3500HD Chassis Cab shown in Silver Ice Metallic with a service body from an independent supplier.



# SILVERADO 3500HD CHASSIS CAB

A sturdy, dependable base. Deep down, nothing's more important in an upfitted vehicle. With Gross Vehicle Weight Ratings up to 13,200 lbs., Silverado Chassis Cab is the platform to build on. Two engine choices supply the power you expect – the standard Vortec 6.0L V8 and the available Duramax 6.6L Turbo-Diesel V8 that offers best-in-class HD Chassis Cab horsepower and torque. Heavy-duty automatic transmission options include the Hydra-Matic 6-speed paired with the Vortec V8 and the rugged Allison 1000 Series 6-speed mated to the Duramax Diesel. Standard features include auto grade braking, 4-wheel disc brakes with ABS and Dynamic Rear Proportioning. Whatever you build onto your truck, you want Chevy at the heart of it all.

## SILVERADO CHASSIS CAB SELECT SPECIFICATIONS

■ STANDARD □ AVAILABLE – NOT AVAILABLE

ENGINE AVAILABILITY	HP @ RPM	LB.-FT. TORQUE @ RPM	3500HD
Vortec 6.0L V8	322 @ 4400	380 @ 4200	■
Duramax 6.6L Turbo-Diesel V8	397 @ 3100	765 @ 1600	□
TRANSMISSION/TRANSFER CASE AVAILABILITY			3500HD
Hydra-Matic 6-speed automatic with overdrive, Tap-Up/Tap-Down Driver Shift Control, auto grade braking and Tow/Haul mode <sup>1</sup>			■
Allison 1000 Series 6-speed automatic with overdrive, Tap-Up/Tap-Down Driver Shift Control, auto grade braking and Tow/Haul mode <sup>2</sup>			□
Transfer case: 2-speed, floor-mounted <sup>3</sup> (4x4)			■
Transfer case: Electronic-shift, instrument panel-mounted (4x4)			□
CHASSIS FEATURES			3500HD
Alternator: 125-amp			■
Dual 125-amp <sup>4</sup>			□
160-amp <sup>5</sup>			□
Brakes: 4-wheel antilock disc with Dynamic Rear Proportioning			■
Front rotor diameter and thickness			13.9" x 1.6"
Rear rotor diameter and thickness			13.9" x 1.6"
Differential: Automatic locking rear			□
Steering: Power, recirculating ball			■
Front Gross Axle Weight Rating			4,400–6,000 lbs.
Rear Gross Axle Weight Rating			9,750 lbs.



## POWER TAKEOFF (PTO) CAPABILITY<sup>6</sup>

PTO capability allows HD Chassis Cab, with the available Duramax 6.6L Turbo-Diesel V8 engine, to power auxiliary equipment like a dump body or hydraulic motors for generators and tools. This feature runs off the available Allison 1000 Series 6-speed automatic transmission.

<sup>1</sup> Requires Vortec 6.0L V8 engine. <sup>2</sup> Requires available Duramax 6.6L Turbo-Diesel V8 engine. <sup>3</sup> Work Truck only. <sup>4</sup> Requires available Snow Plow Prep Package and Duramax 6.6L Turbo-Diesel V8 engine. <sup>5</sup> Requires Vortec 6.0L V8 engine and available Snow Plow Prep Package. <sup>6</sup> Additional equipment is required for PTO installation by an independent supplier. The provisions for PTO include an instrument panel switch, an electrical interface and an internal PTO gear in the transmission.



# IT MEANS BUSINESS



## **CAPTIVA SPORT COMPACT CROSSOVER**

The best fleet vehicles hold up better and stay in service longer. They also meet all the demands your job throws at you – plus the ones that haven't popped up yet. Captiva Sport is a contemporary 5-passenger crossover featuring versatility, roominess and efficiency, plus the power of an ECOTEC 2.4L 4-cylinder engine with a 6-speed automatic transmission.

StabiliTrak Electronic Stability Control System and Traction Control are standard. The 2013 Captiva Sport line includes LS, LT and uplevel LTZ versions. The LTZ has a rear vision camera, leather-appointed and heated front seats, 10-speaker sound system and sunroof. Available only for fleet customers.

Captiva Sport LS shown in Arctic Ice.



# REPORTING FOR DUTY



## TAHOE IS BIG – SUBURBAN IS BIGGER

These two have the room, power and capability few vehicles can match. Tahoe is available with Police and Special Service packages for standard patrol, hazmat, K-9, medical first responder or tactical operations. Both Tahoe and Suburban are available with a fleet package for other applications. Then there's Tahoe Hybrid! It's the most fuel-efficient full-size SUV in America.<sup>2</sup> The iconic Chevy Suburban is in a class by itself with available seating for up to nine and more cargo room than any competitor.

Tahoe shown with available Police Package, aluminum wheels and aftermarket equipment.

## TAHOE SPECIAL SERVICE VEHICLE

The Vortec 5.3L V8 engine is E85 FlexFuel-capable.<sup>3</sup> Paired with a standard 6-speed automatic transmission, it allows Tahoe to tow up to 8,200 lbs.<sup>4</sup> Electric Trailer Sway Control and Hill Start Assist are standard.

<sup>1</sup> Available at participating dealers. <sup>2</sup> EPA-estimated 20 MPG city/23 highway. Based on GM Large Utility segment. <sup>3</sup> E85 is a combination of 85% ethanol and 15% gasoline. Go to [chevy.com/biofuels](http://chevy.com/biofuels) to see if there is an E85 fuel station near you. When running on E85, Tahoe offers an EPA-estimated 11 MPG city/16 highway. <sup>4</sup> Maximum trailer weight ratings are calculated assuming a base vehicle, except for any option(s) necessary to achieve the rating, plus driver. The weight of other optional equipment, passengers and cargo will reduce the maximum trailer weight your vehicle can tow. See your Chevy dealer for additional details.



# CHEVY EXPRESS

## YOUR DEPENDABLE BUSINESS PARTNER

Vincentric has honored Chevy Express for delivering “the lowest cost of ownership of any full-size van for 5 years running.”<sup>1</sup> And a wide selection of models makes it the right choice for your commercial transport needs.

Left to right: Express 3500 Commercial Cutaway shown in Summit White with available features and an aftermarket cube body; Express 1500 Cargo Van shown in Summit White with available features and aftermarket accessories; Express 3500 Extended Wheelbase Passenger Van shown in Sheer Silver Metallic.

CHEVY COMMERCIAL VAN MODEL	TRIM/SERIES	DRIVE	WHEELBASE (WB)	STANDARD ENGINE	STANDARD HP @ RPM/ LB.-FT. TORQUE @ RPM	OPTIONAL ENGINES	MAXIMUM PAYLOAD <sup>2</sup>	CARGO SPACE <sup>3</sup> (CU. FT.)	STANDARD SEATING	OPTIONAL SEATING
Express Cargo Van	1500	RWD	135"	Vortec 4.3L V6	195 @ 4600/260 @ 2800	Vortec 5.3L V8	2,360 lbs.	239.7	2	1
	1500 AWD	AWD	135"	Vortec 5.3L V8	310 @ 5200/334 @ 4500	—	1,995 lbs.	239.7	2	1
	2500 Regular	RWD	135"	Vortec 4.8L V8	280 @ 5200/295 @ 4600	Vortec 6.0L V8, Vortec 6.0L V8 (CNG), Duramax 6.6L Turbo-Diesel V8	3,287 lbs.	239.7	2	1
	2500 Extended	RWD	155"	Vortec 4.8L V8	280 @ 5200/295 @ 4600	Duramax 6.6L Turbo-Diesel V8	3,073 lbs.	284.4	2	1
	3500 Regular	RWD	135"	Vortec 4.8L V8	280 @ 5200/295 @ 4600	Vortec 6.0L V8, Vortec 6.0L V8 (CNG), Duramax 6.6L Turbo-Diesel V8	4,186 lbs.	239.7	2	1
	3500 Extended	RWD	155"	Vortec 4.8L V8	280 @ 5200/295 @ 4600	Vortec 6.0L V8 Duramax 6.6L Turbo-Diesel V8	4,011 lbs.	284.4	2	1
Express Commercial Cutaway	3500	RWD	139"/159"	Vortec 4.8L V8 <sup>4</sup>	280 @ 5200/295 @ 4600	Vortec 6.0L V8 Duramax 6.6L Turbo-Diesel V8	7,307 lbs./ 7,310 lbs.	—	2	1
	3500	RWD	177"	Vortec 6.0L V8	324 @ 4700/373 @ 4400	Duramax 6.6L Turbo-Diesel V8	7,248 lbs.	—	2	1
	4500	RWD	159"/177"	Vortec 6.0L V8	324 @ 4700/373 @ 4400	Vortec 6.0L V8 (LPG) (159" WB only) Duramax 6.6L Turbo-Diesel V8	9,156 lbs./ 7,796 lbs.	—	2	1
Express Passenger Van	1500	RWD	135"	Vortec 5.3L V8	310 @ 5200/334 @ 4500	—	1,779 lbs.	216.2 <sup>5</sup>	8	—
	1500 AWD	AWD	135"	Vortec 5.3L V8	310 @ 5200/334 @ 4500	—	1,560 lbs.	216.2 <sup>5</sup>	8	—
	2500	RWD	135"	Vortec 4.8L V8	280 @ 5200/295 @ 4600	Vortec 6.0L V8	2,705 lbs.	216.2 <sup>5</sup>	12	8
	3500 Regular	RWD	135"	Vortec 4.8L V8	280 @ 5200/295 @ 4600	Vortec 6.0L V8, Duramax 6.6L Turbo-Diesel V8	3,491 lbs.	216.2 <sup>5</sup>	12	8
	3500 Extended	RWD	155"	Vortec 4.8L V8	280 @ 5200/295 @ 4600	Vortec 6.0L V8, Duramax 6.6L Turbo-Diesel V8	3,171 lbs.	252.8 <sup>5</sup>	12	15

<sup>1</sup> Based on Vincentric 2012 Model Level Analysis. <sup>2</sup> Maximum payload capacity includes weight of driver, passengers, optional equipment and cargo. Higher payloads (where available) require optional equipment. <sup>3</sup> Cargo and load capacity limited by weight and distribution. <sup>4</sup> On vehicles weighing less than 10,000 lbs. <sup>5</sup> With all rear passenger seats removed.



# THE BEST POWERTRAIN CHOICES OF ANY FULL-SIZE VAN

## EXPRESS CARGO VAN 1500, 2500 AND 3500

It isn't just a van, it's how you work. And you work with the right tools for the job. That's why Express Cargo Van offers an unmatched selection of engines, ranging from the fuel-conscious Vortec 4.3L V6 with an EPA-estimated 20 MPG highway to an extensive lineup of Vortec V8 powerplants — all the way up to the Duramax 6.6L

Turbo-Diesel V8, the most powerful diesel in its class. A standard Hydra-Matic 6-speed automatic transmission on 2500 and 3500 models includes Tap-Up/Tap-Down Driver Shift Control and auto grade braking. When you're ready to get down to business, get a Chevy Express.

Express Cargo Van 1500 AWD shown in Summit White with available features.

# CHEVY EXPRESS CARGO VANS

Cargo Vans offer a variety of fuel options. Choose from models powered by gasoline, diesel (with the available Duramax Turbo-Diesel V8) or compressed natural gas (CNG). The available Vortec 4.8L, 5.3L and 6.0L engines can operate on either regular unleaded gasoline, E85<sup>1</sup> – a blend of 85% ethanol and 15% gasoline – or a combination of both. See [chevy.com](http://chevy.com) for more information.

## EXPRESS CARGO VAN SELECT SPECIFICATIONS

■ STANDARD □ AVAILABLE – NOT AVAILABLE

ENGINE AVAILABILITY	HP @ RPM	LB.-FT. TORQUE @ RPM	1500	1500 AWD	2500	2500 EXT	3500	3500 EXT
Vortec 4.3L V6	195 @ 4600	260 @ 2800	■	–	–	–	–	–
Vortec 4.8L FlexFuel <sup>1</sup> V8	280 @ 5200	295 @ 4600	–	–	■	■	■	■
Vortec 5.3L FlexFuel <sup>1</sup> V8	310 @ 5200	334 @ 4500	□	■	–	–	–	–
Vortec 6.0L FlexFuel <sup>1</sup> V8	324 @ 4700	373 @ 4400	–	–	□	□	□	□
Vortec 6.0L V8 (CNG)	279 @ 4700	320 @ 4400	–	–	□	–	□	–
Duramax 6.6L Turbo-Diesel V8	260 @ 3100	525 @ 1600	–	–	□	□	□	□
TRANSMISSION/TRANSFER CASE AVAILABILITY			1500	1500 AWD	2500	2500 EXT	3500	3500 EXT
Hydra-Matic 4-speed automatic with overdrive and Tow/Haul mode			■	■	–	–	–	–
Hydra-Matic 6-speed automatic with overdrive, Tap-Up/Tap-Down Driver Shift Control, auto grade braking and Tow/Haul mode			–	–	■	■	■	■
CHASSIS FEATURES			1500	1500 AWD	2500	2500 EXT	3500	3500 EXT
Alternator: 125-amp			□ <sup>2</sup>	■	–	–	–	–
145-amp			■ <sup>3</sup>	–	□ <sup>4</sup>	□ <sup>4</sup>	□ <sup>4</sup>	□ <sup>4</sup>
105-amp			–	–	■	■	■	■
Dual 145-amp <sup>5</sup>			–	–	□	□	□	□
Battery: 600-cca <sup>6</sup>			■	■	■	■	■	■
High-capacity 770-cca <sup>6</sup>			□	□	□ <sup>7</sup>	□ <sup>7</sup>	□ <sup>7</sup>	□ <sup>7</sup>
Brakes: Power, hydraulic 4-wheel ventilated disc			■	■	■	■	■	■
4-wheel antilock with Dynamic Rear Proportioning			■	■	■	■	■	■
Front rotor diameter and thickness			12.0" x 1.1"	12.0" x 1.1"	12.8" x 1.5"	12.8" x 1.5"	12.8" x 1.5"	12.8" x 1.5"
Rear rotor diameter and thickness			13.0" x 1.2"	13.0" x 1.2"	13.0" x 1.1"	13.0" x 1.1"	13.0" x 1.1"	13.0" x 1.1"
Differential: Automatic locking rear			□	□	□	□	□	□
Front Gross Axle Weight Rating			3,600 lbs.	3,700 lbs.	4,100 lbs.	4,300 lbs.	4,600 lbs.	4,600 lbs.
Rear Gross Axle Weight Rating			4,000 lbs.	4,000 lbs.	5,360 lbs.	5,360 lbs.	6,084 lbs.	6,084 lbs.



PROTECTED AND CONNECTED. With OnStar<sup>®8</sup> experience the safe, simple way to stay connected on the road.

OnStar is now standard on all Passenger Van models – available on Cargo Van and Commercial Cutaway – with the Directions & Connections<sup>®</sup> Plan for the first six months.

<sup>1</sup> E85 is a combination of 85% ethanol and 15% gasoline. Go to [chevy.com/biofuels](http://chevy.com/biofuels) to see if there is an E85 fuel station near you. <sup>2</sup> Requires available Vortec 5.3L V8 engine. <sup>3</sup> Standard with Vortec 4.3L V6 engine. <sup>4</sup> Standard with Duramax 6.6L Turbo-Diesel V8 engine. <sup>5</sup> Requires available Duramax 6.6L Turbo-Diesel V8 engine and air conditioning. <sup>6</sup> Cold-cranking amps. <sup>7</sup> Duramax 6.6L Turbo-Diesel V8 engine comes with standard dual 770-cca batteries. <sup>8</sup> Visit [onstar.com](http://onstar.com) for coverage map, details and system limitations. Services vary by model and conditions. <sup>9</sup> Estimated range based on GM testing and maximum tank capacity. Your range may be less. <sup>10</sup> Whichever comes first. See dealer for details.



## AVAILABLE ACCESS PACKAGES

These packages offer easy interior access to tools and cargo. Each includes three exterior, remote-release, side-access panels that can be opened by Remote Keyless Entry. Not available with optional driver-side 60/40 swing-out doors or sliding passenger-side door.



## NEW COMPRESSED NATURAL GAS (CNG) OPTION ON EXPRESS

Express 2500 and 3500 Cargo Vans with the CNG option are available with a 3-tank or 4-tank system. The 3-tank system provides a range of up to approximately 200 miles,<sup>9</sup> while the 4-tank system provides a range of up to 300 miles.<sup>9</sup> GM is the only manufacturer with a fully integrated CNG option for vans and offers a 5-year/100,000-mile transferable Powertrain Limited Warranty<sup>10</sup> on Express Cargo Vans with CNG.



# SAFETY DRIVES US

Express 1500 Cargo Van shown in Sheer Silver Metallic with available features.



## CHEVY EXPRESS

When you're transporting people for a living, safety is paramount. The Chevy Express Passenger Van offers standard safety features such as head-curtain side-impact air bags,<sup>1</sup> the StabiliTrak Electronic Stability Control System, a Tire Pressure Monitoring System (except spare tire) and antilock brakes. Enhanced Technology Glass (ETG)<sup>2</sup> for a quiet ride is standard on 12- and 15-passenger models. And you can easily tailor the Express Van to your exact needs with a choice of 8-, 12- and 15-passenger seating configurations, depending on model.

<sup>1</sup> Always use safety belts and the correct restraint for your child's age and size. Even in vehicles equipped with the Passenger Sensing System, children are safer when properly secured in a rear seat in the appropriate infant, child or booster seat. Never place a rear-facing infant restraint in the front seat of any vehicle equipped with a passenger air bag. See the Owner's Manual and the child safety seat instructions for more safety information. <sup>2</sup> ETG is part of the overall occupant protection system on Passenger Vans. ETG may help keep passengers sitting next to these windows from being ejected through the glass in some, but not all, crashes. Even with this glass, safety belts must be worn at all times. For Passenger Vans, use only ETG glass approved for your vehicle for replacement when damaged. Standard with Duramax 6.6L Turbo-Diesel V8.



## REAR VISION CAMERA AND REAR PARK ASSIST

An available integral rear vision camera and Rear Park Assist help you detect certain stationary objects located behind the vehicle when traveling in reverse at low speeds.



# EXPRESS PASSENGER VAN 1500, 1500 AWD, 2500, 3500 AND 3500 EXT

EXPRESS PASSENGER VAN SELECT SPECIFICATIONS			■ STANDARD	□ AVAILABLE	– NOT AVAILABLE		
ENGINE AVAILABILITY	HP @ RPM	LB.-FT. TORQUE @ RPM	1500	1500 AWD	2500	3500	3500 EXT
Vortec 5.3L FlexFuel <sup>1</sup> V8	310 @ 5200	334 @ 4500	■	■	–	–	–
Vortec 4.8L FlexFuel <sup>1</sup> V8	280 @ 5200	295 @ 4600	–	–	■	■	■
Vortec 6.0L FlexFuel <sup>1</sup> V8	324 @ 4700	373 @ 4400	–	–	□	□	□
Duramax 6.6L Turbo-Diesel V8	260 @ 3100	525 @ 1600	–	–	–	□	□
TRANSMISSION/TRANSFER CASE AVAILABILITY			1500	1500 AWD	2500	3500	3500 EXT
Hydra-Matic 4-speed automatic with overdrive and Tow/Haul mode			■	■	–	–	–
Hydra-Matic 6-speed automatic with overdrive, Tap-Up/Tap-Down Driver Shift Control, auto grade braking and Tow/Haul mode			–	–	■	■	■
CHASSIS FEATURES			1500	1500 AWD	2500	3500	3500 EXT
All-Wheel Drive (AWD)			–	■	–	–	–
Alternator: 105-amp			–	–	■	■	–
125-amp			■	■	–	–	–
145-amp			□ <sup>2</sup>	□ <sup>2</sup>	□ <sup>2</sup>	□ <sup>2</sup>	■
Brakes: Power, hydraulic 4-wheel ventilated disc			■	■	■	■	■
4-wheel antilock with Dynamic Rear Proportioning			■	■	■	■	■
Front rotor diameter and thickness			12.0" x 1.1"	12.0" x 1.1"	12.8" x 1.5"	12.8" x 1.5"	12.8" x 1.5"
Rear rotor diameter and thickness			13.0" x 1.2"	13.0" x 1.2"	13.0" x 1.1"	13.0" x 1.6"	13.0" x 1.6"
Oil-Life Monitor			■	■	■	■	■
StabiliTrak Electronic Stability Control System			■	■	■	■	■
Steering: Power			■	■	■	■	■
Front Gross Axle Weight Rating			3,600 lbs.	3,700 lbs.	4,100 lbs.	4,600 lbs.	4,600 lbs.
Rear Gross Axle Weight Rating			4,000 lbs.	4,000 lbs.	5,360 lbs.	6,084 lbs.	6,084 lbs.



## MOBILITY VEHICLES

We want to make it easy and safe for people with special needs (and those who care for them) to travel. Express provides abundant interior space and accessibility that wheelchair and scooter users appreciate. Express is a practical choice for mobility and paratransit conversions. It's designed to allow easy installation of adaptive equipment and mobility accessories like wheelchair lifts, ramps, running boards and driver aids, available from independent aftermarket suppliers.<sup>3</sup>

<sup>1</sup> E85 is a combination of 85% ethanol and 15% gasoline. Go to [chevy.com/biofuels](http://chevy.com/biofuels) to see if there is an E85 fuel station near you. <sup>2</sup> Requires available rear air conditioning. Standard on LT trim level. <sup>3</sup> GM is not responsible for the safety or quality of design features, materials or workmanship of any alterations by such a supplier.



# EXPRESS 3500 AND 4500 CUTAWAY

Express Commercial Cutaways are built on a proven foundation with a full-length, ladder-type frame designed for upfitting. Three wheelbases are available: 139-inch, 159-inch and 177-inch. Vortec V8 power is standard, along with a Hydra-Matic 6-speed automatic transmission that includes auto grade braking and Tow/Haul mode. The available Duramax 6.6L Turbo-Diesel V8 is the most powerful diesel in its class. The Express Commercial Cutaway is designed to meet many requirements – every one of which starts with the power, strength and dependability of a proven Chevrolet chassis.

## EXPRESS COMMERCIAL CUTAWAY SELECT SPECIFICATIONS

■ STANDARD □ AVAILABLE – NOT AVAILABLE

ENGINE AVAILABILITY	HP @ RPM	LB.-FT. TORQUE @ RPM	139" WHEELBASE (3500)	159" WHEELBASE (3500)	177" WHEELBASE (3500)	159" WHEELBASE (4500)	177" WHEELBASE (4500)
Vortec 4.8L V8	280 @ 5200	295 @ 4600	■	■	–	–	–
Vortec 6.0L V8	324 @ 4700	373 @ 4400	□	□	■	■	■
Vortec 6.0L V8 (LPG)	332 @ 4800	370 @ 4400	–	–	–	□	–
Duramax 6.6L Turbo-Diesel V8	260 @ 3100	525 @ 1600	□	□	□	□	□
TRANSMISSION/TRANSFER CASE AVAILABILITY			139" WHEELBASE (3500)	159" WHEELBASE (3500)	177" WHEELBASE (3500)	159" WHEELBASE (4500)	177" WHEELBASE (4500)
Hydra-Matic 6-speed automatic with overdrive, Tap-Up/Tap-Down Driver Shift Control, auto grade braking and Tow/Haul mode			■	■	■	■	■
CHASSIS FEATURES			139" WHEELBASE (3500)	159" WHEELBASE (3500)	177" WHEELBASE (3500)	159" WHEELBASE (4500)	177" WHEELBASE (4500)
Alternator: 145-amp			■	■	■	■	■
Dual 145-amp			□ <sup>1</sup>	□ <sup>1</sup>	□ <sup>1</sup>	□ <sup>1</sup>	□ <sup>1</sup>
Battery: 600-cca <sup>2</sup>			■	■	■	■	■
High-capacity 770-cca <sup>2</sup>			□ <sup>3</sup>	□ <sup>3</sup>	□ <sup>3</sup>	□ <sup>3</sup>	□ <sup>3</sup>
Brakes: power, hydraulic 4-wheel ventilated disc			■	■	■	■	■
4-wheel antilock with Dynamic Rear Proportioning			■	■	■	■	■
Front rotor diameter and thickness			12.8" x 1.5"	13.0" x 1.1"	13.0" x 1.1"	13.0" x 1.1"	13.0" x 1.1"
Rear rotor diameter and thickness			12.8" x 1.8"	13.58" x 1.6"	13.58" x 1.6"	13.58" x 1.6"	13.58" x 1.6"
Differential: Automatic locking rear			□	□	■	□	–
Oil-Life Monitor			■	■	■	■	■
Steering: Power			■	■	■	■	■
Suspension, front: independent with 35mm tubular stabilizer and coil springs			■	■	■	■	■
Axle capacity			4,300 lbs.	4,100 lbs.	4,600 lbs.	4,600 lbs.	4,600 lbs.
Suspension, rear: hypoid drive axle with multileaf springs			■	■	■	■	■
Axle capacity (standard GVWR)			6,084 lbs.	7,500 lbs.	8,600 lbs.	9,600 lbs.	9,600 lbs.



<sup>1</sup> Requires available Duramax 6.6L Turbo-Diesel V8 engine. <sup>2</sup> Cold-cranking amps. <sup>3</sup> Duramax 6.6L Turbo-Diesel V8 engine comes with standard dual 770-cca batteries.





## LIQUEFIED PETROLEUM GAS (LPG)

LPG vehicles make business sense for many fleets. That's why the LPG option is now available on Express 4500 Cutaway Vans in a 3-tank or 4-tank system. The vehicle is built with a gaseous fuel-ready 6.0L Vortec V8 engine with factory-installed hardened exhaust valves and intake/exhaust valve seats. Engineered by GM, all components meet GM standards for safety, reliability and durability, and are backed by a comprehensive 5-year/100,000-mile transferable Powertrain Limited Warranty!<sup>1</sup> Visit [chevy.com](http://chevy.com) for more information.

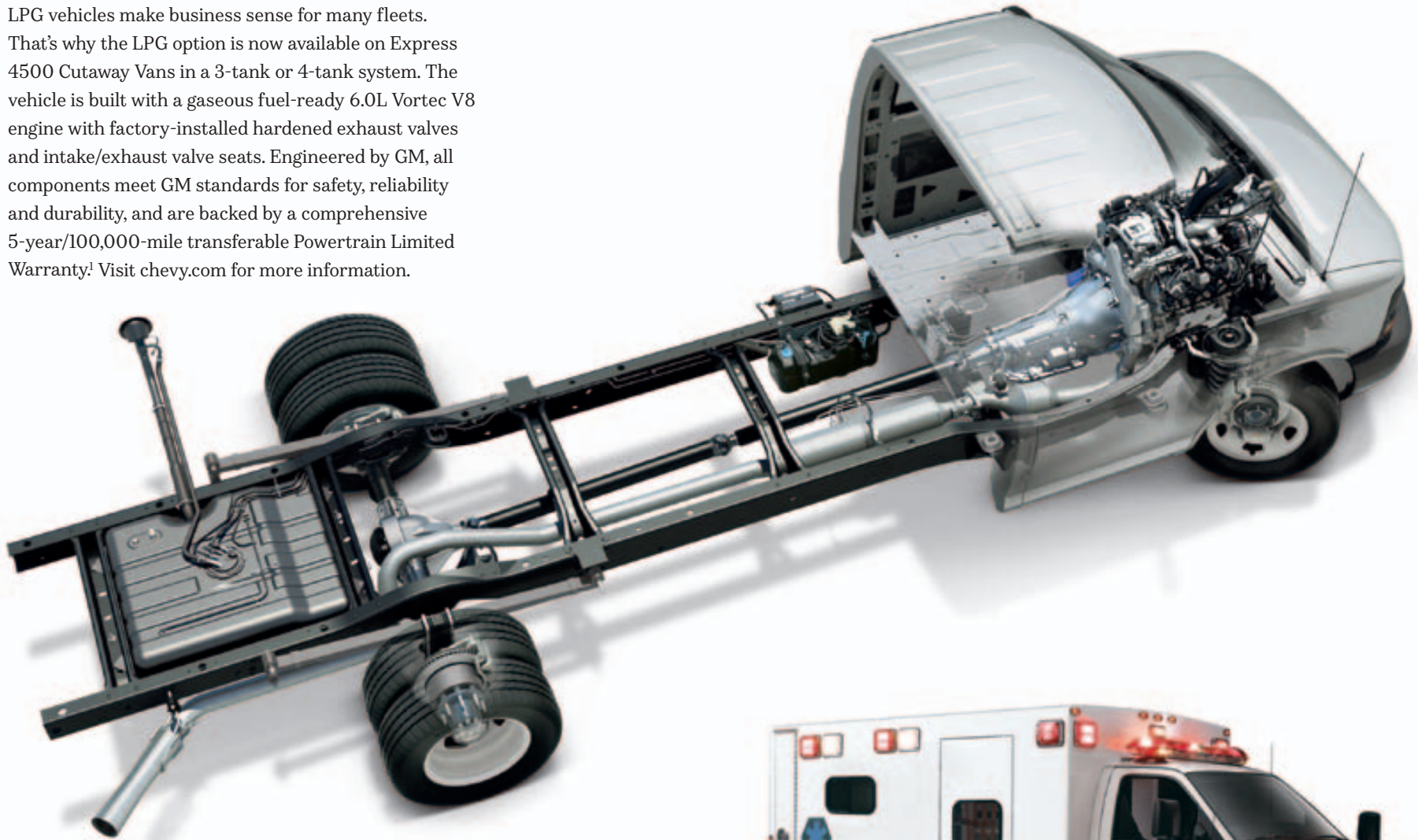

## EXPRESS 4500 COMMERCIAL CUTAWAY

Express 4500 Commercial Cutaway offers 159-inch and the new 177-inch wheelbase options. It's the perfect platform for numerous upfits, including a school bus,<sup>2</sup> ambulance, shuttle bus<sup>2</sup> or recreational vehicle.



<sup>1</sup> Whichever comes first. See dealer for details. <sup>2</sup> Not available on 177-inch wheelbase models.



# COMMERCIAL VEHICLE DIMENSIONS

## SILVERADO

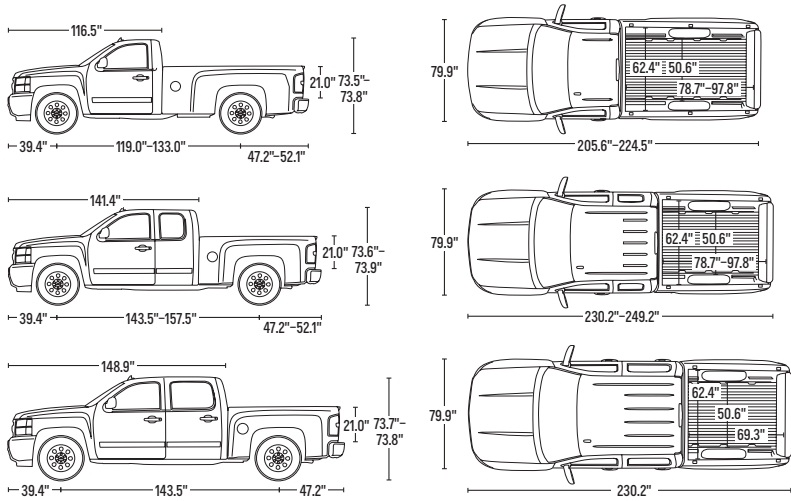

## SILVERADO HD

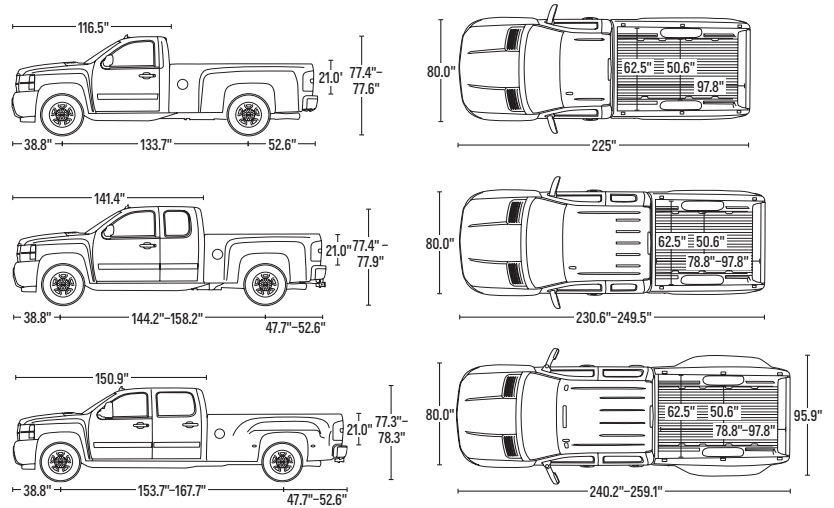

## SILVERADO 3500HD REGULAR CAB CHASSIS CAB

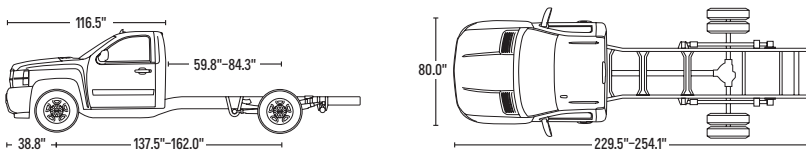

## SUBURBAN

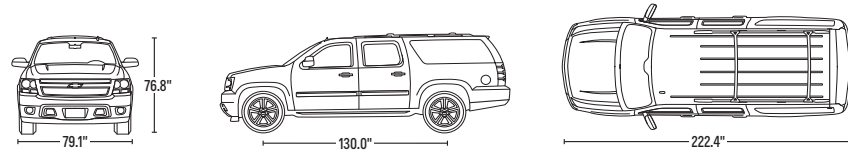

## SILVERADO 3500HD CREW CAB CHASSIS CAB

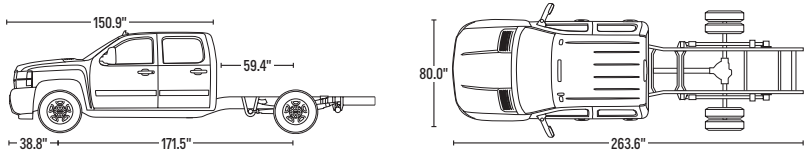

## TAHOE

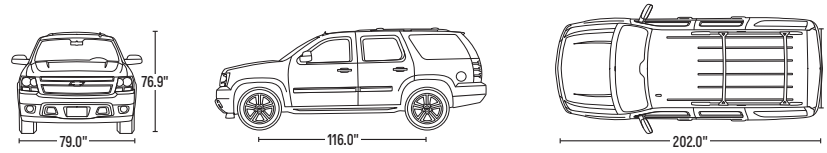

## EXPRESS CARGO VAN 135.0" Wheelbase/155.0" Wheelbase

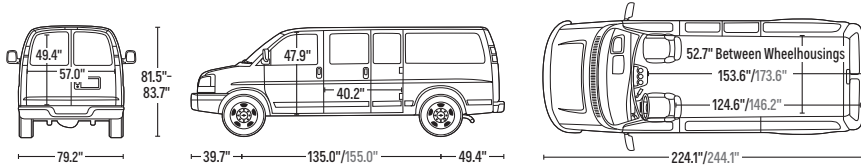

## CAPTIVA SPORT

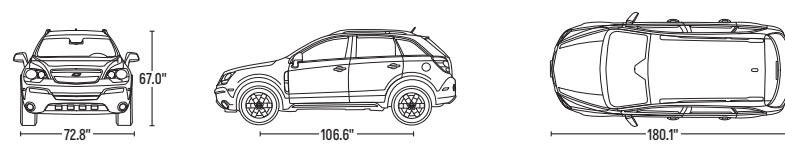

## EXPRESS COMMERCIAL CUTAWAY 139.0" Wheelbase/159.0" Wheelbase/177.0" Wheelbase

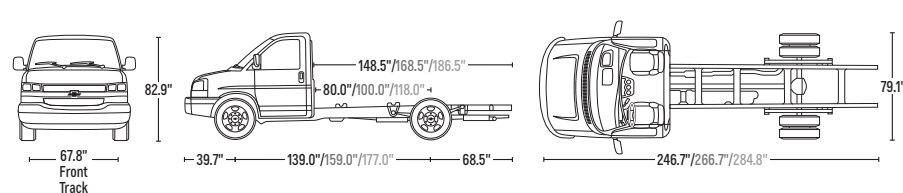

## EXPRESS PASSENGER VAN 135.0" Wheelbase/155.0" Wheelbase

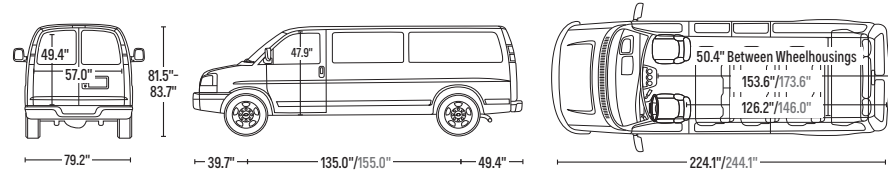

NOTE: For a complete list of all Commercial Vehicle dimensions and specifications, go to [chevy.com](http://chevy.com).



## SILVERADO 1500 CONVENTIONAL TRAILER WEIGHT RATINGS<sup>1</sup>

ENGINE	AXLE RATIO	GCWR <sup>2</sup>	REGULAR CAB				EXTENDED CAB				CREW CAB	
			STANDARD BOX 2WD	LONG BOX 2WD	STANDARD BOX 4x4	LONG BOX 4x4	STANDARD BOX 2WD	LONG BOX 2WD	STANDARD BOX 4x4	LONG BOX 4x4	SHORT BOX 2WD	SHORT BOX 4x4
Vortec 4.3L V6	3.73	10,000	5,400	5,200	5,100	4,900	-	-	-	-	-	-
	3.23	9,500	4,800	4,700	-	-	4,400	-	-	-	-	-
Vortec 4.8L V8	3.73	12,000	7,200	7,100	-	-	6,700	-	-	-	6,700	-
	3.42	11,000	-	-	6,000	5,800	-	-	5,500	-	-	5,500
	3.23	10,000	-	5,100	-	-	4,700	-	-	-	4,700	-
	3.23	9,500	4,700	-	-	-	-	-	-	-	-	-
Vortec 5.3L V8 with Heavy-Duty Cooling Package	3.42	15,000	-	10,000	-	9,800	9,700	9,500	9,600	9,300	9,600	9,500
	3.42	14,000	9,100	-	8,900	-	-	-	-	-	-	-
	3.08	12,200	7,400	7,200	7,100	7,000	6,900	6,700	6,800	6,500	6,900	6,700
Vortec 5.3L V8 XFE	3.08	12,200	-	-	-	-	-	-	-	-	7,000	-
Vortec 5.3L V8	3.08	11,500	6,600	6,500	6,400	6,300	6,200	6,000	6,100	5,800	6,200	6,000
Vortec 6.0L V8 Hybrid	3.08	12,000	-	-	-	-	-	-	-	-	6,100	5,900
Vortec 6.2L V8 with MAX Trailering Pack	3.73	16,000	-	-	-	-	10,700	-	10,400	-	10,600	10,400
Vortec 6.2L V8	3.42	15,000	-	-	-	-	9,700	-	9,400	-	9,700	9,400

## SILVERADO 2500HD AND 3500HD CONVENTIONAL TRAILER WEIGHT RATINGS<sup>1</sup>

REGULAR CAB											
ENGINE	AXLE RATIO	GCWR <sup>2</sup>	2500HD LONG BOX 2WD	3500HD LONG BOX 2WD	3500HD LONG BOX 2WD DUALY	2500HD LONG BOX 4x4	3500HD LONG BOX 4x4	3500HD LONG BOX 4x4 DUALY			
Vortec 6.0L V8	4.10	20,500	13,000	13,000	14,100	13,000	13,000	13,800			
	3.73	16,000	10,200	-	9,600	9,900	9,700	9,300			
Duramax 6.6L Turbo-Diesel V8	3.73	24,500	13,000	-	-	13,000	13,000	-			
	3.73	30,500	-	-	-	-	-	16,000			

EXTENDED CAB											
ENGINE	AXLE RATIO	GCWR <sup>2</sup>	2500HD STANDARD BOX 2WD	2500HD LONG BOX 2WD	3500HD LONG BOX 2WD	3500HD LONG BOX 2WD DUALY	2500HD STANDARD BOX 4x4	2500HD LONG BOX 4x4	3500HD LONG BOX 4x4	3500HD LONG BOX 4x4 DUALY	
Vortec 6.0L V8	4.10	20,500	13,000	13,000	13,000	13,600	13,000	13,000	13,000	13,000	13,400
	3.73	16,000	9,800	9,700	9,500	9,100	9,500	9,400	9,200	8,900	
Vortec 6.0L V8 Compressed Natural Gas (CNG)	4.10	20,500	13,000	13,000	-	-	13,000	13,000	-	-	
	3.73	16,000	9,300	9,200	-	-	9,000	8,900	-	-	
Duramax 6.6L Turbo-Diesel V8	3.73	24,500	13,000	13,000	13,000	-	13,000	13,000	13,000	-	
	3.73	30,500	-	-	-	16,500	-	-	-	18,000	

CREW CAB												
ENGINE	AXLE RATIO	GCWR <sup>2</sup>	2500HD STANDARD BOX 2WD	2500HD LONG BOX 2WD	3500HD STANDARD BOX 2WD	3500HD LONG BOX 2WD	3500HD LONG BOX 2WD DUALY	2500HD STANDARD BOX 4x4	2500HD LONG BOX 4x4	3500HD STANDARD BOX 4x4	3500HD LONG BOX 4x4	3500HD LONG BOX 4x4 DUALY
Vortec 6.0L V8	4.10	20,500	13,000	13,000	13,000	13,000	13,500	13,000	13,000	13,000	13,000	13,200
	3.73	16,000	9,700	9,600	9,500	9,400	9,000	9,400	9,300	9,200	9,100	8,700
Duramax 6.6L Turbo-Diesel V8	3.73	24,500	13,000	13,000	13,000	13,000	-	13,000	13,000	13,000	13,000	-
	3.73	30,500	-	-	-	-	16,500	-	-	-	-	18,000

<sup>1</sup> Maximum trailer weight ratings are calculated assuming a base vehicle, except for any option(s) necessary to achieve the rating, plus driver. The weight of other optional equipment, passengers and cargo will reduce the maximum trailer weight your vehicle can tow. See your Chevy dealer for additional details. <sup>2</sup> Gross Combination Weight Rating.



## SILVERADO 1500 FIFTH-WHEEL TRAILER WEIGHT RATINGS<sup>1</sup>

Fifth-wheel trailering with a Silverado 1500 requires Z85 Handling/Trailer suspension or Z71 Off-Road suspension. Please read the Trailering Basics on the next page before towing a trailer with any Chevy truck.

ENGINE	AXLE RATIO	GCWR <sup>2</sup>	REGULAR CAB			EXTENDED CAB			
			LONG BOX 2WD	STANDARD BOX 4x4	LONG BOX 4x4	STANDARD BOX 2WD	LONG BOX 2WD	STANDARD BOX 4x4	LONG BOX 4x4
Vortec 5.3L V8 with Heavy-Duty Cooling Package	3.42	15,000	8,900	-	9,700	9,400	9,000	9,600	8,100
	3.42	14,000	-	8,200	-	-	-	-	-
Vortec 6.2L V8 with MAX Trailering Pack	3.73	16,000	-	-	-	10,600	-	10,300	-
Vortec 6.2L V8	3.42	15,000	-	-	-	9,400	-	9,100	-

Notes on Silverado 1500: Trailer tongue weight should be 10% to 15% of total loaded trailer weight. Trailer kingpin weight should be 15% to 25% of total loaded trailer weight. Addition of trailer tongue weight/trailer kingpin weight cannot cause vehicle weights to exceed Rear Gross Axle Weight Rating (RGAWR) or Gross Vehicle Weight Rating (GVWR). These ratings can be found on the certification label located on the driver door or doorframe. Fifth-wheel hitch is available as a dealer-installed accessory on select models. See the Trailering Basics for more trailering information.

## SILVERADO 2500HD AND 3500HD FIFTH-WHEEL/GOOSENECK TRAILER WEIGHT RATINGS<sup>1</sup>

ENGINE	AXLE RATIO	GCWR <sup>2</sup>	REGULAR CAB						
			2500HD LONG BOX 2WD	3500HD LONG BOX 2WD	3500HD LONG BOX 2WD DUALY	2500HD LONG BOX 4x4	3500HD LONG BOX 4x4	3500HD LONG BOX 4x4 DUALY	
Vortec 6.0L V8	4.10	20,500	14,700	14,500	-	14,200	14,400	14,200	13,800
	3.73	16,000	10,200	-	9,600	9,900	9,700	9,300	
Duramax 6.6L Turbo-Diesel V8	3.73	24,500	17,800	-	-	17,500	17,400	-	
	3.73	30,500	-	-	-	-	-	23,100	

ENGINE	AXLE RATIO	GCWR <sup>2</sup>	EXTENDED CAB							
			2500HD STANDARD BOX 2WD	2500HD LONG BOX 2WD	3500HD LONG BOX 2WD	3500HD LONG BOX 2WD DUALY	2500HD STANDARD BOX 4x4	2500HD LONG BOX 4x4	3500HD LONG BOX 4x4	3500HD LONG BOX 4x4 DUALY
Vortec 6.0L V8	4.10	20,500	14,300	14,200	14,000	13,700	14,000	13,900	13,700	13,400
	3.73	16,000	9,800	9,700	9,500	9,200	9,500	9,400	9,200	8,900
Vortec 6.0L V8 Compressed Natural Gas (CNG)	4.10	20,500	-	-	-	-	-	-	-	-
	3.73	16,000	-	-	-	-	-	-	-	-
Duramax 6.6L Turbo-Diesel V8	3.73	24,500	17,500	17,400	17,300	-	16,400	15,700	16,900	-
	3.73	30,500	-	-	-	22,800	-	-	-	22,600

ENGINE	AXLE RATIO	GCWR <sup>2</sup>	CREW CAB									
			2500HD STANDARD BOX 2WD	2500HD LONG BOX 2WD	3500HD STANDARD BOX 2WD	3500HD LONG BOX 2WD	3500HD LONG BOX 2WD DUALY	2500HD STANDARD BOX 4x4	2500HD LONG BOX 4x4	3500HD STANDARD BOX 4x4	3500HD LONG BOX 4x4	3500HD LONG BOX 4x4 DUALY
Vortec 6.0L V8	4.10	20,500	14,200	14,100	14,000	13,900	13,500	13,900	13,800	13,700	13,600	13,200
	3.73	16,000	9,700	9,600	9,500	9,400	9,000	9,400	9,300	9,200	9,100	8,700
Duramax 6.6L Turbo-Diesel V8	3.73	24,500	17,400	16,700	17,200	17,300	-	15,800	14,700	17,000	16,800	-
	3.73	30,500	-	-	-	-	22,800	-	-	-	-	22,500

Notes on Silverado HD: Trailer tongue weight should be 10% to 15% of total loaded trailer weight. Trailer kingpin weight should be 15% to 25% of total loaded trailer weight. Addition of trailer tongue weight/trailer kingpin weight cannot cause vehicle weights to exceed Rear Gross Axle Weight Rating (RGAWR) or Gross Vehicle Weight Rating (GVWR). These ratings can be found on the certification label located on the driver door or doorframe. Fifth-wheel hitch is available as a dealer-installed accessory on select models. See the Trailering Basics for more trailering information.

<sup>1</sup> Maximum trailer weight ratings are calculated assuming a base vehicle, except for any option(s) necessary to achieve the rating, plus driver. The weight of other optional equipment, passengers and cargo will reduce the maximum trailer weight your vehicle can tow. See your Chevy dealer for additional details. <sup>2</sup> Gross Combination Weight Rating.

## TAHOE/SUBURBAN TRAILER WEIGHT RATINGS<sup>1</sup>

ENGINE	AXLE RATIO	GCWR <sup>2</sup>	TAHOE 2WD	TAHOE HYBRID 2WD	SUBURBAN 2WD	SUBURBAN 3/4-TON 2WD	TAHOE 4WD	TAHOE HYBRID 4WD	SUBURBAN 4WD	SUBURBAN 3/4-TON 4WD
Vortec 5.3L V8 with Heavy-Duty Trailing Package	3.42	14,000	8,500	-	8,100	-	8,200	-	8,000	-
Vortec 5.3L V8	3.42	11,500	-	-	5,600	-	5,700	-	-	-
	3.08	11,000	5,500	-	5,100	-	5,200	-	5,000	-
Vortec 6.0L V8	3.73	16,000	-	-	-	9,600	-	-	-	9,400
	3.08	12,000	-	6,200	-	-	-	5,900	-	-

Notes on Tahoe, Suburban and Tahoe Hybrid: Trailer tongue weight should be 10% to 15% of total loaded trailer weight (up to 1,000 lbs.). Addition of trailer tongue weight must not cause vehicle weights to exceed Rear Gross Axle Weight Rating (RGAWR) or Gross Vehicle Weight Rating (GVWR). The Heavy-Duty Trailing Package (K5L) includes auxiliary external transmission fluid cooler and engine oil cooler.

## EXPRESS CARGO VAN TRAILER WEIGHT RATINGS<sup>1</sup>

ENGINE	AXLE RATIO	GCWR <sup>2</sup>	1500	1500 AWD	2500	2500 EXTENDED WHEELBASE	3500	3500 EXTENDED WHEELBASE
Vortec 4.3L V6	3.42	9,500	4,300	-	-	-	-	-
Vortec 4.8L V8	3.42	13,000	-	-	7,400	7,200	7,400	7,100
Vortec 5.3L V8	3.73	12,000	6,700	-	-	-	-	-
	3.42	12,000	6,700	6,500	-	-	-	-
Vortec 6.0L V8	3.42	16,000	-	-	9,900	10,000	10,000	10,000
Vortec 6.0L V8 Compressed Natural Gas (CNG)	3.42	16,000	-	-	9,900 (3-Tank)	-	9,800 (3-Tank)	-
					9,600 (4-Tank)	-	9,500 (4-Tank)	-
Duramax 6.6L Turbo-Diesel V8	3.54	17,000	-	-	10,000	10,000	10,000	-
	3.54	18,500	-	-	-	-	-	10,000

## EXPRESS PASSENGER VAN TRAILER WEIGHT RATINGS<sup>1</sup>

ENGINE	AXLE RATIO	GCWR <sup>2</sup>	1500	1500 AWD	2500	3500	3500 EXTENDED WHEELBASE
Vortec 4.8L V8	3.42	13,000	-	-	6,700	9,700	-
Vortec 5.3L V8	3.73	12,000	6,200	6,000	-	-	-
	3.42	12,000	6,200	6,000	-	-	-
Vortec 6.0L V8	3.42	16,000	-	-	9,800	9,700	9,300
Duramax 6.6L Turbo-Diesel V8	3.54	17,000	-	-	-	10,000	9,700

This chart lists trailer weight ratings for trailering with a weight-distributing hitch. When using a weight-carrying hitch, the maximum trailer weight is 4,000 lbs. with a 400-lb. tongue weight. A weight-distributing hitch and sway control is required for trailer weights greater than 4,000 lbs.

Notes on Express: Trailer tongue weight should be 10% to 15% of total loaded trailer weight (up to 1,000 lbs.). Addition of trailer tongue weight cannot cause vehicle weights to exceed Rear Gross Axle Weight Rating (RGAWR) or Gross Vehicle Weight Rating (GVWR). The standard base cooling system includes all content required to attain maximum trailer weight rating. No optional cooling equipment is available. The Heavy-Duty Trailing Equipment Package (Z82) includes trailer hitch platform and 7-wire trailer wiring harness.

## TRAILERING BASICS

Easy and safe trailering requires a properly equipped vehicle, additional trailering equipment and an appropriate trailer. It also requires loading both the vehicle and trailer properly, using safe driving techniques, meeting regional legal requirements, and following break-in and maintenance schedules. The vehicle owner is responsible for obtaining the proper equipment (hitch ball, hitch type of the proper size and capacity) required to safely tow both the trailer and the load that will be towed. Consult your Owner's Manual or speak to a trailering expert at your Chevy dealership for more information.

## GOOSENECK/FIFTH-WHEEL TRAILERING

Silverado can be equipped with a fifth-wheel or gooseneck trailer hitch. Follow the manufacturer's directions for installation, but note that the hitch must be attached to the truck frame. Do not use the pickup bed for additional support. For proper kingpin tongue load distribution and control of the trailer, the hitch must be mounted so the kingpin load is placed ahead of the rear axle centerline. Fifth-wheel trailer kingpin loads are higher than conventional trailer tongue loads, so pay careful attention to the truck's payload capacity and rear axle weight ratings. Your Chevy dealer can help you calculate the maximum allowable payload and GVWR required for your fifth-wheel trailering application. The weight of any additional equipment and all passengers must be subtracted from the payload weight to determine the maximum kingpin load available.

<sup>1</sup> Maximum trailer weight ratings are calculated assuming a base vehicle, except for any option(s) necessary to achieve the rating, plus driver. The weight of other optional equipment, passengers and cargo will reduce the maximum trailer weight your vehicle can tow. See your Chevy dealer for additional details. <sup>2</sup> Gross Combination Weight Rating.



## WARRANTY INFORMATION

### 100,000-MILE/5-YEAR TRANSFERABLE POWERTRAIN

**LIMITED WARRANTY.** Every 2013 Chevrolet passenger car, light-duty pickup, SUV and crossover comes with a 100,000-mile/5-year (whichever comes first) transferable Powertrain Limited Warranty. Plus, you get 100,000 miles/5 years (whichever comes first) of the 24/7 Roadside Assistance Program and the Courtesy Transportation Program and much more. See dealer for details.

**NEW VEHICLE LIMITED WARRANTY.** GM vehicles registered in the USA are covered for 3 years/36,000 miles (whichever comes first). The complete vehicle is covered, including tires, towing to your nearest Chevrolet dealership and cosmetic corrosion resulting from defects. Repairs will be made to correct any vehicle defect, and most warranty repairs will be made at no charge. In addition, rust-through corrosion will be covered for 6 years/100,000 miles (whichever comes first).

**SILVERADO HYBRID AND TAHOE HYBRID WARRANTY.** In addition to the transferable Chevrolet 36,000-mile/3-year (whichever comes first) New Vehicle Limited Warranty and the 100,000-mile/5-year (whichever comes first) Powertrain Limited Warranty, GM will also warrant certain hybrid components on Silverado Hybrid and Tahoe Hybrid for 100,000 miles/8 years (whichever comes first). No deductibles are associated with the Silverado/Tahoe Hybrid warranty, which is transferable to any subsequent persons assuming ownership of the vehicle during the 100,000-mile/8-year warranty period. See your Chevrolet dealer for details.

### CHEVROLET OWNER CENTER (GMOWNERCENTER.COM/CHEVY).

Register your vehicle with the Chevrolet Owner Center and receive benefits such as online access to your vehicle Owner's Manual, maintenance schedule reminders, service history tracking, warranty and service information, safety information, special offers and privileges, and news and events.

## IMPORTANT INFORMATION

**ENGINES.** Chevrolet products are equipped with engines produced by GM Powertrain or other suppliers to GM worldwide. The engines in Chevrolet products may also be used in other GM makes and models.

**ASSEMBLY.** Chevrolet vehicles and their components are assembled or produced by different operating units of General Motors, its subsidiaries or suppliers to GM worldwide. We sometimes find it necessary to produce Chevrolet vehicles with different or differently sourced components than originally scheduled. Since some options may be unavailable when your vehicle is assembled, we suggest you verify that your vehicle includes the equipment you ordered and that, if there were changes, they are acceptable to you.

**AN IMPORTANT NOTE ABOUT ALTERATIONS AND WARRANTIES.** Installations or alterations to the original GM-equipped vehicle (or chassis) are not covered by the General Motors New Vehicle Limited Warranty. The special body company, assembler, equipment installer or upfitter is solely responsible for warranties on the body or equipment and any alterations (or any effect of the alterations) to any of the parts, components, systems or assemblies installed by GM. General Motors is not responsible for the safety or quality of design features, materials or workmanship of any alterations by such suppliers.

**ONSTAR.** OnStar services require vehicle electrical system (including battery), wireless service and GPS satellite signals to be available and operating for features to function properly. OnStar acts as a link to existing emergency service providers. Subscription Service Agreement required. Call 1-888-4ONSTAR (1-888-466-7827) or visit onstar.com for OnStar Terms and Conditions, Privacy Statement, and details and system limitations.

**A NOTE ABOUT CHILD SAFETY.** Always use safety belts and the correct restraint for your child's age and size. Even in vehicles equipped with the Passenger Sensing System, children are safer when properly secured in a rear seat in the appropriate infant, child or booster seat. Never place a rear-facing infant restraint in the front seat of any vehicle equipped with a passenger air bag. See the Owner's Manual and child safety seat instructions for more information.

**IMPORTANT WORDS ABOUT THIS CATALOG.** We have tried to make this catalog comprehensive and factual. We reserve the right, however, to make changes at any time, without notice, in prices, colors, materials, equipment, specifications, models and availability. Specifications, dimensions, measurements, ratings and other numbers in this catalog and other printed materials provided at the dealership or affixed to vehicles are approximations based on design and engineering drawings, prototypes and laboratory tests. Your vehicle may differ due to variations in manufacture and equipment. Since some information may have been updated since the time of printing, please check with your Chevrolet dealer for complete details. Chevrolet reserves the right to lengthen or shorten the model year for any product for any reason or to start and end model years at different times. Certain vehicle features may lose their usefulness over time due to obsolescence from technological changes. Unless otherwise noted, all claims based on GM segmentation and latest available competitive information. Excludes other GM vehicles.

**SPARE TIRE INFORMATION.** There is no standard jack or spare tire in the 2013 Tahoe Hybrid and Commercial Cutaway models. Your vehicle has a tire sealant and compressor kit that uses a liquid tire sealant to temporarily seal up to a one-quarter-inch puncture in the tread area of the tire. After using the tire inflator kit, it is recommended that you take the tire to an authorized retailer for inspection and repair as soon as possible, but at least within 100 miles of driving. The tire sealant cannot seal and inflate sidewall damage, punctures larger than one-quarter inch, or a tire that has unseated from the wheel. The sealant can only be used on one tire and for one time before its expiration date.

**TRAILERING AND OFF-ROAD DRIVING INFORMATION.** Please go to chevy.com and carefully review an Owner's Manual for important safety information about trailering or off-road driving in your vehicle.

## WE'VE GOT YOUR BACK

At Chevrolet, giving you a completely satisfying ownership experience is our top priority. That's why if you ever need assistance, feel free to contact us at these websites or phone numbers.

**CHEVY.COM.** Offers shopping tools such as Build and Price, Find a Vehicle, Request Info, Email Sign-Up, Compare Vehicles, Financial Tools ... and much more.

**GMUPFITTER.COM.** Offers nearly everything you need to begin upfitting your Chevy Commercial vehicle, including handling 2-D and 3-D math data; taking hotline questions; and supplying Body Builders Manuals (from 1999 to present), Technical Bulletins and Best Practices Guidelines.

**24-HOUR ROADSIDE ASSISTANCE PROGRAM (1-800-CHEV-USA).** The Chevrolet Roadside Assistance Program provides you with the following services for 100,000 miles or 5 years (whichever comes first): Emergency Towing (to closest Chevrolet dealer from a legal roadway), Lockout Service (keys locked inside vehicle), Flat Tire Changes (spare installed), Fuel Delivery (\$5 worth of fuel delivered on the road) and Jump Starts (at home or on the road). For specific terms and conditions, please contact your Chevrolet Roadside Assistance advisor at 1-800-243-8872. Some services may incur costs.

**COURTESY TRANSPORTATION PROGRAM.** Ask your Chevrolet dealer for Courtesy Transportation if you leave your vehicle for extended repairs under the New Vehicle Limited Warranty or Powertrain Limited Warranty. Ask if you qualify for expense reimbursement and/or vehicle rental. Services vary by dealer. Does not apply to Commercial Cutaway Vans.

**CHEVROLET CUSTOMER ASSISTANCE CENTER (1-800-222-1020).** Talk directly to customer relationship managers who can handle any inquiries related to vehicle operation, warranty coverages, or product or service concerns you may have. Please refer to your Owner's Manual for Customer Assistance information.

**CHEVY.COM/SAFETY.** Chevrolet is committed to keeping you and your family safe – from the start of your journey to your destination. That's why every Chevrolet is designed with a comprehensive list of safety and security features to help give you peace of mind.

**MARKETING AND INCENTIVES (CHEVY.COM/SPECIALOFFERS).** Call 1-800-950-CHEV (1-800-950-2438) or visit chevy.com/specialoffers for new product, current incentive and marketing program information.

**GMCARDMEMBERSERVICES.COM.** Did you know about the family of reward credit cards that can help you get a great deal on a new GM car, light-duty pickup, SUV or crossover? With a GM reward card, you accrue earnings on every credit card purchase to use toward the purchase or lease of an eligible new GM vehicle. With three cards to choose from, you're sure to find one that suits you best.

GM, the GM Logo, Chevrolet, the Chevrolet Logo and the slogans, emblems, vehicle model names, vehicle body designs and other marks appearing in this catalog are the trademarks and/or service marks of General Motors, its subsidiaries, affiliates or licensors. Allison is a registered trademark of Allison Transmission, Inc. ©2012 OnStar. All rights reserved. ©2012 General Motors. All rights reserved. July 2012



**BUSINESS CHOICE.** You can get the commercial vehicles you depend on every day, equipped with the upfits you need to get the job done. If you are a qualified commercial customer<sup>1</sup> and purchase or lease an eligible Chevy van or truck,

you have a choice of valuable upfit equipment or card options to meet your business needs. Visit [gmbusinesschoice.com](http://gmbusinesschoice.com) for details.

Visit [chevy.com](http://chevy.com) for special offers and to find a Chevy dealer.



[chevy.com](http://chevy.com)

<sup>1</sup> To qualify for the GM Business Choice Program, your vehicle must be used in the day-to-day operations of your business and not solely for transportation purposes, and you must provide proof of your business. See your dealer for complete program details.