



MASERATI

GHIBLI





MASERATI



TARGA FLORIO: PROVING GROUNDS FOR THOSE WITH SOMETHING TO PROVE.

In the early 1900s, sleepy villages and rural, rutted trails in the mountains of Sicily were suddenly overrun with roaring, speeding cars, all vying to win the title of an automobile race called Targa Florio. Dreamed up by Vincenzo Florio, a wealthy Italian businessman, this treacherous, winding endurance course was as popular with race fans as it was with local villagers, who walked for miles to catch a glimpse of the glorious machines and their drivers. Maserati has always had a huge presence at Targa Florio. Maserati drivers and their cars were famous: from Alfieri Maserati in the Tipo 26 to Maria Teresa de Filippis in her Maserati A6GCS. For decades, the race was among the most important in the world until it was deemed too dangerous to run. Now, the Rally Targa Florio is a non-competitive event for vintage automobiles, and it is no coincidence that historic cars bearing the Trident inspire fans even today.





MASERATI A6GCS/53 AT THE 1955 TARGA FLORIO,
DRIVEN BY MARIA TERESA DE FILIPPIS AND LUIGI BELLUCCI.



MASERATI GHIBLI ON THE ROUTE OF THE TARGA FLORIO.
THE TIMES HAVE CHANGED, THE ROUTE AND INSPIRATION REMAIN.





*The Ghibli shown in Rosso Energia with 20-inch Urano machine-polished wheels.
In the background, the original Maserati 3500 GT Touring.*





Maserati Tipo 63



GHIBLI: THE LATEST FRUIT OF ITALIAN INNOVATION.

While the Targa Florio has been transformed into a showcase event for vintage and classic cars, its lessons of sheer determination, resilience and the rewards of hard work are a reflection of its Sicilian hosts. In just the past two decades, entrepreneurs have turned Sicily into Italy's most prolific wine-producing region. It's the same kind of ingenuity and pursuit of quality

that has long established Maserati as one of the world's finest automakers. So, while there is great pride in the historical accomplishments of the brand, the focus is always forward. The Maserati Ghibli is the proud product of both the collective knowledge and the latest, most inventive thinking of this legendary marque.





Maserati

Ghibli

Ghibli



THE BEAUTY THAT LIES WITHIN IS,
AT ONCE, SIMPLE AND COMPLEX.

For aficionados of both wine and motorcars, quality and character are things that are ascertained through sight, smell, touch—not by simply relying on a name or a label. Opening the door of a Ghibli is much like appreciating and evaluating a bottle of fine wine ... its opulent materials and handcrafted quality speak to all the senses. Proof that what is on the inside counts most of all.







EXTERIOR DESIGN

SCULPTED BY MASTERS INSPIRED BY NATURE.

The Maserati Ghibli is a masterpiece of design, emphasizing both elegance and sportiness. What makes the Ghibli's sleek and flowing lines so dramatic are the front and rear wheel arches, which merge into a single central form to create a breathtakingly beautiful silhouette, its gleaming metal making a solid statement, much like a wind-carved stone peak. The front of the Ghibli is dominated by the distinctive Maserati grille, with concave vertical fillets inspired by the current GranTurismo and

the A6GCS Berlinetta, a classic Maserati of the past. The grille's traditional oval shape narrows at the top, where it meets the aggressive headlights that make skillful use of LED daytime running lights to emphasize the car's powerful persona. Continuing along the side, two curved lines merge together before giving way to the muscular rear end. Here, the tapered design of the rear deck is the natural continuation of the cabin, while the two LED taillights provide continuity with the wheel arches. The triangular C-pillar and the frameless door windows give the Ghibli the appearance of a sleek and agile sports coupé, even though its length and wheelbase are among the longest in its class.

OUR HIGH STANDARDS
CAN BE DISTILLED TO ONE
VITAL INGREDIENT: PASSION.

The process and precision that go into every Maserati cannot be overstated. State-of-the-art engineering is apparent throughout the car: from the chassis to the transmission, through to the suspension and brakes, every component plays a part in delivering levels of comfort and performance that only Maserati drivers can enjoy. This passion for quality enhances reliability, for which the Maserati Ghibli is renowned. As part of the car's exhaustive development program, Ghibli prototypes were driven in the most extreme weather conditions across South Africa, Morocco, Sweden and New Zealand. Such thorough action is key to continued success. Perhaps it is no coincidence that so many of our drivers share this trait themselves.





ARGENTORIO

104

1906 - 1956

CINQUANTE MASERO









*Ghibli shown with 21-inch Titanio forged wheels.
Polished calipers not available in the North American market.*



Maserati

Ghibli

Q4







Ghibli shown in Nero





THE CRAFT COMES FROM THE HANDS. THE KNOWLEDGE THAT DELIVERS IT IS A GIFT.

The Maserati Ghibli's unique personality is also expressed in its luxurious cabin. The seats are upholstered in soft leather, which can also be specified for the dashboard and doors in dual color combinations for either a sporty or more elegant interior look. Exquisite leather stitching reflects the very finest traditions of Italian craftsmanship.



European model Ghibli shown with Nero leather interior.



MASERATI
TOUCH CONTROL

GranTurismo

AC

OFF

AUTO

+

-

+

AUTO

OFF

+ M

R

N

D

ON BOARD

DELIGHT IN DETAILS FOCUSED ON PERFECTION.

The smooth lines of the dashboard surround the Ghibli's occupants with an atmosphere of opulence: two side panels converge in the center, drawing in the top section that features the traditional Maserati clock and aluminum detailing. The precision of the Trident logo that is embossed on the headrests is a clear indication of the immense care given to the seats. Their wraparound form enhances the interior's sporty look while still delivering the highest levels of comfort. The soft

leather used for the upholstery has a natural texture that makes it particularly pleasant to the touch. The electric front seat adjustment system on the Ghibli makes it easy to achieve the perfect driving position. The Maserati Ghibli is equipped with the very latest information and entertainment system that makes life on board either relaxing or invigorating, depending on your mood.



The Maserati Ghibli can be equipped with options designed to make driving even more convenient and rewarding. These include the exterior electrochromic rearview mirrors that darken progressively as light intensity increases and a rear windscreen sunshade to enhance privacy and screen occupants from sunlight.

For greater thermal insulation and quieter journeys, the Ghibli can be specified with double-laminated acoustic glass windows (a standard feature of the front windscreen).

CLIMATE CONTROL SYSTEM

The dual-zone climate control automatically adjusts the intensity of the ventilation in relation to the outdoor temperature, and allows those on board to select their own individual temperature settings.

With 13 ventilation outlets, the system is able to cool or heat the car extremely rapidly and maintains the temperature by means of the Maserati touch-control display or the control panel beneath it. The system is fitted with an anti-misting sensor that is automatically programmed to reduce the humidity content of the air as soon as the windows start to mist up.

KEYLESS GO / KEYLESS ENTRY

In the world of Maserati, small details are everything—right down to the design of the aluminum key, which reflects the Ghibli's style and incorporates "Keyless Go" technology. The standard keyless entry function enables the driver to open the doors or trunk without ever touching the key. Once inside the car, the driver needs only to press the ignition button to start the engine.

STORAGE COMPARTMENTS

The interior of the Maserati Ghibli features numerous storage compartments. Along with the spacious, illuminated, climate-controlled glove box, there are two concealed cupholders in the central tunnel and a handy cubbyhole with auxiliary and USB inputs for the connection of remote devices. Underneath the front armrests, there is another illuminated, climate-controlled compartment, with two more cupholders and a 12V power outlet. In the rear, the bench seat is divided by a fold-down central armrest that can be equipped with a 12V power source and a USB port.

TRUNK

The trunk of the Maserati Ghibli is designed to provide maximum space and versatility. Its luggage capacity of almost 18 cubic feet accommodates large suitcases with ease, and it is equipped with lighting, a handy 12V power outlet and special chromed rings for the connection of luggage nets. The rear bench seatback can be folded down, asymmetrically, to take large items of luggage.



Bowers & Wilkins

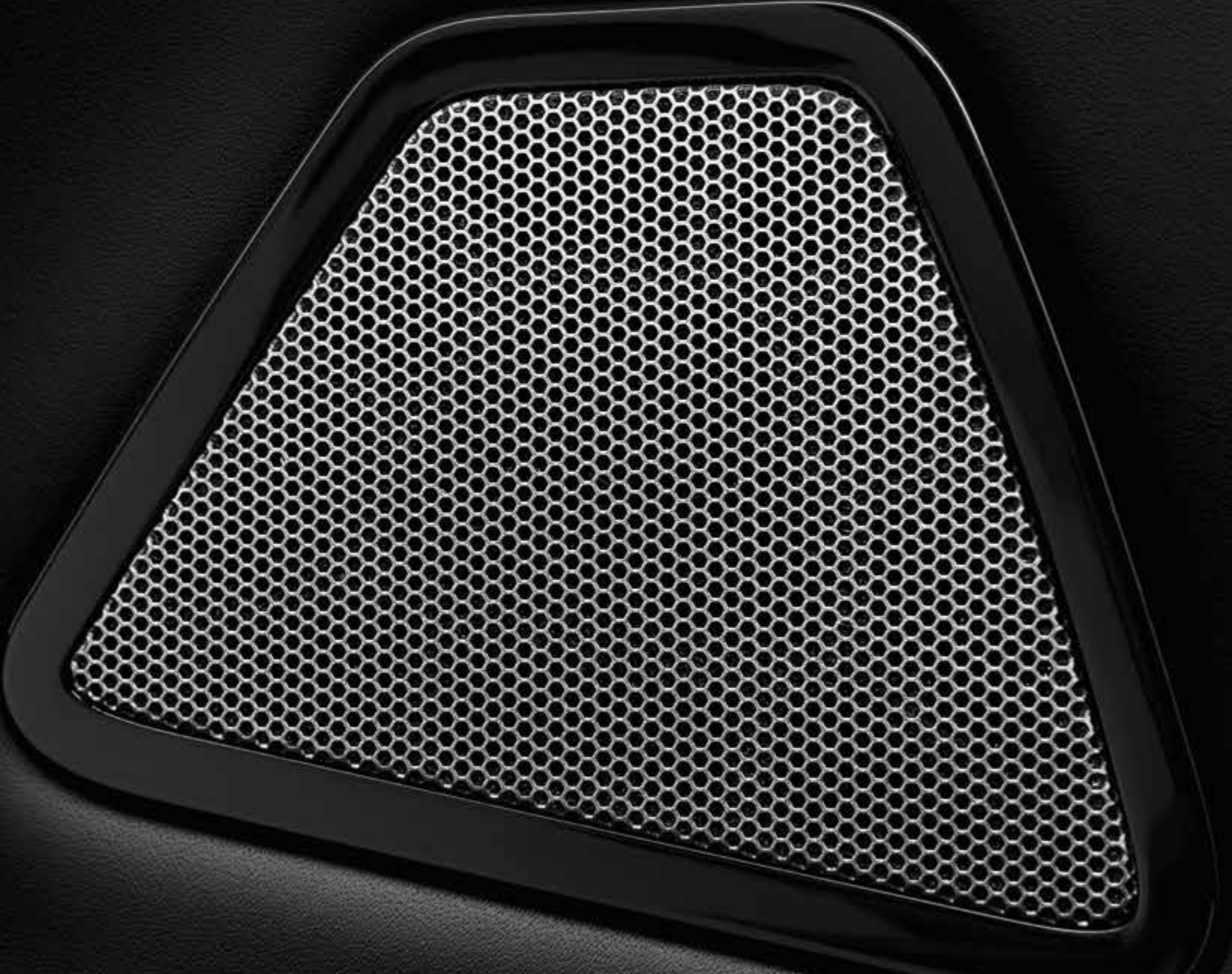

BOWERS & WILKINS

EACH NOTE IS DELIVERED THE WAY THE MUSICIAN INTENDED.

Uncompromising automotive excellence is a Maserati promise that extends to every aspect of the driving experience, including providing immersive, concert-hall acoustics in the Maserati Ghibli. Its new-generation premium surround system, created in association with high-end sound specialists Bowers & Wilkins, offers a sound experience that is just as thrilling as Ghibli's distinctive, throaty exhaust note. This optional hi-fi system reproduces every subtle note to perfection, with

unparalleled dynamic purity. The system is architecturally designed and enhanced with digital features to ensure a rich sound experience in every position of the interior, so everyone in the car reaps the audio benefits. It is stunning sound for an astounding car.

INNOVATIVE MATERIALS

The speakers installed in the Ghibli benefit from the very latest technology and materials, such as Kevlar® and aluminum. These provide the ideal combination of lightness and rigidity, and extend the resulting sound to the very limits of human hearing. For the very best bass sounds, the speaker cones are made of Rohacell®, a material normally used in the aeronautics industry.



INTEGRATED ACOUSTICS

The Bowers & Wilkins Premium Surround Sound System includes a 16-channel, 1,280-watt amplifier that blends perfectly into the car's interior design, thanks to painstaking work on the layout of the sound sources. Fifteen speakers are located in the dashboard, doors and rear shelf to deliver the ultimate in acoustics without compromising the elegance of the cabin.

CONFIGURED TO PERFECTION

The tuning of a sound system is a sophisticated art, requiring countless hours of listening by the most highly trained ears. The Ghibli's Premium Surround Sound System has been configured by the engineers responsible for the Bowers & Wilkins 800 Series Diamond speakers—the ones used in London's famous Abbey Road Studios.

SURROUNDED BY SOUND

The HARMAN QuantumLogic™ Surround Sound processing system recognizes and isolates the various elements in an audio track—for instance, the musical instruments, the voices and the internal reverb. These are separated and processed to provide crystal-clear sounds with the highest possible definition.



THE MASERATI GHIBLI RANGE

UNDER EVERY HOOD, A RICH RACING HERITAGE.

During the development of the Ghibli, one of the main aims of its designers and engineers was to capture the dynamic excitement of Maserati's competition past. Under the hood of each Ghibli is an engine specifically designed to deliver the power needed to reach that goal ... and to go beyond. The Ghibli is powered by a versatile 345 HP, 3.0-liter, twin-turbocharged V6 engine. The 404 HP V6 engine of the Ghibli S Q4 delivers thrills with every mile and through every turn. Its driver connects to the Maserati racing heritage simply by stepping on the accelerator. Driving has never been more rewarding—even for the most demanding of enthusiasts.



THE VERSATILE GHIBLI S Q4

SPLIT-SECOND RESPONSE TIMES WHEN THEY ARE NEEDED MOST.

The Ghibli S Q4 is equipped with an innovative on-demand intelligent all-wheel-drive system capable of combining exhilarating driving pleasure with utmost safety on all road surfaces. Normally, it is up to the rear-wheel-drive system to transfer the Ghibli S Q4's 404 HP to the terrain, but if the road surface becomes slippery or the wheels lose grip, the system instantaneously (in just 150 milliseconds) transfers the necessary drive force to the front wheels. In terms of handling, the

adoption of front double-wishbone and rear five-arm multilink suspension combines comfort with sporty handling, while the 8-speed ZF automatic transmission is controlled by auto-adaptive software able to switch from the smooth gearshifts of Auto Normal mode to the Manual Sport mode, which gives the driver full control over all gear changes. The Ghibli S Q4 delivers impressive acceleration, going from zero to 60 mph in just 4.7 seconds and has a top speed of 176 mph.





THE GHIBLI S Q4 FEATURES MASERATI INTELLIGENT ALL-WHEEL DRIVE TO SUPPLY TRACTION SEAMLESSLY ON DEMAND.



THE UNMISTAKABLE GHIBLI

POWER AND EFFICIENCY.

The Maserati Ghibli's twin-turbocharged V6 engine has been designed to achieve the lowest possible fuel consumption and CO₂ emissions, while at the same time delivering extremely high performance. The numbers are a clear indication of Ghibli's sporting prowess: 345 HP and a top speed of 163 mph. From a standstill, the Maserati Ghibli accelerates to 60 mph in 5.5 seconds. The Sport button on the transmission tunnel activates the overboost function, allowing the engine's torque to soar. This six-cylinder engine features modifications that cut fuel consumption, while sacrificing little in the way the car responds to the accelerator.

The twin-turbo system has two intercoolers, with an aluminum alloy crankcase and cylinder heads, keeping the weight of the car low and ensuring the best possible responsiveness and handling. A compact, lightweight exhaust system includes an air-valve system capable of adding extra drama to the Ghibli's stirring exhaust note. In I.C.E. and Normal modes, the valves remain closed, keeping the engine noise discreet and understated. However, when the Sport button is pressed, the bypass valves open up to release a formidable roar.



TECHNOLOGY AND SAFETY

THE TRANSMISSION IS NOT A PIECE OF ART: IT IS A GALLERY.

The Maserati Ghibli benefits from the sophistication and refinement of the latest-generation eight-speed ZF automatic transmission. Lightweight, precise and easily capable of coping with the car's high-performance engines, it uses auto-adaptive software to recognize the driving style and road conditions, and then alters the gear-changing mode accordingly. The last two gears, seventh and eighth, have been specially calibrated to reduce fuel consumption and increase comfort on long, high-speed journeys.

On the Maserati Ghibli, the front-mounted gearbox transmits the drive to the rear wheels by means of a dual-section, articulated driveshaft. This is coupled to a limited-slip mechanical differential, with an asymmetric locking function that allows locking of 35 percent during traction and 45 percent during release. There are five operating modes, selected using the buttons by the gear lever: Auto Normal, Auto Sport, Manual Normal, Manual Sport and the new I.C.E. (Increased Control & Efficiency).





AUTO NORMAL MODE

This preset mode provides smooth gearshifts at low revs to maximize ride comfort and minimize fuel consumption. When a more sporty style of driving is recognized, upshifts automatically take place at higher engine speeds.

AUTO SPORT MODE

The gearshifts are faster and occur at higher revs for a much more sporty driving style.



MANUAL NORMAL MODE

The driver can change gear using the optional paddles behind the steering wheel or the lever on the central tunnel. The system automatically shifts up a gear as the maximum engine speed approaches, and shifts down in the same way.

MANUAL SPORT MODE

The driver takes full control of the transmission: gearshifts are quicker and sharper, and the engine can be pushed right to the limit without the system intervening. The only automatic feature is downshifting if the revs drop too low.



I.C.E. (INCREASED CONTROL & EFFICIENCY) MODE

Developed not only for use in icy conditions, this mode is intended to ensure an even quieter, smoother ride, and also a reduction in fuel consumption. In I.C.E. mode, gearshifts take place automatically and are almost unnoticeable, for unrivaled ride comfort.



The Maserati Ghibli's stunning design is made possible thanks to a brand new frame that is made from aluminum alloy to achieve strict weight and strength targets. For a car with the longest wheelbase in its class, the Ghibli's roadholding and handling are outstanding. Meanwhile, its occupants enjoy the highest levels of safety.

A combination of aluminum and steel ensures that the car's weight distribution is ideally balanced, while special stiffening crossmembers deliver exceptional torsional rigidity.

In keeping with Maserati traditions, the Ghibli features a highly sophisticated suspension set-up. The aluminum arms of the double-wishbone front suspension are higher up for more precise handling, while the five-arm multilink system at the rear provides the perfect blend of comfort and agility. Particular attention has been focused on weight reduction: a large number of suspension components are made of lightweight aluminum, and the front stabilizer bar is hollow.

The Ghibli can also be equipped with the optional Skyhook suspension, with new shock absorbers featuring continuous-damping variation. The basic setting gives priority to ride comfort, but if more dynamic handling is required, the driver presses the Suspension button on the central tunnel and the shock absorbers immediately stiffen, significantly reducing load transfer during fast cornering.

The Ghibli S Q4 is equipped with dual-cast discs that combine the strength of cast-iron with the lightness of aluminum to help reduce the unsprung mass. Braking power is provided by efficient monobloc calipers, with six pistons at the front and four at the rear acting on ventilated, cross-drilled discs: 360 mm x 32 mm (front) and 350 mm x 28 mm (rear).



These brakes not only deliver extremely short stopping distances, but are highly resistant to brake fade when the car is driven hard and fast over long distances. The servo-assisted hydraulic steering system ensures that the driver receives the very best feedback from the steering wheel, with no annoying feel of artificial assistance when cornering at high speeds. Specifically designed to make driving as enjoyable as possible, the Ghibli's steering system is light and responsive, even when parking. This precision is further enhanced by a new aluminum steering box, specifically developed to suit the front suspension layout.

MASERATI STABILITY PROGRAM (MSP)

The Maserati Stability Program (MSP) is an advanced electronic stability control system that reduces torque from the engine and activates the brakes if the vehicle begins to deviate from its normal trajectory or if a skid is detected. All this happens in just a few milliseconds.

The system combines a number of devices including Anti-Slip Regulation (ASR), which reduces wheelspin and improves traction, and Motor Spin Regulation (MSR), which prevents wheels from locking up when changing down suddenly. Antilock Braking System (ABS) and Electronic Brake-force Distribution (EBD) monitor the car's braking, stopping the wheels from locking and distributing the braking force between the front and rear axles. A Brake Assistance System (BAS) then recognizes emergency stops and boosts the pressure in the hydraulic circuit for the ultimate in stopping power.

TIRE PRESSURE MONITORING SYSTEM (TPMS)

The Tire Pressure Monitoring System (TPMS) is a device that continuously monitors tire pressures by means of sensors fitted inside the wheel rims. The tire pressure is shown on the display at the center of the dashboard, and a beeper and warning light alert the driver if this drops below the optimal level or in the event of a puncture.

CRUISE CONTROL

The Maserati Ghibli comes equipped with Cruise Control, operated from the steering wheel. The set speed is shown on the display at the middle of the instrument panel and is maintained even when the road climbs or descends—the system makes the car accelerate or decelerate accordingly.

PARKING SENSORS AND REVERSING CAMERA

To assist with maneuvering in tight spaces, the Maserati Ghibli comes equipped with parking sensors housed in the front and rear bumpers. Beeping noises increase in frequency as the obstacle approaches, while the TFT display at the center of the instrument panel shows the car surrounded by symbols which light up in green, yellow or red, depending upon the remaining distance. In addition, there is an optional rearview camera, fitted close to the trunk lock that shows a view of what is behind the car on the Maserati Touch Control display.

ADAPTIVE FRONT LIGHTING SYSTEM (AFS)

The outstanding lighting provided by the bi-Xenon headlights is further enhanced by the AFS, which automatically adjusts the width and depth of the beam. This is made possible by a camera mounted in the rearview mirror and sensors that monitor several different parameters, including the lights of other road users, the car's speed and the way it is being driven. If the road ahead is empty, the beam expands to its maximum width and depth for the best visibility, with no need to switch manually to full-beam mode.

The advantages offered by the AFS system are perceived especially in case of bad weather and for motorway or town driving. In these conditions the system adjusts automatically to increase visibility and driving safety.

ELECTRIC PARKING BRAKE (EPB)

The Ghibli is equipped with an EPB that is engaged via a control on the gear lever surround instead of a conventional mechanical lever.

If necessary, it can be used when the car is moving: the system communicates with the MSP and acts on all four wheels to obtain an immediate braking action (a deceleration of 0.5 g), without any loss of stability, until the control is released.

HILL HOLDER

To help the driver when starting off on an uphill slope, the Ghibli comes with the Hill Holder system. On a gradient, this device keeps the car braked for a short time, thus allowing the driver's foot to move from the brake to the accelerator pedal without the car rolling backwards.



MASERATI
10

RES+
CANC
SET-
DRIP

4
5
6
7
8
9
10

0 20 40 60 80 100 120 140 160 180 200 220 240 260 280 300 320 340 360 380 400 420 440 460 480 500 520 540 560 580 600 620 640 660 680 700 720 740 760 780 800 820 840 860 880 900 920 940 960 980 1000

0 1 2 3 4 5



Maserati made passive safety a top priority when designing the Ghibli. To provide the best possible protection for its occupants and help it achieve its aim of a 5-Star Safety Rating by EURO NCAP and US NCAP, it features the latest-generation airbag system and a special front-end crumple structure.

AIRBAGS

The Maserati Ghibli comes equipped with seven airbags. Two front airbags, both dual-stage, shield the driver and front passenger in the event of collision, while their torsos and hips are further protected by two side airbags located in the front seats. There are also two window airbags fitted in the roof next to the central pillar that cushion the heads of the front and rear passengers if the car is struck from the side. Finally, a seventh airbag protects the driver's legs.

SEATBELT PRETENSIONERS AND ACTIVE HEADRESTS

The front seatbelts are fitted with electronically controlled pyrotechnic pretensioners and the latest-generation load limiters. The system communicates with a sensor to determine the seriousness of a collision, and then activates with precisely the right amount of force to reel in the optimum length of belt. If the car is hit from behind, the active headrests of the two front seats automatically move in closer to the occupants' heads to reduce the risk of whiplash injury. Both side seats at the rear are fitted with ISOFIX fasteners for child seats, ensuring that the youngest passengers are properly protected as well.



DIMENSIONS GHIBLI

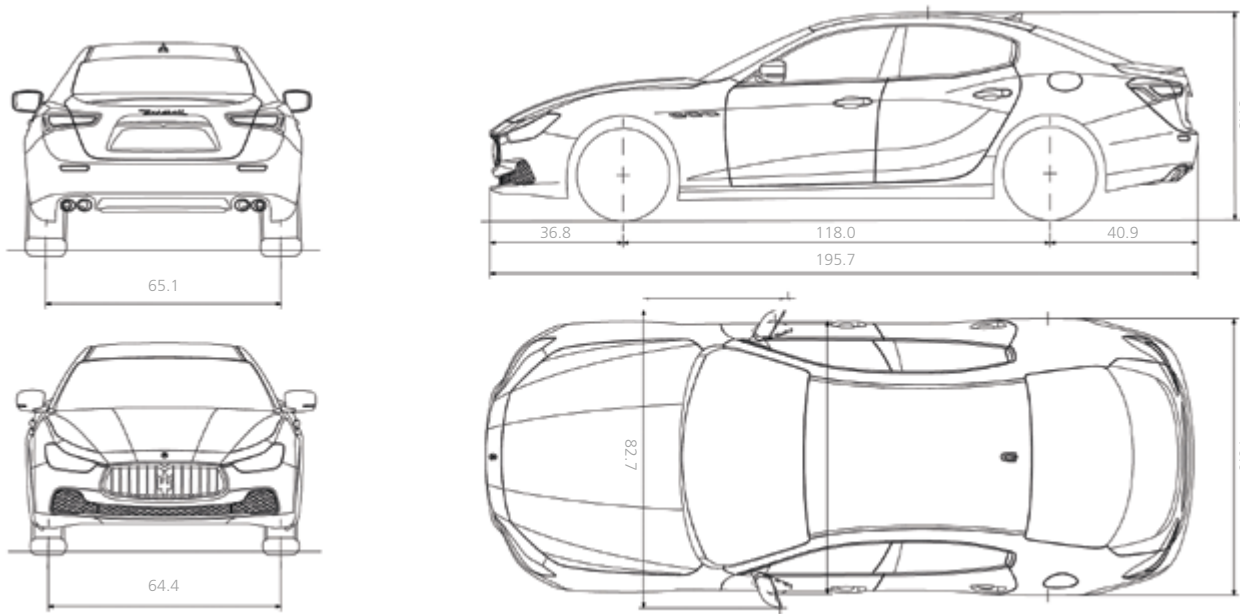

	GHIBLI	GHIBLI S Q4
Fuel consumption—urban cycle	20.3 mpg	17.8 mpg
Fuel consumption—extra urban cycle	40.4 mpg	37.2 mpg
Fuel consumption—combined cycle	29.4 mpg	26.9 mpg
CO ₂ emissions—urban cycle	520 g/mi	592 g/mi
CO ₂ emissions—extra urban cycle	265 g/mi	283 g/mi
CO ₂ emissions—combined cycle	359 g/mi	396 g/mi

DIMENSIONS AND WEIGHTS

	GHIBLI	GHIBLI S Q4
Length	195.7 in (4971 mm)	195.7 in (4971 mm)
Width (with side mirrors)	82.7 in (2100 mm)	82.7 in (2100 mm)
Width (without side mirrors)	76.6 in (1945 mm)	76.6 in (1945 mm)
Height	57.5 in (1461 mm)	57.5 in (1461 mm)
Wheelbase	118.0 in (2998 mm)	118.0 in (2998 mm)
Front track	64.4 in (1635 mm)	64.4 in (1635 mm)
Rear track	65.1 in (1652 mm)	65.1 in (1652 mm)
Front overhang	36.8 in (935 mm)	36.8 in (935 mm)
Rear overhang	40.9 in (1038 mm)	40.9 in (1038 mm)
Turning circle	38.4 ft (11.7 m)	38.4 ft (11.7 m)
Trunk capacity	17.7 cu ft (500 L)	17.7 cu ft (500 L)
Fuel tank capacity	21.1 gal (80 L)	21.1 gal (80 L)
Curb weight	3,990 lbs (1810 kg)	4,122 lbs (1870 kg)

ENGINE

Number of cylinders and layout	V6 60°	V6 60°
Displacement	182 cu in (2979 cm ³)	182 cu in (2979 cm ³)
Transmission	8-speed automatic	8-speed automatic
Compression ratio	9.7:1	9.7:1
Maximum power output	345 HP (330 CV / 243 kW)	404 HP (410 CV / 302 kW)
Engine speed at maximum power output	5,000 rpm	5,500 rpm
Peak torque	369 ft lb (500 Nm)	405 ft lb (550 Nm)
Engine speed at peak torque	4,500 rpm	5,000 rpm
Overboost torque	369 ft lb (500 Nm)	406 ft lb (550 Nm)
Engine speed at overboost torque	1,750 – 4,500 rpm	1,750 – 5,000 rpm

PERFORMANCE

Maximum speed	163 mph (263 km/h)	176 mph (284 km/h)
Acceleration from 0-60 mph (0-100 km/h)	5.5 sec (5.5 sec)	4.7 sec (4.7 sec)
Stopping distance from 60 mph (100 to 0 km/h)	118 ft (36 m)	114 ft (35 m)



WORLD OF MASERATI

THE MASERATI LEGEND: NEVER RE-CREATED. RARELY CAUGHT.

Maserati was founded as a racing car constructor, and its deepest roots are in the world of competition. After the impressive records set by the MC12, the racing spirit lives on today in the Maserati Trofeo MC, the international single-marque championship for drivers who wish to compete in the GT class.

TROFEO MC WORLD SERIES: STYLISH TRACK EXCITEMENT

The Maserati Trofeo MC is one of the most successful international GT racing series, with events in Europe, the United States, Japan and China. For more information, visit maseraticorse.com or send an email to TrofeoMaserati@maserati.com

MASTER MASERATI DRIVING COURSES

It is perhaps the ultimate driving experience: taking to the racetrack in a race-tuned Maserati. A Master Maserati Driving Course places you behind the wheel of all Maserati range models so that you can learn about performance driving and other techniques.

WARM-UP 2015

The Maserati Master Warm Up offers Maserati enthusiasts training in the techniques of race-circuit driving in high-performance cars, with the support of a qualified, expert staff. It is an opportunity to enter the Maserati world as a privileged guest, starting with a morning visit to the Factory where the brand's unmistakable cars are built and moving on to the Varano de' Melegari circuit, home of the Master Maserati courses. It is a whole afternoon of dynamic activities, including several on-circuit driving sessions combined with a car-handling exercise that tests students' driving abilities, which can then be perfected in subsequent course levels.



MASTER GT 1 DAY

The one-day Master GT course is designed to improve personal driving techniques at the wheel of different Maseratis. This intensive training program comprises a number of exciting and dynamic sessions in high-performance cars, and is run by a highly trained specialist staff whose aim is to improve every participant's personal driving skills in an environment that is enjoyable and challenging for all.

MASTER GT 2 DAYS

An intensive two-day course that focuses on advanced GT driving techniques and safe yet sporty driving. In a sequence of sessions on the circuit, the driver is taught how to control the car in different simulated road conditions such as quick direction changes, controlled skids and braking techniques. The ultimate aim is to use the lessons learned to maximize the enjoyment of driving a high-performance Maserati.

MASTER HIGH PERFORMANCE

The Master High Performance program includes advanced high-speed driving and more technically complex exercises that build upon the fundamental skills acquired in the earlier Master GT courses. The teaching and structure of this course are adapted



to the individual needs of the participants, who can improve their driving proficiency through the analysis of Formula 1-type telemetry data.

MASTER ITALIAN LIFESTYLE EXPERIENCE

This exclusive, five-star event allows Maserati enthusiasts and their companions to experience the very best that Italy has to offer. Along with a series of Maserati racetrack sessions for the driver, both participants enjoy a program of first-class activities and excursions in two cities steeped in history and culture: Florence and Parma.

MASTER MASERATI INCENTIVE

The incentive courses last either a half day or a whole day, and include a series of highly stimulating activities. Aside from the thrilling driving sessions on the track, there are practice exercises and competitions that foster team spirit—hence they provide the perfect context for corporate incentive and team-building events.

TO REGISTER, CONTACT MASTER MASERATI:

Telephone: +39 0525 551138 Fax: +39 0525 551140

Email: info@mastertg.it

For more information, visit maserati.us/mastermaserati

FACTORY TOUR*

See where and how the Maserati myth is born. Maserati offers you the opportunity of finding out about its secrets from the inside, through a guided tour of the Modena production plant. Discover how the cars are made, learn their secrets, fully understand their engineering and really feel part of the Maserati family.

MASERATI EXPERIENCE

For those wishing to combine their factory visit with a little more insight into the company's home city of Modena, Maserati has the perfect solution. Lasting one or more days, the Maserati Experience enables you to get to know the world of Maserati firsthand via a guided tour that allows you to discover Modena, its culture, its history and its fine food. For more information, please contact us by writing to maseratiexperience@maserati.com

*Tours are only arranged by appointment and can be booked through your Authorized Maserati Dealer.

You can tailor your Maserati experience to your own personal tastes and interests by combining these and a variety of other activities:

- Visit to the Panini Museum and/or Stanguellini Museum (famous motor museums)
- Guided tour of the town
- Guided tour of a traditional balsamic vinegar manufacturer, with tasting
- Guided tour of a winery, with tasting of local wines
- Cookery school
- Day at the Modena Golf & Country Club

MASERATI COLLECTION

The Maserati Collection of leisurewear, goods and branded merchandise has been specially created for those who share the Maserati passion and who seek to associate with the illustrious marque. Maserati Collection items are available from all Maserati dealers and from the Maserati Store at the Maserati showroom in Modena. Alternatively, all the articles in the collection can be purchased online at www.maseratistore.com

MASERATI CLUB

Joining the exclusive Maserati Club means sharing thrills and experiences with other Maserati owners, and being invited to take part in special motoring events all over the world. Drivers of cars from every era can enjoy the pleasure of driving their Maseratis in a calendar of events created especially for Maserati Club members. The Maserati Club provides the link between the past, present and future of the company. For more information, visit www.themaseraticlub.com

MASERATI GENUINE ACCESSORIES

Specially conceived to satisfy our customers' needs, Maserati genuine accessories are a perfect combination of design and functionality. The attention to detail, style and quality of each individual accessory reveals the very essence of the Maserati brand, always searching for the perfect balance between comfort and performance. The car covers and car-care products are just a few examples of the Cleaning and Care line, designed to preserve the charm of Maserati cars over time. The Safety line includes child seats and a water-repellent windscreen treatment. The range is completed by the Travel line accessories, which include winter tires and a luggage compartment net, to make the most out of your car. These are just some examples of the items available, which will make the Maserati driving experience unique for our customers.

MASERATI CLASSICHE

Created for enthusiasts and owners of vintage Maserati cars, Maserati Classiche is an organization that is dedicated to those who wish to engage with the marque's glorious past. The Maserati Classiche range of products includes items that celebrate the company's 99-year history: paintings of glorious events, pictures of classic Maseratis, original reproductions of parts catalogs, owners' handbooks and old brochures, clothing, scale models and much, much more. All the latest items can be found on maserati.com in the Maserati—Maserati Classic section. Or for more information, e-mail maserati.classiche@maserati.com



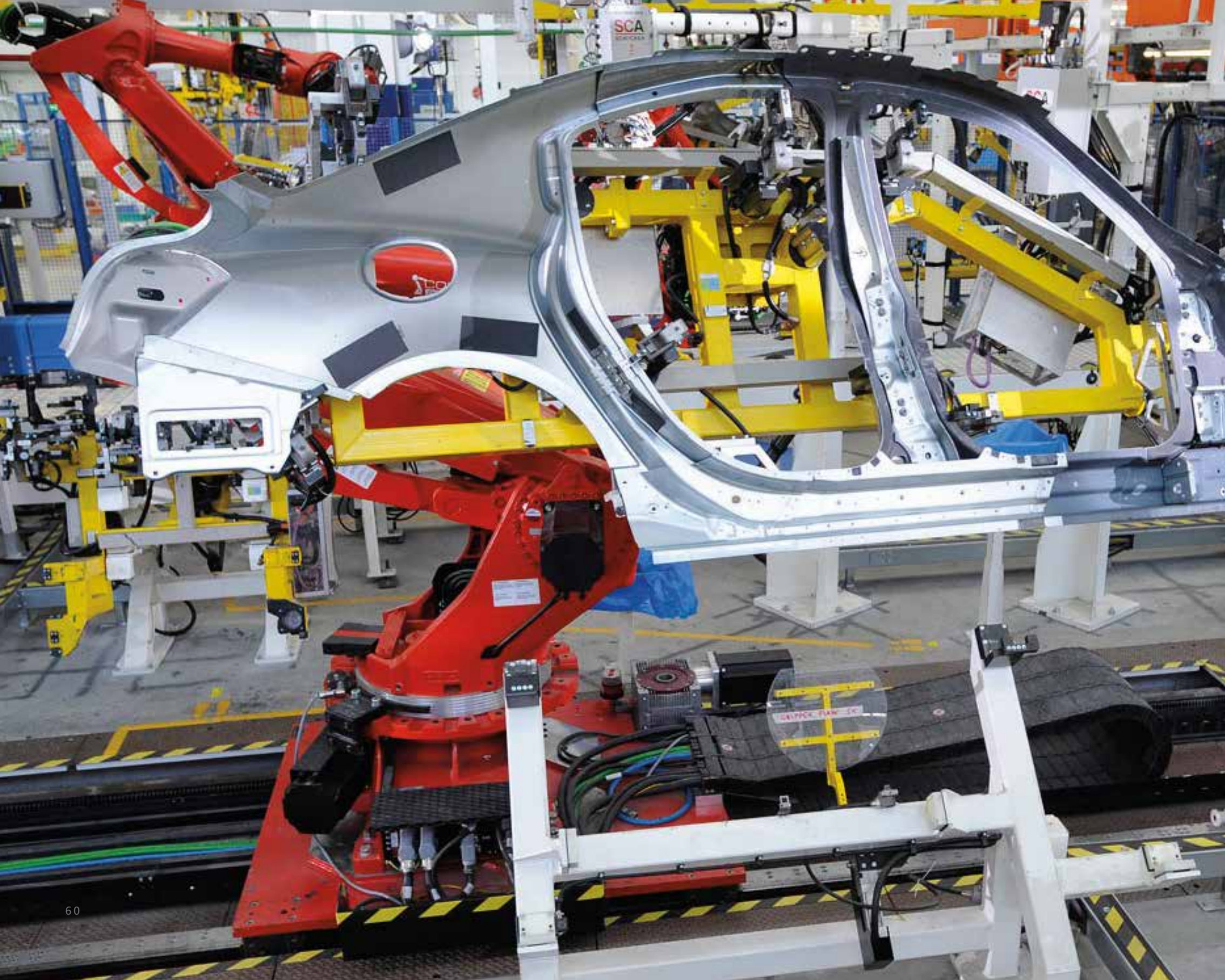

MANUFACTURING

A GLORIOUS COLLABORATION OF MAN AND MACHINE.

While Maserati Headquarters and manufacturing have long been based in Modena, Italy, production of the Ghibli is located at a recently opened Maserati plant in Grugliasco, Italy—outside of Turin. The plant is named after company patriarch Giovanni “Gianni” Agnelli, honoring Gianni’s strong connection with the Turin area. One billion euros were invested in renewing this plant, anticipating growing global sales. While the latest technology is utilized to help with fitting parts, skilled technicians man each station, keeping the assembly a handcrafted affair.

Utilizing proven practices developed through the company’s World Class Manufacturing (WCM) system, the plant has a strong culture dedicated to producing the highest quality cars possible. Each car is built to order—and with literally millions of combinations of mechanical and interior specifications possible, a document goes with each car and is signed at each station to ensure that the exact car is built to each customer’s personal requirements.

MANUFACTURING

SOMETHING THIS SPECIAL DESERVES SPECIAL WRAPPING.

After completion, the Ghibli is subjected to extensive quality-control tests, examining everything from the integrity of its weatherproofing to its handling on different road surfaces. Each car is tested on a wide mix of different local roads, including mountains, motorways and city streets. Each car goes through another series of 24 checkpoints before it is inspected again by an independent contractor, who double-checks the vehicle one more time. Finally, senior Maserati inspectors go over

the vehicle with a white-glove treatment, wrapping it in a protective covering before it makes its way to the dealer and, ultimately, the customer. It is this kind of care and pride in presentation that makes a Maserati automobile second to none.









WWW.MASERATI.US

1-877-MY MASERATI / DRIVEMASERATI@MASERATIUSA.COM

MASERATI NORTH AMERICA, INC. / 250 SYLVAN AVENUE / ENGLEWOOD CLIFFS, NJ 07632