



A6

Audi A6

Audi
Truth in Engineering



If it was this easy, it wouldn't be an Audi.

Obsession



IMAGINE DEVOTING YOUR LIFE TO BUILDING YOUR MODEL.

When you were a kid, you probably felt quite proud when you completed a model kit. We understand. At Audi, it takes countless hours for a single Audi to go from idea to design to roadworthy, and that's time we are very proud to devote. Our obsession for detail,

commitment to premium fit and finish and passion for unparalleled engineering go into every model. It's the kind of discipline that the word "painstaking" was invented to describe. Not to say it's a chore—no, assembling an Audi is a labor of love, and it shows every time you sit in one, engage the ignition and nudge the accelerator. Creating an Audi isn't easy, but the results help define what Audi means to the people who drive one.

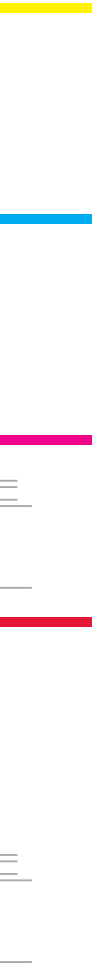
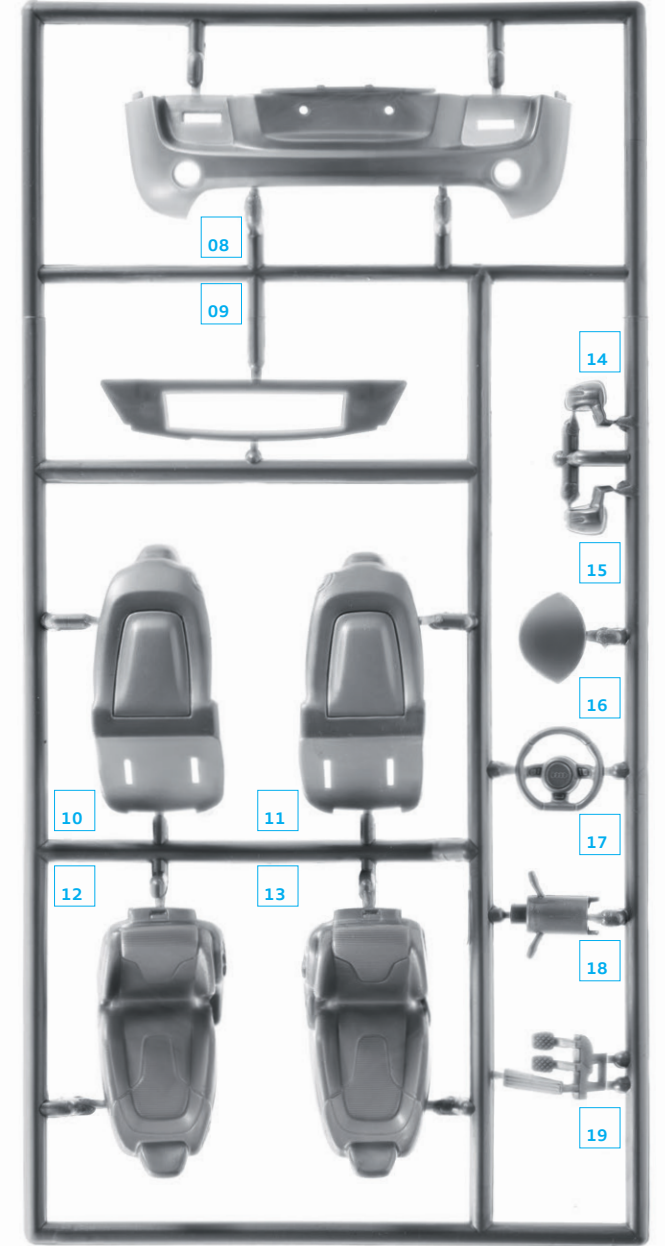
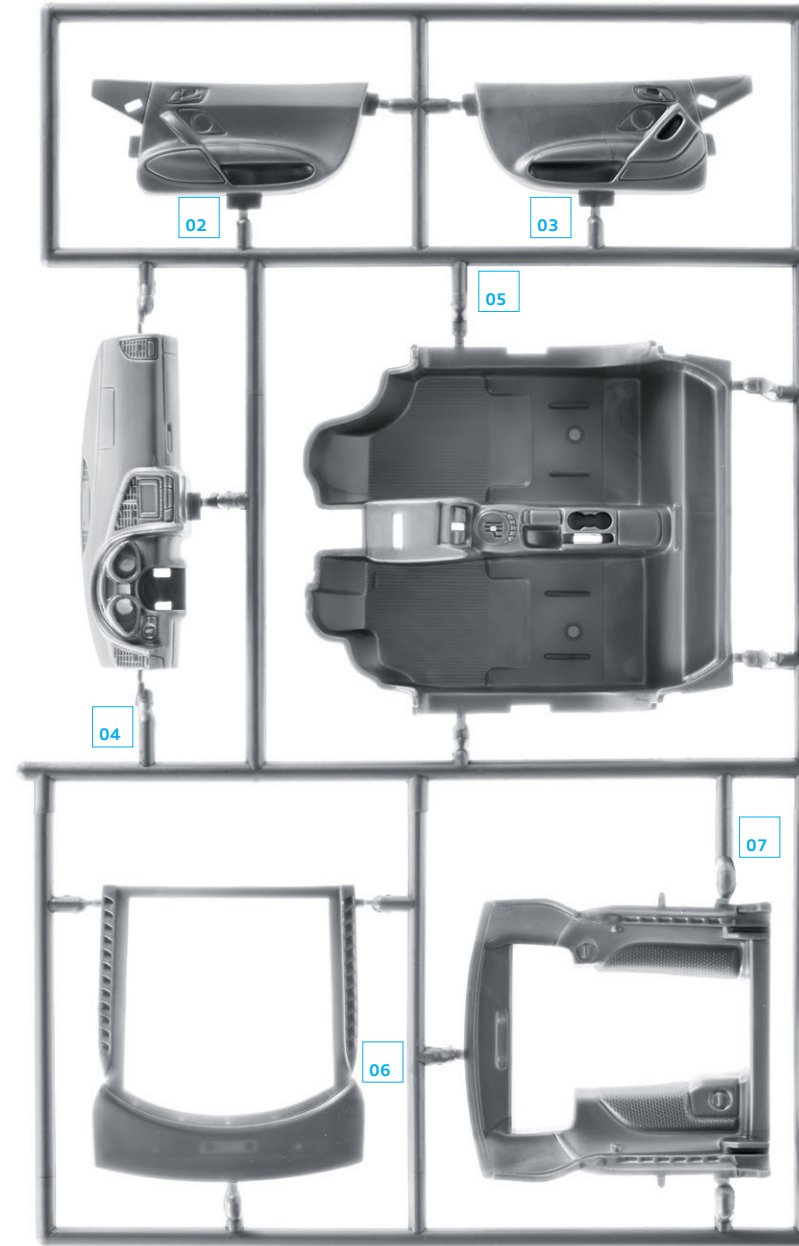



The door of perception.

OUR REPUTATION HINGES ON THE QUALITY OF THINGS YOU DON'T SEE.

It's said that, when one door closes, another one opens. It sounds as if whoever said it spent some time at an Audi research and development facility. After all, while you'll open and close the door on your Audi thousands of times without thinking about it, we've obsessed about it for you, in detail. Not just about the reliability of it opening and

closing, but on the proper weight that will make it more pleasing to close. How the locks should click when they are engaged. The optimal acoustic placement for the speaker port. There are the hinges too, of course. And the door itself, which we designed to take the brunt of side-impact collisions, and several dozen other safety considerations (to say nothing of the countless other components, processors, sensors, window features and the inner workings most people will never see). Our doors are more than a symbol of welcoming you into your vehicle, they are products of Audi engineering, and the very perception of Audi hinges on them as much as our hinges help support the door.

ACOUSTIC ENHANCEMENTS

We use soft mounts on our window regulator and a sound-absorbing backing within the door cavity itself to make the cabin even quieter.

INNOVATIVE DESIGN

By using fully pressed aluminum doors in the Audi A6, the door structures were reduced by an astonishing 44 lb compared to the previous model.

SPEAKER PLACEMENT

Optimal speaker placement helps deliver the most extraordinary sound you can find in the automotive space.

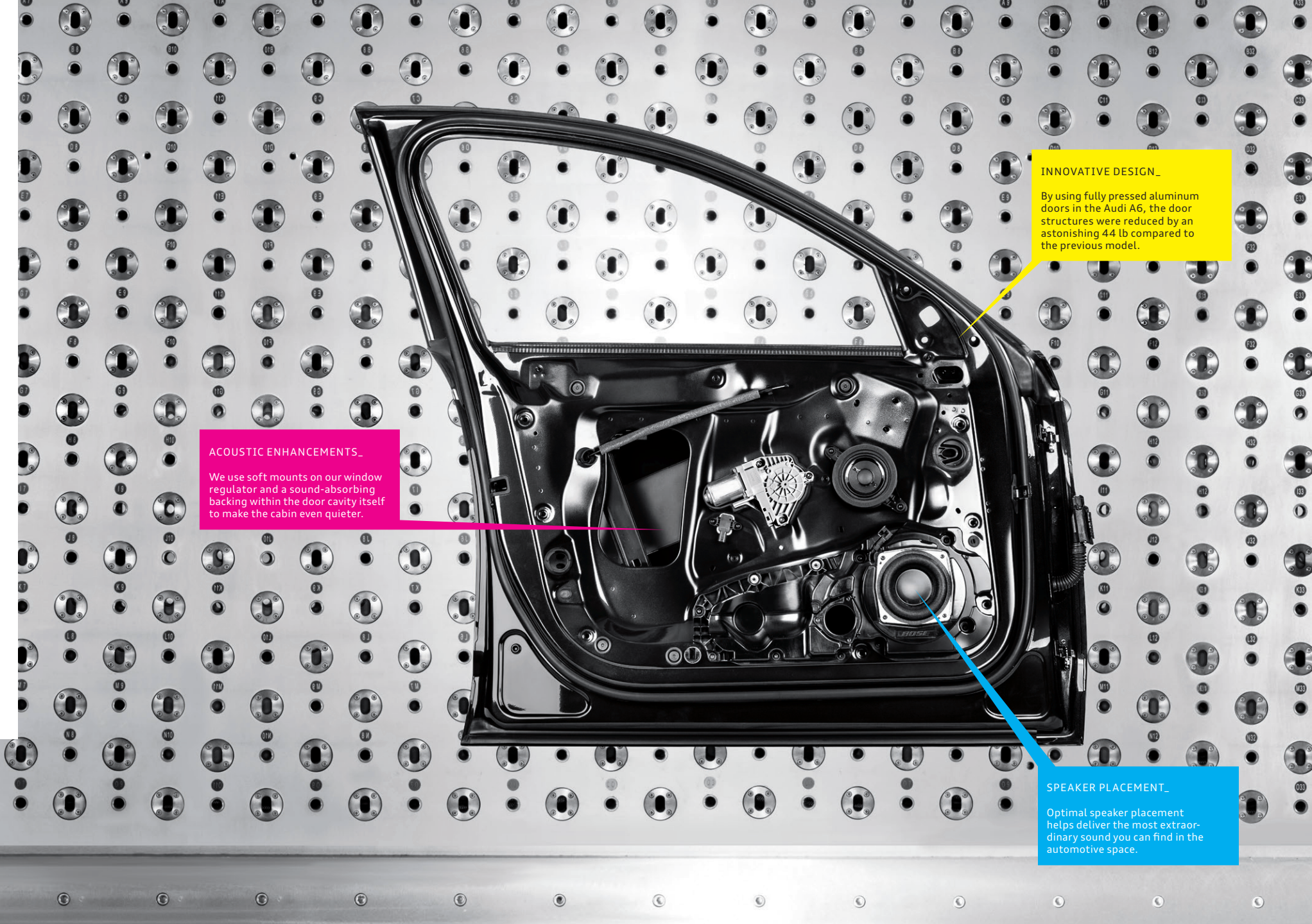

When we think of a good idea, it sticks.



SURFACES

WET
DRY
SLIPPERY
UNEVEN

Torque is distributed to all four wheels in varying amounts.

Torque vectoring

By independently braking the inside cornering wheels, torque is then transferred to the outside cornering wheels. This intelligent application of power, known as torque vectoring, is available on select quattro models and helps promote neutral handling by calculating the driver's steering input and desired level of acceleration.

Sport differential

To help ensure high cornering agility, the available sport differential uses torque vectoring, and then adds to that by mechanically applying additional torque to the outside rear cornering wheel. Through an electrohydraulic multiplate clutch pack and gear-set, the outside rear cornering wheel speed is increased by as much as 10%.

CORNERS

CURVES
MOUNTAINS
OBSTACLES
HANDLING
UNEXPECTED

Impressive stability, more assured road-holding, enhanced agility and improved steering precision.

TRACTION

ACCELERATION
TOWING
SNOW
CRUISING
GRAVEL

quattro directs the amount of torque required to suit the job at hand.

quattro® HAS MAINTAINED ITS GRIP ON OUR THINKING AND THE ROADS WE TRAVEL.

For more than 30 years, Audi has been focused on quattro® all-wheel drive. During that time, it has evolved into an overarching idea of performance, a technological system of ratios, power delivery and driving dynamics working seamlessly together, orchestrated through the drivetrain, providing power where and when it is needed most. In

many ways, this has been a three-decade drive, from the Alps to the autobahn—and points beyond. You've seen quattro® capabilities in the way we dominated the World Rally Championship for years, in the grip you have in inclement weather, and in the variable power distribution you enjoy in good conditions.¹ For more than 30 years, and with over five million quattro® systems on the road, we have continued to refine the technology, developing an available rear sport differential to help maximize performance and available torque vectoring to assist with cornering traction while helping to improve handling. We've boldly stuck to what worked while the world was trying to catch up, and we built on it.

¹ When driving during cold, rainy, snowy or icy weather conditions, ensure that your vehicle is equipped with appropriate all-season or winter tires. Even with appropriate tires, you must always drive in a manner appropriate for the weather, visibility and road conditions.

The obsessive engineering of maximum fitness.

ENGINEERING POWER IS MORE THAN JUST ADDING MUSCLE.

There is an art to fitness. Yes, there are some who go for the massive, sculptured muscle look. But there is something more compelling out there for those with more refined tastes. The kind of sculpted efficiency found in Audi engines elevates the driving experience through smaller, finely tuned forced-

induction engines. For the drive to feel lean and precise, we've shaved off unwanted pounds. Sure, large numbers might distract some, but a champion impresses with its grace, power and athletic balance—captured in the right suspension setting, or a torque-vectoring corner. Audi engineers taste strength that pulses at the moment of acceleration, provides a true, quick response as you change lanes, and turns the most routine cloverleaf into a joyful application of performance handling¹. This is the art of maximum fitness, to the point where others just feel a little flabby.

FSI[®]

The FSI direct injection fuel system directly injects fuel into the combustion chambers at precisely managed times and depths. What that means for drivers is that a fully homogenized intake charge helps increase power while also reducing fuel consumption and emissions, making efficiency more powerful.

TFSI[®]

At Audi, TFSI represents a combination of two of the brand's core areas of expertise—direct injection and forced induction. By adding turbocharging or supercharging to FSI direct injection, the pressurized intake charge is cooled by directly injected fuel, thus achieving efficiency and performance combined with higher compression ratios—previously only attainable by naturally aspirated engines.²

TDI[®]

A turbocharged, fuel-sipping variant, our TDI clean diesel engines deliver uncompromising Audi performance with bold efficiency¹. Yes, it gets better mileage per gallon than comparable gasoline engines², but it also produces more low-end torque, which is best expressed in the elasticity you have when passing in the 30- to 60-mph range.

¹ Always obey all speed and traffic laws.
² See www.fueleconomy.gov for EPA estimates and emissions data. Your mileage and emissions will vary and depend on several factors, including your driving habits and vehicle condition.

ELEPHANT SKULL_

How nature solved the apparent conundrum of an elephant's skull didn't escape the notice of Heinrich Timm, the longtime lead engineer for Audi. The weight of the tusks and the general size of an elephant's head would seem to make it impossible for the animal to actually be able to carry it. But the design genius behind the elephant's skull is to make it lightweight yet sturdy. Its predominantly hollow design is buffered by thin, connective bone walls, which act as strong, weight-bearing cells. Audi designers used that idea when building our aluminum and steel structures. Reducing weight, yet enabling strength.



ultra

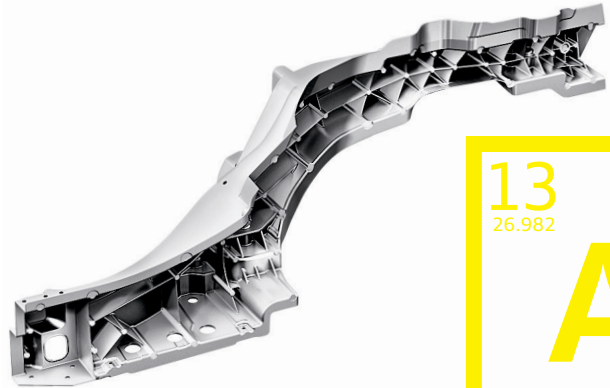

13
26.982

AU

ALUMINUM_

Our large aluminum castings are a telling example of ultra lightweight technology. Primarily used in high-stress areas, these castings achieve exceptional rigidity while also allowing for freedom of design, all while remaining extremely lightweight!

How studying elephant skulls makes for superior handling.

THE ELEGANT STRUCTURE OF NATURE BECOMES A BLUEPRINT OF EFFICIENCY.

It seems strange to say that, while we build strong, complex and high-performing machines, we're naturalists at heart. Then again, it might not be that unusual, seeing how nature itself builds strong, complex and high-performing machines as well. When we developed the thinking behind our ultra® lightweight technology initiative,

we knew that nature would serve as an inspiration to greater structural efficiency. Take the structure of the elephant skull pictured here. It has to be lightweight, yet capable of carrying a heavy load. It's porous, but its structure is such that it enhances its stability and strength. We do the same, for example, with aluminum. Positioned one way, aluminum materials can be flexible. Positioned another, they are strong and rigid, and help give better support. We also looked to bamboo, which is strong at the conjoined areas (nodes), and flexible along its stem. Our designs allow for both rigidity and flexibility where each is most needed, and for efficiency overall. As we continue to develop strategies to improve the performance aspects and efficiency of our vehicles, we don't shy away from the world around us? We boldly engage it even closer still.

1. Features and technologies listed are not available on all models. 2. See www.fueleconomy.gov for EPA estimates and emissions data. Your mileage and emissions will vary and depend on several factors, including your driving habits and vehicle condition.

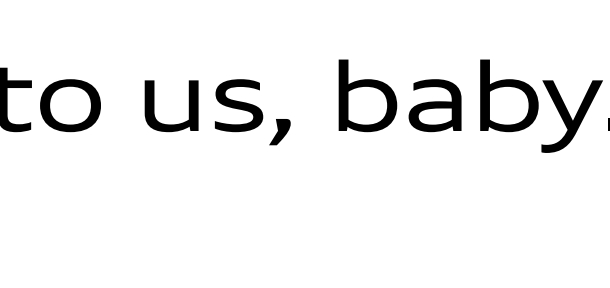

Just talk to us, baby.



AUDI CONNECT® REALLY GETS WHAT YOU ARE SAYING.

Share what's on your mind. Looking for a great Chinese food place? We'll help you get there. Thinking about a rest stop? We'll locate the nearest gas station for you, and even give you the price of their fuel. In fact, in your Audi, just say the word, and we'll help you find almost anything, even your home phone number. With available Audi connect with Google

Voice™ command capabilities, we've developed a way to let you articulate your desires, even if that's just finding the closest burger stand or the best hotel.¹ MMI® navigation plus with Audi connect helps integrate networking capabilities on the go, along with Google Earth™ with 3D satellite imagery, to help you avoid traffic (and possibly saying things you might regret)² Audi connect also provides fast data transfer speeds and Wi-Fi® connectivity for up to eight passenger devices to help you stay informed. It offers a full suite of services and interactivity, and, yes, even the closest Szechuan restaurant, which you can find by using its Google™ Local Search capabilities. Best of all, you don't even have to say "Thank you," even if we appreciate it when you do.

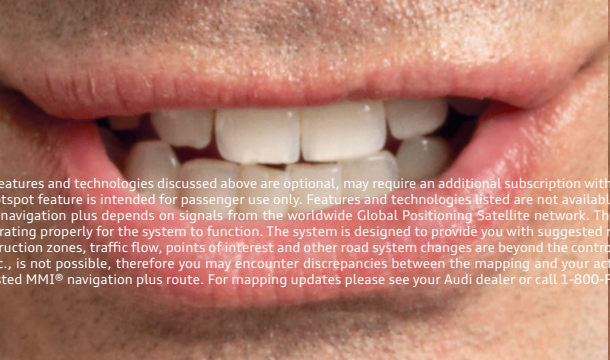
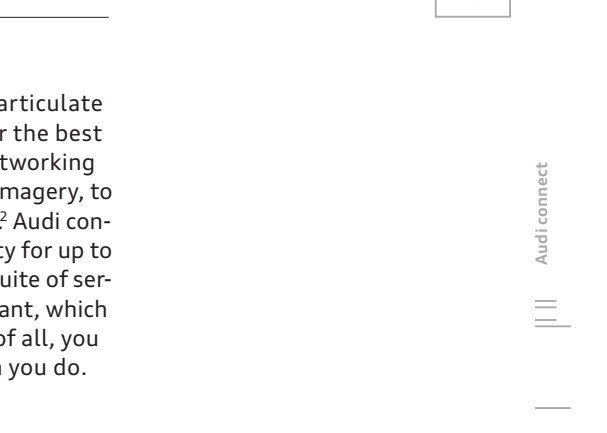
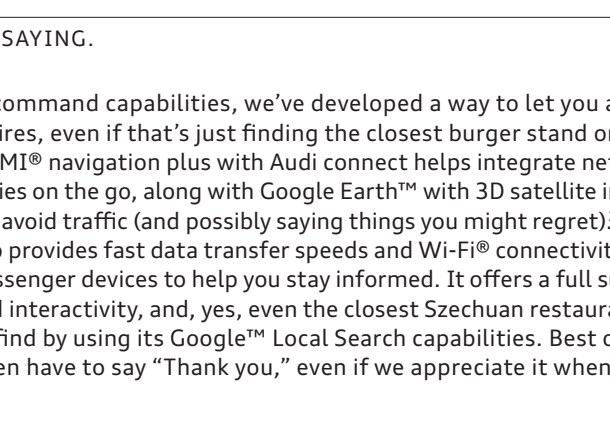
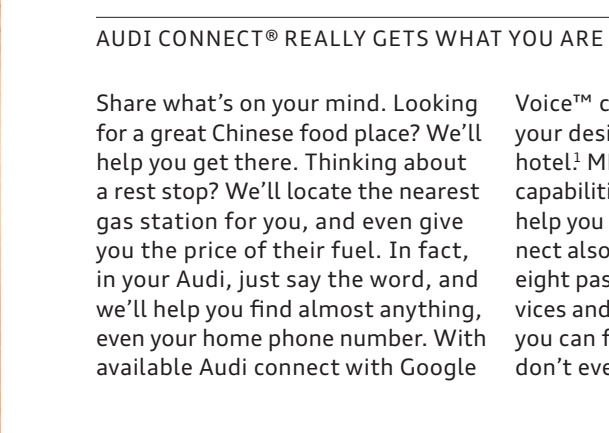

1. Always pay careful attention to the road, and do not drive while distracted. The features and technologies discussed above are optional, may require an additional subscription with separate terms and conditions, and should be used only when it is safe and appropriate. The Wi-Fi® hotspot feature is intended for passenger use only. Features and technologies listed are not available on all models. The voice control feature is not available on Cabriolet or Roadstar models. 2. MMI® navigation plus depends on signals from the worldwide Global Positioning Satellite network. The vehicle's electrical system and existing wireless and satellite technologies must be available and operating properly for the system to function. The system is designed to provide you with suggested routes in locating addresses, destinations and other points of interest. Changes in street names, construction zones, traffic flow, points of interest and other road system changes are beyond the control of Audi of America, Inc. Complete detailed mapping of lanes, roads, streets, toll roads, highways, etc., is not possible, therefore you may encounter discrepancies between the mapping and your actual location. Please rely on your individual judgment in determining whether or not to follow a suggested MMI® navigation plus route. For mapping updates please see your Audi dealer or call 1-800-FOR-AUDI for details. Features and technologies listed are not available on all models.



Hey, bright eyes.



DESIGNING A WINDOW TO OUR SOUL.

Even in the dark, you know when you're staring at an Audi. In fact, it might just be love at first sight. That's because, instead of cursing the darkness, we celebrate the light. Available full LED headlights stand out from the rest: their color inten-

sity is engineered to be reminiscent of daylight. But while we illuminate the night, we don't forget the day—so we made our LED daytime running lights to look even more dramatic. Now featuring a sleek diode design that gives us the freedom to elegantly reshape our signature style, Audi LED lighting is once again ours. It is an efficient, beautiful way to help you see and be seen from dusk to dawn and back again. Look deep into our eyes, and you might just see the soul of a company.



How we know exactly what you feel.

CLEAN, BEAUTIFUL DESIGN COMES FROM DEDICATED CRAFTSMEN UNAFRAID OF GETTING THEIR HANDS DIRTY.

Our hands give you shade and sanctuary. Our hands give you comfort and control. You might not sense our hands nearby, but our hands know exactly what you feel. That's because we've been there. After all, our hands crafted a customized world that's dedicated to control, comfort and entertainment. We're talking,

of course, about the cabin of your Audi vehicle. Optimized luxury, designed by committed craftsmen who had you in mind when they chose the leather seating surfaces, created the contoured seats or provided the refinement of ergonomic design and an available more intuitive MMI® system. There are small touches that help simplify the overall design, and there are large statements to help you feel at ease. It is your Audi interior, shaped by the kind of people who know you want to experience luxury firsthand.



As you can see, our design will help channel water away from the mirror, allowing you a clearer view of what's behind you.



The molding on the inner A-pillar helps direct water away from the area where the windshield and A-pillar meet. Once the water is there, aerodynamic forces take over and funnel the water up and out of the windshield area rather than back and across the side windows.

You have to weather adversity to know things like this.

WHAT YOU DON'T KNOW MIGHT HELP YOU.

Think of it this way—if it rains, would you notice a dry side view mirror? Maybe not, but compared to one with beads of rain on it and distorted reflections, you would. It's a little thing, perhaps, but these little things are part of our deep obsession with crafting a premium driving experience.

We design our exterior side mirrors with small sills to channel water along their upper edge, helping leave your view unobstructed. We also design our windshield moldings with channels that allow rain water to efficiently run off instead of returning to the windshield wiper path. These are small touches, thought of by engineers and crafted by designers who don't necessarily call attention to their skills. Instead, these details reflect a commitment to quality that you might never notice—until a moment of bad weather or adversity, when you might. But don't worry. We don't mind if you don't notice us, now and then.



Either think about the future, or make history.



e-tron

e-tron®



SUPREMELY PRACTICAL LUXURY WITH A SUNNY KIND OF ENERGY.

Talking about a better future is easy. After all, how can you be held accountable for something that never arrives? But if you really want to affect it, to make history, you have to do more than talk. Enter e-tron®. It's not the first plug-in electric hybrid to the market, but we are making it the most forward-thinking Audi ever produced. For example, we will be including a

level 2 charger with our A3 Sportback e-tron PHEV for owners who want to drive on electricity as much as possible. We also plan to offer unique sustainable energy offerings like an available solar powered connection to your charger. It's not just practical, it's premium too, in style, in performance and in fit and finish, like any other Audi vehicle. The A3 e-tron will be able to take on the average daily commute on electric-only before the efficient 1.4 TFSI® gas engine is needed.¹ But more than that, it will be Audi making smart technology smarter, with innovative kinetic-energy-harnessing when you brake, and better performing than what came before it. With the Audi e-tron vehicles, we're saying the future is now.

¹ Preliminary manufacturer's estimates.

Pre-production vehicle shown.



The little things that add up

01 Audi connect
Our Google™ powered information system.¹

02 Audi Care
Available convenient service option.

03 MMI updates
MMI navigation and other software updates.¹

04 SiriusXM® Satellite Radio
Endlessly diverse music channels with a complimentary trial offer.¹

05 Audi exclusive
Available customizable exterior and interior color and material options.

SENSE OF HUMOR

RESOURCEFUL

ROMANTIC

SENSE OF STYLE

GENEROUS

LOVING

to a long- term love.

MOVING FROM LUST TO APPRECIATION TAKES A DEEPER UNDERSTANDING.

When you are attracted to something, the effects are immediate, the domination, total. For a relationship to last, though, it must move beyond that passionate initial phase. It's what comes next that turns a bright flame into an eternal torch. That's why Audi doesn't simply design premium vehicles for the

short-term, but offers an entire experience that we hope lasts a lifetime. Do you want to customize your Audi? We offer Audi exclusive materials and colors. Do you want care-free service options? Audi Care is available. MMI® updates, trial offers for Audi connect®, a full suite of available Audi driver assistance technologies—these might not be the reasons why you fell in love with an Audi, but they are, perhaps, the things that help keep the heart fires stoked.¹

¹ Optional features and technologies listed are not available on all models. See Infotainment/Technology section of the Featured Content page for important information regarding MMI® navigation plus and required SiriusXM® subscriptions.

THE TRUTH IS
SELF-EVIDENT
TECHNOLOGY, IN
IN THE KIND OF
THAT TAKES OWN
ONE TO APPRE
JUST HOW AD
IN THE **A6**: IN
PERFORMANCE,
ENGINEERING
ING
CIATE
VANCED IT FEELS.

Inspirations that build an icon.

The alchemy needed to build an automotive icon is elusive. Sure, it's found, partly, on an assembly line, with committed artisans taking pride in every stitch they oversee. It's also on a drafting board, sketched by visionaries looking to further expand what we look for in automotive design lines. But it's also in the countless inspirations, ones little and large, that not only capture a bold thought or striking idea, but execute them. Examples of these can be found in the foundational stories we tell about our company and our vehicles. These stories show how an abstract idea can turn into a powerful, sculpted machine, and then how that machine can help forge an iconic reputation for a brand. Out of the inspirations we find in engineering, art and the large world of ideas, we have created a fearless, iconic company of substance and luxury: Audi.



Design

We do not follow design trends. We set them.



Conversations that lean on theory just aren't our style.

Some lessons are better learned by seeing rather than by listening. Consider this a good thing, then—the Audi A6 is a visual lesson in luxury design. Clean, assertive lines mark the beginning of the education with style. Class continues with the signature Singleframe® grille up front, and a pair of beautifully sculpted exhaust outlets out back. From there, the course branches out into the seemingly relentless grip of available quattro® all-wheel drive, and an available supercharged 3.0-liter TFSI® V6 engine, which gives you the muscle of a V8 with the thirst of a V6! Now you have the uncompromising performance of a technologically advanced luxury sport sedan. From every angle, it commands attention. With every drive, it enlightens.

¹ 2015 EPA estimates and emissions data not available at time of printing. See www.fueleconomy.gov for updated information. Your mileage and emissions will vary and depend on several factors, including your driving habits and vehicle condition.



Enlighten

A new light on illumination just happened to be a design boon.

Groomed for the lead role.

It's been said that great writers start with one exceptional character and let the plot organically build and flow from there. We took a page from their book, so to speak, when designing certain aspects of the Audi A6. Specifically, our signature LED lighting technology. Developed with purpose in mind, it ended up serving as an equally brilliant design feature. Just consider the formation of the available full LED headlights. The design not only spreads light evenly across the road, but plays a central role in the vehicle's character. From there, the story progresses one line at a time, starting with something we call the Tornado line. Bisecting the body profile, it runs strongly through the middle of the vehicle to give it a bold, progressive stance that tells the world that here begins a narrative that is uniquely yours.



When it comes to energy density, diesel has gasoline beat—period. This helps give the available TDI® clean diesel engine its initial performance advantage. From there, its advanced technology and potent low-end torque do the rest to prove its point.

Progress often requires leaving a few things out.

Some people like to fight it, others willingly embrace it. However you feel about it, you can put us down as being bullish on progress. In fact, you can clearly see our position on this with the Audi A6. Crafted with precision, appointed luxuriously and built with performance in mind, while being connected like no car before. And just to parade our commitment to progress, you can enjoy all the low-end torque and driving-range provided by our available TDI® clean diesel engine. The A6 was not built for those content with standing still, but for those who see progress as the only way to move forward.



Now, nothing is out of reach.

Imagine that this is how life looks from this point forward. Take a moment to indulge in the wraparound curve of the Audi A6 dashboard. See how it integrates intuitively with the overall driver-centric layout. Discover the design interplay between the available MMI® navigation plus with its eight-inch display deploying from and retracting into the instrument panel and the three-spoke multifunction steering wheel with shift paddles. Then admire the finely crafted decorative inlays displayed before you. Now imagine you just shifted into Drive. The world is undeniably yours for the taking.



Craftsmanship

We've ensured that every stitch represents the detail that we put into every aspect of an Audi vehicle.

A fair comparison may be hard to come by.

Balance has never been a prerequisite for passionate design. Maybe that's why nothing, from the gleaming aluminum-trim surrounds to the burnished decorative wood inlays, is symmetrical. We considered every component of the interior and found that the people interacting with it would have different needs. So the wraparound interior isn't in balance—it's designed to meet the particular needs of the driver or the passenger. We feel this is a uniquely Audi perspective, to design with an imbalance in mind. From the layout of the dash to the luxurious materials and top-flight craftsmanship, we are proud to stand apart. Crafted with an eye on originality, the Audi A6 interior provides a welcome contrast to those obsessed with all things being equal.



Decorative inlays

Incorporating painstaking craftsmanship, the Audi approach to our wood and aluminum-trimmed inlays is the same as it is to our engineering. Imperfection is not an option. So natural wood shines, and aluminum glistens. We capture the right accent of your interior choice, and add a singular finish to its fit.



Leather

Designed specifically for Audi, leather envelops the vehicle's seating surfaces, to add the right touch to your luxury interior.

Audience participation is encouraged.

There's a reason we keep pushing our innovative design team to change the way you interact with interior appointments, and it centers on an enduring drive to create style with purpose in mind. With luxurious materials, available twelve-way power front seats and four-zone automatic climate control in the Audi A6, you literally create a unique cabin environment to fit your own unique style. This is true for the smallest details too, like an available heated steering wheel, or heated and ventilated front seats that help keep you comfortable. All this so that, when you get in, what you experience is luxury perfection.



Typecast as an action lead.

We're sure it will come as no surprise when we tell you the Audi S6 was made for this role. But you could have guessed that with just a glimpse of its commanding profile. Or by the roar of its 4.0-liter TFSI® V8 that produces an unrelenting 420 hp, while helping save fuel using cylinder on demand™ engine efficiency technology. But what's power without control? That's where the legendary quattro® all-wheel drive system comes into play, not to mention the sport differential and Audi adaptive air suspension. And, as a final show of its ability to mesh luxury and power, it offers signature sport seats with integrated head restraints. Breaking character is not an option here.



Audi Sport
Truth in Engineering



The story doesn't stop here. There's more on the full range of S, RS, and R8 Audi performance models in the **2015 Audi Sport brochure**. See your dealer or go to audiusa.com for details.

1 17 city/27 highway/20 combined mpg (2015 Audi S6 4.0T with seven-speed S tronic® dual-clutch transmission and quattro® all-wheel drive). EPA estimates. Your mileage will vary and depends on several factors, including your driving habits and vehicle condition. 2 Top track speed is electronically limited in the U.S. Always obey all speed and traffic laws.

S6



ENGINE // 4.0-liter turbocharged TFSI® V8 engine developing 420 hp and 406 lb-ft of torque

DRIVETRAIN // quattro® all-wheel drive with sport differential
Seven-speed S tronic® dual-clutch transmission

CHASSIS // S6 tuned Audi adaptive air suspension, Audi drive select

BRAKES // 15.7" ventilated front disc brakes with S6 logo, 14.0" ventilated rear disc brakes

PERFORMANCE // Top track speed of 155 mph²

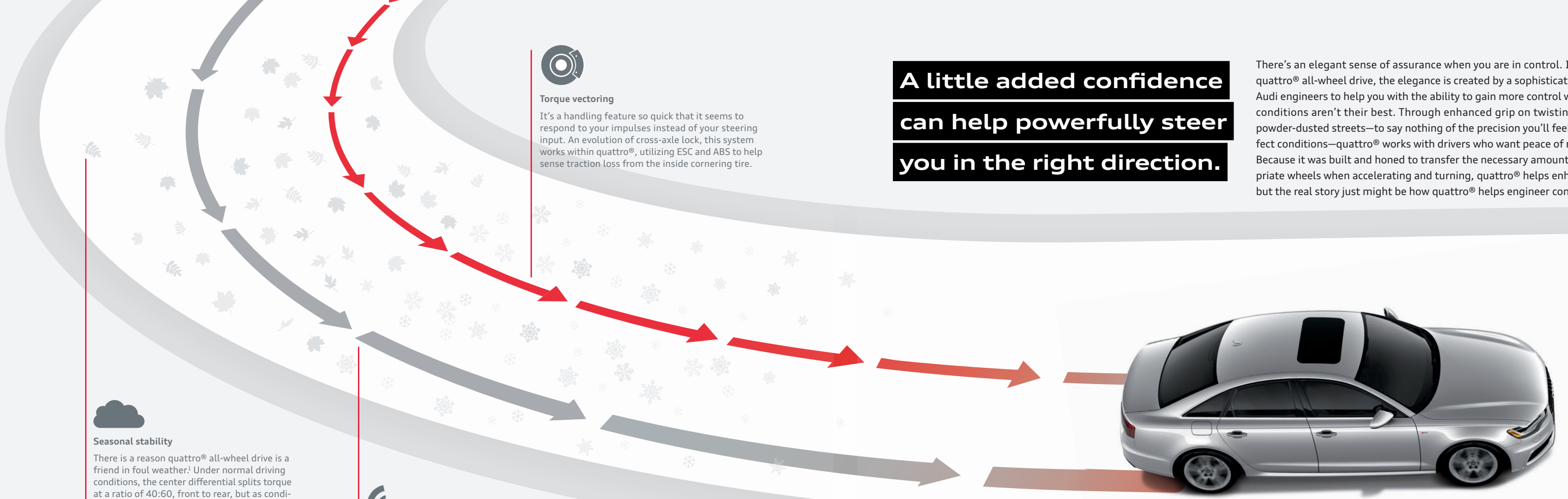

**A little added confidence
can help powerfully steer
you in the right direction.**

There's an elegant sense of assurance when you are in control. In the case of available quattro® all-wheel drive, the elegance is created by a sophisticated system developed by Audi engineers to help you with the ability to gain more control when road and weather conditions aren't their best. Through enhanced grip on twisting mountain roads and powder-dusted streets—to say nothing of the precision you'll feel in taking corners in perfect conditions—quattro® works with drivers who want peace of mind as much as power. Because it was built and honed to transfer the necessary amount of power to the appropriate wheels when accelerating and turning, quattro® helps enhance Audi performance, but the real story just might be how quattro® helps engineer confidence in good drivers.



Torque vectoring
It's a handling feature so quick that it seems to respond to your impulses instead of your steering input. An evolution of cross-axle lock, this system works within quattro®, utilizing ESC and ABS to help sense traction loss from the inside cornering tire.



Seasonal stability
There is a reason quattro® all-wheel drive is a friend in foul weather.¹ Under normal driving conditions, the center differential splits torque at a ratio of 40:60, front to rear, but as conditions change and become more challenging, the ratio is optimized to help maximize grip.



Power out
Torque vectoring distributes power to the outside wheels when turning, helping give you added control in the corners.

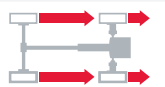

85:15
When accelerating, power is shifted to the rear wheels for extra rear traction.

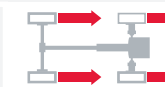

Under normal driving conditions, power slightly favors the rear axle.

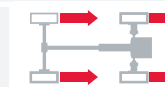

quattro® seamlessly transfers power as needed as driving conditions change.

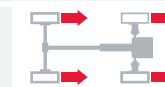

30:70
When traction is limited at either axle, power is shifted to the axle with the most traction.

¹ When driving during cold, rainy, snowy or icy weather conditions, ensure that your vehicle is equipped with appropriate all-season or winter tires. Even with appropriate tires, you must always drive in a manner appropriate for the weather, visibility and road conditions.



A

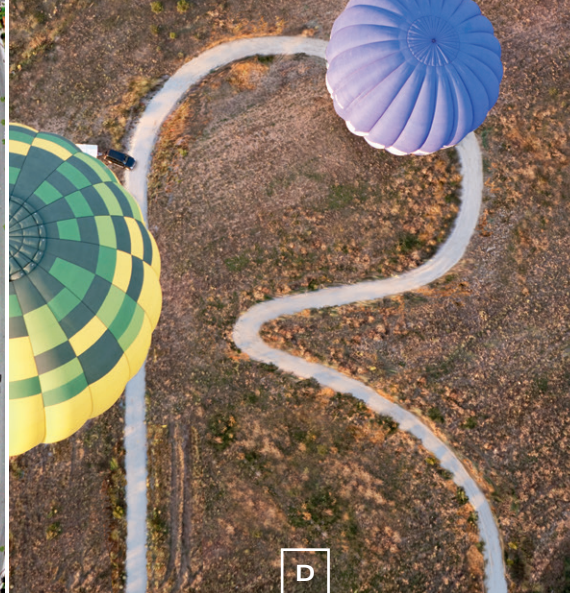

D



C

C



C

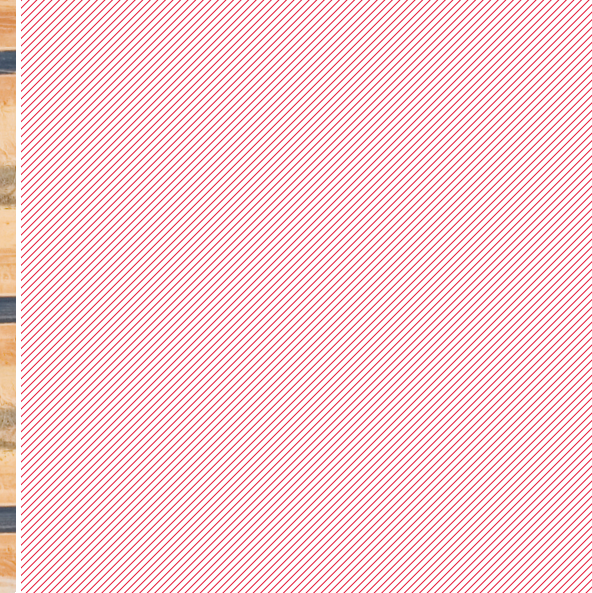

C

Comfort mode

Perfect for those long highway stretches, this setting adds optimized steering and a closer shift pattern to help provide a more relaxed drive.

D

Dynamic mode

Tighter steering and a more responsive throttle give this setting an aggressive feel and focused performance.

A

Auto mode

The best of both worlds, dialed to automatically adjust settings for a seamless combination of comfort and responsiveness based on your driving style and road conditions.

I

Individual mode

Take the turn your way—this mode allows you to adjust the steering, throttle and transmission upshifts to your style.

At Audi, we believe you should be the ultimate master of your road-going domain. That's why we created the Audi drive select system. It gives you the ability to adjust the vehicle's steering, throttle response and transmission shift characteristics with the utmost of ease. And with four modes to choose from, when almost any kind of road comes into question, Audi drive select will let you answer.

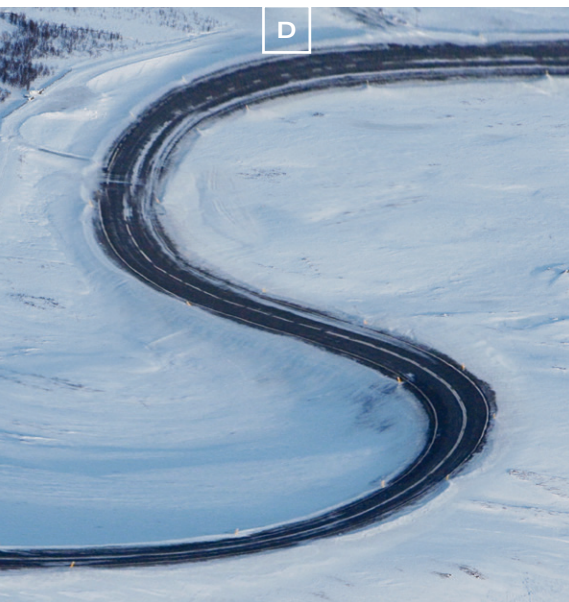

D

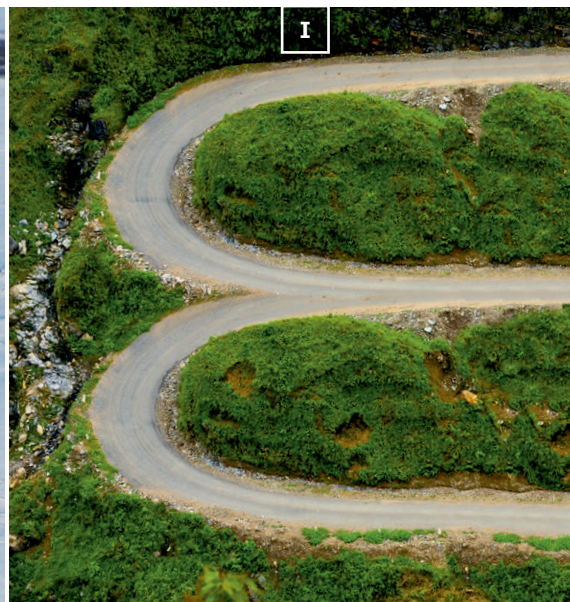

I



C

I



D

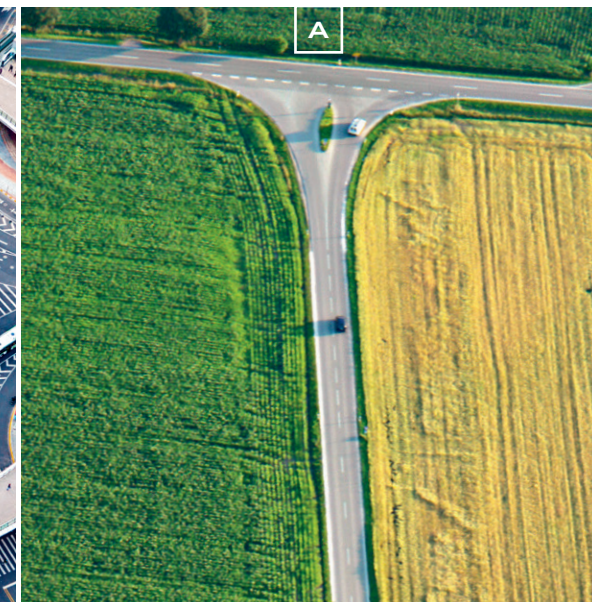

A

This is how power accelerates.

For us, losing weight has nothing to do with vanity. It's all about making us stronger and more agile. By reducing the weight of the chassis and engine, we are able to harness more power more quickly—and, not incidentally, more efficiently.¹ That means the Audi A6, equipped with the available supercharged 3.0-liter TFSI® engine, delivers the potent acceleration of a traditional V8 with the efficiency of a V6.¹ Improved miles per gallon¹ and more beats per minute? We call that a win-win.

Induction technology—TVS supercharger

Compressing the airflow to the engine forces more air into the cylinder and, ultimately, more power from each ignition, helping to improve the engine's power-to-displacement ratio.

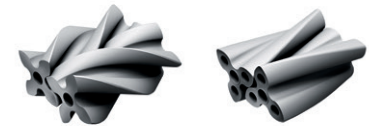
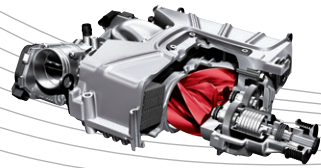

Four-vane w/160° twist Three-vane w/60° twist

Performance

The adage “good things come in small packages” has never been more true.

↑ ↑

More twist for power

Modern supercharger rotor-vanes have a 160° twisted shape for higher pressures and improved efficiency. And by using a four-vane design instead of a three-vane design, thermal efficiency and air-handling characteristics are improved without increasing the size of the supercharger unit.

310 horsepower

325 lb-ft of torque

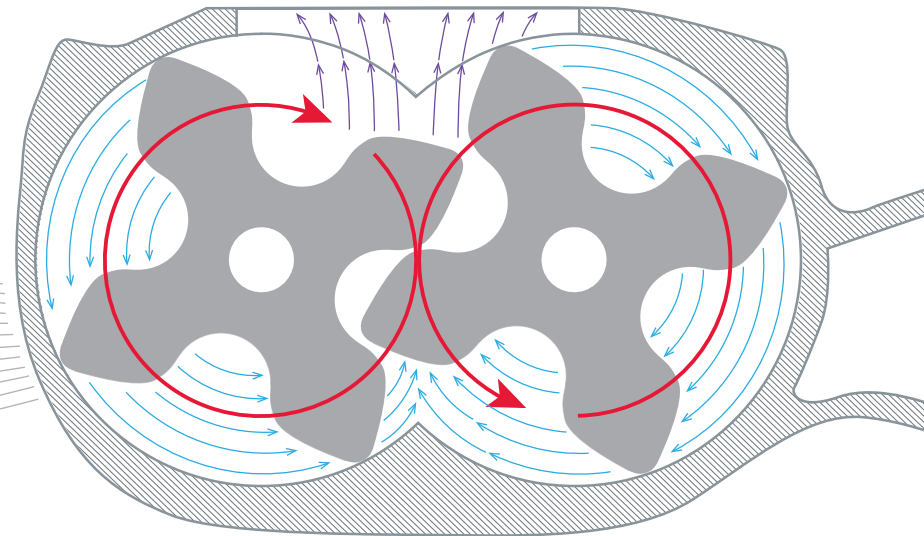

3.0 TFSI V6

The 310-horsepower 3.0-liter TFSI V6 engine is paired with FSI® direct injection and a belt-driven supercharger that has counter-rotating four-vane rotors that force air through dual intercoolers at boosted pressures. It is this combination of engineering achievements that allows for nearly instantaneous buildup of 325 lb-ft of torque directly off idle engine speeds.

Start-stop efficiency system

As an intelligent vehicle system, this available highly effective engine management program can lower fuel consumption as well as CO₂ emissions by automatically shutting off your engine while you wait at a red light or, perhaps, during certain stop-and-go driving. Once you are ready to resume, or if other critical vehicle systems require it, the engine will restart nearly instantaneously.

2.0 TFSI four-cylinder

This 2.0-liter turbocharged DOHC engine produces 220 horsepower and 258 lb-ft of torque, and combines the valvelift system, FSI® direct injection and turbocharging for great power and overall performance.

Eight-speed Tiptronic® automatic transmission

As the perfect companion for almost any road trip, the eight-speed Tiptronic® automatic transmission available in the Audi A6 offers eight optimized, carefully chosen gear ratios. Selected automatically or via its console-mounted shifter or steering wheel-mounted shift paddles, precise shifts are delivered without sacrificing the smooth action of the Tiptronic® automatic. A high final drive ratio allows optimization of lower gears, yet the transmission's upper range emphasizes fuel economy—particularly at highway speeds.¹

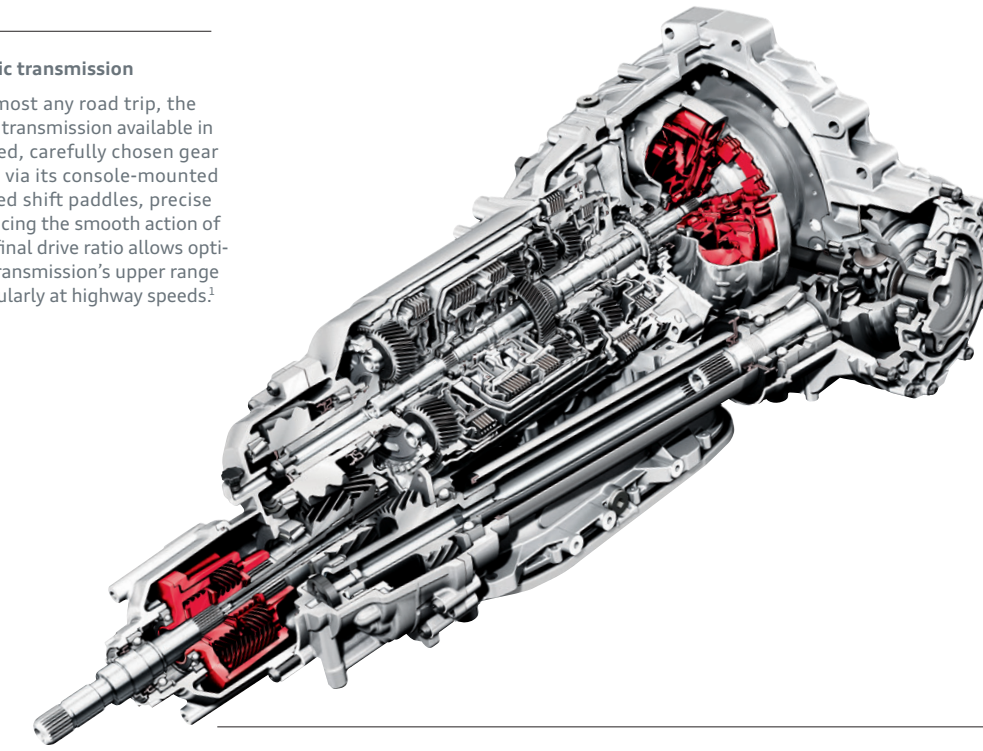

| gear | ratio |
|------|---------|
| 1ST | 4.714:1 |
| 2ND | 3.143:1 |
| 3RD | 2.106:1 |
| 4TH | 1.667:1 |
| 5TH | 1.285:1 |
| 6TH | 1.000:1 |
| 7TH | 0.839:1 |
| 8TH | 0.667:1 |

With efficiency comes great power.

Legendary engineering has shifted gears once again. Not content with a heritage of performance, we've developed an even more responsive and efficient way of applying power.¹ Our available revolutionary eight-speed Tiptronic® automatic transmission with Dynamic Shift Program (DSP) helps to enhance performance while also allowing you to command upshifts or downshifts through the steering wheel-mounted shift paddles. A new gear has been found—what you do with it is your choice.

multitronic® transmission

As a continuously variable transmission, the available multitronic combines the efficiency of a manual gearbox with the convenience of an automatic transmission.¹ And thanks to its variable ratios and adaptive map control, the multitronic always utilizes the optimal rev range of the engine.

¹ See www.fueleconomy.gov for EPA estimates. Your mileage and emissions will vary and depend on several factors, including your driving habits and vehicle condition.

Fuel for thought.

We thought you should know: Diesel sports a greater power density than traditional gasoline, which means that a gallon of diesel fuel has about 15% more energy than a comparable amount of gas, and combusts more efficiently in the engine. The TDI® clean diesel engine available in the A6 has achieved ultra-low emissions vehicle (Bin-5/ULEV II) status in all 50 states while producing approximately 15.3% fewer CO₂ emissions than its comparable gasoline-fueled engine.¹ And the brainy attributes don't hide the brawn—in fact, Audi has dominated the 24 Hours of Le Mans over the years with TDI® prototype race cars. With these facts in mind, maybe you are thinking that a TDI® might be your choice—which goes to show that clean diesel really is fuel for thought.

→ → → TDI® clean diesel

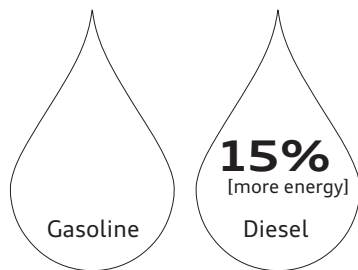

↑ ↑

Diesel packs more energy

On average, one gallon of diesel contains about 147,000 BTUs, versus 125,000 for gasoline.

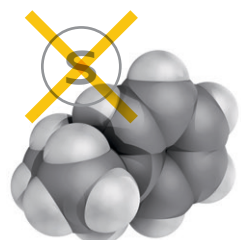

↑ ↑

Making diesel cleaner

A new refinement process has reduced sulfur in diesel fuel by more than 97% in years past.

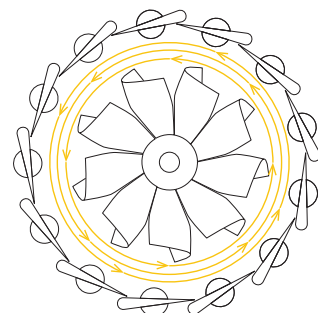

↑ ↑

Variable vane turbocharger

Adding turbo power to clean diesel engines, our variable vane turbocharger produces impressive torque punch at mid-range highway speeds.²

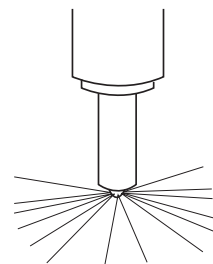

↑ ↑

Piezo direct injection

Precise injections help lower the combustion noise normally associated with diesel engines, while optimizing the distribution of fuel in the combustion chamber, helping to further reduce exhaust emissions.

| | | |
|---|---|---|
| ↓ ↓ mileage | ↓ ↓ range | ↓ ↓ torque |
| 24 city/38 highway/29 combined mpg ³ | Up to 460 (city) or 729 (highway) miles per tank ⁴ | 428 lb-ft of torque along with 240 hp from the 3.0-liter TDI® clean diesel V6 |

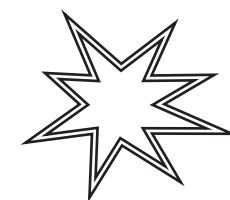

↑ ↑

Combustion

Combining a high compression ratio with direct injection makes combustion more efficient, and produces emissions cleaner than those of engines with a lower compression ratio.

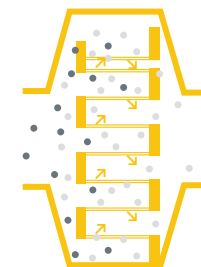

↑ ↑

After-exhaust treatment

With innovative diesel particulate filters and the nontoxic AdBlue® reducing agent, we help eliminate up to 95% of diesel NO_x emissions.

up to
31%
better efficiency

↑ ↑

Increased fuel efficiency

Another way diesel creates fewer emissions is that it gets better mileage, up to 31% more mpg than comparable gasoline engines, in fact.⁵

There is more information on the TDI® clean diesel model line in the 2015 TDI® clean diesel brochure. For details, see your dealer, go to audiusa.com or download the digital brochure from the Audi library app.

¹ 15.3% fewer CO₂ emissions based on 2014 EPA emissions data versus its comparable gasoline powered model. See www.fueleconomy.gov for details. Your vehicle emissions will vary and depends on several factors, including your driving habits and vehicle condition. ² Always obey all speed and traffic laws. ³ EPA estimates. Your mileage will vary and depends on several factors, including your driving habits and vehicle condition. See www.fueleconomy.gov for details. ⁴ 24 city/38 highway mpg (2015 A6 3.0-liter TDI® clean diesel V6 with eight-speed Tiptronic® automatic transmission and quattro® all-wheel drive). 2015 EPA estimates. Range based on EPA estimates of 38 mpg highway and a 19.2-gallon fuel tank. Your mileage will vary and depends on several factors, including your driving habits and vehicle condition. ⁵ 31% better mileage over comparable gasoline engines is based on 2015 A6 TDI® model's 29 combined mpg as rated by the EPA vs. the 2014 EPA-rated gasoline-powered equivalent. Your mileage will vary and depends on several factors, including your driving habits and vehicle condition.



Driver Assistance

We're solving problems before you even know you have them.

A little insight into the things you cannot see.

Audi strives to constantly up the ante on the driver assistance tools built right into the Audi A6, and they're all designed to work in tandem with you, wherever you go. Whether it's available advanced technologies like night vision assistant that uses infrared technology to spot pedestrians, or radar sensors that Audi side assist utilizes to inform you of vehicles approaching from the side and rear, you'll find that we've developed them to work together to help keep you aware of your surroundings. The whole suite of available driver assistance features can be found in the A6. It's another testament to the effort Audi puts into helping ensure that you're not the only one keeping an eye on the road.

Audi adaptive cruise control with stop & go

Using long range radar and a camera, the available Audi adaptive cruise control with stop & go not only helps retain a preset distance from vehicles ahead, but resumes acceleration when you're ready. It can even bring the vehicle to a full stop before accelerating when traffic flow resumes.

Audi pre sense® plus

The available Audi pre sense plus offers comprehensive driving assistance with sensors in the front, side and rear. After visual, physical and aural collision warnings, there are four distinct phases for automatic preparation for the unavoidable: an upsurge of brake pressure, safety belt pre-tensioning, partial braking, and sunroof and window preparation. In severe cases, Audi pre sense plus will engage full braking and deceleration.

Audi active lane assist

Operating at speeds above 38 mph, this available system helps detect when the vehicle begins to leave the lane without signaling. Then, through gentle, corrective steering efforts, it helps the vehicle remain in the lane and vibrates the steering wheel as an additional warning. This way, Audi active lane assist complements the driver's decision-making process and further solidifies the bond between driver and machine.



Top and corner view cameras

Four cameras on this available technology allow for an overhead view of your surroundings, making parking just a little easier. The technology shows you where your vehicle is in relation to obstacles nearby, helping give you the confidence to maneuver in practically any environment.



Night vision assistant

Using infrared technology to detect what lies ahead, this available feature uses thermal-imaging technology to help you detect trouble. Pedestrians can be detected over 300 feet in front of the vehicle, while objects can be detected over 900 feet ahead—all shown on the 7" color driver information system.



Head-up display

With easy-to-view, accurate visual information right at eye level, this available feature displays important driving information and even pedestrian-detection warnings when equipped with the optional night vision assistant.

The available **Audi side assist** uses radar sensors and two different optical warnings to help keep the driver informed about what is approaching from hard-to-see angles behind and to the side of the vehicle.

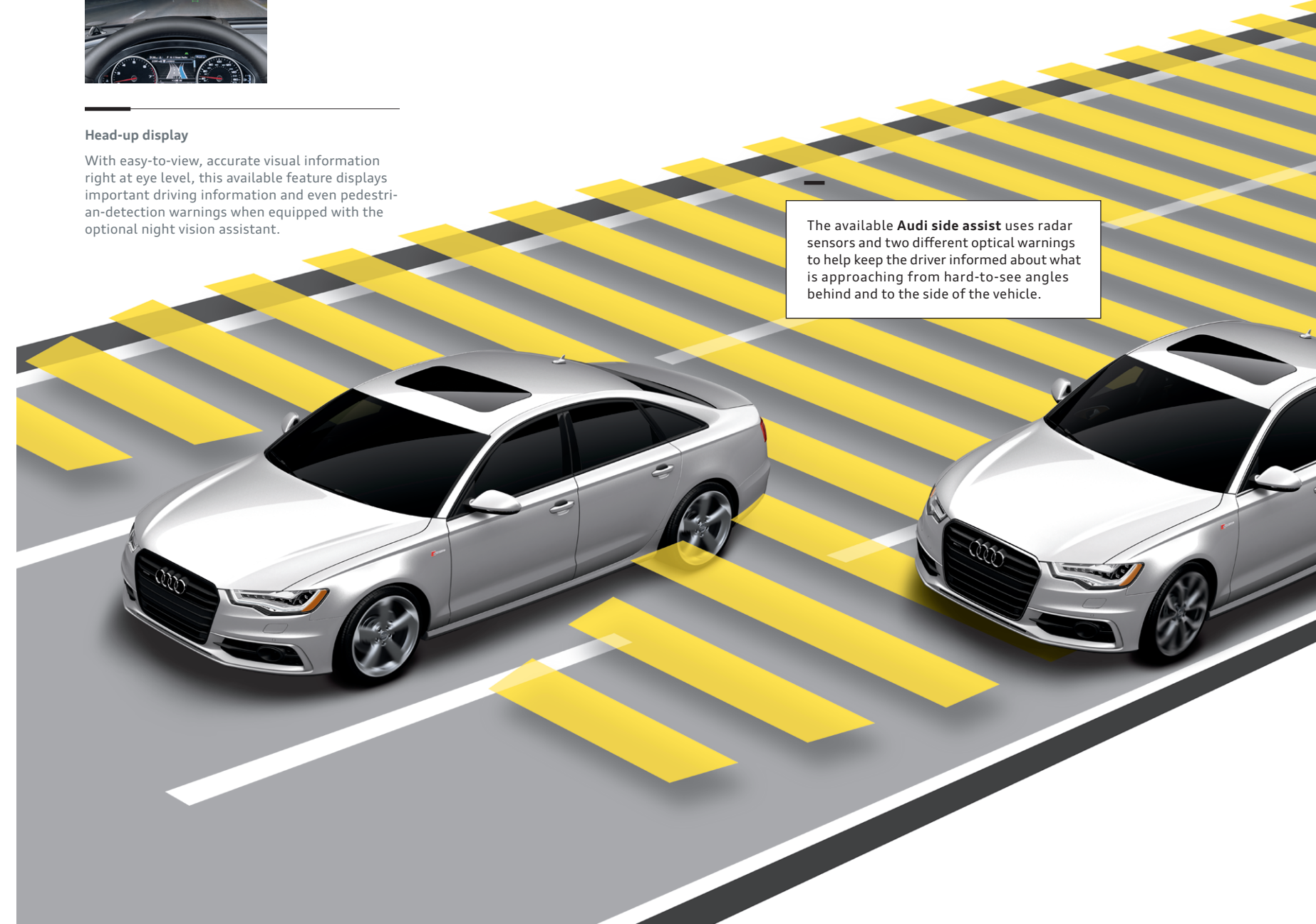

A little give requires a lot of strength.

Audi engineers don't equate strength with size. Big is just big—strong is a more flexible concept. While you may not think about weight savings when it comes to strength, we'd like you to take a second and think again. The aluminum hybrid construction developed by Audi engineers is a lightweight and unyielding revolutionary technology that offers an innovative approach to both weight savings and strength. Airbag technology is designed to respond differently based on seat position, and specially constructed crumple zones give way upon impact to help mitigate potential injury in a collision.¹ All of this, combined with the rigidity of laser seam-welded joints that enhance the strength of every Audi we make, helps diminish the impact of an unavoidable event.



Safety

Working to spread a “bend, don't break” philosophy.



ESC and ABS

Computerized technology that works in perfect sync with the Anti-lock Brake System (ABS), Electronic Stability Control (ESC) helps minimize any loss of stability, applying brake pressure to individual wheels and reducing throttle input to help counter oversteer or understeer when the vehicle needs it.

¹ Airbags are supplemental restraints only and will not deploy in all crash circumstances. Always use safety belts and seat children only in the rear, using restraint systems appropriate for their size and age.

Ten airbags

Strategically placed around the occupants, the option of up to ten airbags in the Audi A6 offers passive safety in the event of a collision, helping to protect the driver and passengers on all sides.¹

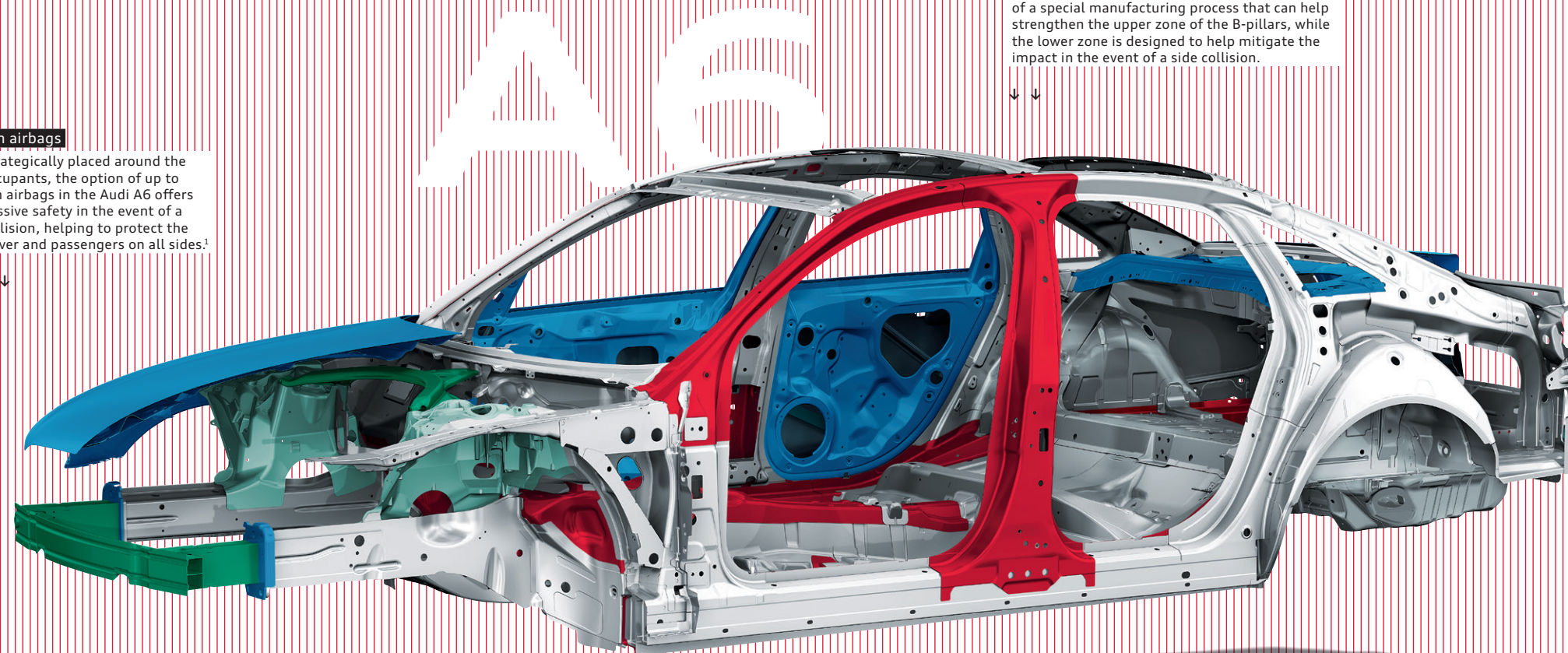

Tailor-made blanks

Developed to make the best possible use of the body's potential, tailor-made blanks are the result of a special manufacturing process that can help strengthen the upper zone of the B-pillars, while the lower zone is designed to help mitigate the impact in the event of a side collision.



Aluminum body panels

Due to their strength and the nature of their integration into the structure, aluminum body panels provide an important load-bearing function on top of cutting down on unnecessary weight.

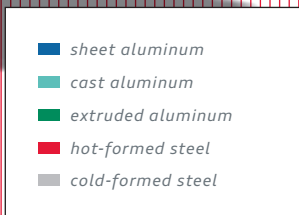



MMI System

Putting your needs front and center.

A touch of genius is simplicity itself.

A lot can be said with a simple touch. Case in point, the available MMI® touch. A revolution in intelligent simplicity, MMI touch with handwriting recognition is a technology that gives you the ability to give commands and retrieve media simply by its recognizing a few strokes of your finger. Access information such as music files, contact information and destinations through the MMI touch—or give input to the optional Audi connect®, an innovative infotainment system infused with the power of Google™ technology^{1,2} Now staying in touch with your world isn't just a good gesture, it's one simple gesture.^{1,2}

MMI touch

Developed by the Audi Human Machine Interface (HMI) team, MMI touch illustrates why making something simple to use can be so complex. The HMI team designed a system so advanced, it can read almost anyone's handwriting—even if you choose to write with your non-dominant hand.



1 2 3
4 5 6

Function buttons

Helping you navigate through the MMI system with ease are four well-placed function buttons. Each button correlates to a command at the corner of the screen and, when pressed, takes you to your desired selection.



NAV

TEL

MENU

BACK ↩

CAR

RADIO

MEDIA



SiriusXM® Satellite Radio

Go ahead. Crisscross the country. We assure you, you'll never run out of entertainment options, with over 150 channels of music, talk, sports and news.²

Audi media

The media function opens up a world of options when equipped with the MMI navigation plus, allowing you to control the Audi music interface, Secure Digital (SD) card slots, hard disk drive (HDD) audio jukebox or DVD, and BLUETOOTH® streaming audio from a compatible device.^{2,3}

MMI navigation plus

Count on the available advanced navigation system to home in on your destination with stunning precision while putting a little more depth in your journey with help from Google Earth™!¹

BLUETOOTH® wireless technology

Unlock your compatible mobile phone's potential through the MMI system. Simply pair them up and start enjoying near complete control at the touch of a button.³

¹ Always pay careful attention to the road, and do not drive while distracted. The features and technologies discussed above are optional, may require an additional subscription with separate terms and conditions, and should be used only when it is safe and appropriate. The Wi-Fi® hotspot feature is intended for passenger use only. ² See Infotainment/Technology section of the Featured Content page for important information regarding MMI® navigation plus and required SiriusXM® subscriptions. ³ Requires compatible device.

Tell us what you're looking for, and we'll deliver you to it.

Don't reach—relax. While touchscreens are seemingly everywhere, they don't need to be in your vehicle. With available Audi connect®, you may never have to reach out again.¹ Thanks to Google Voice™ Local Search, Audi connect allows you to quickly search Google™ by simple voice commands (use only when the car is stationary).¹ The crisp display is mounted farther up, closer to the windshield and near your sight line to the road ahead. For those times when you are feeling tactile, we've placed toggle buttons near the gear shifter, where your hand naturally rests when using them. So while other automobile manufacturers still want you to reach out, we've found a few ways for you to make information a lot more accessible while your hands are on the wheel.¹

POI

Point-of-interest

The point-of-interest search with voice control means that the digital world is with you on every journey.¹

myAudi

myAudi features

Plan travel from your personal computer. Send your desired destinations to your vehicle ahead of time and access your route from your vehicle later.¹

NEWS

News feeds

Stay on top of the news by having headlines and stories delivered right to your MMI® display.¹



Mobile Wi-Fi® hotspot

Provides high-speed connectivity for up to eight passenger devices through an onboard wireless hub.¹



SiriusXM® Traffic

Get traffic information overlaid onto available 3D satellite imagery to visualize a true aerial view of your route, and let the MMI navigation plus system reconfigure your route to help avoid traffic.^{1,2}



Google Earth™ with 3D satellite imagery

With Google Earth™ integration, you'll enjoy 3D satellite imagery, including Google Maps Street View, displayed right on the MMI display.¹



Weather information

Current local conditions and forecasts for your destination can help you prepare for your trip.¹



Google Voice™ Local Search

Simply tell your Audi what you are in the mood for, then let the cloud-processing power of Google™ speech recognition interpret your request and bring up a list of destinations in the area of your choice.¹



Google Maps Street View

With Google Maps Street View, your vehicle can show you a driver's-eye view of your destination right before you arrive so it's easy to recognize.¹



Parking information

Search for parking in your area of interest, check space availability and set your selection as a destination to help navigate directly to the garage entrance.^{1,3}



City events

Get information about current events, exciting locations and places of interest at your travel destination, current location or other chosen location instantly.¹



Travel info

Discover local landmarks in your area of interest, set them as your destinations, and let your vehicle lead the way as you explore the world around you.¹

¹ Always pay careful attention to the road, and do not drive while distracted. The features and technologies discussed above are optional, may require an additional subscription with separate terms and conditions, and should be used only when it is safe and appropriate. The Wi-Fi® hotspot feature is intended for passenger use only. ² See Infotainment/Technology section of the Featured Content page for important information regarding MMI® navigation plus and required SiriusXM® subscriptions. ³ Parking feature is not available everywhere and requires participation by parking provider.



Sound

Audi is Latin for "listen," so you know we take sound very seriously.

52 Hz

Low note on a kick drum

True bass tones are something you feel more than hear, and when a kick drum hits you with a frequency of 52 Hz, you definitely feel it. Knowing this, Audi sound engineers worked to reproduce sounds at this level for an exceptionally realistic experience.

2,093 Hz

High note on a piano

Even at a frequency of 2,093 Hz, the equivalent of the double high C note found on a piano, the sound system clearly and effortlessly reproduces the sound, giving you front row seats to every symphony.

261 Hz

Singing middle C

At a frequency of around 261 Hz, you'll find middle C. It is around this frequency that much of the brilliantly orchestrated sound is reproduced by the numerous, strategically placed speakers.

Lend us your ear.

It's been said that people only hear what they want to. That what they don't like just goes in one ear and out the other. Well, for those people and everyone else, we offer two sound systems that make every note worthy of your eardrum's full attention. From perfectly sculpted high notes to a crystal clear mid-range to deep-diving lows, the available BOSE® and Bang and Olufsen® sound systems are a veritable orchestra of engineering that fills the cabin with faithfully rendered, thrilling sound. So whether you're the type that wants to be soothed by sound or the type that wants to be inspired by it, we promise, if you take a moment to listen, that what you'll hear will be utterly impossible to ignore.

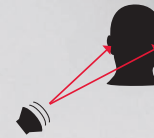

Unlike with high-frequency sounds, the brain cannot detect where low bass frequencies are coming from, making it seem as if the sound is hitting both ears at the same time. Because of this, Bang & Olufsen® sound engineers only had to design one custom-fitted subwoofer to reproduce the kind of deep, cabin-filling bass that brings music to life.



Bang & Olufsen® Advanced Sound System

The passion of Bang & Olufsen® matches well with Audi. Just consider the remarkable available Bang & Olufsen® Advanced Sound System. By focusing on design and performance together, it has become the symbol of acoustic perfection. Bang & Olufsen® engineers help to craft meticulously rendered sound through 15 speakers (including two innovative retractable aluminum acoustic lenses) and an impressive 1,300 watts through the sealed speaker cabinets and ICEpower® amp. The result: sound as captivating to your ears as an Audi is on your eyes.

BOSE® Surround Sound System

Hitting the right note on every drive, the available BOSE® Surround Sound System turns your Audi into a 14-speaker powerhouse with the help of innovative sound engineering and optimized speaker placement. Add to that AudioPilot® noise compensation, which helps maintain a consistent volume under varying speeds and road conditions, and you get an acoustic listening environment that rivals any live performance.



LED taillights

LEDs are among the most luminous taillights available. And, like Audi vehicles, they are efficient, technologically advanced and long-lasting.

You'll want to politely wave when you pass them by.

It feels good to give, so why not make a grand offering for every person you glide past in your Audi A6. Known for our stylish, signature headlights, Audi also takes pride in how we say farewell to others with our stunning LED taillights. Not only will you leave every straggler pining for more, when they disappear in your rear view mirror, you'll be left with much more than just a feeling of goodwill: a sense of pride knowing that you are at the leading edge of the automobile's twenty-first century glory days.¹

¹ Always obey all speed and traffic laws.

2.0T Premium

A6 2.0T Premium featured highlights

- ▶ Xenon plus headlights with LED daytime running lights
- ▶ Automatic headlights
- ▶ LED taillights and rear fog lights
- ▶ Power-adjustable, auto-dimming, heated exterior side mirrors with memory
- ▶ LED turn indicator lights integrated into the exterior side mirrors
- ▶ Aluminum trim around exterior windows
- ▶ Dual exhaust outlets
- ▶ Three-zone automatic climate control
- ▶ Three-spoke multifunction steering wheel with shift paddles
- ▶ Tilt and telescopic manually adjustable steering column
- ▶ Auto-dimming interior rear view mirror
- ▶ Leather-wrapped shift knob
- ▶ Aluminum door sill inlays
- ▶ Power windows with one-touch up/down operation and pinch protection
- ▶ Sunroof
- ▶ Leather seating surfaces
- ▶ Eight-way power front seats and four-way power lumbar adjustment for driver
- ▶ Driver seat memory
- ▶ Heated front seats
- ▶ Split folding 60/40 rear seatbacks
- ▶ 5" driver information system
- ▶ MMI® radio plus with ten speakers and single CD player with MP3 playback capability
- ▶ SiriusXM® Satellite Radio with 90-day trial subscription¹
- ▶ SD card slot with 32GB operating capacity (dual slots)
- ▶ Audi music interface with iPod® integration
- ▶ BLUETOOTH® wireless technology preparation for mobile phone²
- ▶ Audi pre sense® basic
- ▶ Garage door opener (HomeLink®)
- ▶ Cruise control with coast, resume and accelerate features
- ▶ Audi drive select
- ▶ Rain/light sensor for automatic windshield wipers and headlights

Available packages and stand-alone options

- ▶ Cold Weather package
- ▶ 19" Sport package
- ▶ MMI® navigation plus package³
- ▶ Rear-passenger thorax side airbags⁴
- ▶ Fine Grain Ash Natural Brown Wood decorative inlays
- ▶ Black cloth headliner (with Black or Nougat Brown leather)



Three-spoke multifunction steering wheel with shift paddles and 5" driver information system



Xenon plus headlights with LED daytime running lights



LED taillights and rear fog lights



Dark Brown Walnut Wood decorative inlays



Driver seat memory



Leather seating surfaces



MMI® interface with six radio station keys



Three-zone automatic climate control and heated front seats



18" 5-V-spoke design wheels with 245/45 all-season tires⁵



¹ SiriusXM Satellite Radio and SiriusXM Traffic subscriptions are sold separately or as a package after trial period and are continuous until you call SiriusXM to cancel. See Customer Agreement for complete terms and more information at www.siriusxm.com. SiriusXM Traffic service available in select markets. SiriusXM U.S. Satellite Service available only to those in the 48 contiguous U.S.A., D.C. and Puerto Rico (with coverage limitations). ² Requires compatible device. ³ MMI® navigation plus depends on signals from the worldwide Global Positioning Satellite network. The vehicle's electrical system and existing wireless and satellite technologies must be available and operating properly for the system to function. The system is designed to provide you with suggested routes in locating addresses, destinations and other points of interest. Changes in street names, construction zones, traffic flow, points of interest and other road system changes are beyond the control of Audi of America, Inc. Complete detailed mapping of lanes, roads, streets, toll roads, highways, etc., is not possible, therefore you may encounter discrepancies between the mapping and your actual location. Please rely on your individual judgment in determining whether or not to follow a suggested MMI® navigation plus route. For mapping updates please see your Audi dealer or call 1-800-FOR-AUDI for details. ⁴ Airbags are supplemental restraints only and will not deploy in all crash circumstances. Always use safety belts and seat children only in the rear, using restraint systems appropriate for their size and age. ⁵ High-performance tires are designed for better performance and handling in warm climates. When driving in cold, snowy or icy weather, you should equip your vehicle with four all-season or winter tires, which offer better traction under those conditions. We suggest you use the Audi-recommended winter or all-season tires specified for your Audi. High-performance tires also have a lower aspect ratio that aids performance and handling. Driving over rough or damaged road surfaces, as well as debris, curbs and other obstacles, can cause serious damage to wheels, tires, vehicle body and suspension parts. Be careful to avoid road hazards and reduce your speed, especially if your vehicle is equipped with low-profile tires. Please also remember when making your selection that, while these tires deliver responsive handling, they may ride less comfortably and make more noise than others. Finally, these tires may wear more quickly than other choices. It is important that the inflation pressure is regularly checked and maintained at recommended levels.

2.0T Premium Plus

The following highlighted features of the A6 2.0T Premium Plus add to or replace the highlighted features of the A6 2.0T Premium

- ▶ Power-adjustable, power-folding, auto-dimming, heated exterior side mirrors with memory
- ▶ MMI® navigation plus with voice control system¹
- ▶ MMI® touch with handwriting-recognition technology
- ▶ Audi connect® with six-month trial subscription²
- ▶ 7" color driver information system
- ▶ HD Radio™ Technology
- ▶ SiriusXM® Traffic with four-year subscription³
- ▶ BLUETOOTH® streaming audio⁴
- ▶ Audi advanced key—keyless start, stop and entry⁵
- ▶ Audi side assist with Audi pre sense® rear
- ▶ Parking system plus with rear view camera (front and rear acoustic parking sensors)

Available packages and stand-alone options

- ▶ Cold Weather package
- ▶ Warm Weather package
- ▶ 19" Sport package
- ▶ 20" Sport package
- ▶ Rear-passenger thorax side airbags⁶
- ▶ BOSE® Surround Sound System with 14 speakers, AudioPilot® noise-compensation and 630 watts
- ▶ Fine Grain Ash Natural Brown Wood decorative inlays
- ▶ Black cloth headliner (with Black or Nougat Brown leather)



Three-spoke multifunction steering wheel with shift paddles and 7" color driver information system



Audi advanced key—keyless start, stop and entry⁵ Power-folding exterior side mirrors



Dark Brown Walnut Wood decorative inlays



Audi side assist and Audi pre sense® rear



MMI® navigation plus with 8" retractable display¹



MMI® touch with handwriting-recognition technology and Audi connect®²

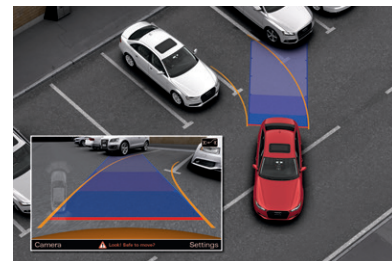

Parking system plus with rear view camera (front and rear acoustic parking sensors)



18" 5-V-spoke design wheels with 245/45 all-season tires⁷



¹ MMI® navigation plus depends on signals from the worldwide Global Positioning Satellite network. The vehicle's electrical system and existing wireless and satellite technologies must be available and operating properly for the system to function. The system is designed to provide you with suggested routes in locating addresses, destinations and other points of interest. Changes in street names, construction zones, traffic flow, points of interest and other road system changes are beyond the control of Audi of America, Inc. Complete detailed mapping of lanes, roads, streets, toll roads, highways, etc., is not possible, therefore you may encounter discrepancies between the mapping and your actual location. Please rely on your individual judgment in determining whether or not to follow a suggested MMI® navigation plus route. For mapping updates please see your Audi dealer or call 1-800-FOR-AUDI for details. ² Always pay careful attention to the road, and do not drive while distracted. The features and technologies discussed above are optional, may require an additional subscription with separate terms and conditions, and should be used only when it is safe and appropriate. The Wi-Fi® hotspot feature is intended for passenger use only. ³ SiriusXM Satellite Radio and SiriusXM Traffic subscriptions are sold separately or as a package after trial period and are continuous until you call SiriusXM to cancel. See Customer Agreement for complete terms and more information at www.siriusxm.com. SiriusXM Traffic service available in select markets. SiriusXM U.S. Satellite Service available only to those in the 48 contiguous U.S.A., D.C. and Puerto Rico (with coverage limitations). ⁴ Requires compatible device. ⁵ Some Audi models are equipped with a keyless ignition feature. The details as to how the system works can vary, and Audi owners should consult their owner's literature or an authorized Audi dealer if they have further questions about the operation of this feature. Please note that Audi warns against leaving the vehicle unattended with the engine running, particularly in enclosed spaces. ⁶ Airbags are supplemental restraints only and will not deploy in all crash circumstances. Always use safety belts and seat children only in the rear, using restraint systems appropriate for their size and age. ⁷ High-performance tires are designed for better performance and handling in warm climates. When driving in cold, snowy or icy weather, you should equip your vehicle with four all-season or winter tires, which offer better traction under those conditions. We suggest you use the Audi-recommended winter or all-season tires specified for your Audi. High-performance tires also have a lower aspect ratio that aids performance and handling. Driving over rough or damaged road surfaces, as well as debris, curbs and other obstacles, can cause serious damage to wheels, tires, vehicle body and suspension parts. Be careful to avoid road hazards and reduce your speed, especially if your vehicle is equipped with low-profile tires. Please also remember when making your selection that, while these tires deliver responsive handling, they may ride less comfortably and make more noise than others. Finally, these tires may wear more quickly than other choices. It is important that the inflation pressure is regularly checked and maintained at recommended levels.

3.0T/TDI® Premium Plus

The following highlighted features of the A6 3.0T and TDI® Premium Plus add to or replace the highlighted features of the A6 2.0T Premium Plus

- ▶ Power-adjustable, power-folding, auto-dimming, heated exterior side mirrors with memory
- ▶ S line® exterior appearance
- ▶ MMI® navigation plus with voice control system¹
- ▶ MMI® touch with handwriting-recognition technology
- ▶ Audi connect® with six-month trial subscription²
- ▶ 7" color driver information system
- ▶ HD Radio™ Technology
- ▶ SiriusXM® Traffic with four-year subscription³
- ▶ BLUETOOTH® streaming audio⁴
- ▶ Audi advanced key—keyless start, stop and entry⁵
- ▶ Audi side assist with Audi pre sense® rear
- ▶ Parking system plus with rear view camera (front and rear acoustic parking sensors)

Available packages and stand-alone options

- ▶ Cold Weather package
- ▶ Warm Weather package
- ▶ Driver Assistance package
- ▶ 19" Sport package
- ▶ 20" Sport package
- ▶ Full LED headlights
- ▶ Rear-passenger thorax side airbags⁶
- ▶ BOSE® Surround Sound System with 14 speakers, AudioPilot® noise-compensation and 630 watts
- ▶ Fine Grain Ash Natural Brown Wood decorative inlays
- ▶ Black cloth headliner (with Black or Nougat Brown leather)



Three-spoke multifunction steering wheel with shift paddles and 7" color driver information system



S line® exterior appearance—front fascia



S line® exterior appearance—rear diffuser



Dark Brown Walnut Wood decorative inlays



Audi side assist and Audi pre sense® rear



MMI® navigation plus with 8" retractable display¹



MMI® touch with handwriting-recognition technology and Audi connect®²

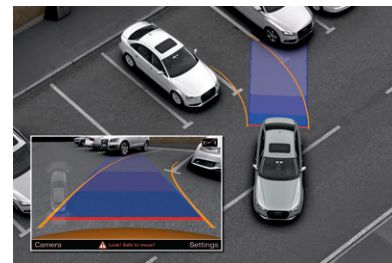

Parking system plus with rear view camera (front and rear acoustic parking sensors)



18" 5-V-spoke design wheels with 245/45 all-season tires⁷



¹ MMI® navigation plus depends on signals from the worldwide Global Positioning Satellite network. The vehicle's electrical system and existing wireless and satellite technologies must be available and operating properly for the system to function. The system is designed to provide you with suggested routes in locating addresses, destinations and other points of interest. Changes in street names, construction zones, traffic flow, points of interest and other road system changes are beyond the control of Audi of America, Inc. Complete detailed mapping of lanes, roads, streets, toll roads, highways, etc., is not possible, therefore you may encounter discrepancies between the mapping and your actual location. Please rely on your individual judgment in determining whether or not to follow a suggested MMI® navigation plus route. For mapping updates please see your Audi dealer or call 1-800-FOR-AUDI for details. ² Always pay careful attention to the road, and do not drive while distracted. The features and technologies discussed above are optional, may require an additional subscription with separate terms and conditions, and should be used only when it is safe and appropriate. The Wi-Fi® hotspot feature is intended for passenger use only. ³ SiriusXM Satellite Radio and SiriusXM Traffic subscriptions are sold separately or as a package after trial period and are continuous until you call SiriusXM to cancel. See Customer Agreement for complete terms and more information at www.siriusxm.com. SiriusXM Traffic service available in select markets. SiriusXM U.S. Satellite Service available only to those in the 48 contiguous U.S.A., D.C. and Puerto Rico (with coverage limitations). ⁴ Requires compatible device. ⁵ Some Audi models are equipped with a keyless ignition feature. The details as to how the system works can vary, and Audi owners should consult their owner's literature or an authorized Audi dealer if they have further questions about the operation of this feature. Please note that Audi warns against leaving the vehicle unattended with the engine running, particularly in enclosed spaces. ⁶ Airbags are supplemental restraints only and will not deploy in all crash circumstances. Always use safety belts and seat children only in the rear, using restraint systems appropriate for their size and age. ⁷ High-performance tires are designed for better performance and handling in warm climates. When driving in cold, snowy or icy weather, you should equip your vehicle with four all-season or winter tires, which offer better traction under those conditions. We suggest you use the Audi-recommended winter or all-season tires specified for your Audi. High-performance tires also have a lower aspect ratio that aids performance and handling. Driving over rough or damaged road surfaces, as well as debris, curbs and other obstacles, can cause serious damage to wheels, tires, vehicle body and suspension parts. Be careful to avoid road hazards and reduce your speed, especially if your vehicle is equipped with low-profile tires. Please also remember when making your selection that, while these tires deliver responsive handling, they may ride less comfortably and make more noise than others. Finally, these tires may wear more quickly than other choices. It is important that the inflation pressure is regularly checked and maintained at recommended levels.

3.0T/TDI® Prestige

The following highlighted features of the A6 3.0T and TDI® Prestige add to or replace the highlighted features of the A6 3.0T and TDI® Premium Plus

- ▶ Full LED headlights
- ▶ Four-zone automatic climate control
- ▶ Power tilt and telescopic adjustable steering column
- ▶ Manual rear-side window and power rear window sunshades
- ▶ Ambient LED interior lighting
- ▶ Twelve-way power front seats, including four-way power lumbar adjustment
- ▶ Ventilated front seats
- ▶ BOSE® Surround Sound System with 14 speakers, AudioPilot® noise-compensation and 630 watts
- ▶ Head-up display with navigation information

Available packages and stand-alone options

- ▶ Cold Weather package
- ▶ Driver Assistance package
- ▶ Black Optic package
- ▶ 19" Sport package
- ▶ 20" Sport package
- ▶ Bang & Olufsen® Advanced Sound System with 15 speakers and 1,300 watts
- ▶ Night vision assistant with pedestrian detection
- ▶ Rear-passenger thorax side airbags¹
- ▶ Fine Grain Ash Natural Brown Wood decorative inlays
- ▶ Black cloth headliner (with Black or Nougat Brown leather)



Perforated leather seating surfaces



Three-spoke multifunction steering wheel with shift paddles, 7" color driver information system and head-up display



Four-zone automatic climate control



Manual rear-side window and power rear window sunshades



Dark Brown Walnut Wood decorative inlays



BOSE® Surround Sound System with 14 speakers, AudioPilot® noise-compensation and 630 watts



Ambient LED interior lighting



Full LED headlights



Ventilated front seats



18" 5-V-spoke design wheels with 245/45 all-season tires²



¹ Airbags are supplemental restraints only and will not deploy in all crash circumstances. Always use safety belts and seat children only in the rear, using restraint systems appropriate for their size and age. ² High-performance tires are designed for better performance and handling in warm climates. When driving in cold, snowy or icy weather, you should equip your vehicle with four all-season or winter tires, which offer better traction under those conditions. We suggest you use the Audi-recommended winter or all-season tires specified for your Audi. High-performance tires also have a lower aspect ratio that aids performance and handling. Driving over rough or damaged road surfaces, as well as debris, curbs and other obstacles, can cause serious damage to wheels, tires, vehicle body and suspension parts. Be careful to avoid road hazards and reduce your speed, especially if your vehicle is equipped with low-profile tires. Please also remember when making your selection that, while these tires deliver responsive handling, they may ride less comfortably and make more noise than others. Finally, these tires may wear more quickly than other choices. It is important that the inflation pressure is regularly checked and maintained at recommended levels.

Packages

Analogous to the progressive nature in which all our vehicles are engineered are the technologies and offerings available in a variety of packages to enhance the experience of driving an Audi vehicle. To prove that luxury has progressed, we invite you to explore the package that best outfits your Audi A6.

19" Sport package

Available on all models:

- ▶ 19" 5-double-spoke design wheels
- ▶ 255/40 all-season tires¹
- ▶ Sport suspension calibration

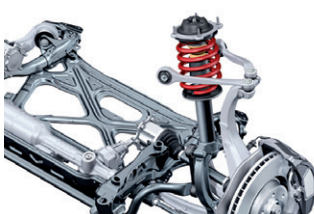

20" Sport package

Available on Premium Plus and Prestige models:

- ▶ 20" 10-spoke V design wheels
- ▶ 255/35 summer performance tires¹
- ▶ Sport suspension calibration

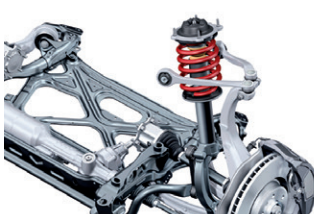

Black Optic package

Available on Prestige models:

- ▶ 20" 5-arm-rotor design wheels (Titanium finish)
- ▶ 255/35 summer performance tires¹
- ▶ Gloss Black Singleframe® grille
- ▶ Gloss Black trim around exterior windows



Driver Assistance package

Available on Premium Plus and Prestige (3.0T and TDI® models only):

- ▶ Audi adaptive cruise control with stop & go
- ▶ Audi active lane assist
- ▶ Audi pre sense® plus
- ▶ Top and corner view camera system



MMI® navigation plus package

Available on Premium models:

- ▶ MMI® navigation plus with voice control system²
- ▶ MMI® touch with handwriting-recognition technology
- ▶ Audi connect® with six-month trial subscription³
- ▶ 7" color driver information system
- ▶ HD Radio™ Technology
- ▶ SiriusXM® Traffic with four-year subscription⁴
- ▶ BLUETOOTH® streaming audio⁵



Cold Weather package

Available on Premium, Premium Plus and Prestige models:

- ▶ Heated steering wheel
- ▶ Heated rear seats



Warm Weather package

Available on Premium Plus models:

- ▶ Four-zone automatic climate control
- ▶ Manual rear-side window and power rear window sunshades



¹ High-performance tires are designed for better performance and handling in warm climates. When driving in cold, snowy or icy weather, you should equip your vehicle with four all-season or winter tires, which offer better traction under those conditions. We suggest you use the Audi-recommended winter or all-season tires specified for your Audi. High-performance tires also have a lower aspect ratio that aids performance and handling. Driving over rough or damaged road surfaces, as well as debris, curbs and other obstacles, can cause serious damage to wheels, tires, vehicle body and suspension parts. Be careful to avoid road hazards and reduce your speed, especially if your vehicle is equipped with low-profile tires. Please also remember when making your selection that, while these tires deliver responsive handling, they may ride less comfortably and make more noise than others. Finally, these tires may wear more quickly than other choices. It is important that the inflation pressure is regularly checked and maintained at recommended levels. ² MMI® navigation plus depends on signals from the worldwide Global Positioning Satellite network. The vehicle's electrical system and existing wireless and satellite technologies must be available and operating properly for the system to function. The system is designed to provide you with suggested routes in locating addresses, destinations and other points of interest. Changes in street names, construction zones, traffic flow, points of interest and other road system changes are beyond the control of Audi of America, Inc. Complete detailed mapping of lanes, roads, streets, toll roads, highways, etc., is not possible, therefore you may encounter discrepancies between the mapping and your actual location. Please rely on your individual judgment in determining whether or not to follow a suggested MMI® navigation plus route. For mapping updates please see your Audi dealer or call 1-800-FOR-AUDI for details. ³ Always pay careful attention to the road, and do not drive while distracted. The features and technologies discussed above are optional, may require an additional subscription with separate terms and conditions, and should be used only when it is safe and appropriate. The Wi-Fi® hotspot feature is intended for passenger use only. ⁴ SiriusXM Satellite Radio and SiriusXM Traffic subscriptions are sold separately or as a package after trial period and are continuous until you call SiriusXM to cancel. See Customer Agreement for complete terms and more information at www.siriusxm.com. SiriusXM Traffic service available in select markets. SiriusXM U.S. Satellite Service available only to those in the 48 contiguous U.S.A., D.C. and Puerto Rico (with coverage limitations). ⁵ Requires compatible device.

Options

In addition to the many packages available for your Audi A6, there are also a host of a la carte options to outfit your vehicle. From choices of elegant interior trims to features like rear-passenger side thorax airbags and full LED headlights, there's an option to help better complement your lifestyle.¹



BOSE® Surround Sound System with 14 speakers, AudioPilot® noise-compensation and 630 watts
(optional on Premium Plus models)



Bang and Olufsen® Advanced Sound System
(optional on Prestige models)



Night vision assistant with pedestrian detection
(optional on Prestige models)



Fine Grain Ash Natural Brown Wood decorative inlays
(optional on all models)



Rear-passenger thorax side airbags¹
(optional on all models)



Full LED headlights
(optional on 3.0T/TDI® Premium Plus models)



Black cloth headliner
(optional on all models)

¹ Airbags are supplemental restraints only and will not deploy in all crash circumstances. Always use safety belts and seat children only in the rear, using restraint systems appropriate for their size and age.

Exterior Colors

Brilliant Black

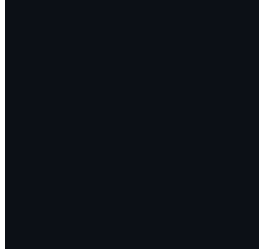

Ibis White

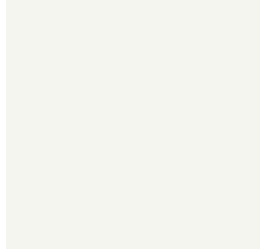

Aviator Blue metallic

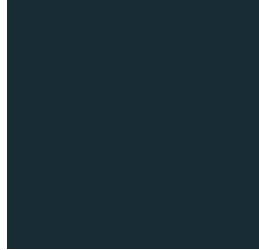

Dakota Gray metallic

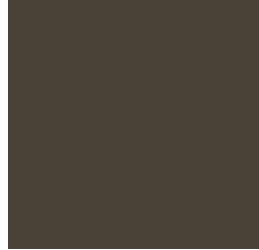

Glacier White metallic

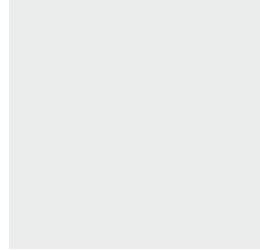

Havana Black metallic

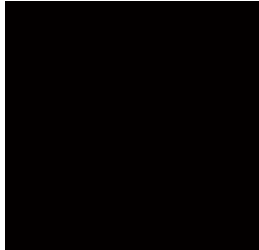

Ice Silver metallic



Moonlight Blue metallic



Oolong Gray metallic



Quartz Gray metallic



Daytona Gray pearl

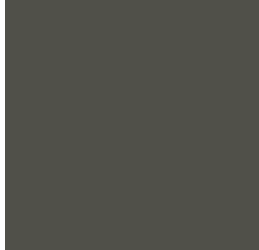

Garnet Red pearl



Phantom Black pearl

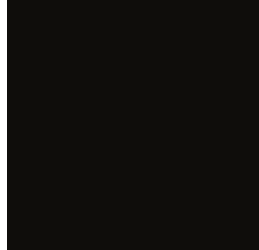

Prestige models only

Exterior colors, interior colors and decorative inlay options will vary based on model and trim level combination. See your dealer for details.

Seat Selections | Interior Colors

Standard Seat



Comfort Seat¹



Black leather

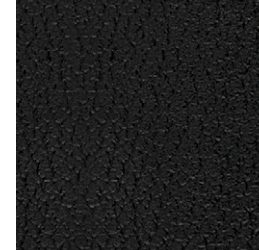

Standard

Nougat Brown leather



Standard

Titanium Gray leather

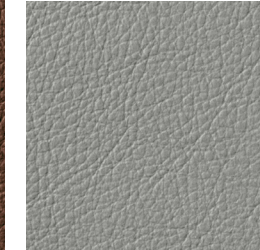

Standard

Velvet Beige leather



Standard

Black perforated leather

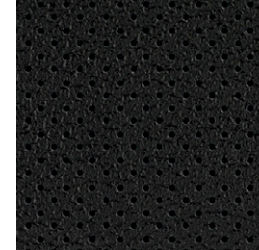

Comfort

Nougat Brown perforated leather

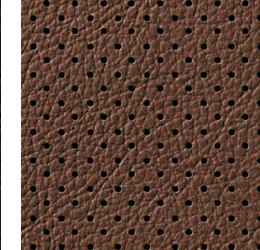

Comfort

Titanium Gray perforated leather

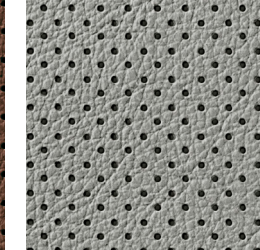

Comfort

Velvet Beige perforated leather

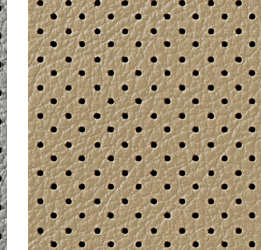

Comfort

¹ Standard on Prestige models.

Technical Specifications

| Engineering Performance | A6 2.0T | A6 3.0T | A6 TDI® |
|---|-------------------------------------|--|--------------------------|
| Engine type | Four-cylinder | Six-cylinder | Six-cylinder |
| Engine block/Cylinder head | Cast-iron/Aluminum-alloy | Aluminum-alloy | Cast-iron/Aluminum-alloy |
| Displacement (cc)/Bore and stroke (mm) | 1,984/82.5 x 92.8 | 2,995/84.5 x 89.0 | 2,967/83.0 x 91.4 |
| Horsepower (@ rpm) | 220 @ 4,450–6,000 | 310 @ 5,500–6,500 | 240 @ 3,500–3,750 |
| Torque (lb-ft @ rpm) | 258 @ 1,500–4,300 | 325 @ 2,900–4,500 | 428 @ 1,750–2,250 |
| Compression ratio | 9.6:1 | 10.3:1 | 16.8:1 |
| Valvetrain | 16-valve DOHC with valvelift system | 24-valve DOHC with variable valve timing | 24-valve DOHC |
| Induction/Fuel injection | Turbocharged/TFSI® | Supercharged/TFSI® | Turbocharged/TDI® |
| Start-stop efficiency system | — | ■ | ■ |
| Acceleration with multitronic®/Tiptronic® transmission (0–60 mph) | 7.4/6.6 seconds | —/5.3 seconds | —/5.5 seconds |
| Top track speed ¹ | 130 mph | 130 mph | 130 mph |

Transmission | Drivetrain

| | | | |
|--|-----------|---|---|
| multitronic® continuously variable transmission with front-wheel drive (Gear ratios: 1st: 3.829, 2nd: 1.686, 3rd: 1.241, 4th: 0.960, 5th: 0.760, 6th: 0.605, 7th: 0.481, 8th: 0.608, Reverse: 4.633, Final drive: 3.091) | ■ | — | — |
| Eight-speed Tiptronic® automatic transmission with quattro® all-wheel drive (Gear ratios: 1st: 4.714, 2nd: 3.143, 3rd: 2.106, 4th: 1.667, 5th: 1.285, 6th: 1.000, 7th: 0.839, 8th: 0.667, Reverse: 3.317, Final drive: 3.076 for 2.0T models, 2.848 for 3.0T models, 2.519 for TDI® models) | Available | ■ | ■ |

Body | Suspension | Chassis

| | | | |
|---|-----------|-----------|-----------|
| ultra® lightweight technology—aluminum exterior body panels and a steel chassis | ■ | ■ | ■ |
| Five-link front suspension | ■ | ■ | ■ |
| Trapezoidal-link rear suspension | ■ | ■ | ■ |
| Sport suspension calibration | Available | Available | Available |
| Ventilated front disc/Ventilated rear disc brakes (in) | 13.6/13.0 | 14.0/13.0 | 13.6/13.0 |
| Electromechanical power steering system | ■ | ■ | ■ |
| Steering ratio | 16.1:1 | 16.1:1 | 16.1:1 |
| Turning diameter, curb-to-curb (ft) | 39.0 | 39.0 | 39.0 |

■ Standard — Not applicable NA Information not available at time of printing

| Exterior measurements | A6 2.0T | A6 3.0T | A6 TDI® |
|---|-----------|-----------|-----------|
| Wheelbase (in) | 114.7 | 114.7 | 114.7 |
| Length (in) | 193.9 | 193.9 | 193.9 |
| Height (in) | 57.8 | 57.8 | 57.8 |
| Overall width with mirrors (in) | 82.1 | 82.1 | 82.1 |
| Overall width without mirrors (in) | 73.8 | 73.8 | 73.8 |
| Track front/rear (in) | 64.1/63.7 | 64.1/63.7 | 64.1/63.7 |
| Curb weight with multitronic® transmission (lb) | 3,726 | — | — |
| Curb weight with Tiptronic® transmission (lb) | 3,957 | 4,101 | 4,178 |
| Drag coefficient (C _w) | .26 | .28 | .28 |

Interior measurements

| | | | |
|---|-----------|-----------|-----------|
| Head room (in, front/rear) | 37.2/37.8 | 37.2/37.8 | 37.2/37.8 |
| Leg room (in, front/rear) | 41.3/37.4 | 41.3/37.4 | 41.3/37.4 |
| Shoulder room (in, front/rear) | 57.5/56.3 | 57.5/56.3 | 57.5/56.3 |
| Cargo volume (cu ft, rear seatbacks up) | 14.1 | 14.1 | 14.1 |
| Seating capacity | 5 | 5 | 5 |

EPA mileage estimates | Capacities | Emissions

| | | | |
|---|-----------------------|-----------------|-------------------------|
| multitronic® transmission (city/highway/combined) | 25/33/28 ² | — | — |
| Tiptronic® automatic transmission (city/highway/combined) | 20/29/23 ² | NA ³ | 24/38/29 ² |
| Engine oil (qt) | 4.9 | 7.2 | 7.2 |
| Fuel (gal) | 19.8 | 19.8 | 19.2 |
| Required fuel | Premium | Premium | Ultra-low-sulfur diesel |
| Emissions rating | ULEV II | ULEV II | ULEV II |

Audi Sport
Truth in Engineering



Technical specifications and featured content for Audi S6 models can be found in the **2015 Audi Sport brochure**. See your dealer or go to audiusa.com for details.

¹ Top track speed is electronically limited in the U.S. Always obey all speed and traffic laws. ² EPA estimates. Your mileage will vary and depends on several factors, including your driving habits and vehicle condition. See www.fueleconomy.gov for details. ³ 2015 EPA estimates and emissions data not available at time of printing. See www.fueleconomy.gov for updated information. Your mileage and emissions will vary and depend on several factors, including your driving habits and vehicle condition.

Featured Content

Safety | Security

| | 2.0T Premium | 2.0T/3.0T/TDI® Premium Plus | 3.0T/TDI® Prestige |
|---|--------------|-----------------------------|--------------------|
| Driver and front passenger dual-stage airbags, front thorax side airbags, knee airbags and Sideguard® head curtain airbags ¹ | ■ | ■ | ■ |
| Rear-passenger thorax side airbags ¹ | Available | Available | Available |
| Front-passenger occupant detection for airbags ¹ | ■ | ■ | ■ |
| Safety belt reminder for driver and front passenger | ■ | ■ | ■ |
| Lower Anchors and Tethers for CHildren (LATCH) in rear seats | ■ | ■ | ■ |
| Power central locking system with safety unlock feature if airbags deploy | ■ | ■ | ■ |
| Electronic Stability Control (ESC) with traction control (ASR) | ■ | ■ | ■ |
| Anti-lock Brake System (ABS) with Electronic Brake-pressure Distribution (EBD) and brake assist | ■ | ■ | ■ |
| Tire-pressure monitoring system | ■ | ■ | ■ |
| Electromechanical parking brake | ■ | ■ | ■ |
| Anti-theft alarm system with immobilizer | ■ | ■ | ■ |

Exterior

| | | | |
|---|---|-----------------------|-----------|
| Singleframe® grille | ■ | ■ | ■ |
| Gloss Black Singleframe® grille | — | — | Available |
| Xenon plus headlights with LED daytime running lights | ■ | ■ | — |
| Full LED headlights | — | —/Available/Available | ■ |
| Automatic headlights | ■ | ■ | ■ |
| LED taillights and rear fog lights | ■ | ■ | ■ |
| Power-adjustable, auto-dimming, heated exterior side mirrors with memory | ■ | — | — |
| Power-adjustable, power-folding, auto-dimming, heated exterior side mirrors with memory | — | ■ | ■ |
| LED turn indicator lights integrated into the exterior side mirrors | ■ | ■ | ■ |
| Heated windshield washer nozzles | ■ | ■ | ■ |
| Aluminum trim around exterior windows | ■ | ■ | ■ |
| Gloss Black trim around exterior windows | — | — | Available |
| Dual exhaust outlets | ■ | ■ | ■ |
| S line® exterior appearance | — | —/■/■ | ■ |

Interior

| | 2.0T Premium | 2.0T/3.0T/TDI® Premium Plus | 3.0T/TDI® Prestige |
|---|--------------|-----------------------------|--------------------|
| Three-zone automatic climate control | ■ | ■ | — |
| Four-zone automatic climate control | — | Available | ■ |
| Three-spoke multifunction steering wheel with shift paddles | ■ | ■ | ■ |
| Heated steering wheel | Available | Available | Available |
| Tilt and telescopic manually adjustable steering column | ■ | ■ | — |
| Power tilt and telescopic adjustable steering column | — | — | ■ |
| Auto-dimming interior rear view mirror | ■ | ■ | ■ |
| Illuminated locking glove compartment | ■ | ■ | ■ |
| Leather-wrapped shift knob | ■ | ■ | ■ |
| Four beverage holders | ■ | ■ | ■ |
| Decorative interior inlays | ■ | ■ | ■ |
| Aluminum door sill inlays | ■ | ■ | ■ |
| Ambient LED interior lighting | — | — | ■ |
| Black cloth headliner (with Black or Nougat Brown leather) | Available | Available | Available |
| Dual front sun visors with lighted vanity mirrors | ■ | ■ | ■ |
| Power windows with one-touch up/down operation and pinch protection | ■ | ■ | ■ |
| Manual rear-side window and power rear window sunshades | — | Available | ■ |
| Sunroof | ■ | ■ | ■ |

Seating

| | | | |
|---|-----------|-----------|-----------|
| Leather seating surfaces (perforated on Prestige) | ■ | ■ | ■ |
| Eight-way power front seats and four-way power lumbar adjustment for driver | ■ | ■ | — |
| Twelve-way power front seats, including four-way power lumbar adjustment | — | — | ■ |
| Driver seat memory | ■ | ■ | ■ |
| Heated front seats | ■ | ■ | ■ |
| Ventilated front seats | — | — | ■ |
| Heated rear seats | Available | Available | Available |
| Split folding 60/40 rear seatbacks | ■ | ■ | ■ |

■ Standard — Not applicable NA Information not available at time of printing

¹ Airbags are supplemental restraints only and will not deploy under all crash circumstances. Always use safety belts and seat children only in the rear, using restraint systems appropriate for their size and age.

Featured Content

Infotainment | Technology

| | 2.0T Premium | 2.0T/3.0T/TDI® Premium Plus | 3.0T/TDI® Prestige |
|--|-----------------------------|-----------------------------|--------------------|
| MMI® navigation plus with voice control system ¹ | Available | ■ | ■ |
| MMI® touch with handwriting-recognition technology | Available (with navigation) | ■ | ■ |
| Audi connect® with six-month trial subscription ² | Available (with navigation) | ■ | ■ |
| 5" driver information system | ■ | — | — |
| 7" color driver information system | Available (with navigation) | ■ | ■ |
| MMI® radio plus with ten speakers and single CD player with MP3 playback capability | ■ | ■ | — |
| BOSE® Surround Sound System with 14 speakers, AudioPilot® noise compensation and 630 watts | — | Available | ■ |
| Bang & Olufsen® Advanced Sound System with 15 speakers and 1,300 watts | — | — | Available |
| HD Radio™ Technology | Available (with navigation) | ■ | ■ |
| SiriusXM® Satellite Radio with 90-day trial subscription ³ | ■ | ■ | ■ |
| SiriusXM® Traffic with four-year subscription ³ | Available (with navigation) | ■ | ■ |
| SD card slot with 32GB operating capacity (dual slots) | ■ | ■ | ■ |
| Audi music interface with iPod® integration | ■ | ■ | ■ |
| BLUETOOTH® streaming audio ⁴ | Available (with navigation) | ■ | ■ |
| BLUETOOTH® wireless technology preparation for mobile phone ⁴ | ■ | ■ | ■ |
| Garage door opener (HomeLink®) | ■ | ■ | ■ |
| Audi advanced key—keyless start, stop and entry ⁵ | — | ■ | ■ |
| Cruise control with coast, resume and accelerate features | ■ | ■ | ■ |
| Audi adaptive cruise control with stop & go | — | —/Available/Available | Available |
| Audi active lane assist | — | —/Available/Available | Available |
| Audi side assist with Audi pre sense® rear | — | ■ | ■ |
| Audi pre sense® plus | — | —/Available/Available | Available |
| Night vision assistant with pedestrian detection | — | — | Available |
| Head-up display with navigation information | — | — | ■ |
| Audi drive select | ■ | ■ | ■ |
| Parking system plus with rear view camera (front and rear acoustic parking sensors) | — | ■ | ■ |
| Top and corner view camera system | — | —/Available/Available | Available |
| Rain/light sensor for automatic windshield wipers and headlights | ■ | ■ | ■ |

¹ MMI® navigation plus depends on signals from the worldwide Global Positioning Satellite network. The vehicle's electrical system and existing wireless and satellite technologies must be available and operating properly for the system to function. The system is designed to provide you with suggested routes in locating addresses, destinations and other points of interest. Changes in street names, construction zones, traffic flow, points of interest and other road system changes are beyond the control of Audi of America, Inc. Complete detailed mapping of lanes, roads, streets, toll roads, highways, etc., is not possible, therefore you may encounter discrepancies between the mapping and your actual location. Please rely on your individual judgment in determining whether or not to follow a suggested MMI® navigation plus route. For mapping updates please see your Audi dealer or call 1-800-FOR-AUDI for details. ² See the Audi connect® page for important information about Audi connect®. ³ SiriusXM Satellite Radio and SiriusXM Traffic subscriptions are sold separately or as a package after trial period and are continuous until you call SiriusXM to cancel. See Customer Agreement for complete terms and more information at www.siriusxm.com. SiriusXM Traffic service available in select markets. SiriusXM U.S. Satellite Service available only to those in the 48 contiguous U.S.A., D.C. and Puerto Rico (with coverage limitations). ⁴ Requires compatible device. ⁵ Some Audi models are equipped with a keyless ignition feature. The details as to how the system works can vary, and Audi owners should consult their owner's literature or an authorized Audi dealer if they have further questions about the operation of this feature. Please note that Audi warns against leaving the vehicle unattended with the engine running, particularly in enclosed spaces.

Giving black the white tie treatment.

If the A6 makes a statement, the A6 Black Optic package is an outright declaration. First off, 20" Titanium-finish 5-arm-rotor design wheels set this vehicle apart even at a standstill. Add to that a striking Black Singleframe® grille and the already muscular and sporty look provided by the Prestige model, and you'll see why some things never go out of style.



Accessories

Add distinction, versatility and the ultimate in self-expression with Audi Genuine Accessories. Whether you load the cargo carrier with climbing gear or add a set of stylish new wheels, we have the accessories that will help enhance every facet of your lifestyle. When purchased from an authorized dealer, all pieces are backed



Fork-mount bike rack

Take along your favorite bike. Made of anodized aluminum, this rack features a quick-clamping device that can be secured with the included lock.^{2,3}



Compact cargo carrier

Your gear won't take up valuable trunk space with our aerodynamic carrier that offers a generous 16.95-cu-ft capacity. Size: 81" long, 30" wide, 15" high.^{2,3}



Ski and snowboard rack

This rack transports your equipment to the slopes easily and securely. The standard attachment (shown) holds two sets of skis or two snowboards. A deluxe attachment is also available.^{2,3}

by your vehicle's 4-year/50,000-mile limited warranty or for 12 months/12,000 miles from the accessory purchase date, whichever is greater! If you're looking to personalize or protect the vehicle you love, we have an Audi-designed solution that works for you.



20" 5-tri-spoke wheels

A sporty yet elegant design in Anthracite with machine-polished spokes. Every Audi alloy wheel design is engineered, manufactured and tested to meet rigorous factory and regulatory standards—an area where other wheels often fall short.



All-weather cargo mat

Custom fit for your A6, the raised outside edge of the cargo mat helps contain spills and protect cargo-area carpeting from stains. The textured material helps control load shifting.



Load-protection film

This custom-fit transparent film helps protect the rear bumper from scratches while loading and unloading. The red outline depicts the coverage area.



Premium textile floor mats

These skid-resistant, precision-fit mats are made of long-life fabric to help protect your vehicle's interior from the elements. Mats are black and available in a set of four.



A6/S6 all-weather floor mats

Deep-ribbed, channeled design helps protect your vehicle's floor and carpeting from water, mud, sand and snow. Black mats are available in sets of two for front or rear. Front mats feature your vehicle's logo.

Other accessories

Audi Genuine Sport and Design Accessories

Your Audi vehicle features a bold, aggressive stance and strong, stunning lines. Enhance it by adding Audi Genuine Sport and Design Accessories. All are carefully scrutinized in the design and development process. So while they're striking in appearance, they've also passed rigorous quality assessments, including corrosion testing. If you're looking for a bolder appearance or a finishing touch, there is a solution designed by Audi that makes every mile more enjoyable—and more yours.

Audi Genuine Alloy Wheels

Strike the perfect balance between breathtaking design and awe-inspiring performance with Audi Genuine Alloy Wheels. Audi experts have meticulously designed these wheels especially for each Audi model. They're engineered to the highest standards and endure rigorous testing to help ensure long-term quality. Experience eye-catching style that is yours and yours alone. Nothing enhances the bold, dynamic look of your Audi vehicle faster.

Audi TravelSpace Transport Accessories

For every season and every getaway, Audi takes you there. Never leave the necessary gear behind. Be ready for any journey with Audi TravelSpace Transport Accessories. The list includes bike racks, ski racks, a variety of water sports equipment carriers and various sizes of cargo carriers. Wherever you go, make sure everything fits with a variety of intelligent and innovative solutions. Accessories designed for your active, passionate lifestyle.

Audi Genuine Electronics Accessories

The illuminating technology that graces each Audi vehicle provides the inspiration for Audi Genuine Electronics Accessories. Similarly, all of these accessories are impressively advanced and inspiring. Our audio options let you enhance your listening pleasure. Other accessory options help promote more convenient travel. All are designed and tested to help ensure compatibility with the vehicle's electrical systems, allowing you to enjoy every aspect of Audi technology with almost all your senses. Demand the best and drive with added confidence.

Audi Guard Comfort and Protection Accessories

Help protect what you love. Audi Guard Comfort and Protection Accessories offer functional, practical items that help keep your Audi in pristine condition. Choose from such useful items as trunk liners that help make clean-up quick and easy or an easy-to-use storage cover that helps shield the vehicle. Use them all to help reduce wear and tear and keep the vehicle looking like new—inside and out. All are engineered to stringent Audi standards, so you can be assured of their quality and durability.

¹ Audi Genuine Accessories purchased from an authorized Audi dealer are covered for the greater of: (1) the accessory limited warranty period (12 months or 12,000 miles, whichever occurs first) from the time of purchase; or (2) the remainder of the Audi New Vehicle Limited Warranty period (4 years or 50,000 miles, whichever occurs first). See your authorized Audi dealer for details. ² All roof-rack system attachments require the base carrier bars. All attachments sold separately. ³ Recreational equipment, sporting equipment and luggage not included.

Note: A word about this brochure. Audi of America, Inc., believes the specifications in this brochure to be correct at the time of printing. However, specifications, standard equipment, options, fabrics, and colors are subject to change without notice. Some equipment may be unavailable when your vehicle is built. Please ask your dealer for advice concerning current availability of standard and optional equipment, and your dealer will verify that your vehicle will include the equipment you ordered. Vehicles in this brochure are shown with optional equipment. See your dealer for complete details on the Audi New Vehicle Limited Warranty, twelve-year limited warranty against corrosion perforation, and Audi 24/7 Roadside Assistance. (Roadside assistance coverage provided by Road America in the U.S. Certain conditions apply; see your dealer for details.) Tires supplied by various manufacturers. "Audi," all model names, "Audi connect," "Audi pre sense," "cylinder on demand," "FSI," "MMI," "multitronic," "quattro," "Sideguard," "Singleframe" and the Singleframe grille design, "S line," "S tronic," "TFSI," "Truth in Engineering," "ultra," and the four rings logo are trademarks or registered trademarks of AUDI AG. "AdBlue" is a registered trademark of the Verband der Automobilindustrie. "AudiPilot" is a registered trademark of the BOSE Corporation. "Bang & Olufsen" is a registered trademark of Bang & Olufsen. The BLUETOOTH word mark and logos are owned by the Bluetooth SIG, Inc., and any use of such marks by AUDI AG is under license. "BOSE" is a registered trademark of the BOSE Corporation. "Google," "Google Earth" and "Google Voice" are trademarks of Google Inc. "HD Radio" and the HD Radio logo are proprietary trademarks of iBiquity Digital Corporation. "Hemelink" is a registered trademark of Johnson Controls Technology Company. "ICEpower" is a registered trademark of Bang & Olufsen. "iPod" is a registered trademark of Apple Inc. "SiriusXM" and all related marks and logos are trademarks of Sirius XM Radio Inc. and its subsidiaries. "TDI" is a registered trademark of Volkswagen AG. "Iptronic" is a registered trademark of Dr. Ing h.c. F. Porsche AG. "Wi-Fi" is a registered trademark of the Wi-Fi Alliance. All other trademarks are the property of their respective owners. Some European models shown.

2015 | A6 Audi of America

Audiusa.com

Facebook.com/Audi

AoA1515485



© 2014 Audi of America, Inc. Printed in the U.S.A.