



It helps friends and ends meet.

There's nothing like a Suzuki Samurai 4 X 4 to put a little more play into your day. Whether you're on the job, or on the town, the Samurai never lets you down. You've never driven anything that's quite so much fun. That's great as a playmate, yet unbeatable as a workhorse. That doesn't have to be in motion to cause a commotion. Because it's loaded with personality, and you can deck it out to make it dazzle the crowds even more. The Samurai is designed to let you do it all in style.

You can fill the Samurai with friends, or load it with cargo. It has room to really pack it away. If you're in the mood for a smile, there's no better way to get around. Nothing else comes close when it comes to an exciting ride. Nothing else comes close to giving you a better run for your money.



It's even fun picking which one.

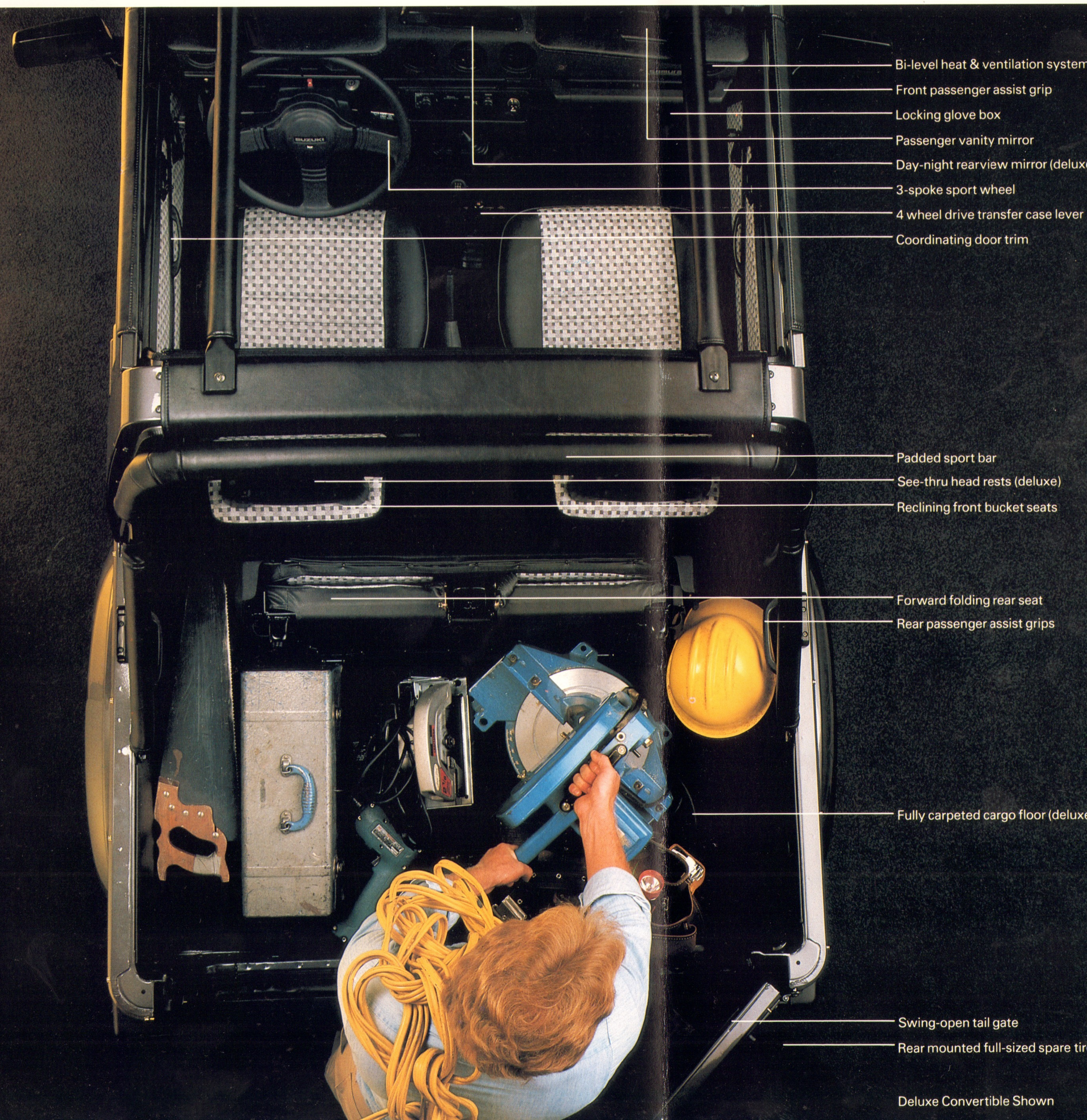

- Bi-level heat & ventilation system
- Front passenger assist grip
- Locking glove box
- Passenger vanity mirror
- Day-night rearview mirror (deluxe)
- 3-spoke sport wheel
- 4 wheel drive transfer case lever
- Coordinating door trim

- Padded sport bar
- See-thru head rests (deluxe)
- Reclining front bucket seats
- Forward folding rear seat
- Rear passenger assist grips

- Fully carpeted cargo floor (deluxe)

- Swing-open tail gate
- Rear mounted full-sized spare tire

Deluxe Convertible Shown

Once you drive a Samurai, you'll want to buy a Samurai. That's the easy part. The hard part is deciding which one to pick. But oh what fun. Let's say you're the kind of person with your head in the clouds. You'll probably be a candidate for the convertible. Of course, if you want a roof over your head, the Samurai hardtop is right up your alley. And we even have the Samurai in a truck version, which has no back seat and over 18 cubic feet of rear cargo space.



Truck version.



Deluxe Hardtop interior with full cloth upholstery, tachometer, digital clock, and built-in AM/FM stereo cassette.



Stylishly designed standard dashboard.



Standard and deluxe front bucket seats.

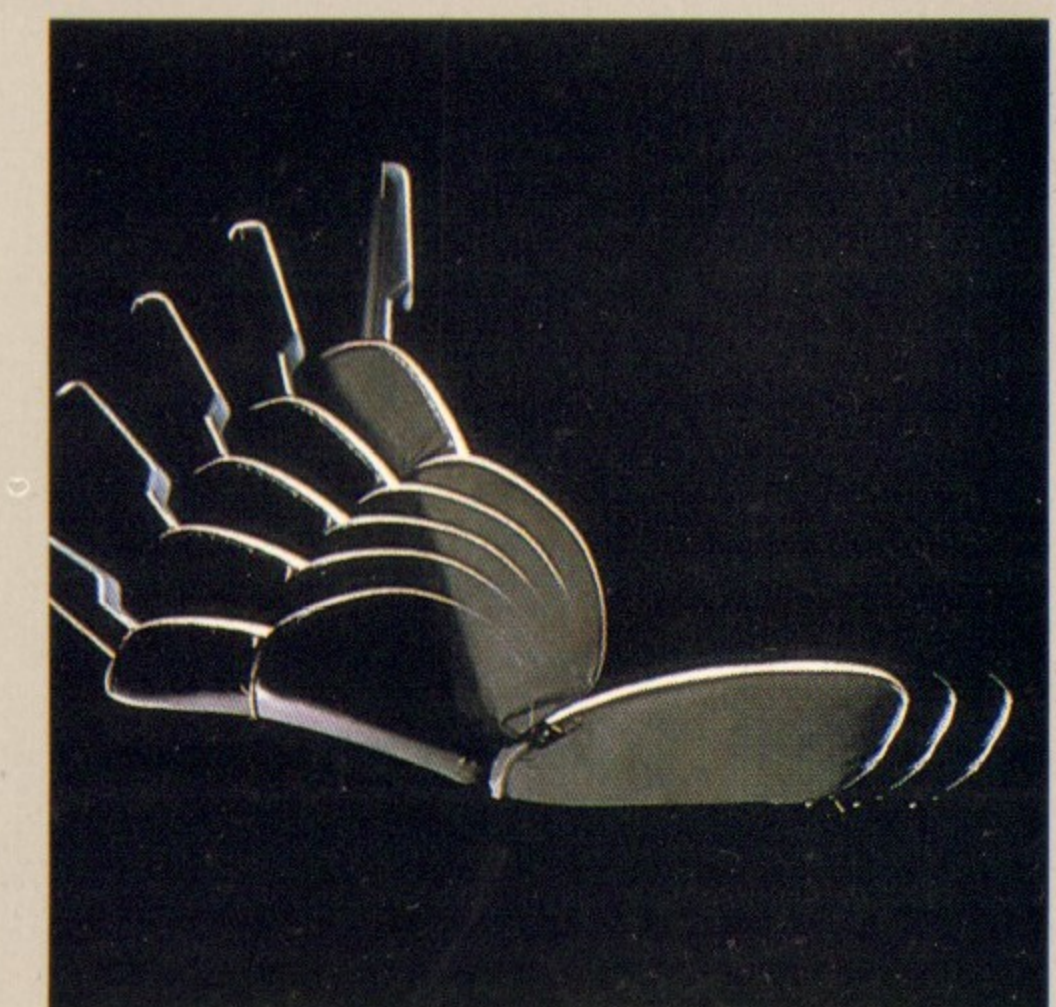

Reclining and sliding front seats.



Standard and deluxe meter panels.

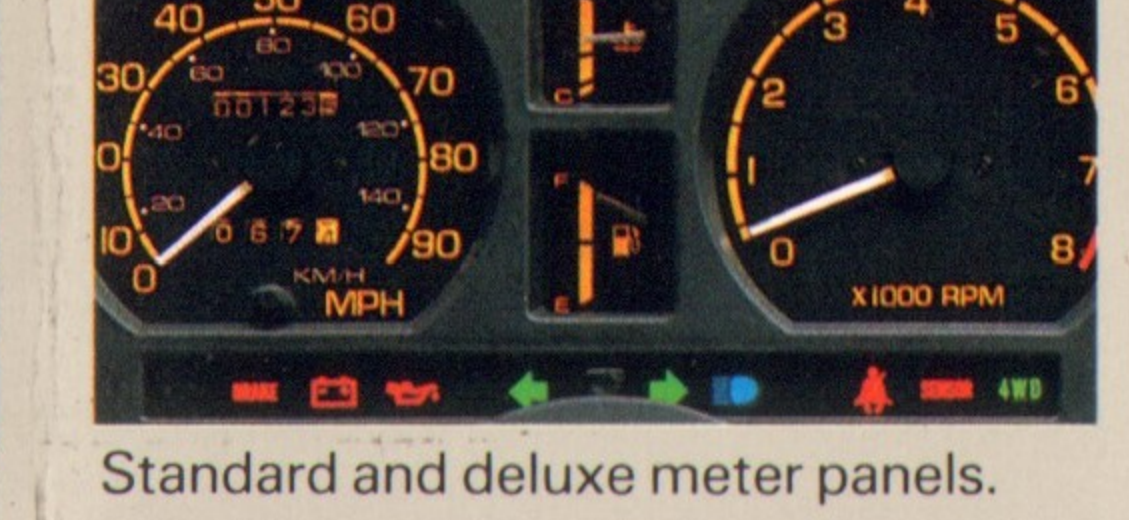

Deluxe hardtop's rear window defroster.

FEATURES

Convertible Hardtop

Standard Truck Deluxe (UX) Standard Truck Deluxe (UX)

FEATURES	Convertible Standard	Convertible Truck	Convertible Deluxe (UX)	Hardtop Standard	Hardtop Truck	Hardtop Deluxe (UX)
ELECTRICAL						
Trip Meter	◆	◆	◆	◆	◆	◆
Cigarette Lighter	◆	◆	◆	◆	◆	◆
Wiper (2-Sp. & Intermittent)	◆	◆	◆	◆	◆	◆
3-Position Interior Light	◆	◆	◆	◆	◆	◆
Penetrating Light Illumin. for Meter Panel	◆	◆	◆	◆	◆	◆
Penetrating Light Illumin. for Airflow Control Panel	◆	◆	◆	◆	◆	◆
4WD Indicator Lamp	◆	◆	◆	◆	◆	◆
INTERIOR						
Tachometer			◆			◆
Digital Clock			◆			◆
Day/Night Inside Mirror			◆			◆
Vanity Mirror (Passenger Side)			◆			◆
See-Through Front Head Restraint			◆			◆
Newly Designed Seat	◆	◆		◆	◆	
Deluxe Seat and Inside Trim			◆			◆
Sport Style Front Bucket Seat			◆			◆
Full Flat Folding Front Seat			◆			◆
Increased Passenger Seat Slide	◆	◆	◆	◆	◆	◆
Front Carpet	◆	◆		◆	◆	
Front and Rear Full Carpet			◆			◆
Rear Defogger						◆
AM/FM Stereo with Cassette			◆			◆
Air Conditioner (Deluxe II only)			◆			◆
Vinyl Seats	◆	◆		◆	◆	
Full Cloth Seats						◆
EXTERIOR						
Deluxe Canvas			◆			
Exterior Sport Mirrors	◆	◆	◆	◆	◆	◆
Wheel Center Caps			◆			◆
Sport Stripes			◆			◆
Key Locked Fuel Tank Cap	◆	◆	◆	◆	◆	◆
Grade Emblem			◆			◆

COLORS



Materials, equipment, colors, models, specifications, and accessories subject to change without notice.

Please be advised the Samurai handles and maneuvers differently than a conventional passenger car. Avoid sharp cornering, abrupt maneuvers, and always wear your seat belt. For specific information, read your owner's manual.

It gets you out of your rut.

/// If ever there was a 4 X 4 ready to challenge a rocky road, the Samurai is it. This power packed 4 wheel drive machine may be a kick in the city, but it really shows its stuff when you're in the rocks and ruts.

It's great for weekend getaways. For long trips or short jaunts. For camping, or cruising. In all sorts of rough and tough terrain. Under almost any weather condition. You'll find the Samurai ready, willing, and able to make the grade. Or cross the creek.

Because the Samurai is designed with over 8 inches of ground clearance, and puts all the vents, air intake, and electrical wiring well above whatever you're travelling over. Wet, dry or in between.

Wanna look hot on the trail, get out of your rut, and smooth out life's little ups and downs? Try a Samurai.



It even looks good under the hood.

 Suzuki has been making motorists happy with 4 wheel drive vehicles for over 16 years. In over 100 countries. And reconfirming an excellent reputation for reliability, durability, and excitability, year after year.

The Samurai has followed in the tire tracks of its predecessors. This mighty machine is a mechanical marvel. It packs plenty of punch with its 1.3 liter, 4 cylinder, SOHC engine. The compact, lightweight, steel sleeved aluminum engine displaces 1324 cc's, and is filled with weight-reducing innovations. You'll find the Samurai's engine weighs in under 200 pounds. And the total weight is considerably lighter than any other 4 X 4. The fully transistorized ignition gives great performance every time. And the two-barrel carburetor gives you all the spirit you need.

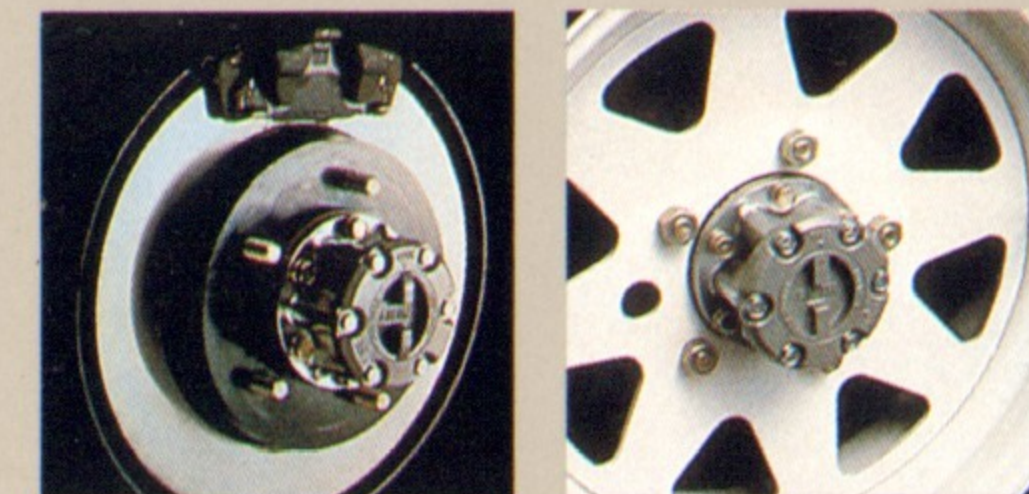

Front disc brakes and freewheeling hubs.

To put a stop to all of this, are the power assisted front disc brakes, with an automatic adjusting system on the rear drum brakes. To switch over to 4WD, just engage the free-wheeling hubs, shift into 4 wheel drive and you're ready for action with Samurai.

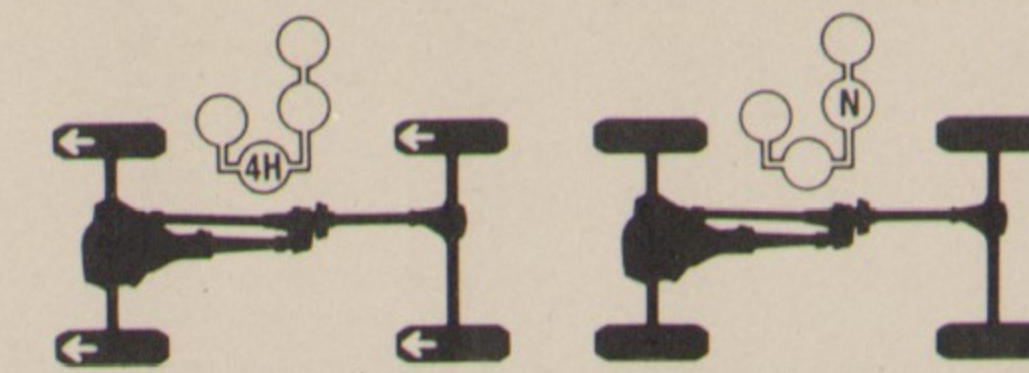
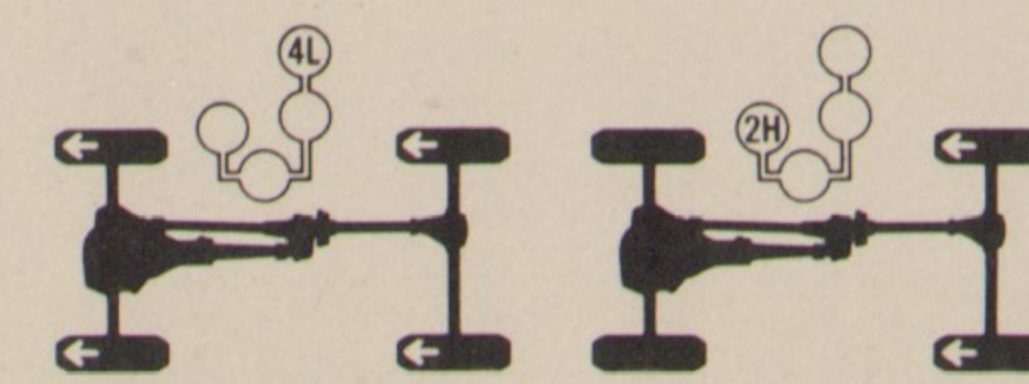

Another feature guaranteed to win you over is our 5th gear overdrive. The Samurai's 5 speed transmission gives you great economy when you're cruising down that long, open highway. The efficient performance is also due to the Samurai's excellent power to weight ratio.



5 speed and 4WD stickshifts.



Bridgestone heavy-duty tires.

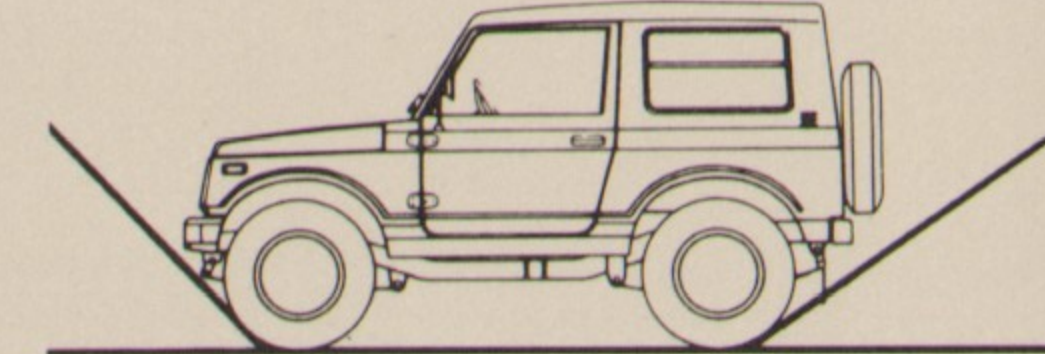

43° A/A 38° D/A
8.1" Ground Clearance

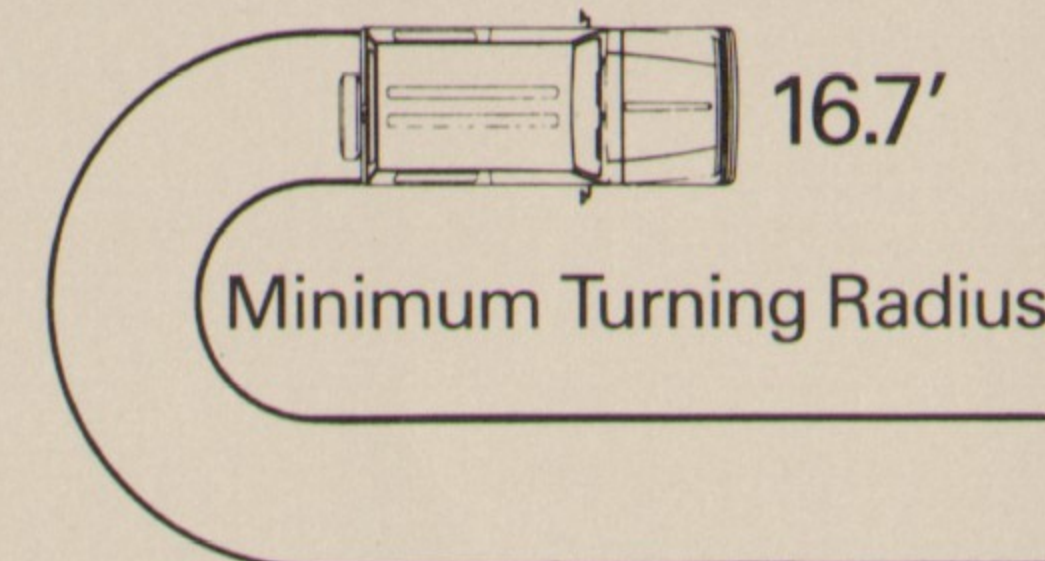

16.7' Minimum Turning Radius

You'll discover the Samurai's turning radius a plus. It's a mere 16.7 feet. You'll be able to get yourself out of all sorts of tight spots.

If all of this sounds pretty impressive, wait until you check the specs on this chart.

SPECIFICATIONS	Convertible	Hardtop
DIMENSIONS		
Overall Length	135.0in	135.4in
Overall Width	60.2in	60.2in
Overall Height	65.6in	65.6in
Wheelbase	79.9in	79.9in
Track: Front	51.2in	51.2in
Rear	51.6in	51.6in
Load Deck: Length	25.6in	24.8in
Truck Version	32.5in	31.7in
Folding Rear Seat: Width	50.0in	47.8in
Height	40.2in	41.1in
Ground Clearance	8.1in	8.1in
Approach Angle	43°	43°
Departure Angle	38°	38°
WEIGHT		
Curb Weight	2094lbs	2127lbs
Gross Vehicle Weight Rating	2932lbs	2932lbs
Gross Axle Weight Rating: Front	1257lbs	1257lbs
Rear	1576lbs	1576lbs
Seating Capacity	4	4
Truck Seating Capacity	2	2
ENGINE		
Type	Four-stroke cycle, Water cooled, OHC	Four-stroke cycle, Water cooled, OHC
Number of Cylinders	4	4
Piston Displacement	80.8in	80.8in
Bore	2.91in	2.91in
Stroke	3.03in	3.03in
Compression Ratio	8.9:1	8.9:1
Maximum Output	64 hp at 5500 rpm	64 hp at 5500 rpm
Maximum Torque	74lb.ft. at 3500 rpm	74lb.ft. at 3500 rpm
TRANSMISSION		
Clutch Type	Dry, Single disc	Dry, Single disc
Transmission Type	5-forward all synchromesh, 1-reverse	5-forward all synchromesh, 1-reverse
Gear Ratio: (1, 2, 3, 4, 5)	3.652, 1.947, 1.423, 1.000, 0.795	3.652, 1.947, 1.423, 1.000, 0.795
(reverse)	3.466	3.466
Transfer Gear Box Type	2-speed constant mesh	2-speed constant mesh
Transfer Gear Ratio: Low	2.268	2.268
High	1.409	1.409
SUSPENSION		
Front & Rear	Leaf spring with double action	Leaf spring with double action
Tire Size, Front/Rear	P205/70R15	P205/70R15
STEERING		
Steering Gear Box	Ball nut type	Ball nut type
Minimum Turning Radius	16.7ft	16.7ft
BRAKES		
Front	Power assisted disc (floating caliper type)	Power assisted disc (floating caliper type)
Rear	Power assisted drum (leading and trailing)	Power assisted drum (leading and trailing)
Parking Brake	Mechanical actuated on rear two wheels	Mechanical actuated on rear two wheels
CAPACITIES		
Fuel Tank	10.6 gallons	10.6 gallons
FUEL ECONOMY		
City*	27mpg	27mpg
Highway*	29mpg	29mpg

*1987 EPA Estimates. Use these estimates for comparison. Actual mileage may vary depending upon trip length, speed, and weather. Actual highway mileage will probably be less.

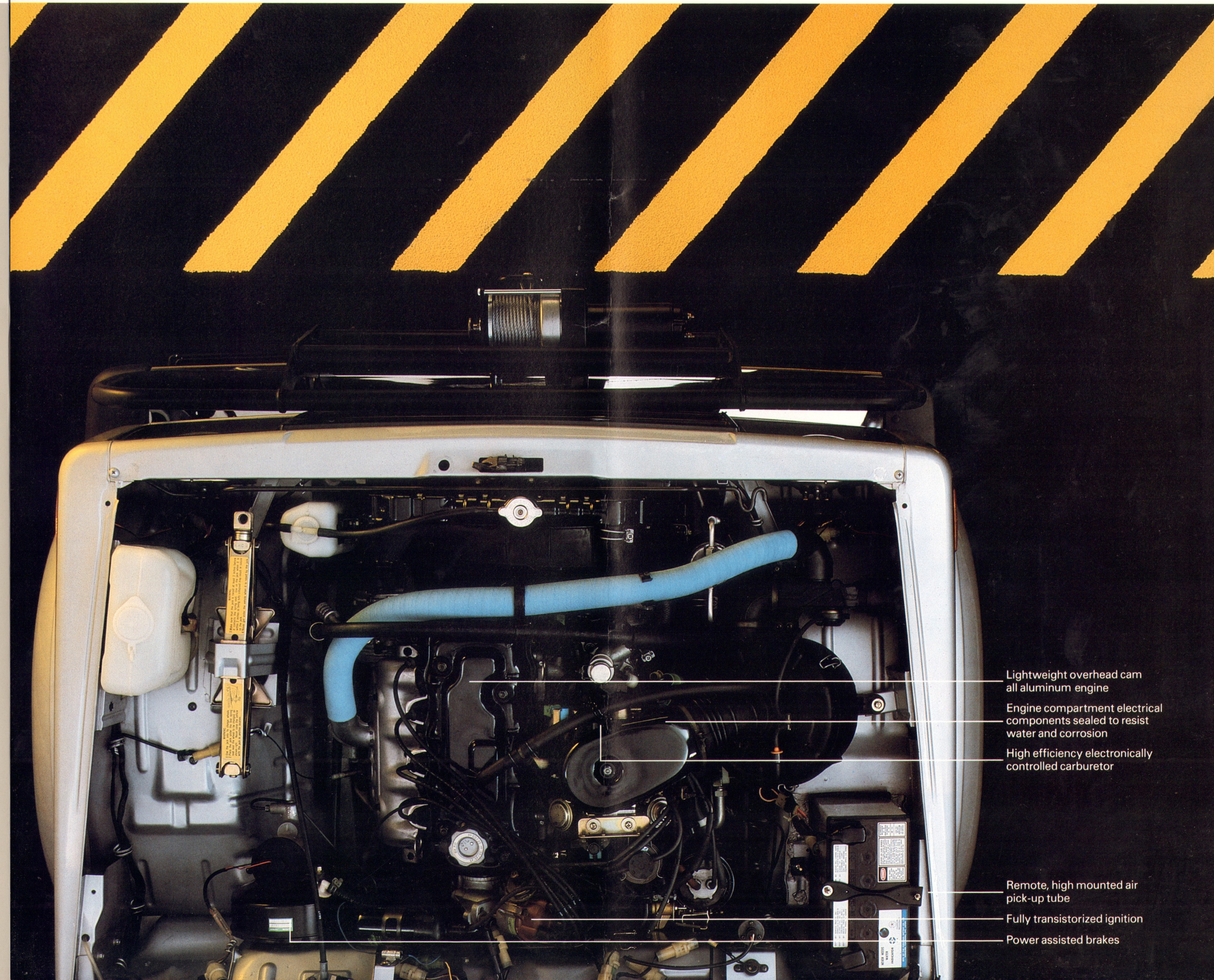

Lightweight overhead cam all aluminum engine

Engine compartment electrical components sealed to resist water and corrosion

High efficiency electronically controlled carburetor

Remote, high mounted air pick-up tube

Fully transistorized ignition

Power assisted brakes

It's great for an ego trip.

With a Samurai, it's easy to let the real you show through. The Samurai lets you reflect your own special style. It has over 90 accessories ranging from chrome wheels for a touch of cool, to brush guards, and functional roof racks. Whichever way you dress it up, you'll be instantly recognized as a very hip, very practical kind of person. A person who knows how to have lots of fun and excitement for their money.

And speaking of money—you won't believe how little of it you need to buy and maintain your Samurai. So march right up to the Suzuki dealer and tell them you want your Suzuki Samurai right now! That's all you need to say to make sure you'll never have a dull moment behind the wheel again.

Jimmy's C O R R A L



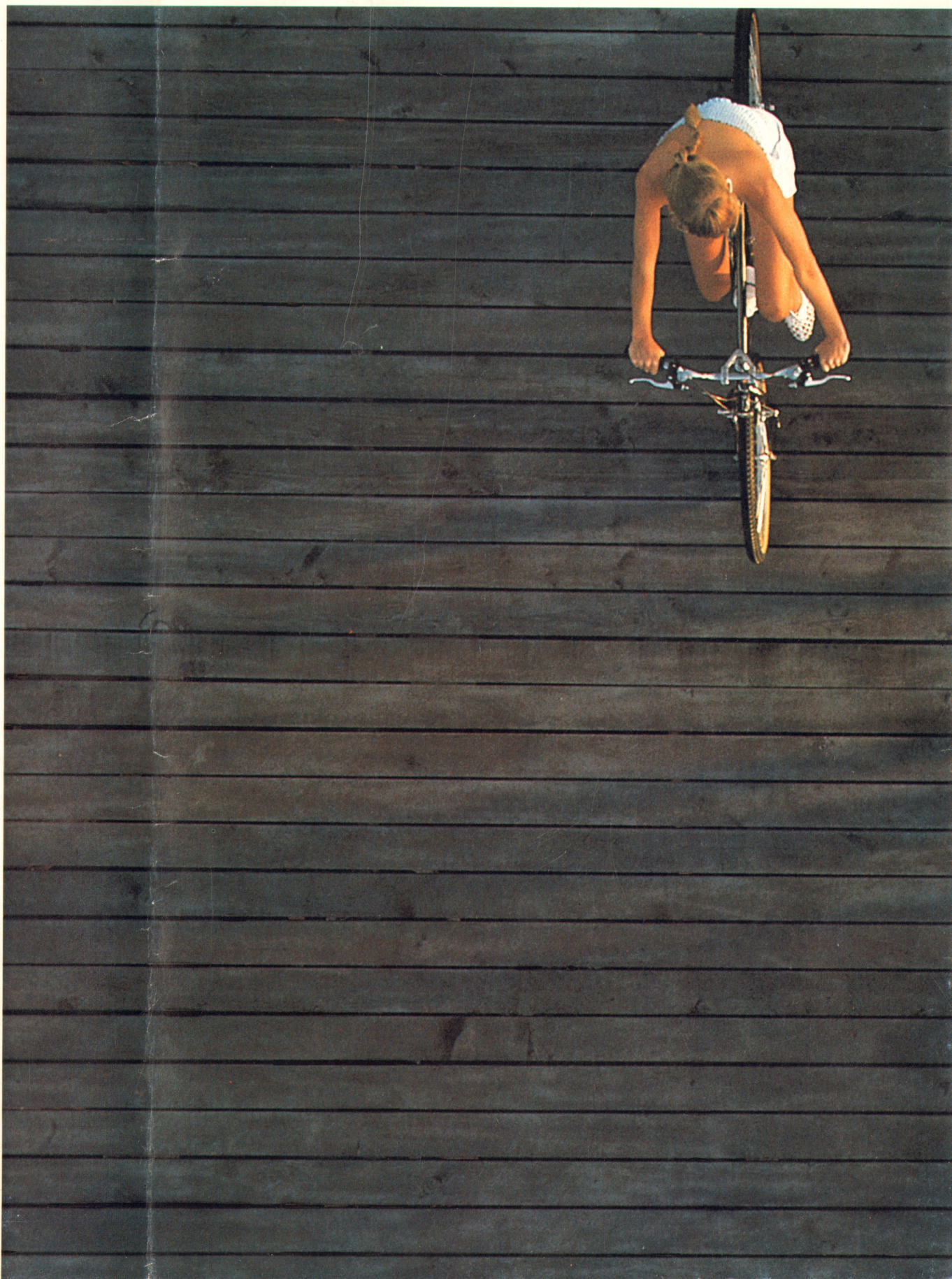

Suzuki of America Automotive Corporation
3251 E. Imperial Highway
Brea, CA 92621-6722

Buckle up for Safety.
99962-87301 9/86