

1 9 9 2

ISUZU
RODEO



At Isuzu, we believe that if we use the most solid engineering in the automotive industry, and not follow tradition just because it's acceptable, we can produce exciting,

A BETTER WAY TO GO.

dependable and reasonably priced vehicles that stand apart from the rest and take you out of the ordinary. • Our engineers take this philosophy as a challenge and obligation — to create a sport utility vehicle that's rugged and versatile to be sure, but with a level of refinement and comfort that makes it easy to live with, day in and day out. The Isuzu Rodeo is for drivers who think getting there should always be a smooth ride, whether you're going to work or to the woods. • The Rodeo is not the only sport utility vehicle on the road, but it stands alone in terms of quality and affordability. Designed to provide years of trouble-free service and built to the highest engineering standards, the Rodeo delivers outstanding value for your hard-earned dollar. • The Rodeo is offered in a choice of two-wheel drive and four-wheel drive versions to match your driving style and needs. You'll also find a selection of three trim levels: the well-equipped S, attractive XS and luxurious LS models, along with a choice of four-cylinder or V6 engine and 5-speed manual or 4-speed automatic transmission (with the V6). • All of which means that while you may have a difficult time deciding which stylish Isuzu Rodeo to choose, every one is definitely fun to drive and a joy to own.

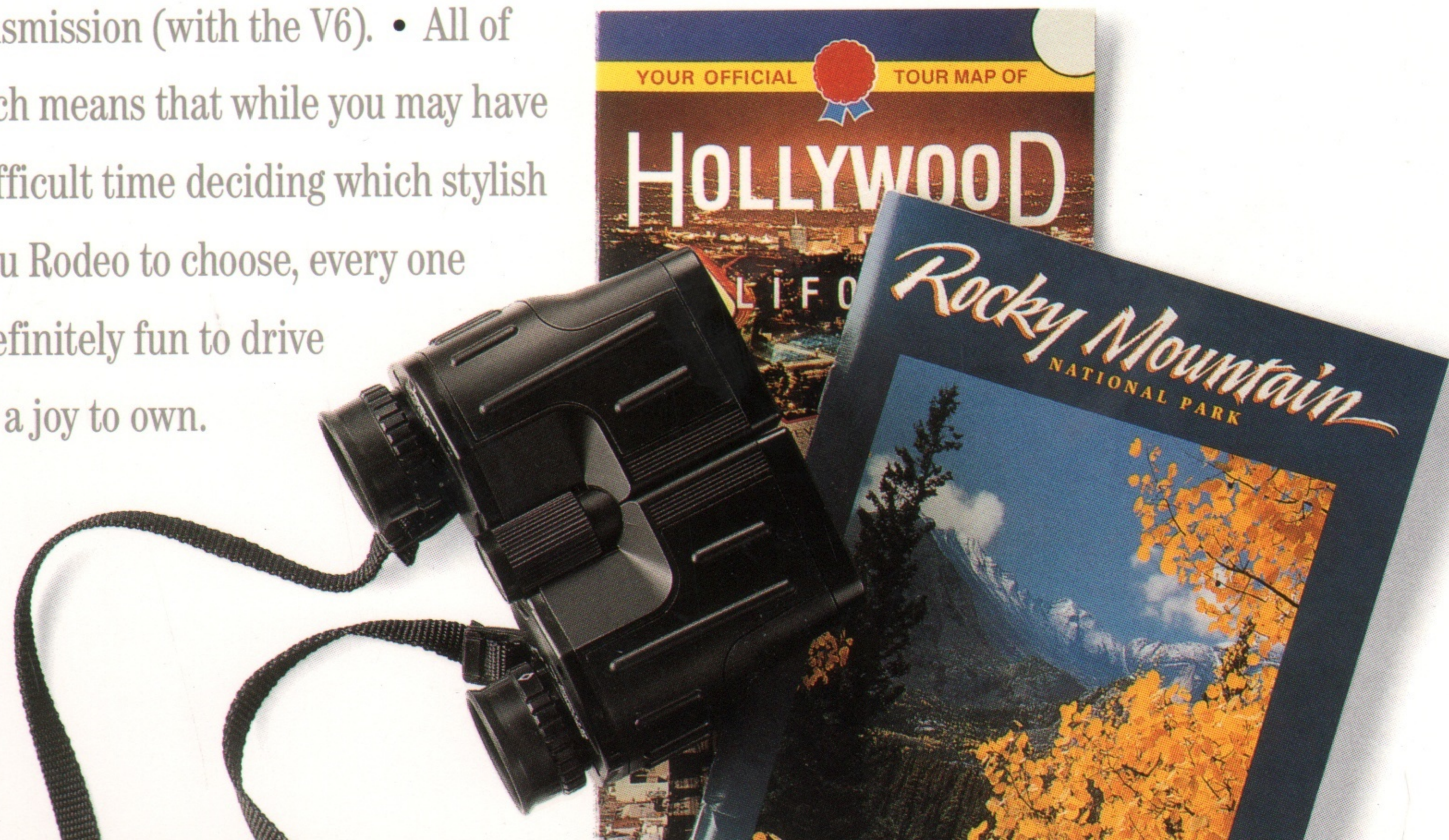

The four-wheel drive Rodeo LS provides the ultimate in performance and comfort, with a standard 3.1-liter V6 engine, choice of 5-speed manual or 4-speed automatic transmission, and an extensive array of luxury amenities. The beautifully appointed LS is also available in two-wheel drive models.



You can enjoy the added power of a 3.1-liter V6 engine in two-wheel drive Rodeo XS models. And for the best in all-weather, all-terrain versatility, select the four-wheel drive XS equipped with a two-speed transfer case and automatic locking hubs.



Our base model two-wheel drive Rodeo S comes with a high-efficiency 2.6-liter in-line four-cylinder engine, 5-speed manual transmission and six-passenger seating. The four-wheel drive Rodeo S draws even more impressive power from its 3.1-liter fuel injected V6 engine, which is available as an option on the two-wheel drive model.



Rodeo XS 2WD



Rodeo LS 4WD



Those rare days you manage to get away with the kids are absolutely priceless. It doesn't really matter where you go or what you do, as long as you're all together. You try very hard to give your children all kinds

of new and exciting experiences. Times they'll fondly remember for the rest of their lives, just as you remember marvelous times from your own childhood.

For you, it was a station wagon with fake wood on the side. For your kids, it's the Rodeo, snug and secure, ready to carry your family off to new adventures and countless magical moments.

Today, your daughter rode a horse for the first time. You watched her face change from apprehension to sheer delight and heard her laughter carry across the quiet meadow.



Evenings like this are special.

You work hard and you deserve an occasional night on the town. Time to take full advantage of all the comfort and sophisticated style your Rodeo can provide.

You enjoy the special things, you've earned them, and the Rodeo fits your style beautifully. It's hard to believe you were able to find one vehicle that matches every element of your lifestyle so perfectly.

The stereo's playing your favorite music and you're enjoying the response of the V6 engine as you thread your way through the light, early evening traffic. You're certain now you'll make your eight o'clock reservation without a problem.

In fact, the restaurant's just ahead and valet parking wants you front-row center.



Rodeo LS 4WD

EXPERIENCE BRINGS WITH IT SPECIAL ADVANTAGES. ISUZU HAS A STRONG HERITAGE OF SUCCESSFUL, WELL-ENGINEERED SPORT UTILITY VEHICLES. ISUZU ENGINEERS KNOW WHAT WORKS AND WHAT DOESN'T. THEY'VE BUILT UPON THIS EXTENSIVE BASE OF KNOWLEDGE WHEN DESIGNING THE RODEO AND IT SHOWS — IN RODEO'S SUCCESSFUL BLEND OF PERFORMANCE, DURABILITY, VERSATILITY AND COMFORT.

SPACIOUS, COMFORTABLE AND ROOM WITH A VIEW.

Open one of the Rodeo's four wide-entry doors and slip inside.

You'll find a well-appointed and remarkably roomy interior with over 37 inches of front and rear seat head room, an expansive 42 inches of front seat leg room (with over 36 inches to stretch out in the rear), and a full 35 cubic feet of cargo space behind the rear seat. That adds up to room for you, your family and all your luggage or sports equipment.

SEATING FOR SIX

With its standard, full front bench seat, the two-wheel drive Rodeo S (shown at right) offers seating and comfort for a family of six. All other models feature wide, supportive front bucket seats and the same three-across seating in back. The rear seat also folds forward to give you 67.3 inches of flat floor length for hauling bulky cargo. And Rodeo LS models offer the added versatility of a split-folding rear seat.

INFORMATION, PLEASE

The Rodeo's stylish cockpit doesn't just look great, it puts you firmly in control of the task at hand — driving. The combination of a raised seating position and plenty of large windows (with narrow, unobstructive roof pillars) gives you a commanding view of the road. With standard analog gauges and ergonomically designed instrument panel, all vital gauges and controls are right where you need them.

SAFETY FIRST

Since our designers understand that you'll be hauling the most precious cargo of all — your family — every Rodeo is engineered to help ensure their protection. Safety features include front and rear three-point seatbelts and rear child-safe door locks.

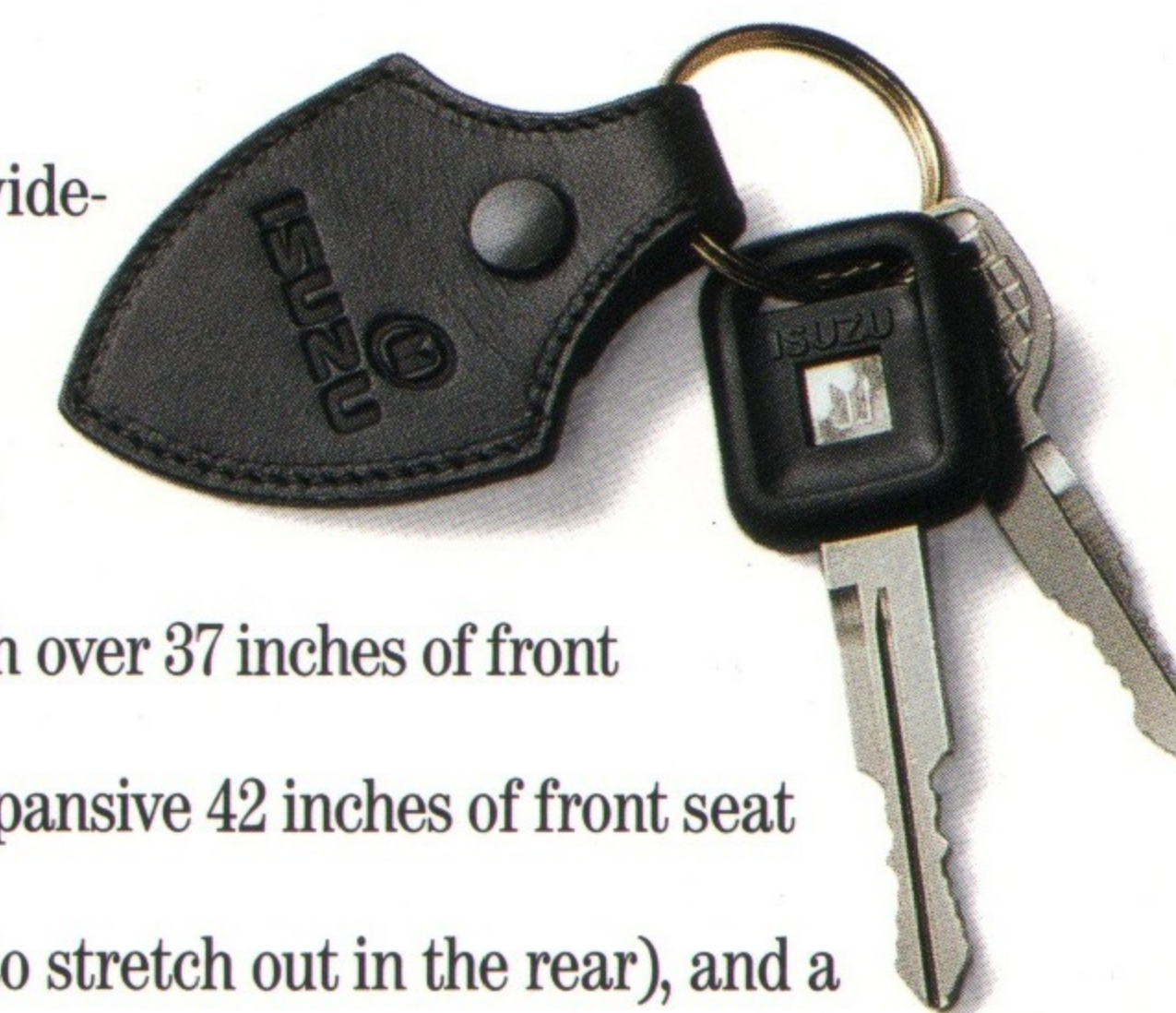

FULL FEATURES, FULL VALUE

Every Rodeo comes complete with a long list of comfort and convenience features. The S models offer you standard amenities such as tweed cloth upholstery, warning/indicator lamps, a large-grip three-spoke steering wheel, front and rear passenger-assist grips, tinted glass, two-speed windshield wipers with mist function, dual sport mirrors, rear window defogger, inside-mounted full-size spare tire with cover, and more. • The sporty Rodeo XS adds an AM/FM ETR stereo with two speakers, fully reclining front bucket seats, bright exterior mouldings, side stripes, rear window wiper/washer and an outside-mounted full-size spare tire with vinyl cover for four-wheel drive models — to name just a few. • For those demanding even more amenities, the top-of-the-line LS offers the addition of bright lower body side moulding, adjustable tilt steering column, cargo area convenience net, front door map pockets, digital clock and an AM/FM ETR/logic stereo cassette with four speakers.

AND EVEN MORE

Depending on the model, you can further custom fit your Rodeo with additional items such as air conditioning, lockable center console with armrest, compact disc player, Bosch light bar with lights, and Yakima® roof rack. Plus, on LS models, there's an available Convenience Package that includes a tilt-up/removable sunroof, power windows and door locks with remote tailgate opener, and cruise control.

The Rodeo's cargo area is easy to get at. The rear glass hatch is designed to open independently of the tailgate for convenience in loading and unloading. And with the tailgate down, you've got a low lift-over height for cargo, and a convenient platform for impromptu picnics.



With more than 36" of leg room and a wide rear seat (with split folding feature on LS), the Rodeo provides comfortable rear seating for three. Fold the rear seat down to accommodate extra-long cargo.

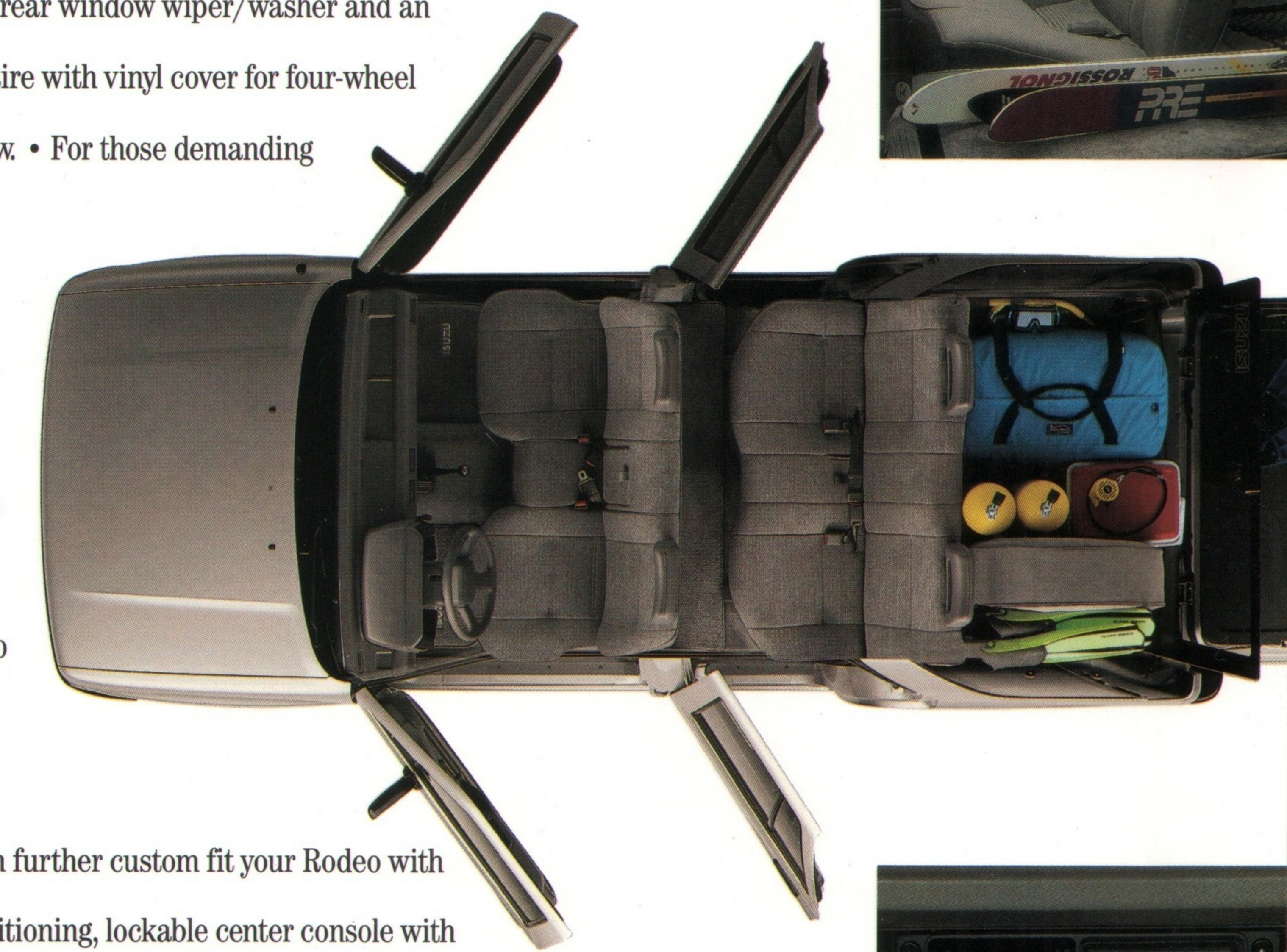

(Above) The two-wheel drive Rodeo S with 2.6-liter engine features bench seats front and back.

(Right) Sound systems available include an AM/FM stereo cassette and compact disc player.



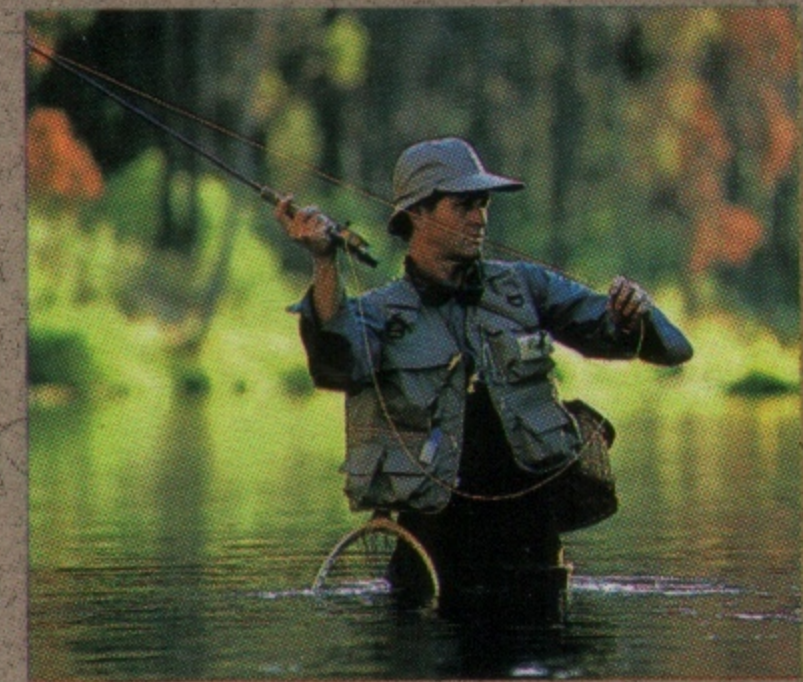

Sometimes you don't speak for what seems like hours. It's as if neither of you wants to break the spell. You are lost in your own world, listening to the swift, running water tumble over glistening river stones. You cast again, watching the current carry your hand-tied fly toward the eddy where that fat, brown trout just rose. You'll release him, but you've got to catch him first. You're lucky to be here and you know it. It's a special place, and you're going to do your part to keep it that way. In the back country, the Rodeo is in its element and you're always in control. Not many people will ever find this place. Those that do won't even know you've been here. But that brown trout will still be waiting for them.



Rodeo S 4WD

THE SAME LONG WHEELBASE THAT GIVES THE RODEO ITS INCREDIBLE INTERIOR ROOMINESS ALSO OFFERS AN EXCEPTIONALLY CIVILIZED AND COMFORTABLE RIDE. YET UNDERNEATH ITS REFINED AND STYLISH EXTERIOR IS THE HEART AND HARDWARE OF A TRUE RUGGED TRUCK. THINK OF IT AS A SPACESHIP WITH ALL THE RIGHT STUFF, CAPABLE OF GOING WHEREVER AND WHENEVER YOU WANT.

A SMOOTH APPROACH TO THE RUGGED OUTDOORS.

DURABILITY AND VALUE

With 77 years of experience, Isuzu knows what it takes to build a tough, dependable vehicle. That's why every Rodeo starts with a rugged, six-crossmember frame and uses corrosion-resistant galvanized steel throughout. The Rodeo is built to last, which makes it an outstanding value for your hard-earned dollar.

POWER TO SPARE

A pair of proven engines are offered with the Rodeo, beginning with the efficient 2.6-liter fuel injected four-cylinder that comes standard with the two-wheel drive Rodeo S. It pumps out 120 horsepower and 146 lbs/ft of torque. • Available as an option on the two-wheel drive S model and as standard equipment on all other Rodeo models, is a fuel injected 3.1-liter V6 that delivers 120 horsepower and an impressive 165 lbs/ft of torque for gutsy on-road or off-road performance.

ANTI-LOCK STOPPING POWER

As part of Isuzu's commitment to your safety, every Rodeo comes equipped with a Rear-Wheel Anti-lock Brake System which modulates rear braking pressure to help prevent lockup in hard braking situations. Every Rodeo also features power-assisted front vented disc brakes.

TWO TRANSMISSION CHOICES

Our standard 5-speed manual transmission provides precise engagement and gear ratios specially matched to each engine's power curve. • Available as an option on XS and LS models equipped with the 3.1-liter V6 is a refined 4-speed automatic transmission with

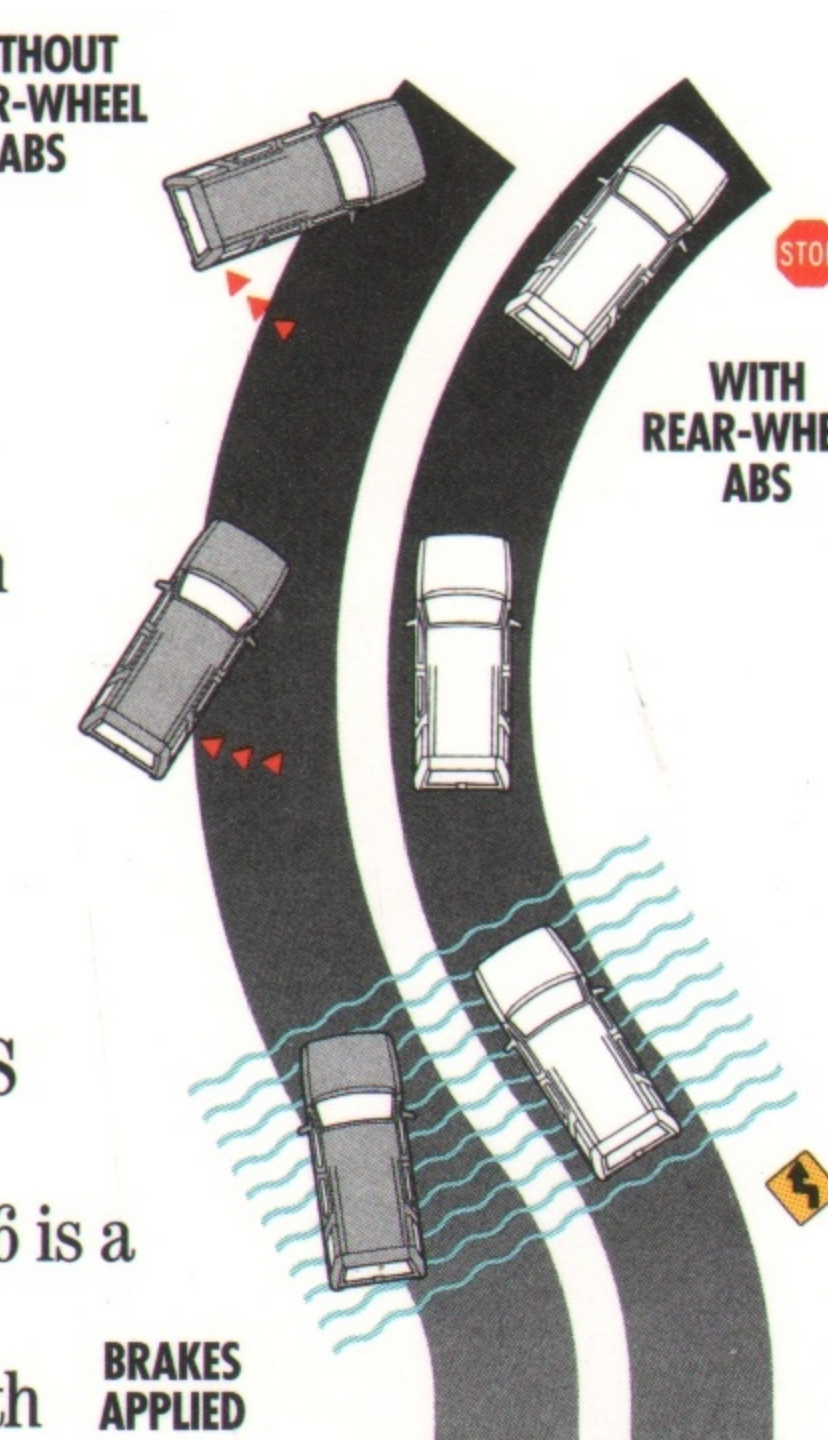

fourth gear overdrive. The automatic transmission also features an innovative "winter start" mode, which helps prevent rear wheelspin on slippery surfaces by starting out in third gear.

RUGGED SUSPENSIONS

Whether you choose two-wheel drive or 4x4, every Rodeo comes with an independent double-wishbone front suspension and double-acting shock absorbers for precise handling and a comfortable ride. A front stabilizer bar helps reduce body lean to keep the Rodeo level during cornering. • Recirculating ball-type steering is used on all models for direct road feedback. Speed-sensitive power-assist* steering gives you added assist at low speeds (e.g., when parking), then reduces assist at higher speeds for optimal road feel.

4X4 FUN

Four-wheel drive Rodeo models get you there and back with the addition of a 2-speed transfer case and automatic locking hubs (manual on S models). An available 4WD option is a limited slip differential (standard on XS models), which enhances traction on dry or wet surfaces, while large 31x10.5R15 tires mounted on lightweight aluminum wheels (standard on XS models) provide added all-terrain performance. • Every Rodeo sits at "four-wheel drive" ride height, which means an exceptional ground clearance of 8.1 inches (9.3 inches with the 10.5R tires). Plus, every Rodeo is equipped with a 21.9-gallon fuel tank — one of the largest in its class — giving you miles of extra driving between fill-ups.

With 120 horsepower and 165 lbs/ft of torque, this advanced 3.1-liter V6 with throttle body fuel injection provides smooth, efficient operation — and the eager responsiveness that makes driving a lot more fun.

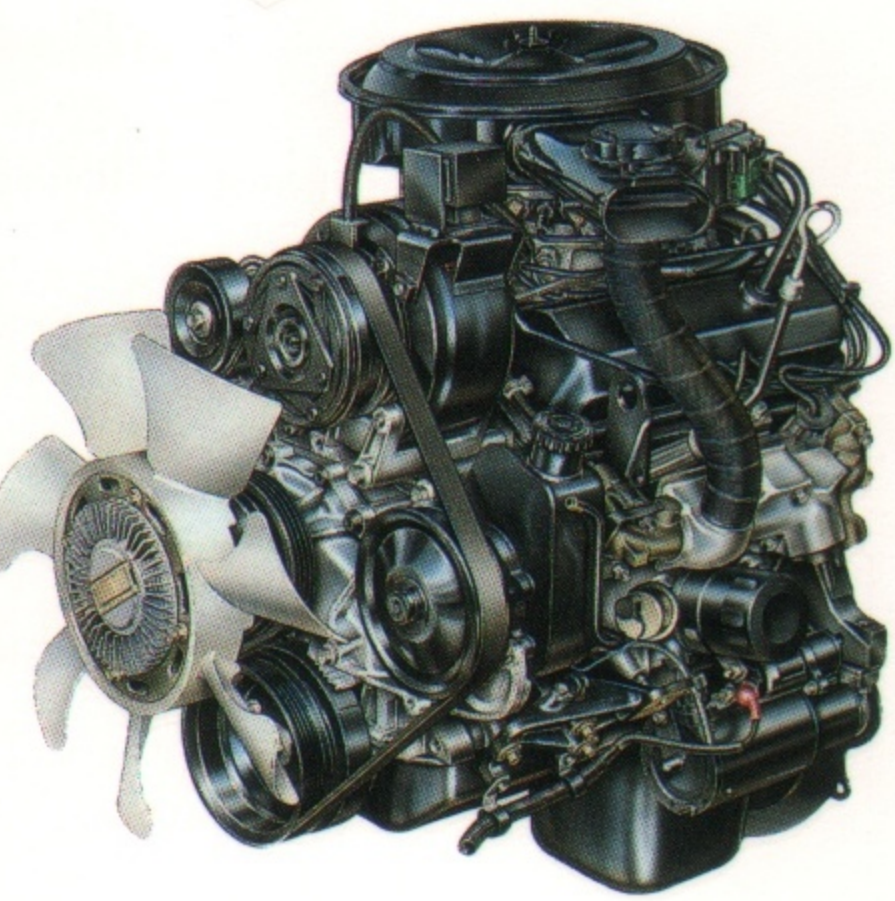

The optional four-speed automatic transmission (V6) utilizes an over-drive fourth gear for fuel-efficient highway cruising.

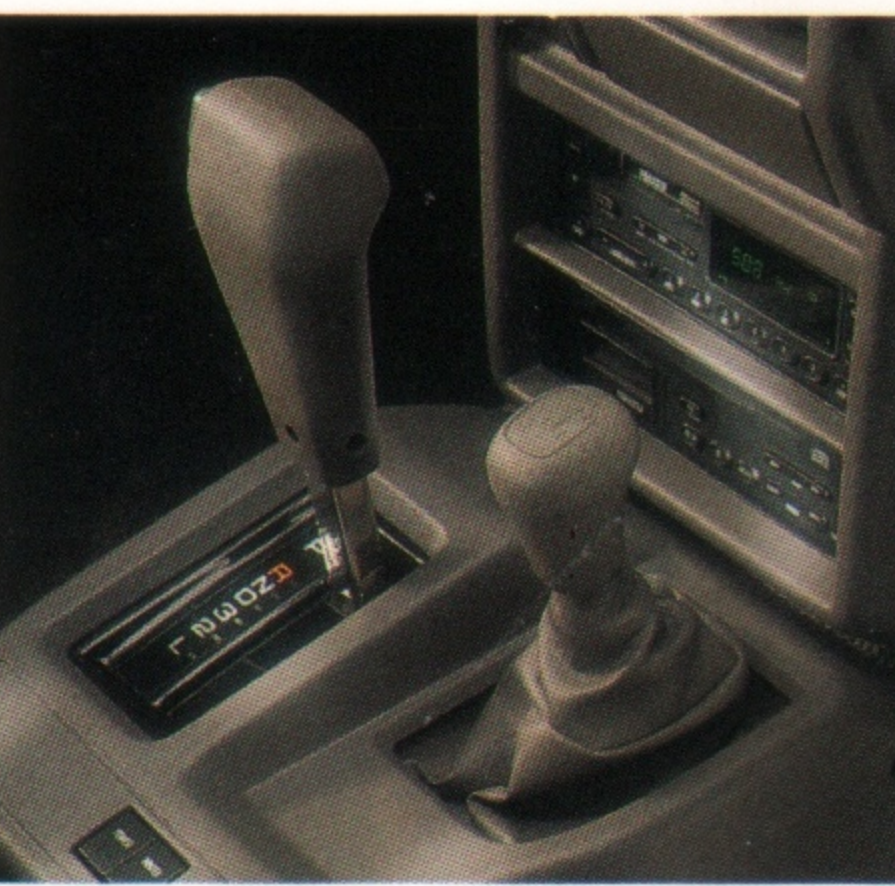

(Below) With a standard Class II/3,500-pound** towing rating (with V6 engine), the Rodeo is the perfect companion for a weekend at the lake or ocean.



(Right) The front double-wishbone suspension with stabilizer bar combines with a wide track and long wheelbase to provide stable handling and a comfortable ride, on-road or off. Large front disc brakes are standard. Plus, auto-locking hubs on XS and LS 4x4 models let you shift into four-wheel drive without leaving the comfort of the cab.

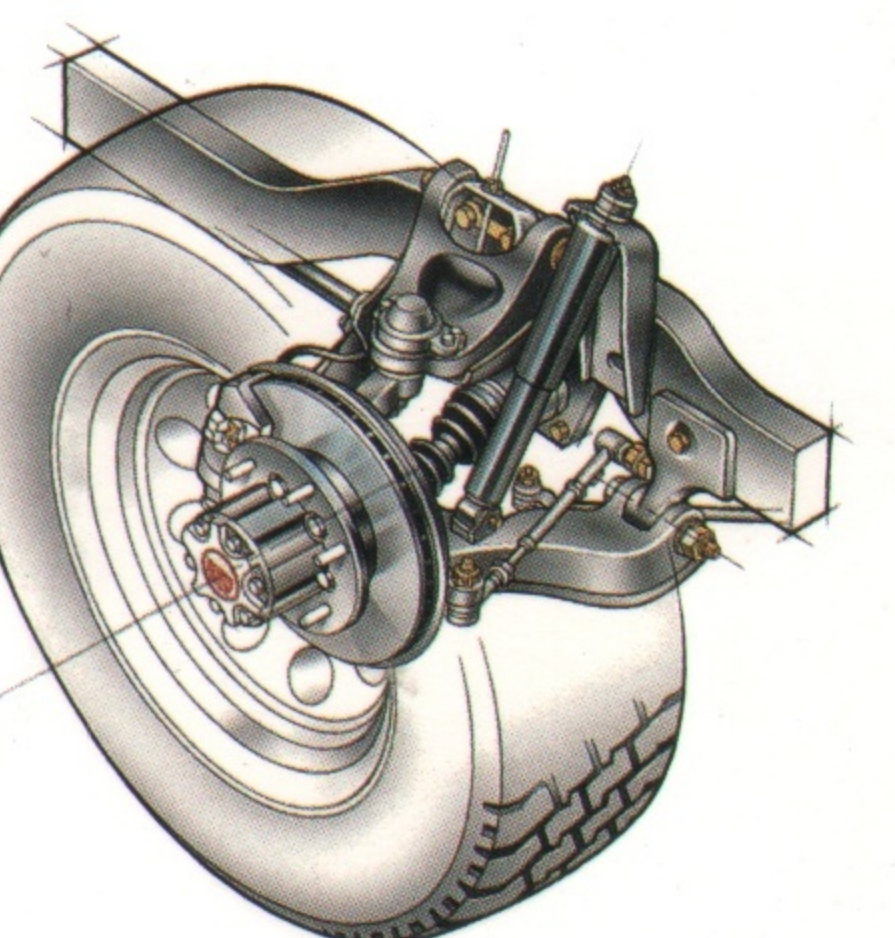

* Optional with 4-cyl. engine.
** With trailer brakes and appropriate hitch assembly.



THERE'S NO COMPARISON.

For 77 years, Isuzu has been building innovative, high-value vehicles. Today, Isuzu continues this tradition as a worldwide leader in high-excitement specialty cars and trucks. • From our state-of-the-art manufacturing facilities in Japan and our new assembly plant in Lafayette, Indiana, to our nationwide network of select Isuzu dealers and our strategically placed parts distribution centers, we're making an investment in ensuring your total satisfaction. It's a commitment that includes friendly, respectful sales consultants, specially trained service technicians and one of the automotive industry's top-ranked warranty programs – featuring our comprehensive 36-month/50,000-mile limited warranties and 72-month/100,000-mile rust perforation limited warranties. • From the first moment you enter an Isuzu showroom, and continuing for as long as you own your Isuzu, we are dedicated to ensuring your continued satisfaction. Of course, the best way to appreciate an Isuzu is to test drive one. We invite you to drive one at your nearby Isuzu dealer today.



STYLUS



IMPULSE

The affordable Isuzu Stylus gives you true sport sedan excitement at a compact price. • The sporty Isuzu Impulse provides leading-edge technology – including a turbocharged, all-wheel drive model – for an unequalled driving experience.



AMIGO



PICKUP

Fun on the run – or under the sun – starts with the stylish Isuzu Amigo, which is available in both two- and four-wheel drive. • And for rugged, tough truck performance in a range of body styles from Regular Cab to Spacecab, we offer a full lineup of powerful compact Pickups.



RODEO

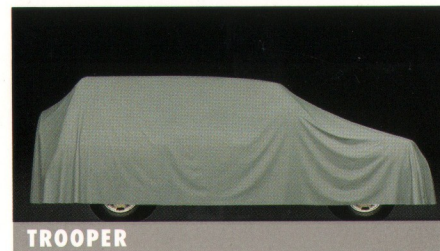

TROOPER

For all-purpose, all-weather family driving, there's the beautiful, roomy Isuzu Rodeo sport utility vehicle. • And, coming in 1992, an all-new breed of Trooper – an exciting new standard for on- and off-road driving performance from Isuzu.

BUCKLE UP FOR LIFE!

AMERICAN ISUZU MOTORS INC.
AIMI-MKT-092-200M