

L ST.

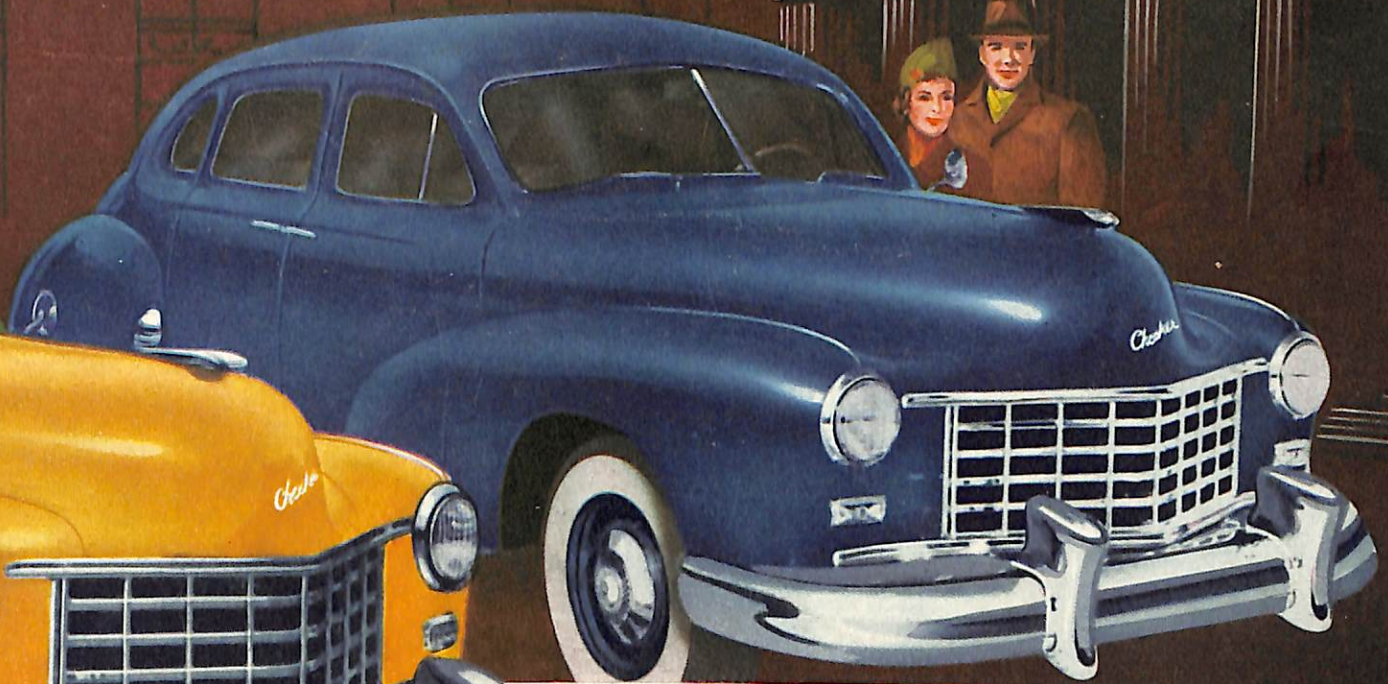

The
1950
Checker

C A B A N D L I M O U S I N E S E D A N

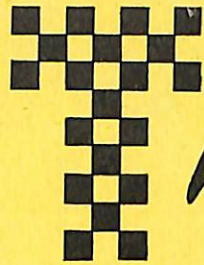

Whifty for 50...

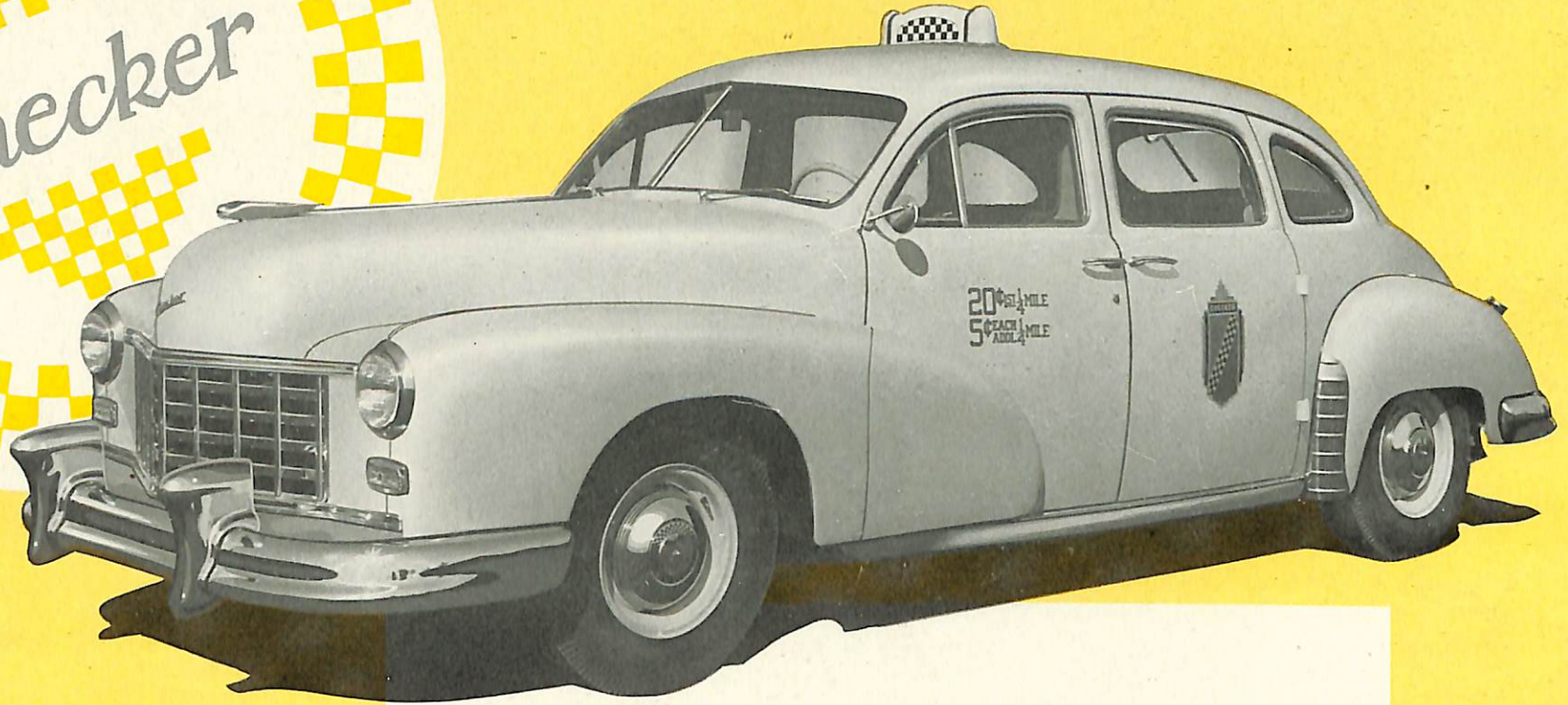

THE 1950 CHECKER

MODEL A-4 TAXICAB

MODEL A-5 LIMOUSINE

The New 1950 Model Checker Taxicabs are completely redesigned for beauty, comfort and increased net operating revenues. A host of improved features give you a cab which costs less to operate and maintain . . . provides maximum driver and passenger comfort. Best for beauty, best for safety, Models A-4 and A-5 are the only vehicles built exclusively for taxicab service. Model A-4 is the Partition Type Cab with single driver's seat; Model A-5 is the Suburban Limousine Type with full width front seat.



COMPLETELY NEW DRIVER COMFORT

Millions of tiny air bubbles in this newly designed foam rubber seat and backrest cushion the day's run. Unique, simple adjustment device makes possible 256 seat positions. The most comfortable driving position is assured every driver of any size or girth.

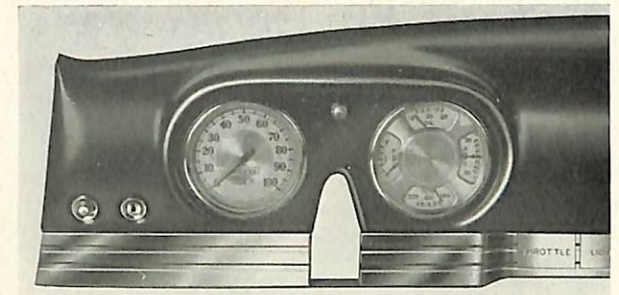

HANDSOME NEW INSTRUMENT PANEL

Redesigned instrument panel has all instruments and controls conveniently grouped for efficient operation. Controls of flush design combine beauty with safety. Parking brake is quick acting and easily accessible.

for greater
driving



LUGGAGE COMPARTMENT

New, larger, more accessible luggage compartment with improved deck lid closure.



whiffty

NEW FEATURES

comfort

(and more profitable operation)

NEW BROADVIEW WINDOWS

Greater visibility all around. Increased windshield area, narrow corner posts, and lowered hood all combine to give driver relaxed and safe visibility.

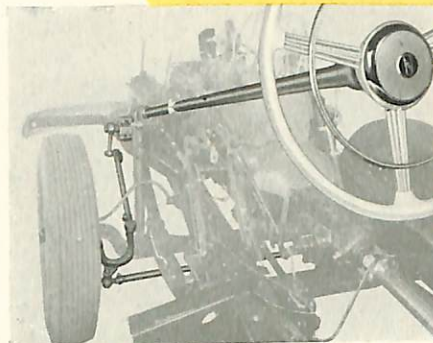

EASIER STEERING

New Ross roller bearing mounted Cam and Lever Type Steering Gear.

Drivers handle the new Checker with unrestrained ease. Actual scientific tests prove that less driver effort is required to make turns. (See Table A)

TABLE A

STEERING EFFORT

Car	Model	Lbs. Effort Required
CHECKER A-4	1950	12.4
Pleasure Car A	1948	14.7
Pleasure Car B	1948	15.0
Pleasure Car C	1949	15.4

The above figures were obtained by measuring steering effort required with each car through the use of the Ross Torque Meter.

TABLE B

MINIMUM COMPLETE TURNING CIRCLE

Car	Diameter of Complete Circle
CHECKER A-4 & A-5	39' 6"
New York Cab A	46' 8"
New York Cab B	45' 1"
Pleasure Car A	44'
Pleasure Car B	41' 10"
Pleasure Car C	40' 4"

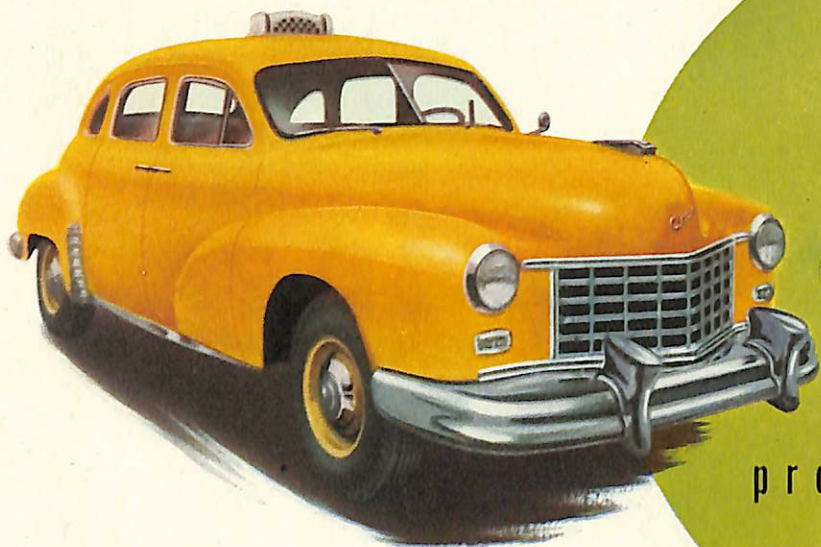

The 1950 Checker

a beautiful
profitable taxicab

The interior of the new Checker A-4 incorporates all of the desirable features. Roomy comfort for five forward riding adults. Safety features that protect both the passenger and the operator from expensive claims. All upholstered surfaces covered with easily-kept-clean attractive Vinyl plastic fabric.

The sturdy partition is designed to provide passenger privacy as well as protect driver's security. Heat is furnished to both driver and passengers by a heavy duty, two directional air conditioner drawing fresh air from the outside, at a high level above exhaust gases from preceding cars. Twin duct defrosters, operating in conjunction with fresh air heaters, completely eliminates inside frosting of windshield and windows. Air conditioner can be used as a cooling medium to both compartments during hot weather. Ample clear floor space for surplus luggage or two way radio installation is available at the right side of the driver's seat in front compartment.

All the beauty of a passenger car, but with the exclusive features that mean high-revenue, low-cost cab operation. That's the combination that makes the 1950 Checker tops for cab operation. There is no costly conversion package to be considered, Checker is taxicab all the way from the engineering drawing board to the day it's taken out of service. For the best in profit building service, it's the Thrifty for 'Fifty CHECKER.



hifty **NEW FEATURES**

for greater passenger comfort
(and more profitable operation)

EASILY CLEANED

All plastic material protects scuff points on lower door, rear seat heel board and lower back of partition — outlasts any fabric — washes with soap and water.



LARGE NEW AUXILIARY SEATS

Improved design features flat spring steel supports for greater strength and deeper cushions for greater comfort.



FLAT FLOOR

In rear eliminates bothersome hump. Gives more passenger room and reduces danger of tripping. New Blue-Moresque rubber non-slip safety floor mats.

SAFETY FINGER SHIELDS

Along door edges protect from pinched fingers. Smart two-tone vinelyte imitation leather trim throughout.

FOAM RUBBER PASSENGER CUSHION

New seat design reduces the possibility of passengers being thrown forward in case of sudden stop. Seat is engineered to stay put, yet is easily removable.

NEW VENTILATING REAR WINDOW

Smoke and stale air are whisked away through the new ventilating rear window. Automatic vacuum operation is controlled from the driver's seat. Operated in conjunction with the air conditioner it provides maximum cooling for warm days or hot climates.



Features of the *brifty for 50* CHECKER

the NEW built for the



Ventilating Rear Window

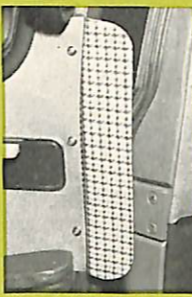

Finger Guard Safety Shields



Stronger, More Beautiful Hardware

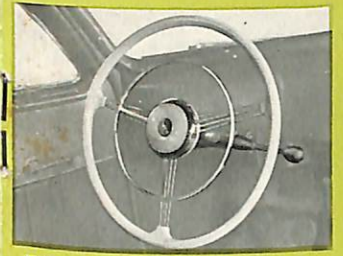

Effort Saving New Ross Cam and Lever Steering

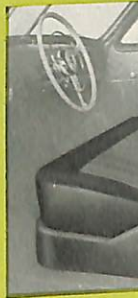

Full Front Model



Sponge Rubber Arm Rest, Convenient Ash receptacle and Fixed Grab Handle

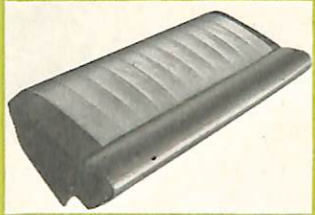

Foam Rubber Rear Cushions

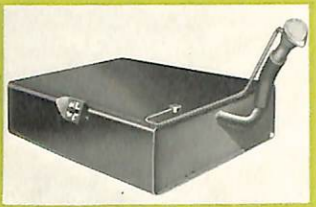
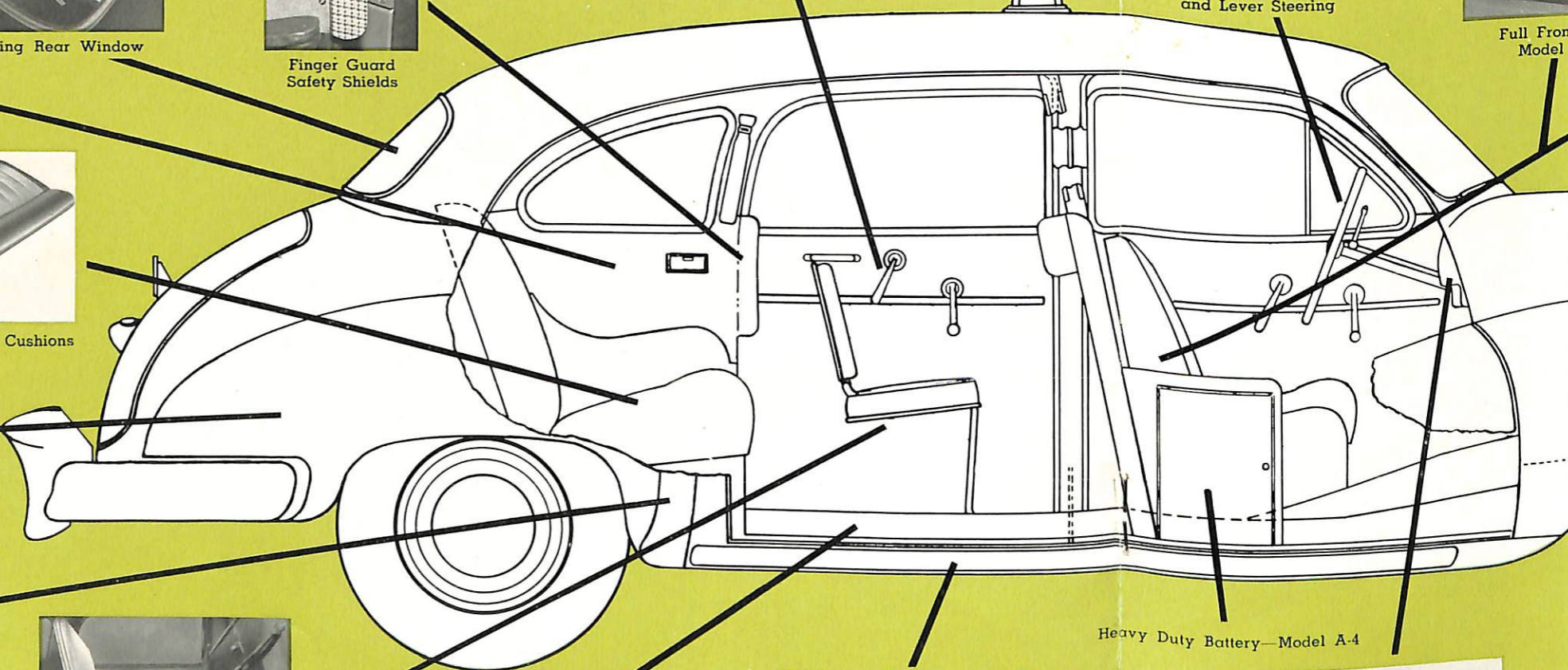

24 Gallon Gasoline tank with Vent-Alarm Signal to stop overflow waste



Big Chrome Gravel Guards

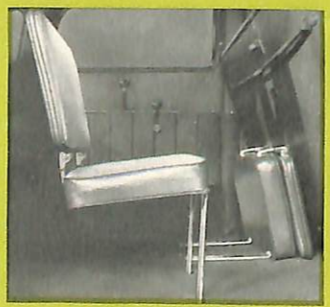

Improved Auxiliary Seats



Non-slip Blue-Moresque Floor Mats



Full-length Chrome Rub Rail Fender to Fender

Heavy Duty Battery—Model A-4

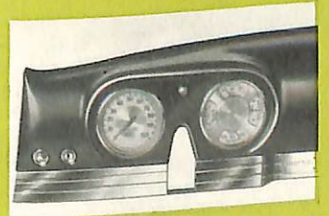

New Flush Instrument Panel with flush controls, and Tell-Tale Lite, signals driver when Rear Doors are not closed.

50 CHECKER

the NEW built for the purpose **TAXICAB**



Guard Shields



Stronger, More Beautiful Hardware

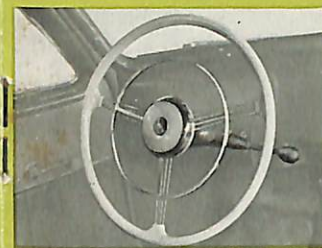

Effort Saving New Ross Cam and Lever Steering



Full Front Seat Model A-5



256 Adjustment Drivers Seat — A-4 Taxi Cab

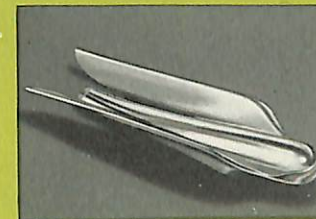

New Hood Ornament



Heavy Duty Battery—Model A-5

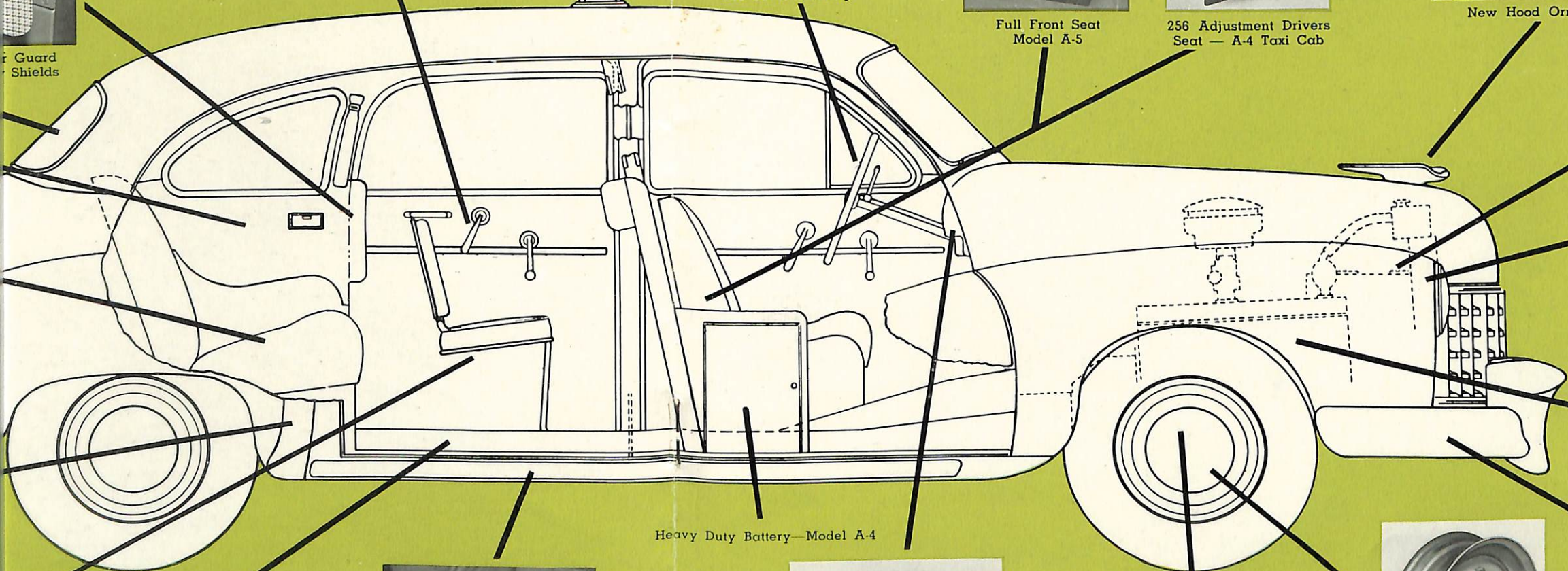

25% Greater Cooling Capacity



45-Amp. Heavy Duty Generator



Non-slip Blue-Moresque Floor Mats



Full-length Chrome Rub Rail Fender to Fender

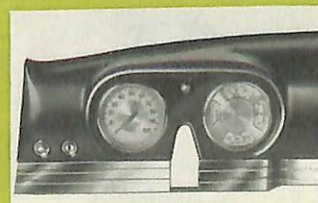

New Flush Instrument Panel with flush controls, and Tell-Tale Lite, signals driver when Rear Doors are not closed.

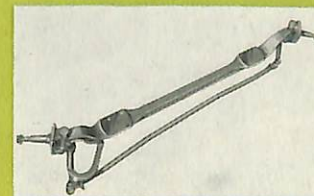

Full I Beam Type Front Axle



Balanced wheels with drop center type rims.



Greater Bumper Protection

small car outside
big car inside!

 *hoi* **SIZE**

The New Checker is designed to give the greatest usable space inside, ample to hold five forward riding adults in Model A-4 and 7 forward riding adults in Model A-5, driver and luggage. Yet outside dimensions are held to the minimum for safer driving in heavy traffic.

ROOMY COMFORT
makes passengers say,
"I'd rather ride in a Checker"

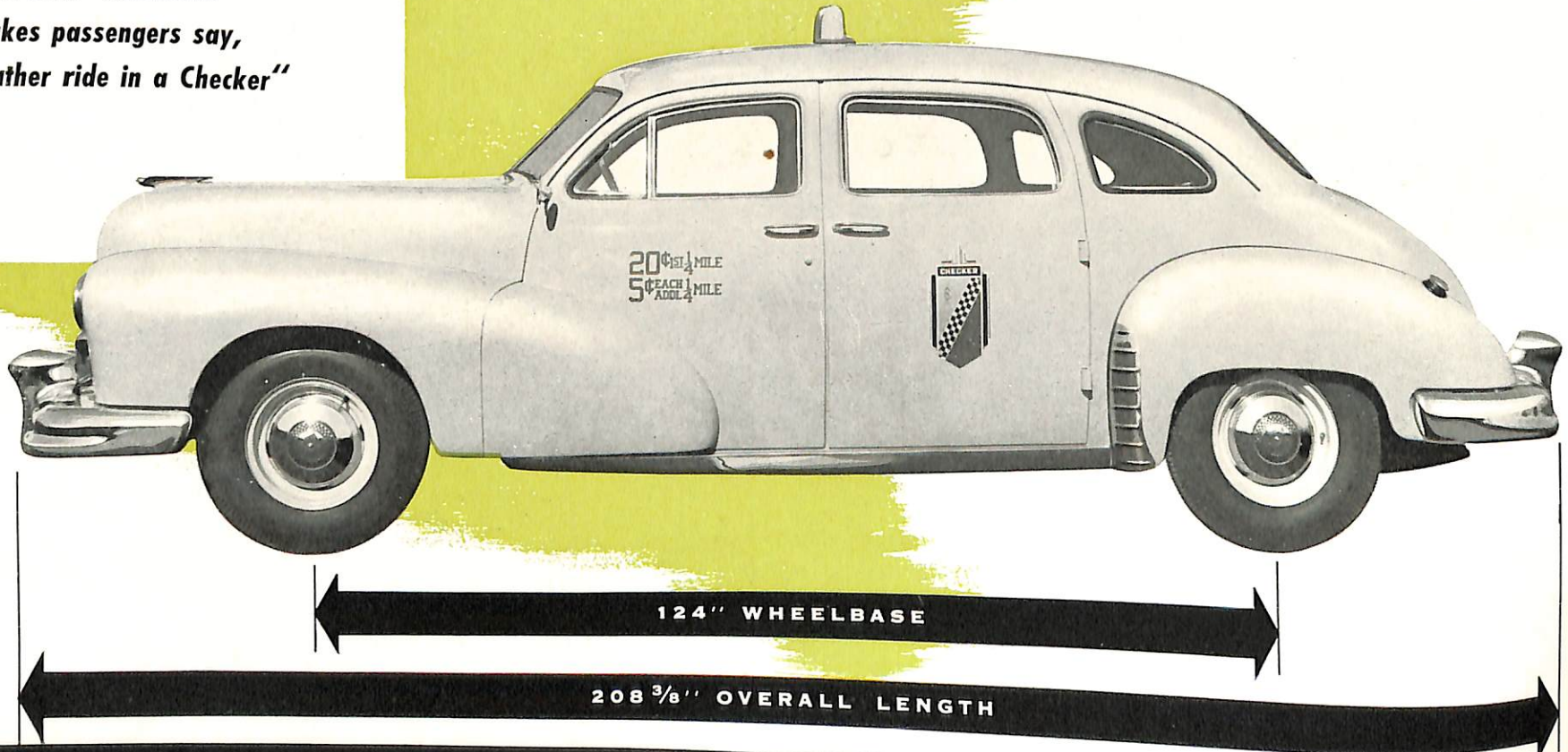
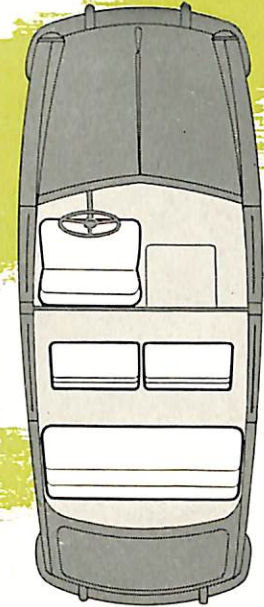
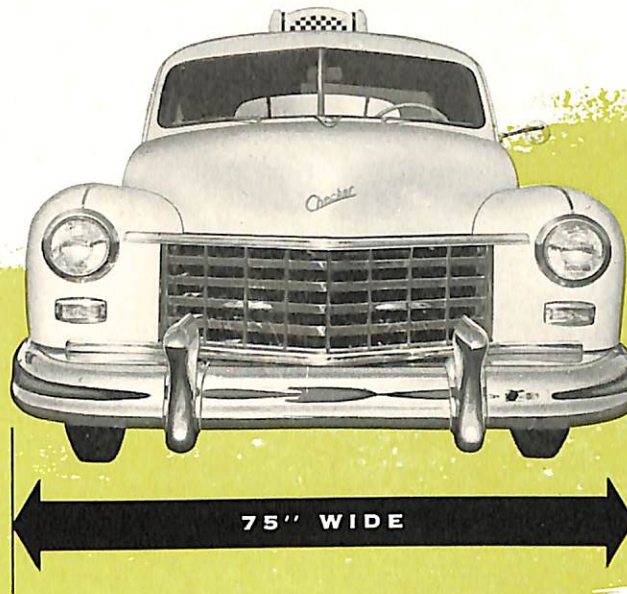

Checker Model A-5 is the same quality car as the Model A-4, with a completely redesigned interior to fit it for limousine service. Modern styling accentuates the smart, close-to-the-ground look. But underneath, the rugged Checker chassis is built to handle the full loads and steady going. The Checker Model A-5 is ideal for limousine type taxi service or hotel, airline and resort service.

The 1950 Checker

a beautiful
practical limousine

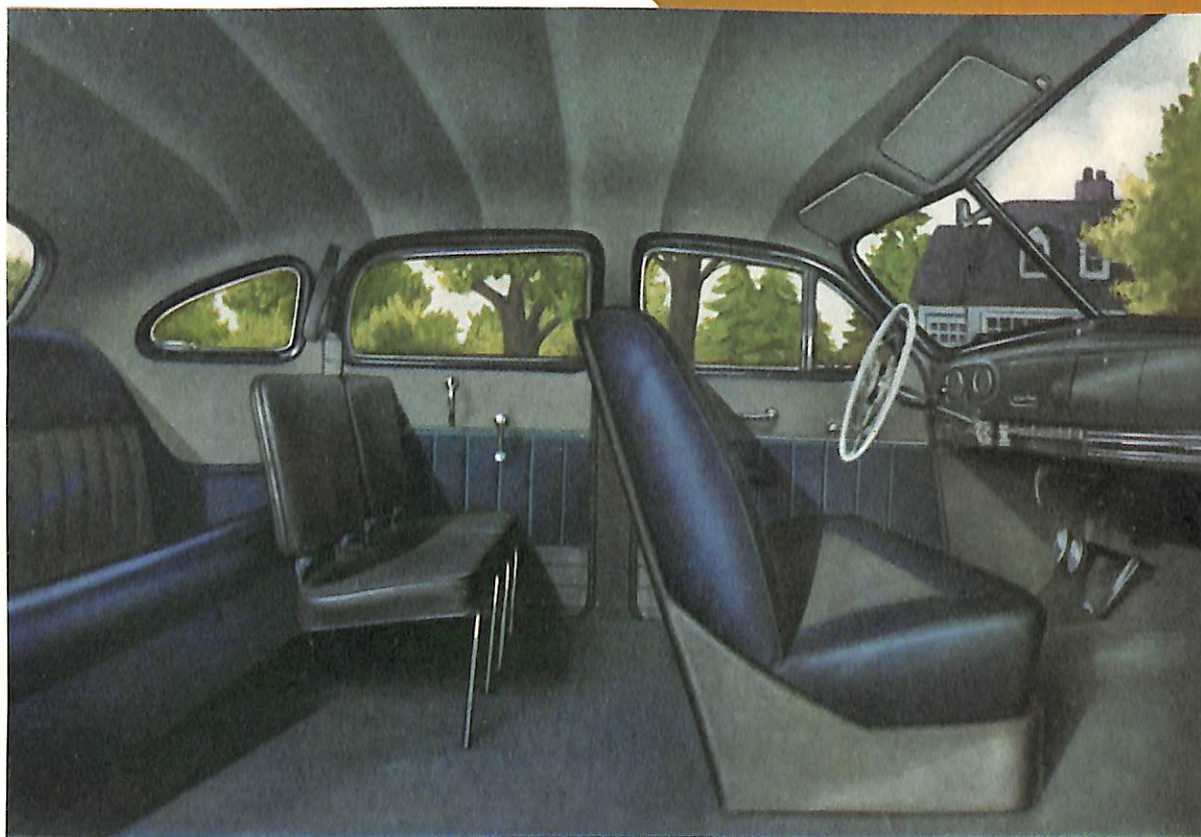
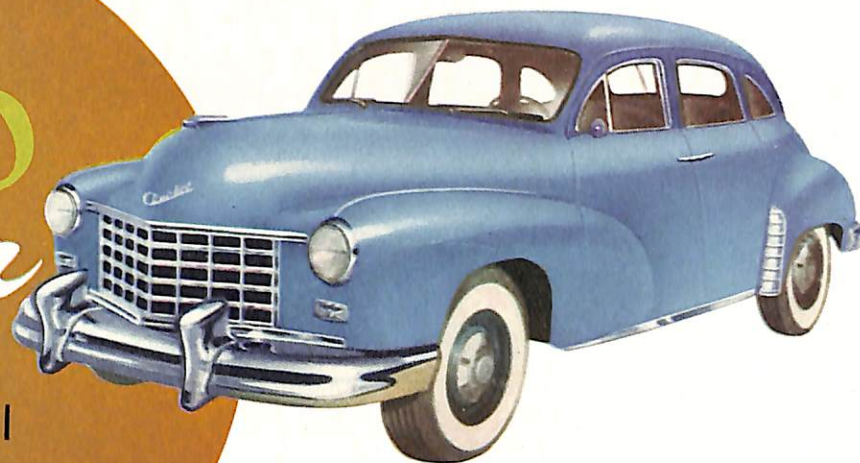

Unexcelled for luxury, appearance and practical design, the roomy interior of the Model A-5 provides comfortable transportation for as many as seven forward riding adults. And there is a spacious rear compartment for luggage.

The front seat is fully adjustable. Front and rear seats are foam rubber cushioned and covered with handsome plastic upholstery that can be cleaned with soap and water. Large air conditioner heater drawing in fresh air insures cold weather comfort and for hot weather or warm climates, the new ventilating rear window, combined with the air conditioner, assures thorough air circulation and maximum cooling. Twin duct defrosters completely eliminate inside frosting of windshield and windows.

Profits go **UP**...

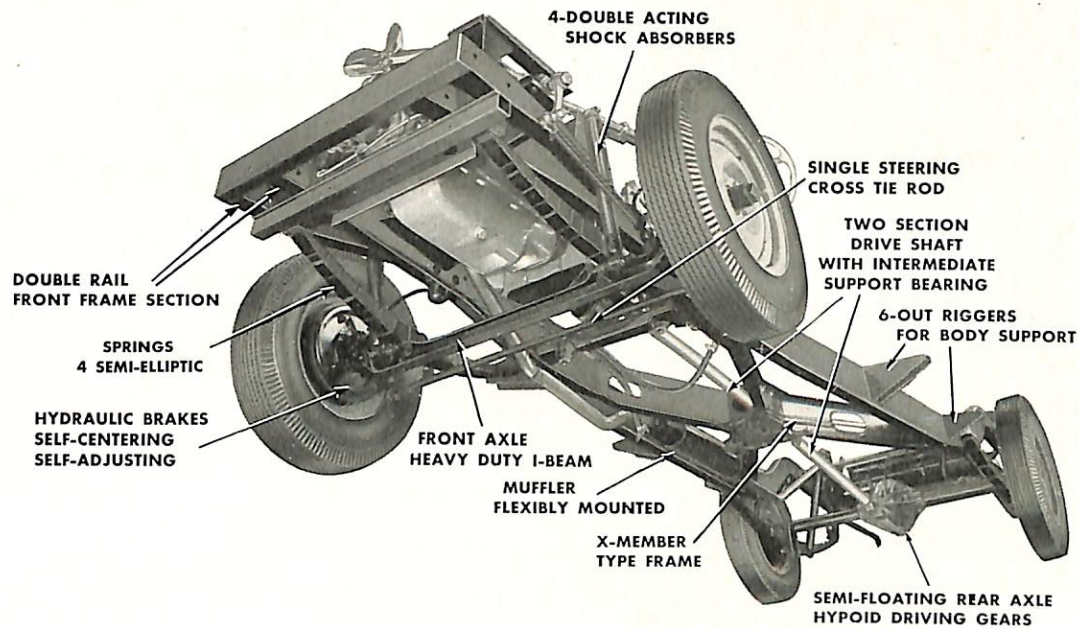

RUGGED CONSTRUCTION

Checker reduces out of service time, because the long life is built in. The Double Rail Front Section, Box Section Side Rails, the X-Member Type Frame, the Body Outriggers — all contribute to the strength of the complete structure.

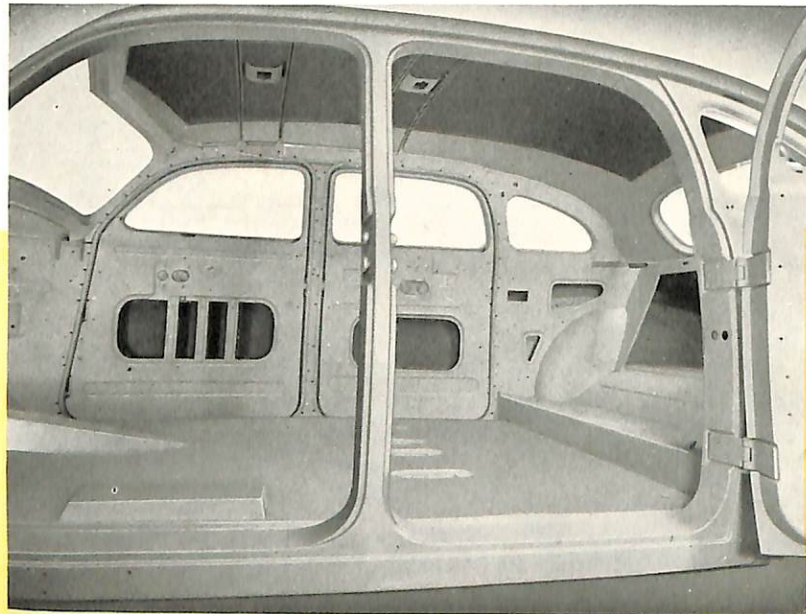

MONOCOQUE BODY — The frame, girders, sides, top and floor are all welded into a single, substantial unit. This construction is rigid, strong, safe, and reduces the possibility of body noise.

X-MEMBER FRAME—Sturdily cross-braced frame relieves twisting strains. X-members are welded into a box section at center.

PROPELLOR SHAFT—Needle bearing type made in two sections. Center support ball bearing is mounted at the X-member in rubber pillow block. Means less shaft "whip" and longer rear axle life. Permits lower rear floor without a hump.

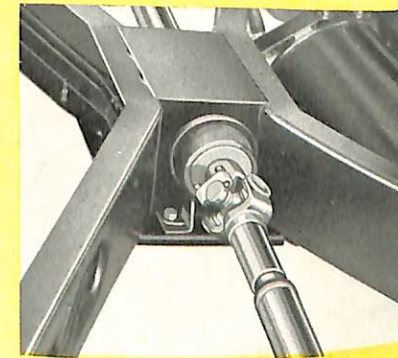
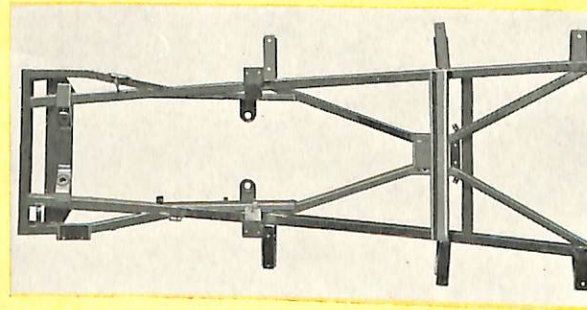

maintenance costs come **DOWN**

FOR *thrifty* OPERATION

Long, flat, semi-elliptic leaf type springs are used front and rear. In addition all four wheels are fitted with double-acting telescoping type shock absorbers to assure passenger comfort, and a smooth riding, smooth handling cab.

FORWARD MOUNTING—
Power plant and transmission are centered over the front axle giving passenger load the desirable between-the-axles ride.

HORSEPOWER TO SPARE—
Dependable engine develops maximum power at low speeds for maximum fuel economy. Accessories and fittings located for quick service or easy replacement.

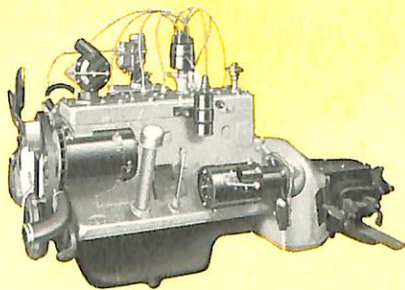
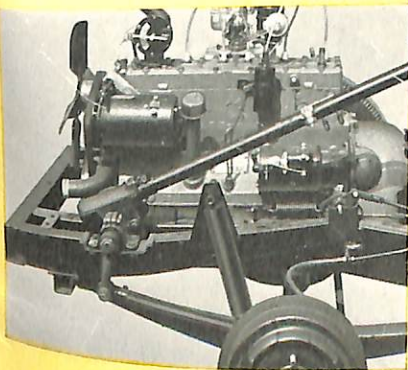

Specifications

of the Thrifty 1950 Checker Models A-4 and A-5

GENERAL

Wheelbase	124"
Overall length, bumper to bumper	208 ³ / ₈ "
Turning radius, right and left	20'
Tread front	60"
Tread rear	62 ¹ / ₂ "
Shipping weight	3950 lbs.

TRANSMISSION

Warner Gear, latest type, three speed. Synchronesh type shift on second and third drive. Operation of shift is through lever on steering column under wheel.

ENGINE

Continental precision-built 6-cylinder, L-head type. SAE rated HP 26.3. Silent chain cam shaft drive.

CLUTCH

Borg and Beck 10" diameter with special thermoid heavy duty woven asbestos facing.

REAR AXLE

Spicer semi-floating type. Hypoid ring gear and pinion with two pinion differential mounted on Timken bearings. Ratio 4.09 to 1 — other ratios optional.

BRAKES

Wagner hydraulic, self-centering, self-adjusting shoes automatically adjust to compensate for lining wear.

SUSPENSION

With power plant placed over the front axle the weight distribution with passenger load is evenly balanced between front and rear wheels. The passengers ride between the axles. This permits using springs with rates which give "flat ride."

FRONT AXLE

Reversed Elliot Type Main Beam S.A.E. 1040 steel heat treated. Full front axle

provides constant front end alignment resulting in greatly increased front tire wear.

WHEELS

Budd Steel balanced with drop-center type rims, either 15" or 16".

TIRES

6.50—16, 6-ply balloon type, front and rear.

PROPELLER SHAFT

Spicer needle bearing type made in two sections with center support ball bearing, mounted in rubber at X-member. This permits a lower flat floor with no tunnel.

STEERING GEAR

New, effortless roller mounted Ross cam and twin lever type. Steering wheel, 17" diameter.

OPTIONAL EQUIPMENT at extra cost

Winter-front — maintains coolant at uniform temperature. Overdrive. White side wall tires.

FEATURE EQUIPMENT at no extra cost

Tell-Tale Light mounted on dash to signal when rear doors are not closed.

Back Up Buzzer signals when vehicle is in reverse gear.

Vent-Alarm signal warns when gasoline tank is full.

Choice of 6.50—16, 7.00—15 standard tires or 7.60—15 low pressure tires.

“CHECKER” builders of taxicabs since 1922

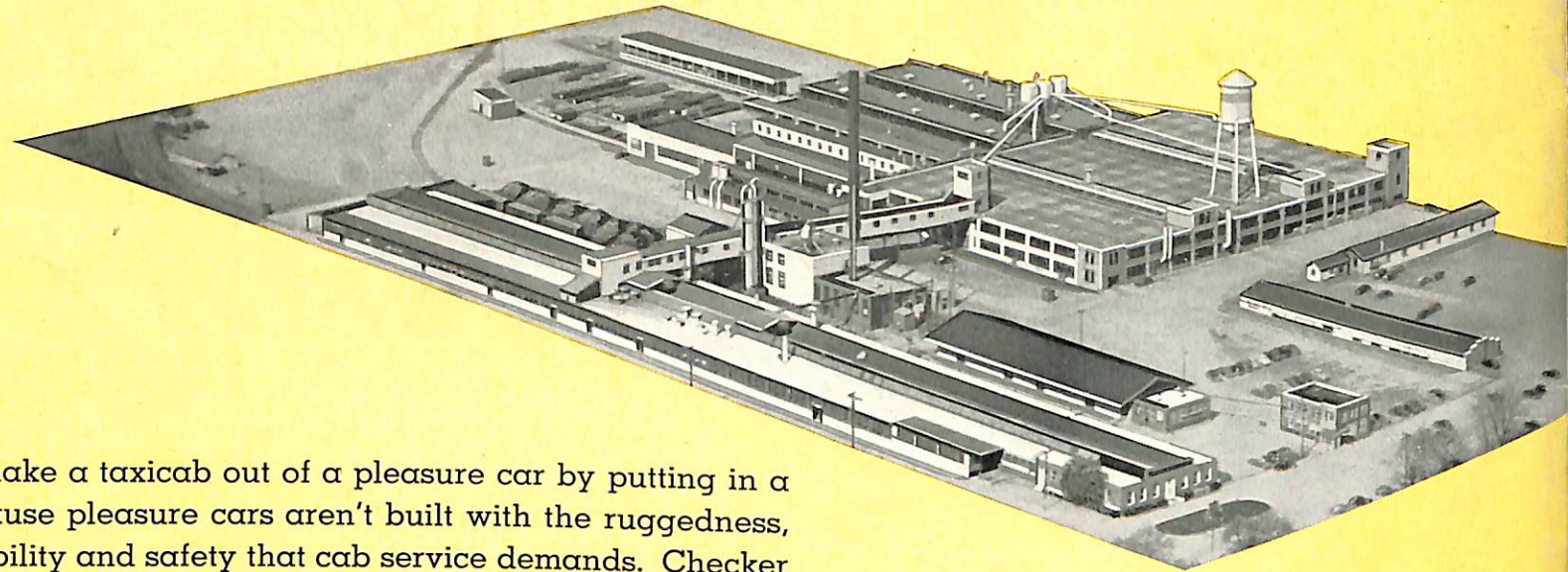

You can't make a taxicab out of a pleasure car by putting in a meter. Because pleasure cars aren't built with the ruggedness, maneuverability and safety that cab service demands. Checker is the *only* cab, with all these important features, built especially for tough urban service. It is designed for taxi service. It is built for taxi service. As a result, Checker has none of the shortcomings existent in conversion packages.

For profitable Taxicab operation, your best buy is CHECKER

ARISTOCRATS IN THE TRANSPORTATION FIELD

world famous
CHECKER TAXICABS

nationally known
TRANSIT BUSES

MANUFACTURED BY

CHECKER CAB MFG. CORP., KALAMAZOO, MICH.

