

# CHECKER MARATHON BEING PRACTICAL IS NEVER OUT OF STYLE.

**It's functional.**

**It's spacious. It's sensible.**

It's built for the comfort and economy of its owner. You enter through our doors without folding yourself in half. You sit in rich vinyl interiors available in a wide variety of colors.

You drive into a service station without trembling at the sight of the gas pump.

And, you drive with the security of knowing that the automobile you are driving was designed for the toughest, most demanding, most intensive kind of fleet driving—the taxicab.

Some cars are tributes to conspicuous consumption.

The Checker is a tribute to the common sense of its owner.



**CHECKER  
MOTORS  
CORPORATION**

Kalamazoo, Michigan 49007



# CHECKER MARATHON

## Why we make a lot more sense-- today and tomorrow.

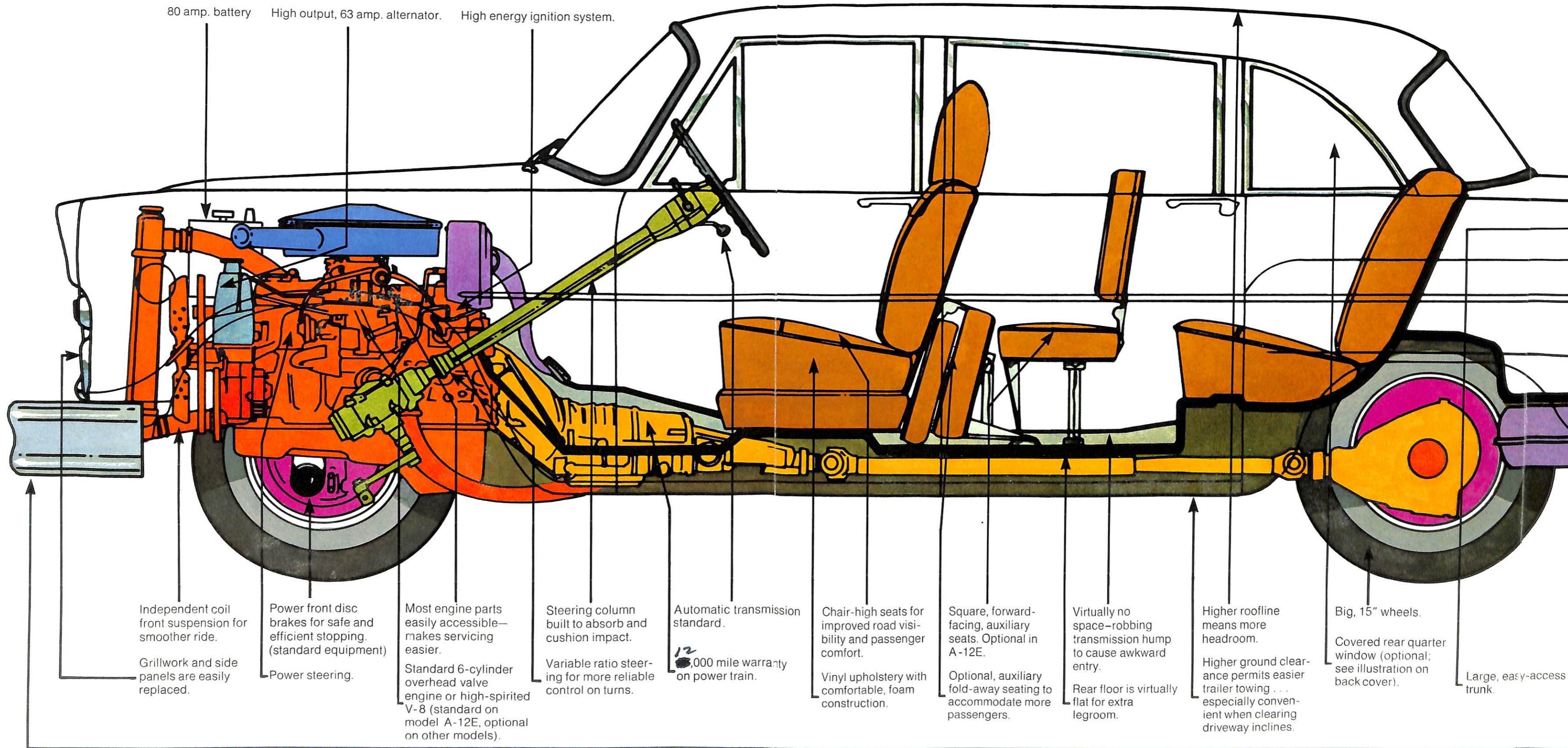

80 amp. battery    High output, 63 amp. alternator.    High energy ignition system.

Independent coil front suspension for smoother ride.  
Grillwork and side panels are easily replaced.

Power front disc brakes for safe and efficient stopping. (standard equipment)  
Power steering.

Most engine parts easily accessible—makes servicing easier.  
Standard 6-cylinder overhead valve engine or high-spirited V-8 (standard on model A-12E, optional on other models).

Steering column built to absorb and cushion impact.  
Variable ratio steering for more reliable control on turns.

Automatic transmission standard.  
<sup>12</sup> 100,000 mile warranty on power train.

Chair-high seats for improved road visibility and passenger comfort.  
Vinyl upholstery with comfortable, foam construction.

Square, forward-facing, auxiliary seats. Optional in A-12E.  
Optional, auxiliary fold-away seating to accommodate more passengers.

Virtually no space-robbing transmission hump to cause awkward entry.  
Rear floor is virtually flat for extra legroom.

Higher roofline means more headroom.  
Higher ground clearance permits easier trailer towing... especially convenient when clearing driveway inclines.

Big, 15" wheels.  
Covered rear quarter window (optional; see illustration on back cover).

Large, easy-access trunk.

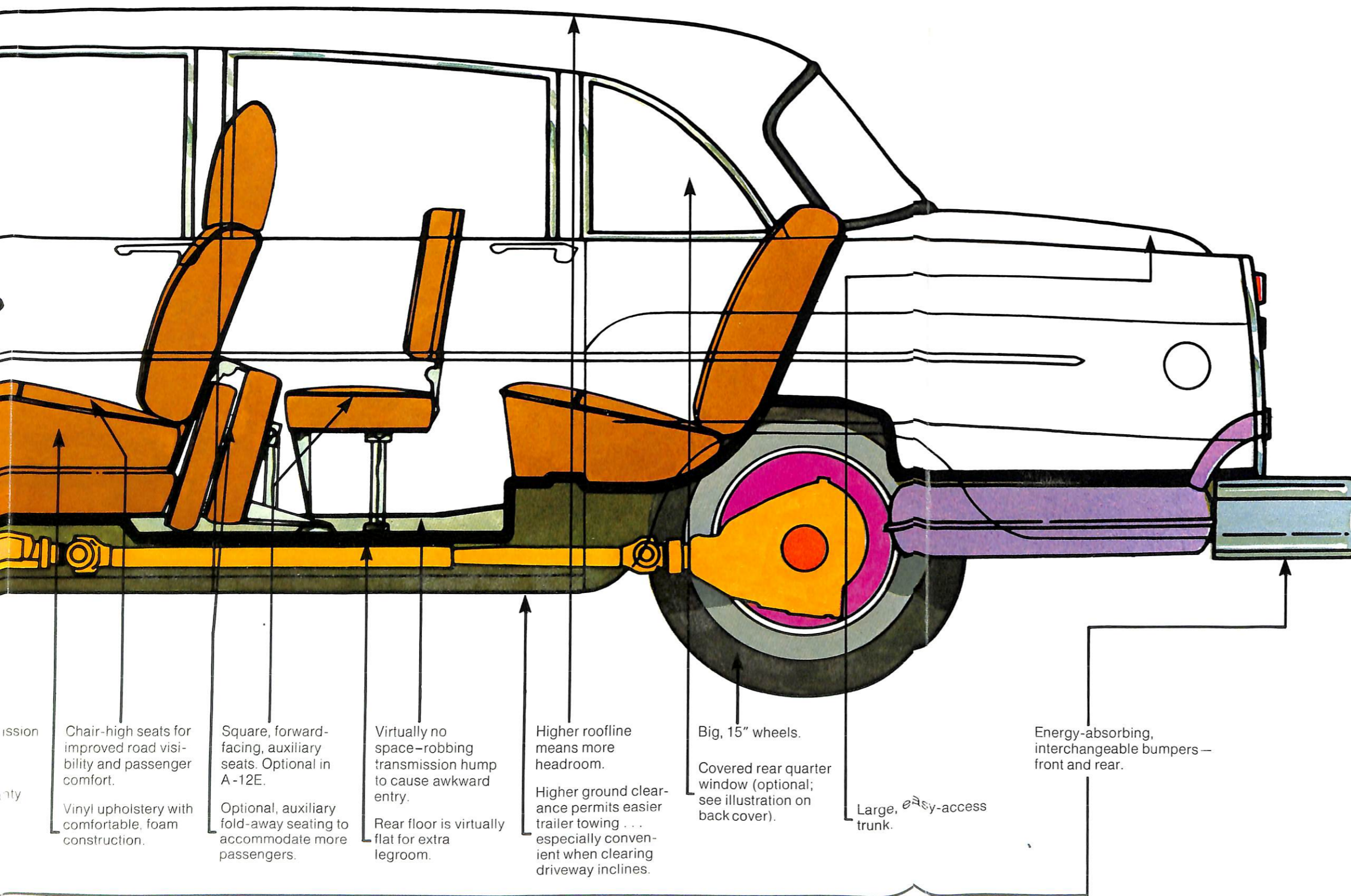

Some auto makers have made practicality a luxury by ignoring it. If so, the Marathon is one of the most luxurious cars on the road.

The Marathon reflects the way you feel about transportation. Dependability, comfort and reliability are the prime objectives.

Look at the Marathon from the inside out—comfortable seats that support, not coddle. There is a spacious feeling in back; *real* room so that you can stretch out and make travel a pleasant experience. There is no huge hump in the middle or the rear floor to bring your knees up to your chin.

You will find a distinctive kind of comfort in the smooth ride that has been engineered into every car bearing the Checker insignia. You'll even feel more comfortable driving into a gas station. The Marathon gets the kind of gas mileage that oil company executives don't like to think about.

The Marathon is engineered for both value and convenience. Automatic transmission, independent coil front suspension, power front *disc* brakes and power steering are all standard; a better purchase value—a better idea when you trade. Body parts like fenders, grillwork and side panels can be replaced with a minimum amount of time, trouble and expense.

In today's world of short cuts and cutting corners, it's good to know that Checker builds cars that make a lot of sense—today and tomorrow.

# CHECKER MARATHON

## Why we make a lot more sense-- today and tomorrow.

80 amp. battery

High output, 63 amp. alternator.

High energy ignition system.

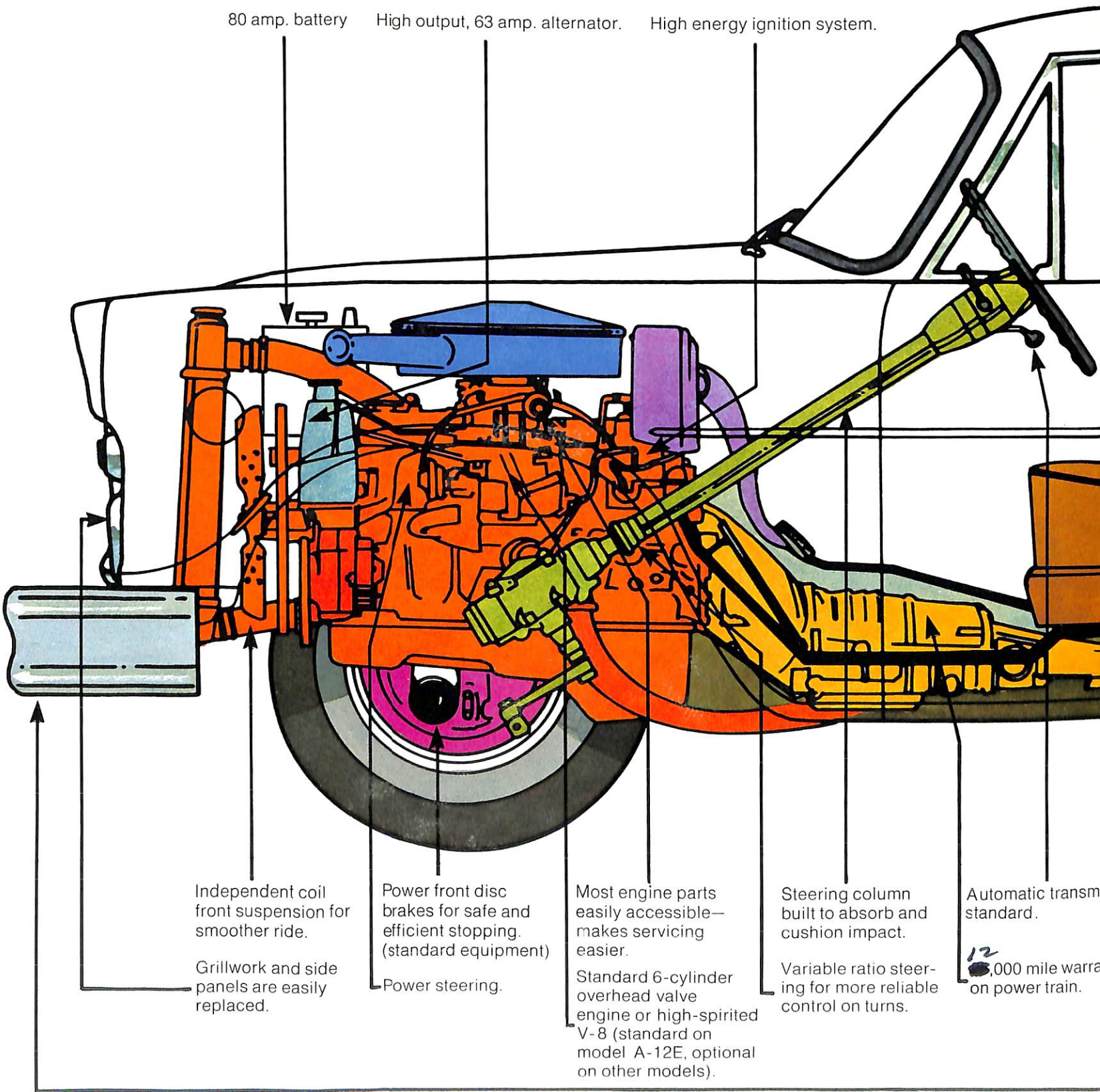

Independent coil front suspension for smoother ride.

Grillwork and side panels are easily replaced.

Power front disc brakes for safe and efficient stopping. (standard equipment)

Power steering.

Most engine parts easily accessible—makes servicing easier.

Standard 6-cylinder overhead valve engine or high-spirited V-8 (standard on model A-12E, optional on other models).

Steering column built to absorb and cushion impact.

Variable ratio steering for more reliable control on turns.

Automatic transmission standard.

12,000 mile warranty on power train.

# ION

more sense--

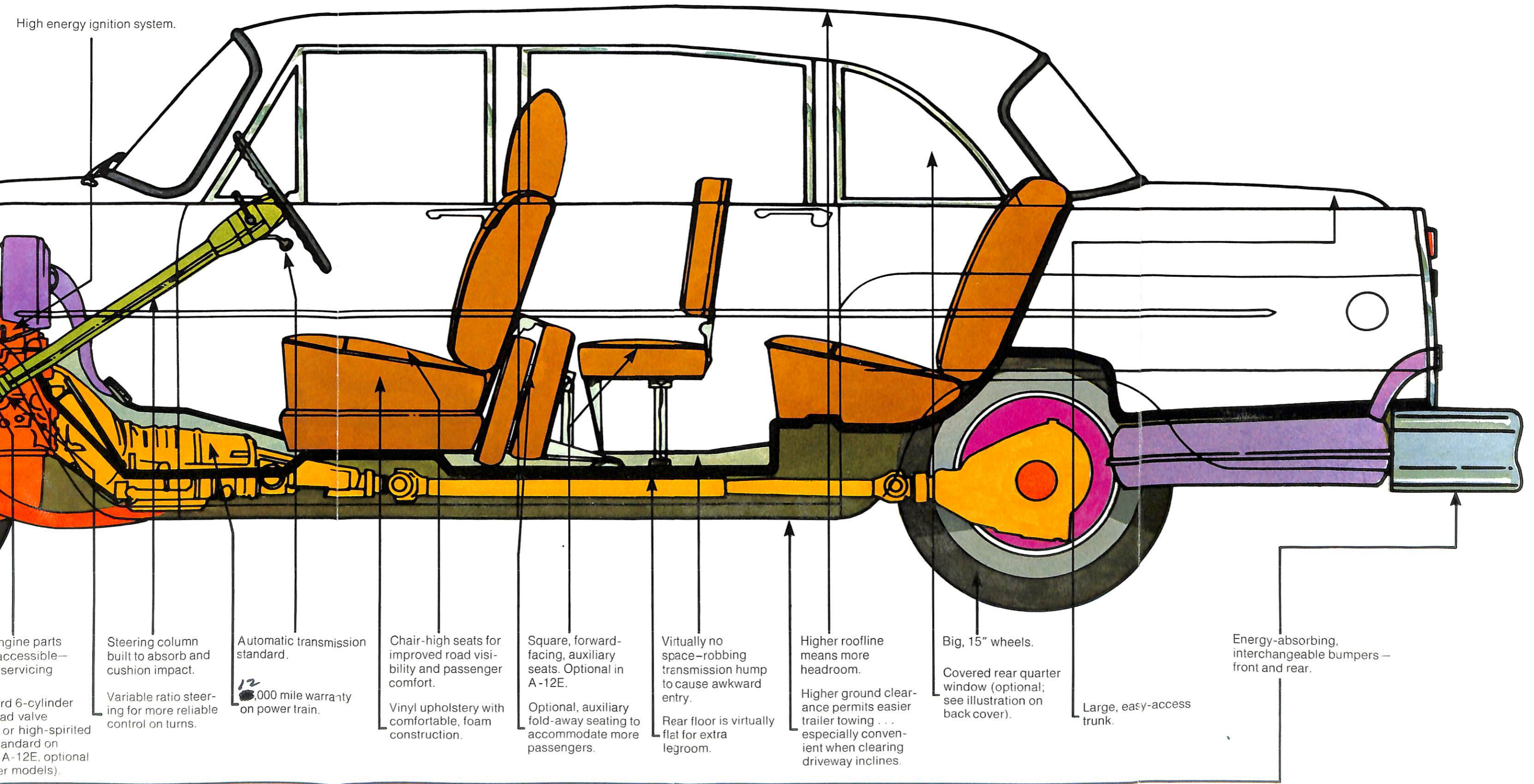

rd 6-cylinder  
ad valve  
or high-spirited  
andard on  
A-12E, optional  
er models).

Steering column built to absorb and cushion impact.

Automatic transmission standard.

12,000 mile warranty on power train.

Chair-high seats for improved road visibility and passenger comfort.

Vinyl upholstery with comfortable, foam construction.

Square, forward-facing, auxiliary seats. Optional in A-12E.

Optional, auxiliary fold-away seating to accommodate more passengers.

Virtually no space-robbing transmission hump to cause awkward entry.

Rear floor is virtually flat for extra legroom.

Higher roofline means more headroom.

Higher ground clearance permits easier trailer towing... especially convenient when clearing driveway inclines.

Big, 15" wheels.

Covered rear quarter window (optional; see illustration on back cover).

Large, easy-access trunk.

Energy-absorbing, interchangeable bumpers—front and rear.

# CHECK A CHECKER FROM THE INSIDE OUT.

1. The extra-high doors open fully to give passengers easy entrance and exit. Step in and out without folding yourself in half.



2. "No hump in back" allows for greater legroom, more headroom, and more passenger comfort. More space for packages, bundles and other "carry-on's," too.

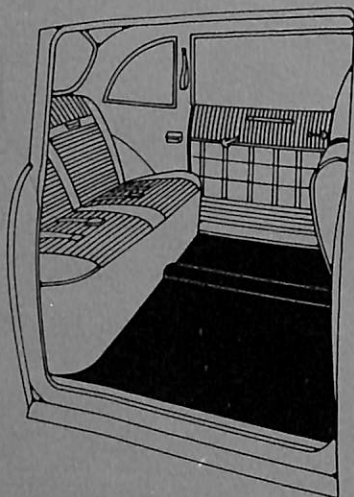

3. Spacious interiors are a Checker trademark. Opulent legroom combined with wide, comfortable seating gives a limousine-like ride that's difficult to find in any other car.

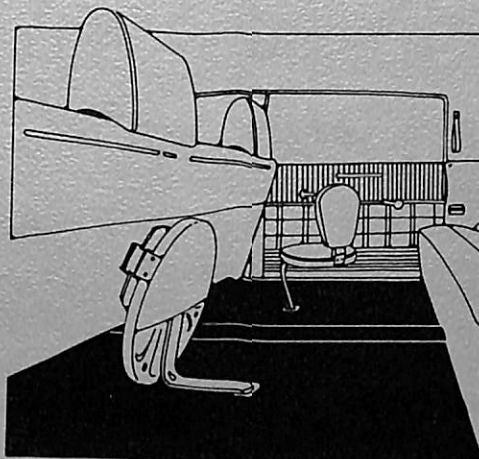
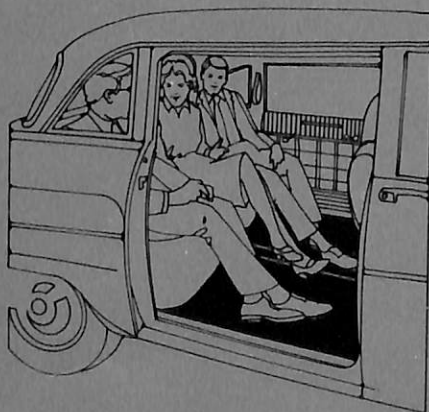

4. Optional, auxiliary seating is available to accommodate up to five passengers in comfort. They fold down and out of the way when not in use.

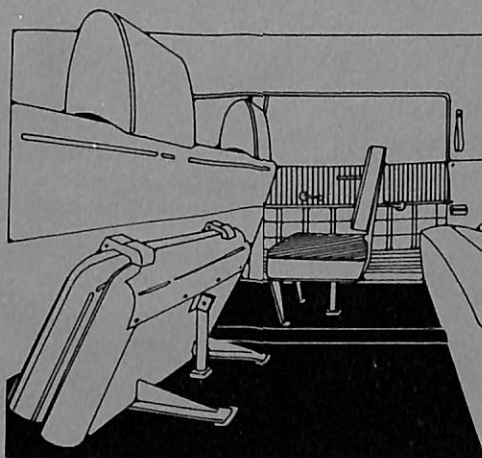

5. Square, forward-facing auxiliary seats are available in A-12E as an option. Allows for up to six passengers in rear compartment.

# THE ULTIMATE CHECKER THE MARATHON A-12E

Regally simple, of classic dimensions, the A-12E provides the proportions of a limousine without the ostentation or expense. The 129-inch wheelbase supports an automobile that can accommodate forward-facing auxiliary, optional seats in the rear compartment for six-in-back seating with comfort.

267

• CID V-8, automatic transmission, power front disc brakes, power steering are standard equipment. A noble top-of-the-line automobile—understated in simplicity—unmatched in value.

Checker Motors Corporation reserves the right to change at any time, without prior notice, price, colors, materials, equipment, specifications, and models or to discontinue models without obligation to anyone including previous purchasers of current models. Some equipment and accessories illustrated are not standard equipment and will be furnished at extra cost if available.

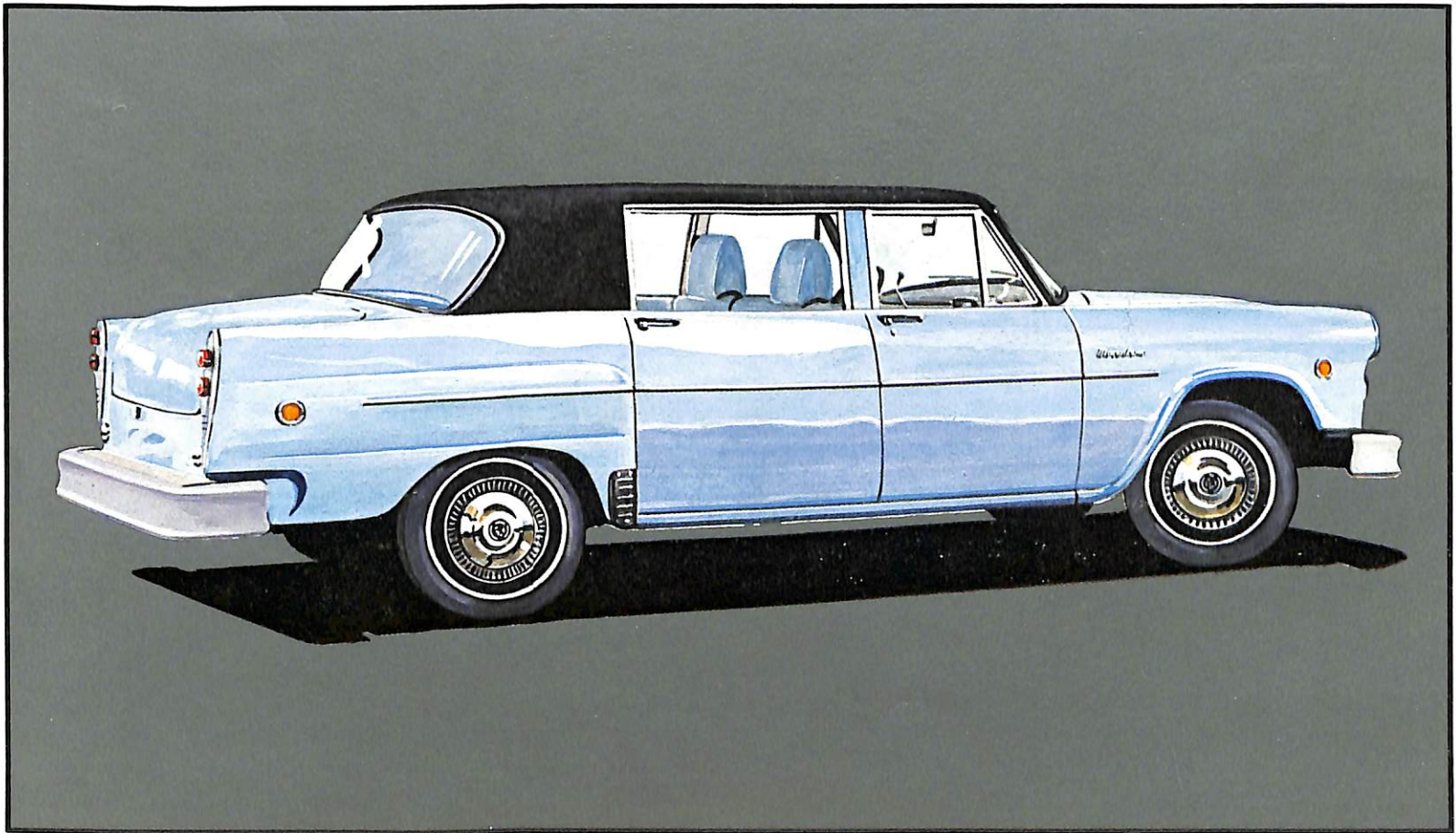

**CHECKER  
MOTORS  
CORPORATION**

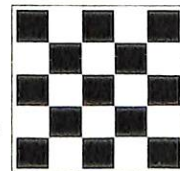

Kalamazoo, Michigan 49007