



POWER CORRUPTS.  
ABSOLUTE POWER CORRUPTS ABSOLUTELY.

In the Italian Renaissance the word for power was Machiavelli. In the second Italian Renaissance, the word is Maserati. Only Maserati would dare arm a V-6 passenger car engine with the same twin turbos found only on Formula One race cars. While lavishing the cockpit with racing



instrumentation and handstitched leather appointments befitting a driver of neo-Medici aspirations. Result? The Maserati Spyder convertible, a mating of absolute power and absolute luxury. Under \$32,000, plus state and local taxes. The second Italian Renaissance has begun.

THE ITALIAN TRADITION.

For a test drive at a Maserati dealership, call 301-646-3630, East. Or 415-775-3721, West.



## TECHNICAL DATA

### Engine

Position		front
Cylinders	No.	V-6 at 90°
Bore	mm	91.6
Stroke	mm	63
Cubic capacity	cc	2491
Compression ratio		7.7:1
Maximum torque	kgm	31 at 3200 r.p.m.
Maximum power	HP	185 at 5500 r.p.m.
IHI turbochargers water cooled	No.	2

Engine block and head in light alloy with pressed-in wet liners; water cooling by centrifugal pump; forced lubrication and total filtering; one twin carburetor, two overhead camshafts; three valves per cylinder (two intake valves and one exhaust valve). Electronic ignition; 65 AMP alternator

### Gearbox

Automatic 3

Ratios:

I = 2.48

II = 1.48

III = 1.00

REV = 2.09

Rear wheel drive

Differential box: Salisbury type, with Sensitork®

Axle ratio: 3.31:1

Chassis: unitized body & chassis

**Suspensions:** front suspension type Mac Pherson with stabilizing bar and double-acting telescopic shock-absorbers. Rear suspension of the type with independent arms fixed to a crosspiece anchored to the body by means of elastic mounts with coil springs and double-acting telescopic shock-absorbers

**Steering:** Power steering

**Braking system:** IH type A.T.E. with servocontrol  
Disc brakes on all four wheels + two rear drum brakes for emergency and parking

**Wheel rims:** light alloy 6½"

**Tires:** 205/55 VR 14 - 195/60 VR 14

**Body:** three-box spyder - 2 + 2 seats

## DIMENSIONS AND WEIGHTS

Wheel base	mm	2400
Front track	mm	1442
Rear track	mm	1453
Length	mm	4055
Width	mm	1714
Height	mm	1305
Minimum height from ground	mm	125
Dry weight	kg	1086
Fuel-tank	litres	82
Luggage compartment	dm³ approx.	550
Turning circle	m approx.	11.70

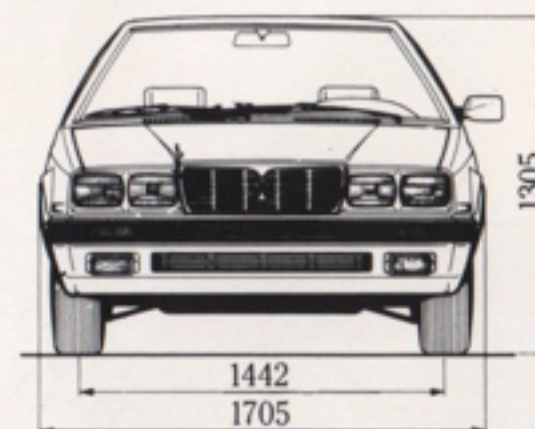
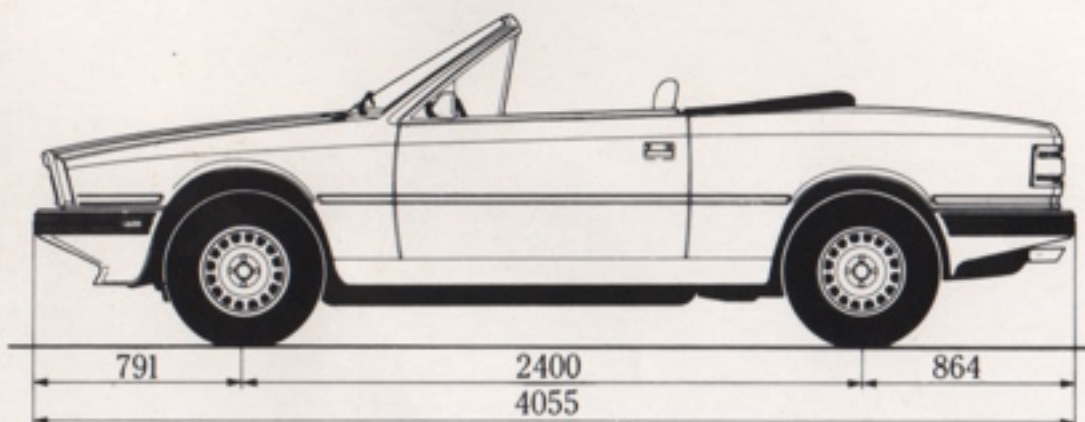
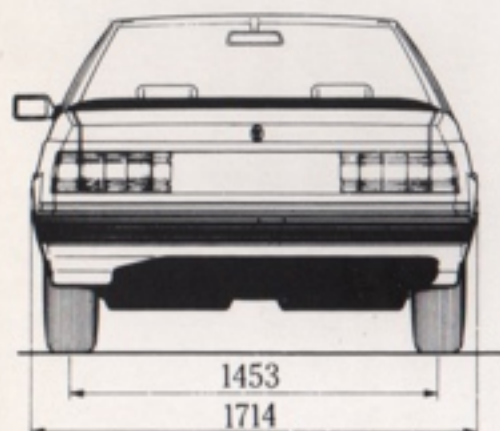

## ACCESSORIES

- Power steering
- Steering wheel lock
- Vertical and longitudinal adjustment of steering wheel
- Seat back tilting power switch
- Electronic ignition
- Headrests on front seats
- Safety rear view door mirror adjustable from inside
- Analogic clock
- Sensitork® differential
- Open door safety lights
- Air conditioning system with additional distribution of air to rear seats and side windows
- Light alloy wheels
- Low beam height adjuster from inside
- Fog lights
- Electrically operated side windows
- Tinted glass
- Radio and speakers prearrangement
- Back lights
- Safety belts of inertia reel/autoretracting type for front seats
- Hand sewn leather seat facings