



DTS



2006 CADILLAC DTS

DTS





DTS

EVOLUTION

Spacious, luxurious and possessed of a unique presence, full-size Cadillac sedans have long been the cars of choice for celebrities, heads of state and high achievers everywhere. Now for 2006, a new full-size Cadillac takes the spotlight. DTS embodies the spirit of today's Cadillac in its crisp styling, cutting-edge technology, refined V8 performance and a vast array of premium amenities. At the same time, DTS carries on the finest of Cadillac traditions, with the roomiest interior of any Cadillac sedan and a driving feel that's at once relaxing and invigorating. The new DTS. It's the large luxury sedan at its most evolved.

INSPIRATION



CADILLAC DTS
BREAK THROUGH

For more information about DTS visit
our Web site at dts.gmcanada.com





GRACE

AN EXTRAORDINARY PRESENCE.

AND AN EXTRAORDINARY EXPERIENCE.



STRENGTH

From the moment you first see the new DTS, its presence is unmistakable. Measuring well over five metres from bumper to bumper, DTS is one of the largest sedans on the road today. This impressive stature is accentuated by elegant geometric shapes, sweeping horizontal lines and crisp intersections. DTS is also replete with bold details that reward closer inspection, including such Cadillac trademark touches as vertical headlights, fast-illuminating LED tail lights, a full-width LED centre high-mounted stop light and sculpted alloy wheels. It's worth noting, too, that the DTS body is as seductive to the wind as it is to the eye. Its aerodynamic drag measures a low 0.32, which results in improvements in performance, fuel efficiency and interior peace and quiet.

SLEEK

EVEN THE WIND IS SEDUCED.

EFFICIENT



Extraordinarily close tolerances of 2 mm (0.08 in.) (between tail light and deck lid) help reduce wind noise, as do structureless wiper blades. While laminated front and rear moveable side glass aids in keeping residual high-frequency whistling from entering the cabin. In all, they tame unwanted disturbances.

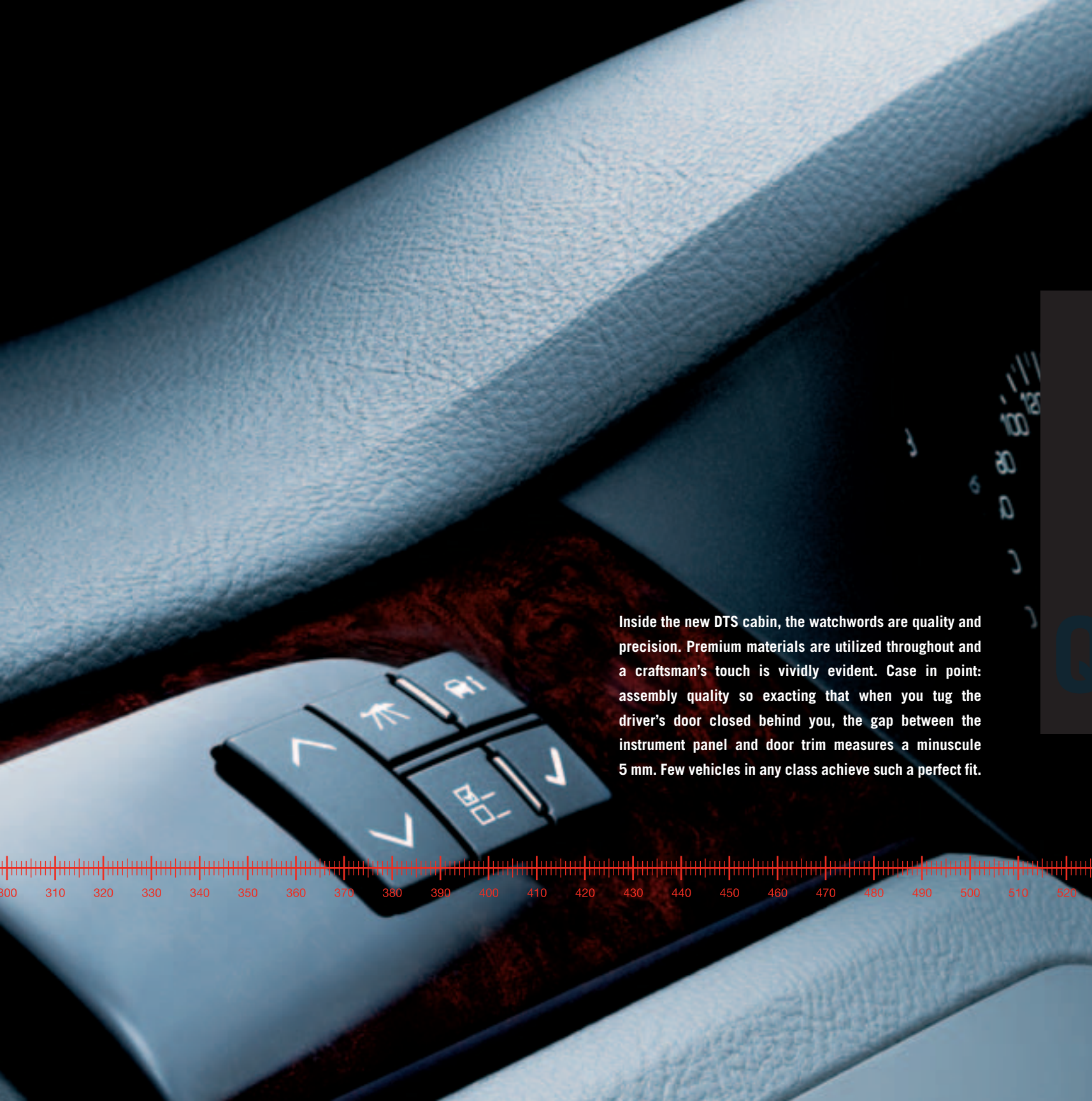

Inside the new DTS cabin, the watchwords are quality and precision. Premium materials are utilized throughout and a craftsman's touch is vividly evident. Case in point: assembly quality so exacting that when you tug the driver's door closed behind you, the gap between the instrument panel and door trim measures a minuscule 5 mm. Few vehicles in any class achieve such a perfect fit.

QUALITY

A PERFECT FIT.

QUIET







SPACIOUS

ENJOY THE RIDE OF A LIFETIME.

HUSHED

CONVENIENT

ELEGANCE AND CONTROL AT
YOUR FINGERTIPS.

INTUITIVE

For an example of Cadillac's unrelenting attention to detail, look no further than the DTS steering wheel. The standard tilt adjustable wheel is elegantly designed with a substantial, leather-wrapped rim and convenient, hub-mounted switches for the audio and cruise control systems. For the ultimate in style and comfort, a heated wood and leather-trimmed wheel with power tilt and telescopic adjustments is also available.

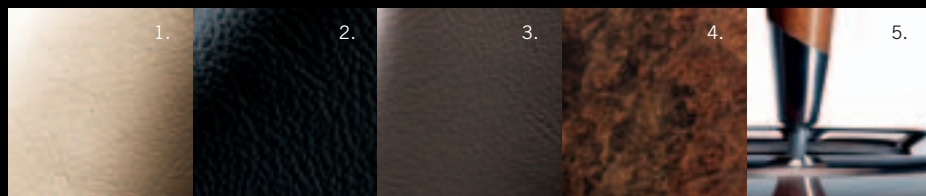

Fine materials make the DTS passenger compartment a delight for you, your family, your friends and your colleagues. Chrome and aluminum accents abound. Natural Burlled Walnut trim is available to adorn the instrument panel, console and doors. DTS also offers a choice of three different premium leathers – the most in any full-size luxury sedan – including available Teháma* aniline skins so supple, they're typically found only on the most exclusive home furniture.

1. Standard Nuance leather – Incorporates a soft-to-the-touch feel with a sandstone finish.
2. Available Tuscany leather – Semi-aniline, specially selected and tanned skins provide a rich feel.
3. Available Teháma* leather – Automotive aniline, naturally finished for a premium glove-like texture.
4. Available natural Burlled Walnut wood – With a distinctive grain and a warm natural colour.
5. Aluminum – With a lustre that contributes a warm, contemporary look to the DTS cabin.

Beneath the fine leather, DTS's seats are engineered for a superior level of driving enjoyment. The front buckets are power adjustable, ten ways. For optimal support for your lower back, power lumbar adjusters are standard on the front seats and available in the rear – a DTS exclusive in its class. The seat padding utilizes a dual firmness strategy that combines soft cushioning in the head and shoulder area with firm support in the cushion and lower seatback area for optimal long-distance support. Heated seats are available, as are seats that are both heated and cooled internally, assuring your comfort in every season.

*Interim availability, please see your Sales Consultant for more information regarding Teháma leather.

SUPPORT

A MOST FITTING SEAT.

ADJUSTABILITY

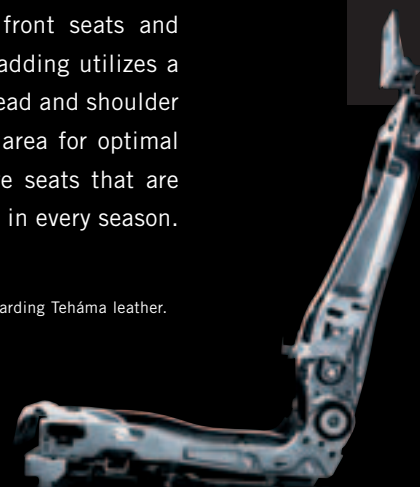

THOUGHTFUL

INTELLIGENCE AT WORK.

MEANINGFUL

Underlying the new DTS's exceptional performance, sophistication and refinement is a virtual catalogue of high-tech systems, all linked together by a state-of-the-art electronic architecture. The crucial component is a high-speed data bus that communicates at speeds up to 50 times faster than previous designs, ensuring the precise and timely coordination of the car's diverse systems. It's an intelligent application of cutting-edge technology that yields advances in control, safety, reliability and convenience.



PERFORMANCE COMMAND NETWORK

Links critical motion systems such as:

- 1 Engine control
- 2 Transmission control
- 3 StabiliTrak with anti-lock brakes
- 4 Integrated body control
- 5 GM Goodwrench Remote Diagnostics
- 6 Radar-based Adaptive Cruise Control.

PERSONALIZED CONTROL NETWORK

Coordinates vital control systems such as:

- 7 Climate controls
- 8 Driver Information Centre
- 9 Air bag safety diagnostics
- 10 IntelliBeam controller
- 11 Adaptive Remote Start
- 12 OnStar communications.

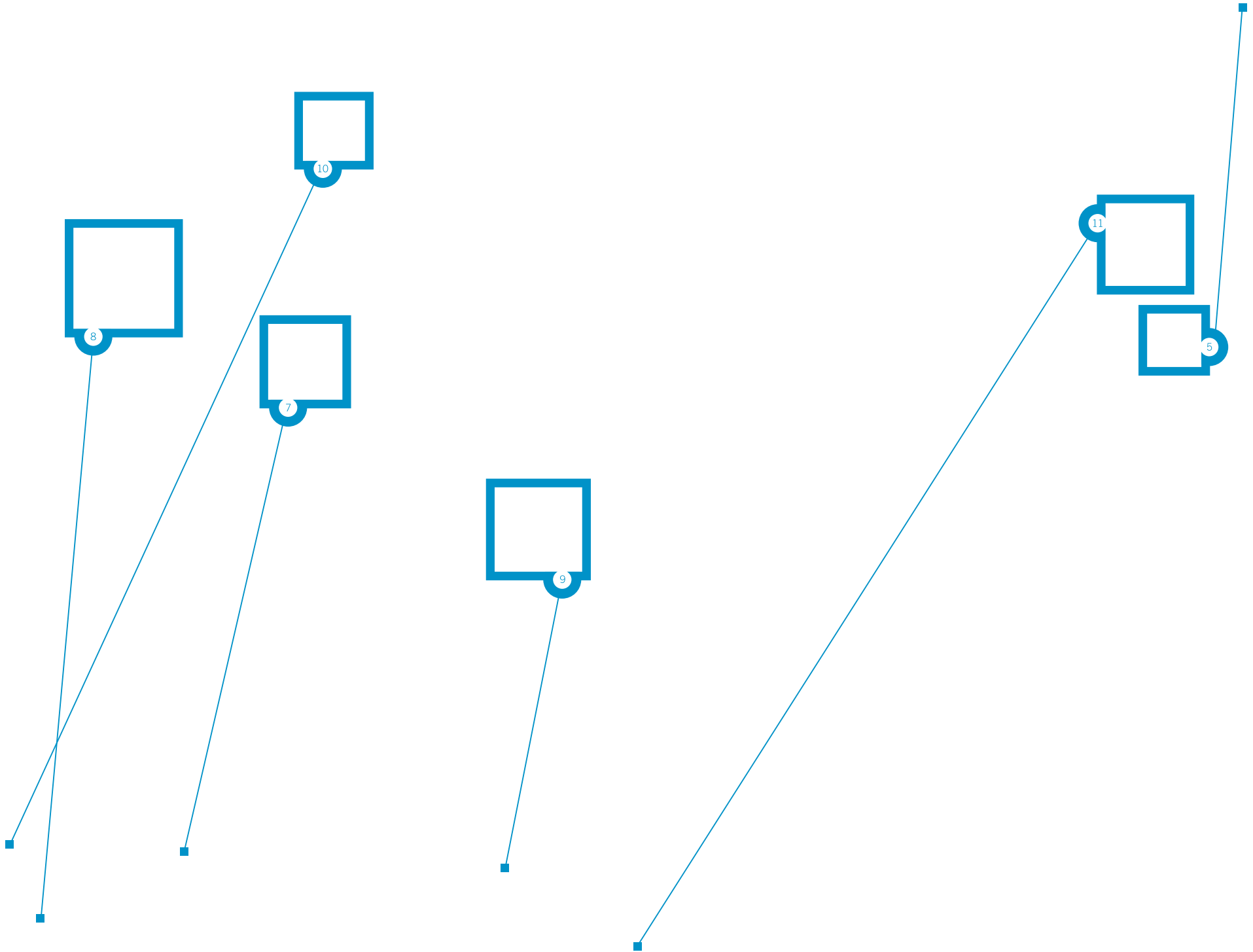

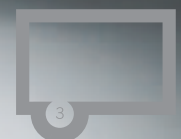

HIGH-TECH

**THE ONGOING EVOLUTION OF
DRIVING PLEASURE AND
CONVENIENCE.**

CONFIDENCE

Innovative new systems in your DTS will allow you to enjoy highway driving like never before. Take the available Adaptive Cruise Control (ACC), for example. It's a radar-based system that can actually sense when traffic appears ahead. Should a slower vehicle block your progress, the ACC will automatically slow your DTS and maintain a pre-set following distance. When the vehicle ahead turns off, or when you change to an open lane, the ACC will return your DTS to your preferred cruising speed. The available IntelliBeam headlight system offers a similarly advanced level of convenience. In traffic, it turns your high beams down, to avoid dazzling other drivers, and turns them up again when appropriate, to provide maximum illumination and safety.



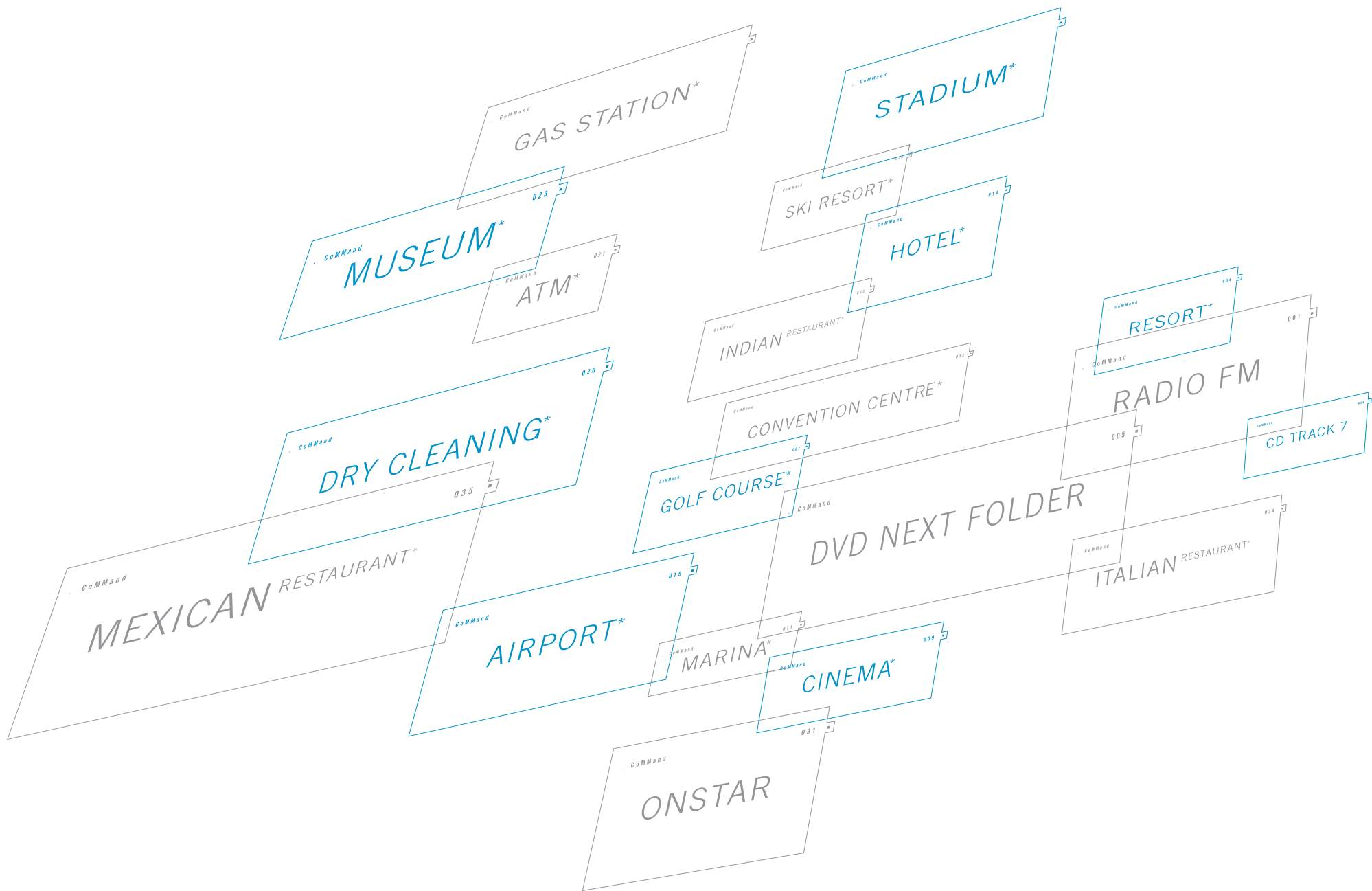

Why interrupt the pleasure of the drive to ask directions or pore over a map, especially when DTS's available DVD navigation system can act as your personal travel guide? With roughly 11 million kilometres of roadway stored in memory, it can guide you to destinations across Canada and the U.S.* For your convenience, the system includes a voice recognition feature that responds to your spoken commands. It can talk back, too, to provide you with detailed, turn-by-turn directions.



*At time of print, detailed map coverage is available for most major urban areas of the United States and for certain metropolitan areas of Canada (Vancouver, Calgary, Edmonton, Winnipeg, Windsor, London, Toronto, Ottawa, Montreal, Quebec City and Halifax). Coverage is significantly limited outside these areas. Choose the factory navigation option and you will receive an updated navigation DVD each of the first two years following your purchase.

CONVENIENCE

**READY WHEN YOU ARE –
OR BEFORE.**

SANCTUARY



On cold February mornings and blistering July afternoons alike, Adaptive Remote Start helps make your DTS's interior an even more inviting environment on your arrival. Simply touch the button on the fob from up to 60 metres (200 feet) away. Not only does the engine engage automatically, but so do the climate control system and, when appropriate, the defrosters and heated seats. By the time you arrive at your DTS's door, the cabin is well on its way to being a comfortable sanctuary from the weather outside.

To the ear, the new DTS is simply a delight. Unwanted noises are banished by a host of advanced features, including sound-absorbing steel and laminated side window glass. The sounds you do wish to hear, though, come through with a rare clarity, thanks to the superb standard audio system. It features a CD player, no fewer than eight premium speakers and an auxiliary input jack that allows you to entertain your passengers with music stored on your MP3 player.



SILENCE

HEAR PRECISELY WHAT
YOU WANT TO HEAR.

SOUND



no. 7/8

> ZONE

HEAD CURTAIN SIDE AIR BAGS*
REAR PASSENGERS

Helps protect head and neck from injury in certain side-impact collisions.
Covers all outboard seats.

GUARDIAN

ENGINEERED TO HELP YOU
BREATHE EASY.

SECURITY

In the finest Cadillac tradition, the new DTS has been designed and equipped to provide you with a degree of safety far beyond the ordinary. Particular attention has been paid to helping you avoid collisions of all kinds whenever possible. DTS's well-placed controls, excellent outward visibility and powerful four-wheel disc braking system all play their roles, as does the available front and rear Ultrasonic Parking Assist system that automatically alerts you when pets, children and other

objects are in your path at parking speeds. Other DTS features – including eight air bag protection zones, the most in DTS's class – help to protect you and your passengers should an impact prove unavoidable. Your DTS can even protect you after a crash has taken place. Should your air bags have deployed, the standard OnStar System will automatically alert an OnStar Advisor** who can dispatch emergency services to your location if necessary.

*Head curtain air bags are designed to help reduce the risk of head and neck injuries to front and outboard rear-seat occupants during certain side-impact collisions.

**Please refer to page 30 for more information regarding the OnStar System.

no. 1/2

HEAD CURTAIN SIDE AIR BAGS

DRIVER & FRONT PASSENGER

Helps protect head and neck from injury in certain side-impact collisions. Covers all outboard seats.

> ZONE

> ZONE

no. 5/6

SEAT-MOUNTED THORAX SIDE-IMPACT AIR BAGS

DRIVER & FRONT PASSENGER

Helps protect the mid-section of the body from injury in certain side-impact collisions. Covers all front outboard seats.

no. 3

DUAL-STAGE FRONTAL AIR BAG*
DRIVER

Helps protect chest, head and neck from injury in moderate to severe frontal crashes.

no. 4

AUTOMOTIVE-FIRST DUAL-DEPTH, DUAL-STAGE AIR BAG
FRONT OUTBOARD PASSENGER

Senses severity of event, safety belt usage and occupant seat position. Helps protect chest, head and neck from injury in moderate to severe frontal crashes.

*Always use safety belts and proper child restraints, even in vehicles equipped with air bags. Even with Passenger Sensing System, children are safer when properly secured in a rear seat. Never place a rear-facing infant restraint in the front seat of any vehicle equipped with an active frontal air bag. Refer to the Owner's Manual for more safety information.



AGILITY

**MAGNETIC RIDE CONTROL:
ACHIEVING AN
EXTRAORDINARY BALANCE.**

COMFORT

One tradition that DTS happily dispenses with is the age-old trade-off between ride and handling. With advanced magneto-rheological fluid in its shock absorbers, the available Magnetic Ride Control (MRC) suspension adjusts to road and driving conditions up to 1000 times per second. The result: comfortably controlled ride motions and a kind of handling agility you may find astonishing in this class of car.

Tackle a tight bend and the MRC suspension instantly adjusts accordingly, stiffening each shock absorber as appropriate to the specific situation. Body roll is reduced and handling responsiveness is improved.

MRC excels on heaving, pitching road surfaces. Its constant adjustments help to keep DTS's body stable, resulting in a greater sense of control and a much more comfortable ride.

The world's fastest-reacting suspension technology, MRC takes the harshness out of rough, broken road surfaces.



Instead of the traditional mechanical throttle linkage, DTS connects your right foot to the Northstar V8 via drive-by-wire Electronic Throttle Control (ETC). This advanced electronic technology affords a greater degree of efficiency and control.

Pressure on the accelerator is relayed instantly to the engine, where it's translated into a precisely measured increase in the flow of the air-fuel mixture into the combustion chambers.

Software allows different levels of responsiveness in different situations. The result is more immediate performance on the highway and increased control in low-speed manoeuvres.

DTS's ETC is fully integrated with other electronic systems in the powertrain. Its links with the transmission allow for even smoother gear changes.

PRECISION

YOU'VE NEVER FELT MORE
INTIMATELY CONNECTED.

CONTROL

GO YOUR OWN WAY.

DTS's lengthy wheelbase, broad track and substantial tires make for a highly stable, predictable vehicle. Available StabiliTrak takes that a step further. In the event of a lateral skid, StabiliTrak detects that your DTS is no longer following your desired path. It steps in instantly, applying each brake individually as necessary to help restore vehicle control. It operates so unobtrusively it can often end a potentially dangerous skid before you even know it's begun.



STABILITRAK

ENGINEERING

CADILLAC TECHNOLOGY,
AT YOUR SERVICE.

INSPIRATION

DTS's delightful road manners derive from a long list of premium hardware systems. Some add to DTS's performance. Others, to a heightened sense of control and safety. And still others, to DTS's extraordinary comfort and sophistication. All have been carefully integrated to create a single, unified whole.

1. The standard 275 horsepower Northstar engine is tuned for high peak torque and excellent around-town acceleration. The available 291 horsepower version delivers increased power at higher engine speeds.
2. Front-wheel drive contributes to excellent traction and predictable handling. It also allows for a very spacious and accommodating passenger compartment.
3. The Northstar engine is mounted to a specially formed cradle, isolating the engine from the chassis so noise and vibrations to the body are minimized.
4. A robust body structure allows more exact tuning of the DTS suspension system, for superior ride and handling characteristics.
5. Standard Magnasteer is a responsive system that always provides just the right amount of power assist in every situation, from low-speed manoeuvring to highway cruising.
6. Large disc brakes at all four wheels, an anti-lock braking system (ABS) and Dynamic Rear Proportioning (DRP) all contribute to excellent brake performance.
7. DTS's fully independent suspension features front and rear stabilizer bars and has been specifically tuned for precise handling.
8. Available StabiliTrak helps correct lateral skids. It also includes Panic Brake Assist, which automatically applies maximum braking power when emergency braking is detected.
9. Should wheelspin occur at any speed, DTS's traction control will step in to restore control by reducing engine torque and, if necessary, applying the brakes.

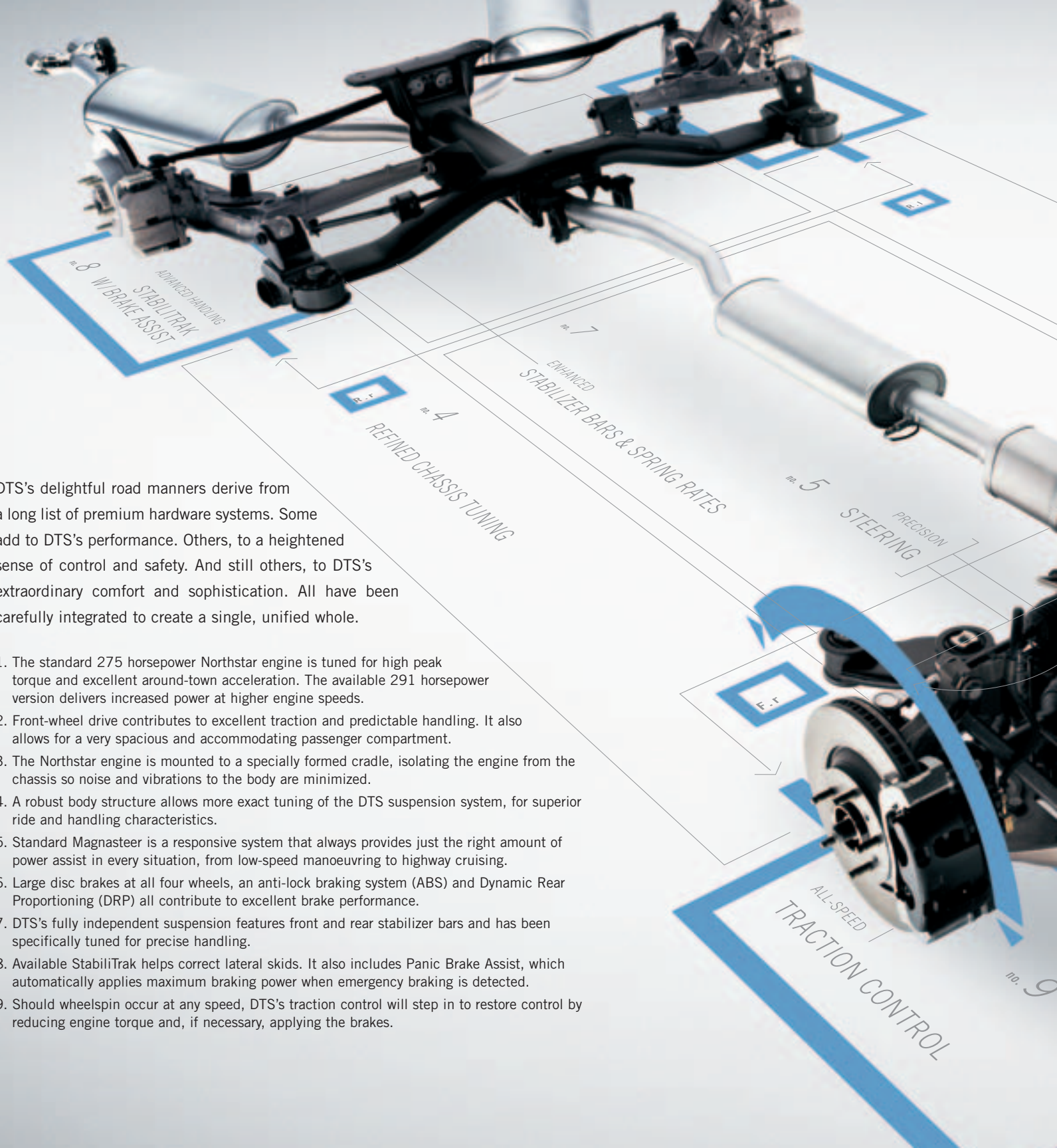

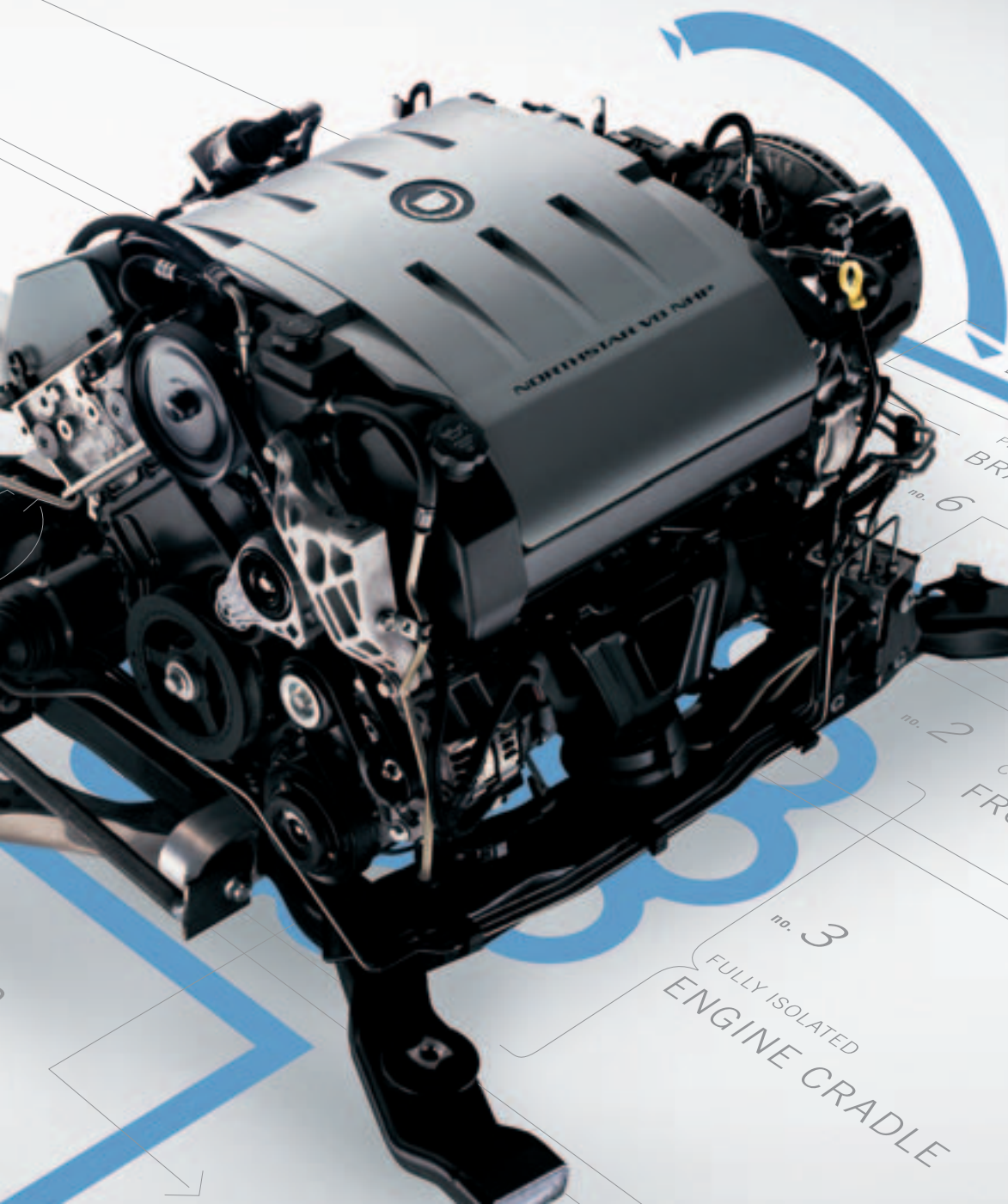

no. 3
FULLY ISOLATED
ENGINE CRADLE

no. 2
COMMANDING
FRONT-WHEEL DRIVE

no. 6
PERFORMANCE
BRAKING

RENEWED
4.6L NORTHSTAR
V8 NHP
● 288 LB-FT @ 4400 RPM
● 251 HP @ 5600 RPM

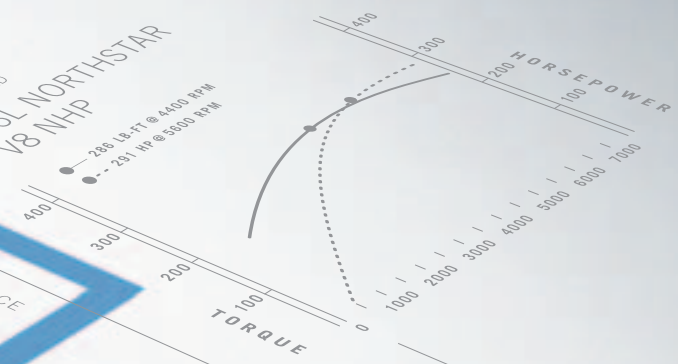

2006 DTS FEATURES & OPTIONS

SAFETY AND SECURITY

	DTS Luxury I
AIR BAGS	
Driver and front passenger-side, dual-stage, frontal with passenger-side automatic air bag suppression	S
Driver and front passenger-side, seat-mounted, side-impact	S
Front to rear, side head curtain	S
DOOR LOCKS	
Automatic power, programmable with lock-out protection	S
Rear door, child-security	S
HEADLIGHTS	
Daytime Running Lights, automatic light control with Twilight Sentinel	S
Windshield wiper activated	S
Xenon High-Intensity Discharge (HID)	S
KEYLESS ENTRY SYSTEM	
Remote includes remote start system, lock/unlock, personalization, notification activation and Panic feature; activates seat and climate control, windshield and rear defrost	S
ONSTAR SYSTEM	
Digital OnStar In-Vehicle Communications and Assistance Service, includes one-year Directions & Connections Plan	S
SAFETY RESTRAINTS	
LATCH (Lower Anchors and top Tethers for Children), rear seats	S
Tether anchors – child-seat, rear-seat 3-positions	S
THEFT-DETERRENT SYSTEM	
PASS-Key III+ with immobilizer	S
Tamper alarm for doors and trunk, audible/visible alarm	S
TRACTION CONTROL	
Electronic, full-function, all-speed with on/off switch	S
MECHANICAL	
BRAKES	
Power, 4-wheel discs	S
4-wheel, 4-channel anti-lock braking system (ABS) with Dynamic Rear Brake Proportioning	S
DRIVE	
Front-wheel drive	S
ENGINES	
4.6L Northstar V8 with 275 horsepower @ 5200 rpm and 292 lb.-ft. of torque @ 4400 rpm	S
Block heater	S
STEERING	
Speed-sensitive variable-assist, Magnasteer, rack-and-pinion	S
SUSPENSION	
4-wheel independent	S
Automatic rear-level control system	S
TRANSMISSION	
4-speed automatic with overdrive	S
INTERIOR	
AUDIO SYSTEMS	
AM/FM stereo with CD player, MP3 playback, auxiliary input jack, TheftLock and 8 speakers	S
AM/FM stereo with 6-disc in-dash CD changer, MP3 playback, Radio Data System (RDS), TheftLock and 8 speakers	0
AM/FM stereo with 6-disc in-dash CD changer, MP3 playback, weather band, Digital Signal Processing, 8 speakers, DVD Navigation for map coverage* in Canada and USA, GPS based, touch screen, voice and/or text guidance, DVD/video capabilities (vehicle in Park position only) and voice recognition	0
CARGO AREA	
Cargo convenience net	0
Trunk mat	0
CLIMATE CONTROL	
Automatic, tri-zone electronic climate control	S
Air filtration system	S
Rear air conditioning controls	S
CONSOLE	
Front centre floor console with shifter, armrest, two-level storage and dual cupholders and auxiliary power outlet	S
CRUISE CONTROL	
Electronic, steering wheel-mounted with resume, coast and decelerate/accelerate features	S
Adaptive Cruise Control, RADAR transceiver automatically adjusts speed to maintain pre-set following distance	0

INTERIOR (continued)

	DTS Luxury I
INSTRUMENTATION	
Analogue with Driver Information Centre	S
Tire pressure monitoring system	S
FLOOR MATS	
Front and rear, carpeted	S
LIGHTING	
Illuminated entry/exit, theatre dimming, instrument panel courtesy, glovebox, front map, rear reading and trunk	S
MEMORY/PERSONALIZATION PACKAGE	
Automatically recalls settings for 2 drivers based on their individual remote keyless access key fob; the recall function remembers the position of the driver's seat, exit seating position, exterior rear-view mirror preferences, passenger tilt-down parallel park feature, climate control settings, radio station and cellphone pre-sets and power tilt and telescopic steering wheel	0 ¹
MIRRORS	
Electrochromic, auto-dimming rear-view mirror with electronic compass and 3-button OnStar System	S
Illuminated driver and front-passenger visor vanity mirrors	S
SEATING	
Front bucket seats with power 10-way driver and front-passenger seat adjusters, power recliners and lumbar adjusters (5-passenger)	S
Divided bench front seat with power 10-way driver and front-passenger seat adjusters and power recliners (6-passenger)	0
Nuance leather seating surfaces	S
Tuscany full leather seats	0 ²
Teháma full leather seats**	0
Front heated and cooled seating areas, includes perforated leather seating areas	0 ³
Rear seatback, fixed back with armrest pass-through and dual cupholders	S
STEERING WHEEL	
Leather-wrapped with audio and cruise control switches	S
Tilt adjustable column	S
TRUNK	
Power remote release with Valet lock-out	S
UNIVERSAL HOME REMOTE	
3-channel programmable remote transmitter	0
WINDOWS	
Power with express-up and down feature on front windows with pinchguard and express-down feature on rear windows with window lock-out	S
WOOD ACCENTS	
Simulated medium ash wood accents on instrument panel and door inserts	S
EXTERIOR	
FRONT GRILLE	
Body-coloured, painted	0 ⁴
GLASS	
Solar-Ray, tinted	S
HOOD ORNAMENTATION	
Stand-up Cadillac wreath and crest	0
LIGHTS	
Fog lights	S
Front cornering lights	S
MIRRORS	
Foldaway, heated, power remote control, with integral turn signal in mirror glass	S
SUNROOF	
Power, tilt and sliding glass panel with express-open feature	0 ⁵
TIRES	
P235/55R17 S-rated, all-season	S
WHEELS	
17" x 7" 7-spoke machined aluminum (A)	S
17" x 7" 7-spoke chrome finish aluminum (B)	0
18" x 7.5" 9-spoke chrome finish aluminum (E)	0 ⁶
WIPER/WASHER SYSTEM	
Structureless, airfoil wipers, 2-speed with variable delay (intermittent)	S

S – Standard. 0 – Optional individually or in combination with other optional equipment.

PREFERRED EQUIPMENT GROUPS

	DTS Luxury II 1SC	DTS Luxury III 1SD	DTS Performance 1SE
MEMORY/PERSONALIZATION PACKAGE			
Automatically recalls settings for 2 drivers based on their individual remote access key fob: the recall function remembers the position of the driver's seat, exit seating position, exterior rear-view mirror preferences, passenger tilt-down parallel park feature, climate control settings, radio station and cellphone pre-sets and power tilt and telescopic steering wheel	•	•	•
MIRRORS			
Exterior, driver-side electrochromic auto-dimming feature	•	•	•
SEATING			
Front heated and cooled seating areas, includes perforated leather seating areas	•	•	•
Rear seat, heated outboard seating areas	•	•	•
STEERING WHEEL			
Leather, heated	•		
SUSPENSION			
StabiliTrak stability enhancement system 4-channel, includes Panic Brake Assist	•	•	•
ULTRASONIC PARKING ASSIST			
Front and rear obstacle detection system with audible/visible warning	•	•	•
UNIVERSAL HOME REMOTE			
3-channel programmable remote transmitter	•	•	•
WIPER/WASHER SYSTEM			
Heated windshield washer fluid	•	•	•
AUDIO SYSTEM			
AM/FM stereo with 6-disc in-dash CD changer, MP3 playback, Radio Data System (RDS) and TheftLock		•	•
Bose Premium Sound System Package – includes 8 Bose amplified speakers		•	•
CARGO AREA			
Cargo convenience net		•	•
Trunk mat		•	•
LIGHTS			
IntelliBeam headlights with automatic low/high beam control		•	•
MIRRORS			
Power folding		•	•
Rear-seat overhead illuminated vanity mirrors		•	•
SEATING			
Driver and front-passenger power lumbar massaging		•	•
Rear seat, height adjustable head restraints		•	•
Rear seat, power 4-way lumbar adjusters		•	•
STEERING WHEEL			
Leather, heated with natural Burl Walnut wood accents		•	•
Power tilt and telescopic adjustable column		•	•
SUNSHADE			
Rear window, power		•	•
WHEELS			
17" x 7" 9-spoke chrome finish aluminum (C)		•	
WIPER/WASHER SYSTEM			
Rainsense with automatic variable delay		•	•
WOOD ACCENTS			
Natural Burl Walnut wood trim on instrument panel, door insert, steering wheel, shifter plate and shift knob with front bucket seats		•	•
ENGINE			
4.6L Northstar V8 High-output with 291 horsepower @ 5600 rpm and 286 lb.-ft. of torque @ 4400 rpm			•
SUSPENSION			
Magnetic Ride Control – computer controlled suspension system with adjustable shock absorbers			•
TIRES			
P245/50R18 H-rated, all-season			•
TRANSMISSION			
4-speed automatic with overdrive and Performance Algorithm Shifting			•
WHEELS			
18" x 7.5" 9-spoke machined finish aluminum (D)			•

DIMENSIONS

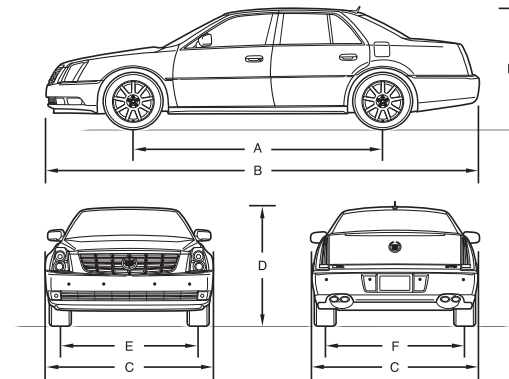

EXTERIOR DIMENSIONS

Wheelbase (A)	2936 mm (115.6 in.)
Length (B)	5273 mm (207.6 in.)
Width (C)	1900 mm (74.8 in.)
Height (D)	1463 mm (57.6 in.)
Front track (E)	1591 mm (62.6 in.)
Rear track (F)	1580 mm (62.2 in.)

INTERIOR DIMENSIONS

Headroom	
Front/rear	973/975 mm (38.3/38.4 in.)
Legroom	
Front/rear	1076/1067 mm (42.4/42.0 in.)
Shoulder room	
Front/rear	1524/1509 mm (60.0/59.2 in.)
Hip room	
Front/rear	1455/1415 mm (57.3/55.7 in.)
Seating capacity	5/6

CAPACITIES

Fuel	68 L (18.0 imp. gal.)
Cargo volume	532 L (18.8 cu. ft.)
Towing ¹	454 kg (1000 lb.)

CURB WEIGHT, ESTIMATED

DTS	1836 kg (4047 lb.)
-----	--------------------

¹Includes weight of trailer, cargo, passengers and equipment. All towing recommendations are subject to change. Trailer tongue load should be 10% of the maximum trailer weight but should never exceed the load rating for that vehicle, engine or hitch combination. See your dealer or refer to the DTS Owner's Manual for details.

- Requires available heated and cooled seats.
- Not available with 6-passenger divided bench front seating.
- Requires Memory/Personalization Package.
- Not available with Adaptive Cruise Control.
- Deletes rear-seat overhead vanity mirrors and requires universal home remote.
- Available with PEG 1SE only.
- Power tilt and telescopic steering wheel not included in PEG 1SC.

*At time of print, detailed map coverage is available for most major urban areas of the United States and for certain metropolitan areas of Canada (Vancouver, Calgary, Edmonton, Winnipeg, Windsor, London, Toronto, Ottawa, Montreal, Quebec City and Halifax). Coverage is significantly limited outside these areas. Choose the factory navigation option and you will receive an updated navigation DVD each of the first two years following your purchase.

**Interim availability, please see your Sales Consultant for more information regarding Tehama leather.

WHEELS AND TIRES



A – 17" x 7"
7-spoke machined aluminum wheels with P235/55R17 S-rated tires.
Standard with DTS Luxury I/II Packages



B – 17" x 7"
7-spoke chrome finish aluminum wheels with P235/55R17 S-rated tires.
Available with DTS Luxury I/II Packages



C – 17" x 7"
9-spoke chrome finish aluminum wheels with P235/55R17 S-rated tires.
Included with DTS Luxury III Package



D – 18" x 7.5"
9-spoke machined aluminum wheels with P245/50R18 H-rated tires.
Included with DTS Performance Package



E – 18" x 7.5"
9-spoke chrome finish aluminum wheels with P245/50R18 H-rated tires.
Available with DTS Performance Package

DEALER AVAILABLE OPTIONS

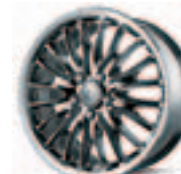

18" chrome wheels – these 20-spoke forged aluminum wheels feature a lustrous chrome finish.
Available with DTS Performance Package



18" chrome wheels – these 10-spoke forged aluminum wheels feature a highly-polished chrome finish.
Available with DTS Performance Package



CADILLAC OWNER PRIVILEGES

In addition to an exceptional driving experience, Cadillac ownership brings with it a world-class array of privileges. Cadillac No-Charge Scheduled Maintenance pays for all regularly scheduled maintenance.* The Limited Warranty covers all parts and labour costs that may be incurred to correct defects in material or workmanship.* Cadillac Roadside Service provides assistance throughout Canada and the United States should you require towing, fuel delivery, a jump start or help with a flat tire or lock-out situation.* Trip Planning can assist you on road trips with computer-generated maps indicating either the most direct route or the most scenic route to any destination you choose in North America.* Alternative Transportation provides you with shuttle

transportation for daily service and an alternate car (or reimbursement for rental or other transportation expenses) for overnight service, whenever your Cadillac requires scheduled maintenance or repairs covered under the Limited Warranty.* Trip Interruption Protection ensures that you will be reimbursed by General Motors of Canada for reasonable hotel, meal and alternative transportation expenses incurred should your trip be interrupted by a repair covered under the Limited Warranty. See your Cadillac dealer for complete details.

*Program in effect for the first 4 years or 80,000 km (whichever comes first) of ownership. Conditions and limitations apply.

ONSTAR

Safety, security, convenience and thoughtfulness are engineered into every 2006 Cadillac. OnStar takes each of those virtues a step further. OnStar uses advanced communications technology to enhance your peace of mind whenever you're in your Cadillac.* All it takes is a single push on the blue OnStar button usually located on the interior rear-view mirror, in the overhead console, or near the radio display to connect you with one of our specially trained OnStar Advisors. They are standing by, ready to provide support 24 hours a day, 365 days a year.

Now you can enjoy the peace of mind that comes with knowing you're doing all you can to help keep you, your family, and your vehicle safe. Just ask the almost 150,000 people who have become OnStar subscribers in Canada. How hard does OnStar work for you? The facts speak for themselves: every month in Canada OnStar Advisors handle an average of 9100 routing calls, 2500 emergency calls, 2600 door unlocks, and 625 Roadside Assistance dispatches.

The OnStar System and one year of the Directions & Connections Plan is included on DTS, offering you access to driving directions, information and convenience services and Ride Assist. See your dealer for more information on plans and services.

What can OnStar Advisors do for you? They not only provide information and a wide range of other services – but also, in an emergency, they will attempt to locate your vehicle, find out what assistance you need, and notify nearby emergency service providers. And if air bags are deployed in your vehicle, an Advisor will contact you to determine if you are in need of assistance. Your Advisor can also perform a remote diagnostic check of your engine and electrical components in your vehicle.

Another convenient feature is OnStar Hands-Free Calling, a hands-free, voice-activated wireless technology integrated into your vehicle. It's there just in case your hand-held phone is lost, forgotten or has a low battery. Even better, there are no additional monthly fees, or additional long distance and roaming charges. And as a new customer, you will receive 30 complimentary minutes good for two months after activation.

*OnStar services require vehicle electrical system (including battery), wireless service, and GPS satellite signals to be available and operating for features to function properly. Not all OnStar features are available on all vehicles. OnStar Hands-Free Calling requires a Hands-Free enabled vehicle, existing OnStar service contract, and prepaid calling minutes, and is not available in Alaska and some other markets. Calls may be made to the U.S. and Canada only. OnStar voice recognition system may not work with some voices. OnStar acts as a link to existing emergency service providers. Subscription Service Agreement required. Due to the transition of the wireless industry from analogue to digital technology, as of January 1, 2008, OnStar plans to offer service only through equipment that operates on the digital network, which may require the purchase of a system upgrade for eligible vehicles. Call 1.888.4.ONSTAR (1.888.466.7827), TTY 1.877.248.2080 or visit onstar.ca for OnStar's Terms & Conditions, Privacy Policy, and system limitations and details.



visit onstar.ca



EXTERIOR COLOURS

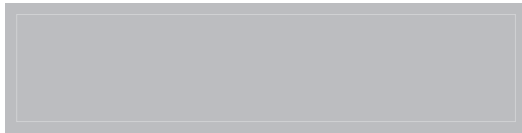

Blue Chip**

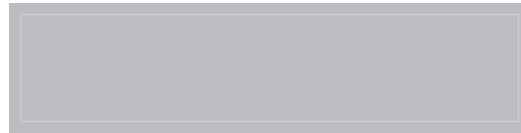

Black Raven

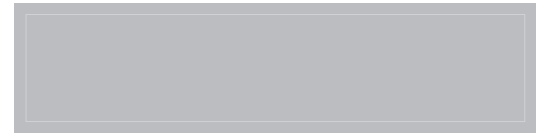

Silver Smoke**

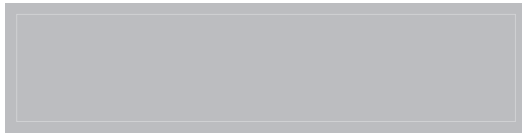

Stealth Gray

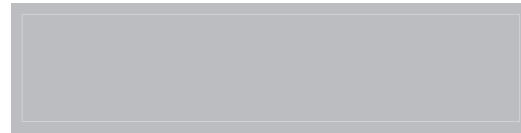

Radiant Bronze**

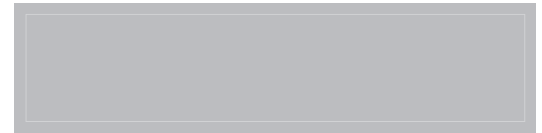

Sand Storm**



Light Platinum



White Diamond*

FPO -
CTS COLOUR CHIP FRONT
PRINTS SEPERATELY

INTERIOR COLOURS

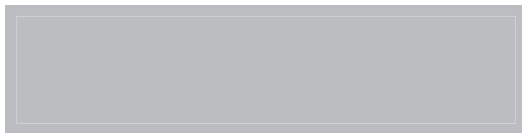

Light Gray

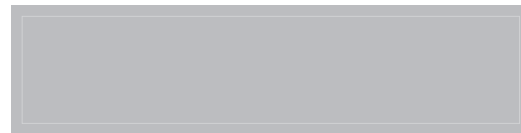

Ebony



Two-Tone: Light Gray/Ebony

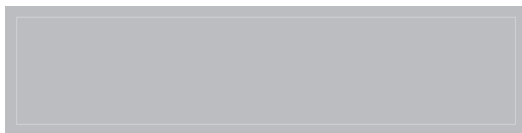

Cashmere

*Available at extra cost.

**Not available on CTS-V.

†Interior colour Light Gray/Ebony two-tone not available with exterior colour Sand Storm. KURT????

‡Interior colour Ebony not available with exterior colour Blue Chip. KURT????

ACQUISITION OPTIONS

In addition to the many exclusive privileges of Cadillac ownership, Cadillac and General Motors of Canada have created a range of supplementary support programs to enhance your ownership experience. Some of these programs assist you in purchasing or leasing the Cadillac of your choice. Others help protect you and your new Cadillac over the long term.

Purchasing & Leasing:

- **GMAC Financing** – On-the-spot financing at your GM dealership*
- **GMAC SMARTLEASE** – A smart alternative to traditional financing*
- **The GM Card** – Eligible cardholders may be able to redeem up to \$3500 in GM Card®

Earnings toward the total purchase price of vehicles.** For more information on The

Additional Ownership Programs:

- **GM Protection Plan (GMPP)** – the only extended warranty program that covers your sale or lease, or subsequently**
- **GM Mobility Program** – you may be eligible for tax credits (taxes included) for adaptive equipment

Information Resources:

You can obtain more information about Cad

Cadillac dealer, or at these information centres:

- The GM Web site at gmcanada.com
- The Cadillac Communications Marketing Centre at 1-888-446-2000 or (1-800-263-3830 for TDD users) – For information about any GM product or service, including the GM Mobility Program
- For information about GMAC, visit the GM Web site or call 1-800-616-4622.

*Subject to eligibility.

**Conditions and limitations apply.

A word about this brochure

We have tried to make this brochure comprehensive and factual. We reserve the right, however, to make changes at any time, without notice, in prices, colours, materials, equipment, specifications, models and availability. Specifications, dimensions, measurements, ratings and other numbers in this brochure and other printed materials provided at the dealership or affixed to vehicles are approximates based upon design and engineering drawings and prototypes and laboratory tests. Your vehicle may differ due to variations in manufacture and equipment. Since some information may have been adapted since the time of the printing, please check with your Cadillac dealer for complete details. General Motors of Canada Limited reserves the right to lengthen or shorten the model year for any product, for any reason, or to start and end model years at different times.

Privacy statement

At General Motors of Canada Limited ("GM Canada") we respect your privacy and value our relationship with you. Your personal information will be protected, will never be sold, and will never be used only by GM Canada, our affiliates, dealers/retailers, and service suppliers (only to provide services). If you wish to be removed from GM Canada marketing communications; would like to limit

FPO -
CTS COLOUR CHIP BACK
PRINTS SEPERATELY

badge, Cadillac Owner Privileges, Cadillac Roadside Service, Corvette Z06, CTS, CTS-V, DTS, Escalade, ESV, EXT, SRX, STS, XLR, and their respective logos, emblems, slogans and vehicle model names and body designs; and other marks such as breakthrough SMARTLEASE, Solar-Ray, StabiliTrak, and Twilight Sentinel are trademarks of General Motors Corporation and/or General Motors of Canada Limited, its subsidiaries, affiliates or licensors.

GMAC is a registered trademark of the General Motors Acceptance Corporation.

OnStar, the OnStar logo and the OnStar button are registered trademarks of the OnStar Corporation.

PASS-Key III+ and TheftLock are registered trademarks of Delphi Automotive Systems.

Bose and AutoPilot are registered trademarks of the Bose Corporation.

Radio Data Systems (RDS) is a registered trademark of the U.S. National Association of Broadcasters.

Copyright

© Copyright 2005 General Motors of Canada Limited. All Rights Reserved. All text, images, graphics, and other materials in this Cadillac CTS brochure are subject to the copyright and other intellectual property rights of General Motors Corporation and/or General Motors of Canada Limited. These materials may not be reproduced, distributed or modified without the express written permission of General Motors Corporation and/or General Motors of Canada Limited.

Printed in Canada, June 2005.

A STORY ONLY GENERAL MOTORS CAN TELL.

General Motors' commitment to setting the highest standards in quality, safety, innovation, and fuel efficiency are matched by an equally strong commitment to the community.

DID YOU KNOW?

QUALITY: GM plants swept the J.D. Power Initial Quality Study^{SM*} rankings for North and South America: Gold and Silver Plant Quality Awards for the Canadian Oshawa #2 and #1 car plants, in addition to the Bronze Plant Quality Award for the Hamtramck, Michigan plant.

SAFETY: General Motors is the only automotive manufacturer committed to offering a full range of cars, trucks, and SUVs that provide safety protection before, during and after a collision.

GM vehicles are equipped with a range of features and technologies that help drivers avoid collisions, reduce the risk of injury should a collision prove unavoidable, and help you get the assistance you need after a collision.

INNOVATION: GM is at the forefront of automotive technology with breakthrough features such as OnStar and XM Satellite Radio.

FUEL EFFICIENCY: GM offers more cars than any other automaker in Canada that get better than 7.0 L/100 km in highway driving. GM has also won more EnerGuide fuel-efficiency awards than any other car company.

GM IS COMMITTED TO CANADA

INVESTMENT: GM invests more in Canada than any other car company. The \$2.5 billion Beacon Project represents the largest automotive investment in Canadian history.

EMPLOYMENT: GM directly employs over 20,000 people in Canada – more than any other car company.

DESIGN: GM is the only car company that designs, engineers and builds cars in Canada.

GM IS BEHIND YOU AND YOUR VEHICLE

GM is equally comprehensive in the way it backs its Cadillac vehicles. All Cadillac models include:

- 4-year/80,000 km^{**} complete vehicle repair coverage
- 6-year/unlimited km corrosion perforation coverage
- 8-year/130,000 km^{**} coverage on catalytic converters and powertrain control modules (PCMs)
- 4-year/80,000 km^{**} 24-hour Roadside Service
- 4-year/80,000 km^{**} no-charge scheduled maintenance
- 4-year/80,000 km^{**} trip planning.

*General Motors Corporation - Oshawa #2 (Ontario - Car) was the highest ranked plant, Oshawa #1 (Ontario) was the second ranked plant and Hamtramck, MI was the third ranked plant in North/South America among plants producing vehicles for the U.S. market in J.D. Power and Associates 2005 U.S. Initial Quality StudySM. Study based on a total of 62,251 U.S. consumer responses indicating owner reported problems during the first 90 days of ownership. www.jdpower.com

**Whichever comes first.



CHEVROLET PONTIAC BUICK GMC CADILLAC SATURN SAAB HUMMER

gmcanada.com

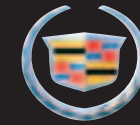

At Cadillac, luxury is a concept of many dimensions. It is suppleness, and it is strength. It can be agile, but when called for, it can also be unwavering. It whispers, yet on occasion, it roars. It is quality, and refinement, and confidence. It responds. It comforts. It protects. It entertains. And it delights. For 2006, this enticing, elusive concept has inspired a handful of vehicles that rank among the finest in the world. Perhaps one is right for you.