

# SERIOUS TRUCKS



## TOWING & RECOVERY

|       |             |                |       |
|-------|-------------|----------------|-------|
| 4700  | 4800        | 4900           | 6900  |
| SF SB | SF SB<br>TS | SF SB<br>EX TS | XD TS |



Serious trucks.™



# DOMINATE THE JOB. WHATEVER THAT JOB IS.



From big to very big. You're the one who gets the call. So you have to be ready and you need trucks you can count on. From the 4700 to the 6900, we have those trucks. And they're built to flat out work, every single day. No excuses. No complaints. That's because Western Star® is the work truck that was built to be a work truck.

Even better, we build your truck exactly how you want it. That's something we've been doing since we finished our first one over 40 years ago – each one completely custom and ready to take on any job with the durability to come back for more. No wonder Stars are the trucks real pros turn to.







### A nice place to call work.

The cab of the Western Star is luxurious. Yes, we said it. And just wait till you see it. Quiet, spacious, comfortable and completely new. There's even a navigation package, so you'll always know where you're going. Customers will be impressed and everyone will be safer with a steel cab that offers incredible visibility. You might feel spoiled. Almost.



### THE DURABILITY OF A SERIOUS TRUCK.

On our trucks, every component is a critical component. That's important, especially for what you do. So we use only parts that meet our standards for strength and longevity, just like we have since the beginning. After all, if it's not broke, don't fix it.

### POINT-TO-POINT WIRING.

In your job, dependability is mandatory. After all, you're the one they call when they break down. With point-to-point wiring, you'll eliminate a possible point of failure, and more importantly, a chance of losing income.



# READY, WILLING AND MORE THAN ABLE.



Western Star® trucks are built to perform, with the high-quality components that stand up to the challenge of hard work. Sure, you can buy a less expensive truck. But that only costs you in the long run.

### All hail the steel cab.

No aluminum or rivets here. Our galvanized steel cabs are built to keep you safe. Extra gussets and reinforcements, bonded instead of riveted, precision welded for strength, then dipped and protected with a 17-stage e-coat process for long-lasting corrosion resistance and a superior paint finish. Strength and longevity are the goals. We'd say they've been exceeded.



### The answer is yes.

The question, well, you'll have to supply that. With thousands of options and a work force dedicated to hand building the truck you need, Western Star delivers true factory customization, all backed by a single factory warranty. If there's something you need, just ask.



### You need power. We have it.

When it comes to choosing an engine, compromise should never enter the conversation. We offer a variety of engines with horsepower and torque ratings to match your job. Getting what you want has never been easier.

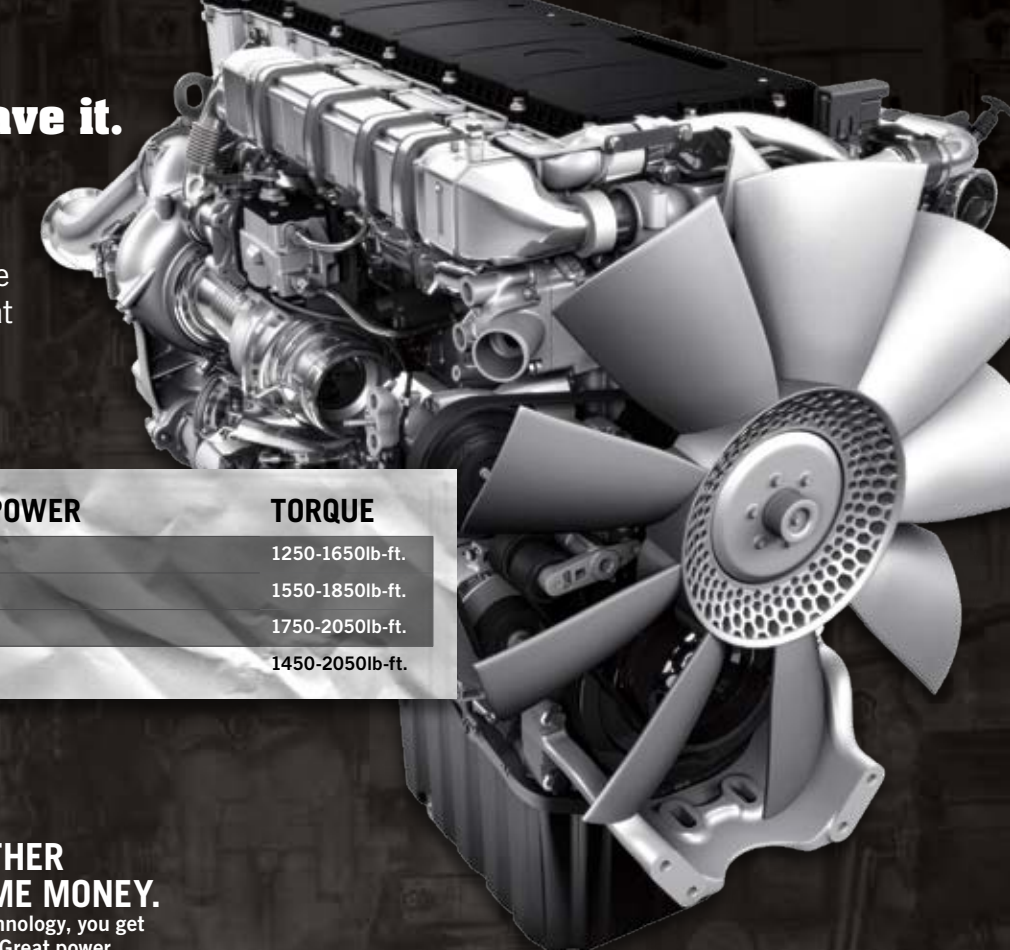

| ENGINE         | HORSEPOWER | TORQUE           |
|----------------|------------|------------------|
| DETROIT™ DD13* | 350-470    | 1250-1650lb.-ft. |
| DETROIT™ DD15* | 455-560    | 1550-1850lb.-ft. |
| DETROIT™ DD16* | 475-600    | 1750-2050lb.-ft. |
| CUMMINS ISX15  | 400-600    | 1450-2050lb.-ft. |



### EFFICIENCY. JUST ANOTHER WAY TO MAKE YOU SOME MONEY.

With Detroit™ BlueTec® emissions technology, you get everything you need to run profitably. Great power, dependability and up to 5% better fuel economy.\*



DETROIT DD15

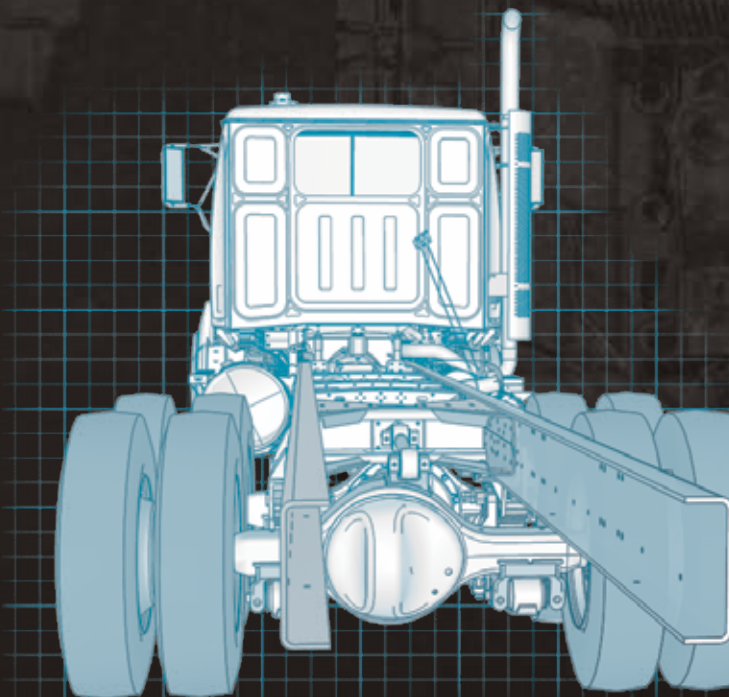

### BODY BUILDER FRIENDLY.

We make trucks with the body builder-specific options that are designed to reduce installation time and ensure years of trouble-free operation. Plus, since we build each truck to your specifications, anything is possible. Pre-punched frame rails, front frame extensions, point-to-point power distribution, ample room between the seats to install controls—the list goes on. Just ask your dealer.

WESTERNSTAR.COM





## 4700

**SF SET FORWARD AXLE**

|          |                |
|----------|----------------|
| <b>A</b> | BBC: 110"      |
| <b>B</b> | WB: Up to 300" |
| <b>C</b> | BA: 29"        |

**SB SET BACK AXLE**

|          |                |
|----------|----------------|
| <b>A</b> | BBC: 110"      |
| <b>B</b> | WB: Up to 300" |
| <b>C</b> | BA: 47"        |

## 4800

**SF SET FORWARD AXLE**

|          |                |
|----------|----------------|
| <b>A</b> | BBC: 109"      |
| <b>B</b> | WB: Up to 448" |
| <b>C</b> | BA: 33"        |

**SB SET BACK AXLE**

|          |                |
|----------|----------------|
| <b>A</b> | BBC: 109"      |
| <b>B</b> | WB: Up to 448" |
| <b>C</b> | BA: 50"        |

**TS TWIN STEER, SF SB**

|          |                       |
|----------|-----------------------|
| <b>A</b> | BBC: 109"             |
| <b>B</b> | WB: Up to 448"        |
| <b>C</b> | BA: 33"(SF) / 50"(SB) |

## 4900

**SF SET FORWARD AXLE**

|          |                |
|----------|----------------|
| <b>A</b> | BBC: 123"      |
| <b>B</b> | WB: Up to 448" |
| <b>C</b> | BA: 33"        |

**SB SET BACK AXLE**

|          |                |
|----------|----------------|
| <b>A</b> | BBC: 123"      |
| <b>B</b> | WB: Up to 448" |
| <b>C</b> | BA: 50"        |

**EX EXTENDED HOOD**

|          |                |
|----------|----------------|
| <b>A</b> | BBC: 132"      |
| <b>B</b> | WB: Up to 448" |
| <b>C</b> | BA: 33"        |

**TS TWIN STEER**

|          |                |
|----------|----------------|
| <b>A</b> | BBC: 123"      |
| <b>B</b> | WB: Up to 448" |
| <b>C</b> | BA: 50"        |

## 6900

**XD EXTREME DUTY**

|          |                |
|----------|----------------|
| <b>A</b> | BBC: 141"      |
| <b>B</b> | WB: Up to 486" |
| <b>C</b> | BA: 59"        |

**TS TWIN STEER**

|          |                |
|----------|----------------|
| <b>A</b> | BBC: 141"      |
| <b>B</b> | WB: Up to 486" |
| <b>C</b> | BA: 59"        |



For the Western Star® dealer nearest you, call 1-866-850-STAR | [WESTERNSTAR.COM](http://WESTERNSTAR.COM)

WS/MC-B-398. Specifications subject to change without notice. Western Star Truck Sales, Inc. is registered to ISO 9001:2000 and ISO 14001:2004. Copyright © 2012 Daimler Trucks North America LLC. All rights reserved. Western Star Truck Sales, Inc. is a subsidiary of Daimler Trucks North America LLC, a Daimler Company.