

SERIOUS TRUCKS



MUNICIPAL

4700	4800	4900
SF SB	SF SB TS	SF SB XD TS



Serious trucks.™

THE END OF COMPROMISE HAS BEEN ACHIEVED.



You don't want the almost right truck. You want the right truck. Which is just another way to say a Western Star®. It's designed to flat out work, every single day. No excuses. No complaints. That's because this is the work truck that was built to be a work truck. And we have a whole family of them that can be customized to do whatever you need.

In fact, a Star is so well-built, it's going to keep running long after the others stop. And the low cost of operation you get over the life of your Western Star truck makes it a true long-term investment. That's how we've been doing it since we built our first one over 50 years ago. With this kind of value, no wonder Stars are the trucks real pros turn to.



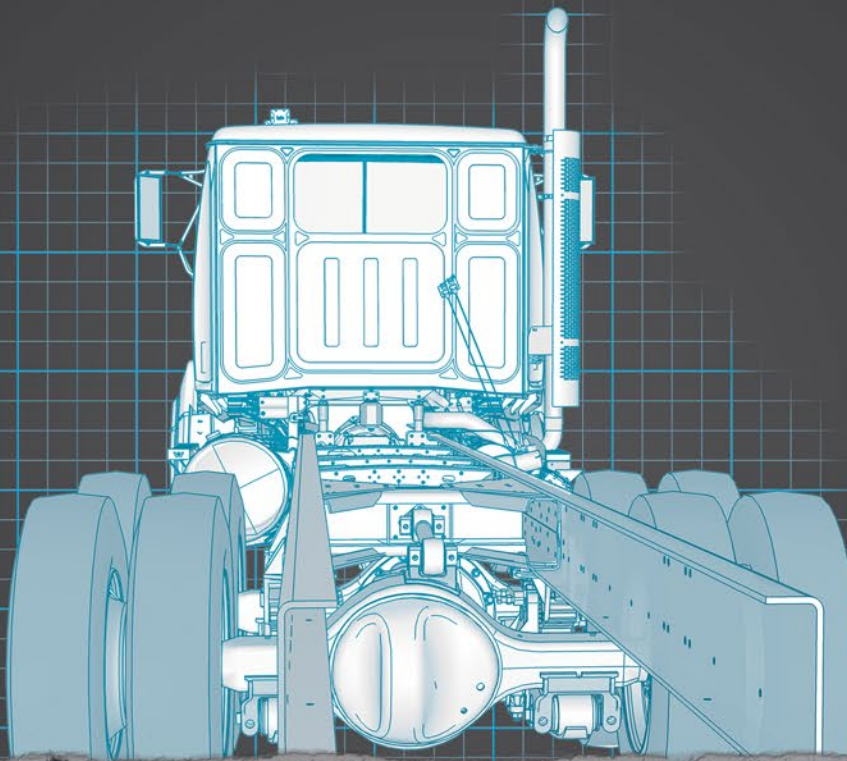

Body builder friendly.
 We make trucks with the body builder-specific options that are designed to reduce installation time and ensure years of trouble-free operation. Plus, since we build each truck to your specifications, anything is possible. Pre-punched frame rails, front frame extensions, point-to-point power distribution, ample room between the seats to install controls – the list goes on. Just ask your dealer.



A NICE PLACE TO CALL WORK.
 The cab of the Western Star is built to make the job easier and more comfortable. Large, waterproof switches that let you work with gloves on. A quiet, insulated cab that's easy to get in and out of. Greater visibility. More leg room. More storage. More space between seats. Your drivers might feel spoiled. Almost.

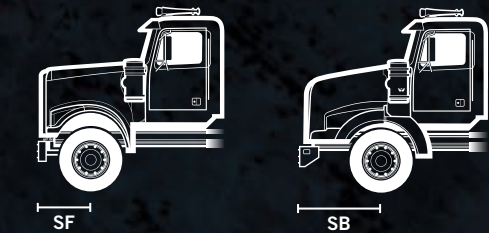

SET FORWARD OR SET BACK. YOUR CHOICE.
 Whichever model you need, with Western Star, you decide on front axle placement. Specify set back (SB) front axles for maximum maneuverability or choose set forward (SF) to maximize bridge law formulas.



LET IT SNOW.
 When you're operating a plow, you don't want snow getting into your engine. In-cab controlled snow doors with optional underhood air cleaners keep snow out in the harshest conditions, so you can stay working.

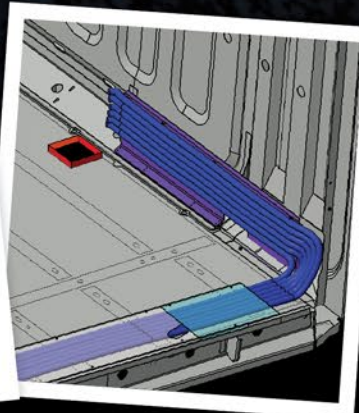

WIRING MADE EASY.
 Our 4700 features a number of body builder-friendly features that make connections easier. Like in-cab wiring and interface connectors. A bolt-in pass-through plate in the cab floor to eliminate unnecessary drilling. And a dedicated floor channel with an easy-to-remove top that provides plenty of room to run your own wiring. Like we said, easy.

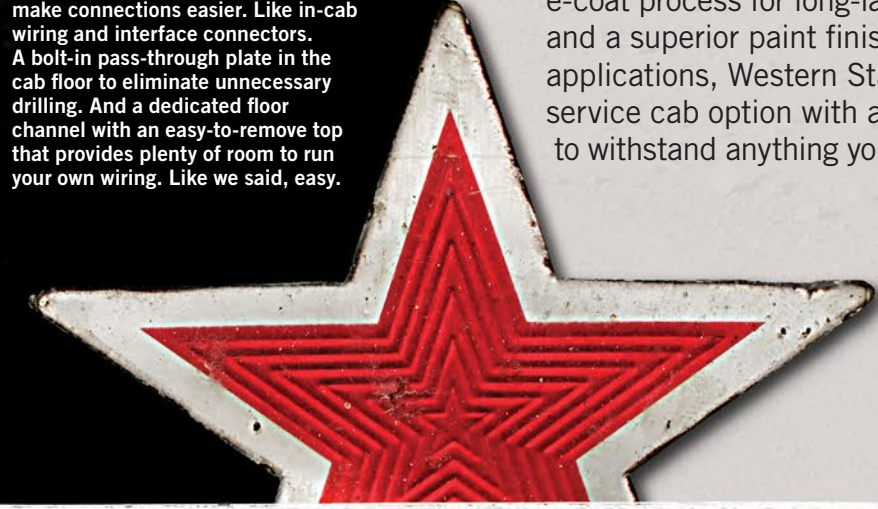

READY, WILLING AND MORE THAN ABLE.

Western Star® trucks are built to perform, with the high-quality components that stand up to the challenge of hard work. Sure, you can buy a less expensive truck. But that only costs you in the long run.



Safe and sound.
 Our cabs are built to keep you safe. Bonded instead of riveted, precision welded for strength, then dipped and protected with a multi-stage e-coat process for long-lasting corrosion resistance and a superior paint finish. And for extreme-duty applications, Western Star also offers a severe service cab option with additional reinforcements to withstand anything you can throw at it.

The answer is yes.
 The question, well, you'll have to supply that. With thousands of options and a work force dedicated to hand building the truck you need, Western Star delivers true factory customization all backed by a single factory warranty. If there's something you need, just ask.



Close enough just isn't good enough.
 When it comes to choosing an engine, close enough should never enter the conversation. So for municipal applications, we offer a variety of engines with horsepower and torque ratings to match your job. Getting what you want has never been easier.

ENGINE	HORSEPOWER	TORQUE
DETROIT™ DD13*	350-505	1250-1850lb.-ft.
DETROIT™ DD15*	400-505	1550-1750lb.-ft.
DETROIT™ DD16*	500-600	1850-2050lb.-ft.
CUMMINS L9	260-380	720-1250lb.-ft.
CUMMINS X15	400-600	1450-2050lb.-ft.

DEMAND POWER AND EFFICIENCY.
 Detroit™ engines are engineered to deliver the excellent power and fuel economy you depend on while still meeting today's efficiency requirements. That's why each engine we build is 2016 OBD (OBD16) Certified and compliant with 2017 Greenhouse Gas (GHG17) regulations. So you can count on a powerplant that will run clean and strong for many miles to come.



ALL CONDITIONS ARE WORKING CONDITIONS.
 A Western Star truck is built to perform no matter how hot or how cold. So you'll find options like heated windshields, arctic wiper blades and access hatches in the hood to keep you running even when the conditions are less than ideal.



EASY MAINTENANCE. GREATER UPTIME.
 We engineer our trucks to be simple to work on. From changing air filters or replacing fuses to accessing major components, a Star is made to keep you on the road and running.



DETROIT DD13



4700

SF SET FORWARD AXLE

A	BBC: 110"
B	WB: Up to 300"
C	BA: 29"

SB SET BACK AXLE

A	BBC: 110"
B	WB: Up to 300"
C	BA: 47"

4800

SF SET FORWARD AXLE

A	BBC: 109"
B	WB: Up to 448"
C	BA: 33"

SB SET BACK AXLE

A	BBC: 109"
B	WB: Up to 448"
C	BA: 50"

TS TWIN STEER, SF SB

A	BBC: 109"
B	WB: Up to 448"
C	BA: 33"(SF) / 50"(SB)

4900

SF SET FORWARD AXLE

A	BBC: 123"
B	WB: Up to 448"
C	BA: 33"

SB SET BACK AXLE

A	BBC: 123"
B	WB: Up to 448"
C	BA: 50"

XD EXTREME DUTY

A	BBC: 123"
B	WB: Up to 448"
C	BA: 50"

TS TWIN STEER

A	BBC: 123"
B	WB: Up to 448"
C	BA: 50"

Follow us on:    



For the Western Star Dealer nearest you, call 1-866-850-STAR | WESTERNSTAR.COM

WS/MC-B-399. Specifications are subject to change without notice. Western Star Truck Sales, Inc. is registered to ISO 9001:2008 and ISO 14001:2004. Copyright © 2018 Daimler Trucks North America LLC. All rights reserved. Western Star Truck Sales, Inc. is a subsidiary of Daimler Trucks North America LLC, a Daimler company.

DAIMLER | Western Star - A Daimler Group Brand