

CONFIDENTIAL

FALCON, FAIRLANE, FORD, THUNDERBIRD, AND NOW....

THE NEW FORD MUSTANG

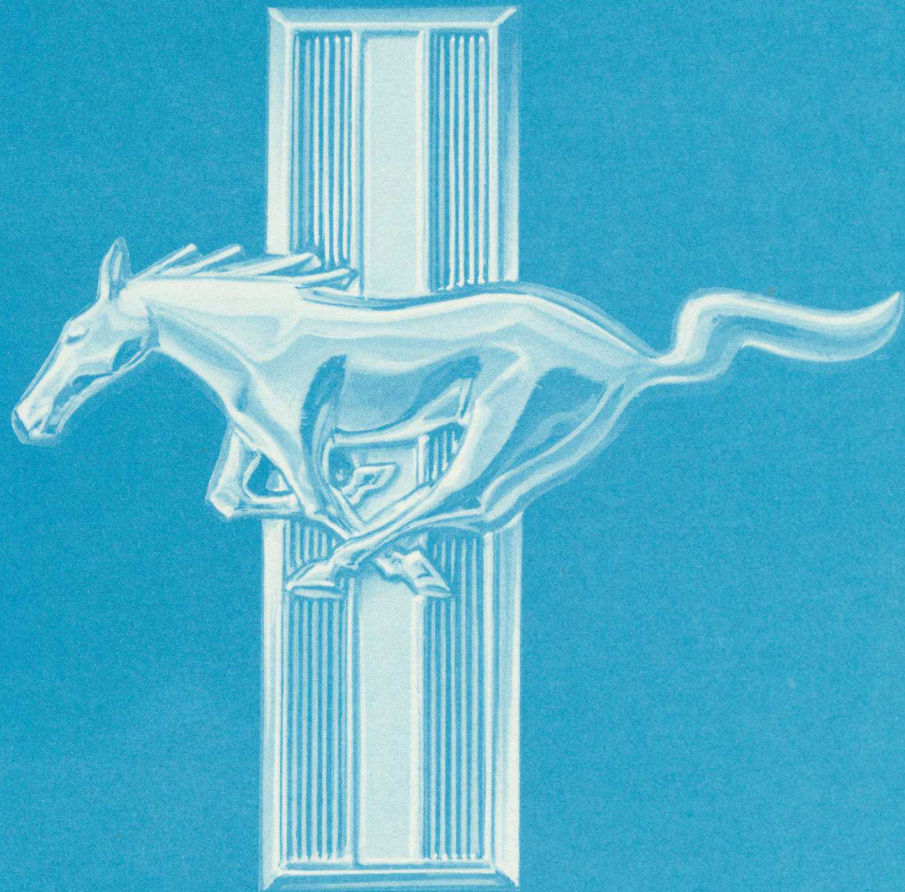

**TECHNICAL INFORMATION FOR PRESS USE ONLY
FOR RELEASE PM'S APRIL 13, 1964**

REGISTRATION NO. _____



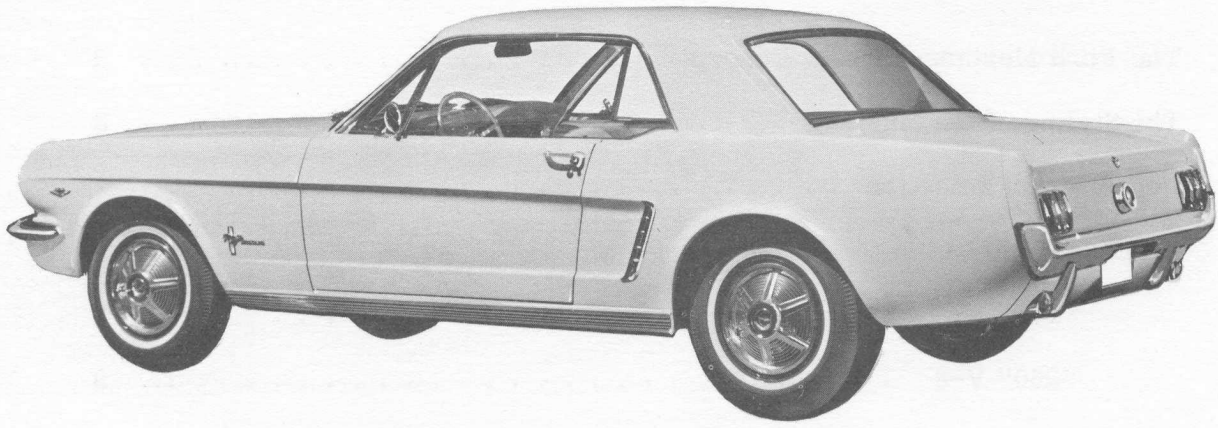

TABLE OF CONTENTS

The Ford Mustang: A New Concept	3
The Styling of the Mustang	3
Power Team Selection	7
Mustang Engines	
"170" Six	8
"260" V-8	9
"289" V-8	10
"289" High-Performance V-8	11
Mustang Transmissions	
3-Speed Manual	12
4-Speed Manual	12
Cruise-O-Matic	13
Mustang Rear Axle and Drive Line	15
Mustang Chassis	16
Mustang Bodies	18
Mustang Specifications	21
Mustang Standard Equipment Features	22
Mustang Options and Accessories	24
Public Relations Field Office Locations	26

The descriptions and specifications contained in this book were in effect at the time the publication was approved for printing. The Ford Division of Ford Motor Company, whose policy is one of continuous improvement, reserves the right to discontinue models at any time, or change specifications or design without notice and without incurring obligation. All options and accessories illustrated or referred to as optional or available in this book are at extra cost.

THE FORD MUSTANG: A NEW CONCEPT

The Ford Division of Ford Motor Company presents a new American automotive concept with the MUSTANG. The compact design combines with eight engine and transmission choices to tailor Mustangs ranging from fun-to-drive economy cars to high-performance road cars — all with luxury and sports options as desired.

Both Mustang models — hardtop and convertible — feature a spacious two-plus-two seating arrangement with front bucket seats as standard equipment and a bench-type rear seat. Shift levers for all transmissions are tunnel-mounted. A between-the-seats sports console is optional. The Mustang's interior combines family practicality with sports appeal.

In the Mustang, Ford actually has created three different "personalities" to make it truly unlike any other production car ever to come off an American assembly line — an economical car . . . a high-performance car . . . or a high style luxury car geared either to economy of operation or to sports car performance. Low initial cost, coupled with high-style, easy and precise handling, excellent ride, a host of options, and a choice between high-performance and compact-car economy enable the Mustang to span several major segments of the new car market.

THE STYLING OF THE MUSTANG

The front view of Mustang presents a honeycomb-type grille in gunmetal gray with the Mustang emblem "floating" in a rectangle at the center. The grille extends the sweep of the hood ahead of the single-mounted, seven-inch headlamps, and small scoop lines in the sheet metal fairing emphasize the forward thrust. Bright metal molding is used at the sides and bottom of the grille. FORD in bright metal block letters at the hood leading edge provides attractive product identification from the front. The wing-shaped, wrap-around front bumper and standard-equipment bumper guards repeat the thrusting plan view of the hood. The turn signal/parking lights and license plate are located in the panel below the bumper. The front lower panel is made of galvanized steel for corrosion resistance.

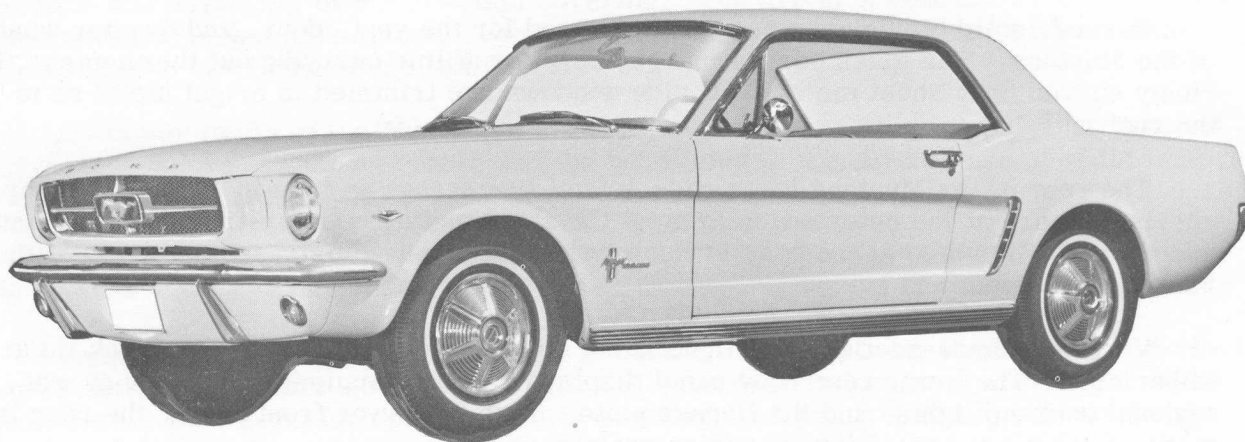

THE STYLING OF THE MUSTANG

The sporty windshield is raked 52-1/2 degrees. The windshield is framed in bright metal widened at the sides to accent the rake of the windshield. Curvature of the glass is held to a minimum and presents an excellent windshield wiper pattern. The 15-inch wiper blades sweep far into the corner areas of the windshield to help eliminate the typical driver's "blind" corner at the "A" pillar.

The Mustang has a look of performance. This is evident in the Mustang's new low center of gravity which presents a low profile view with sports car proportions. The long thrusting hood and the extremely compact rear deck, both with short overhang, further suggest sports car design. The length of the Mustang is accentuated by a sculptured side area.

The Mustang emblem and MUSTANG block letters in bright metal behind the front wheel opening identify the car.

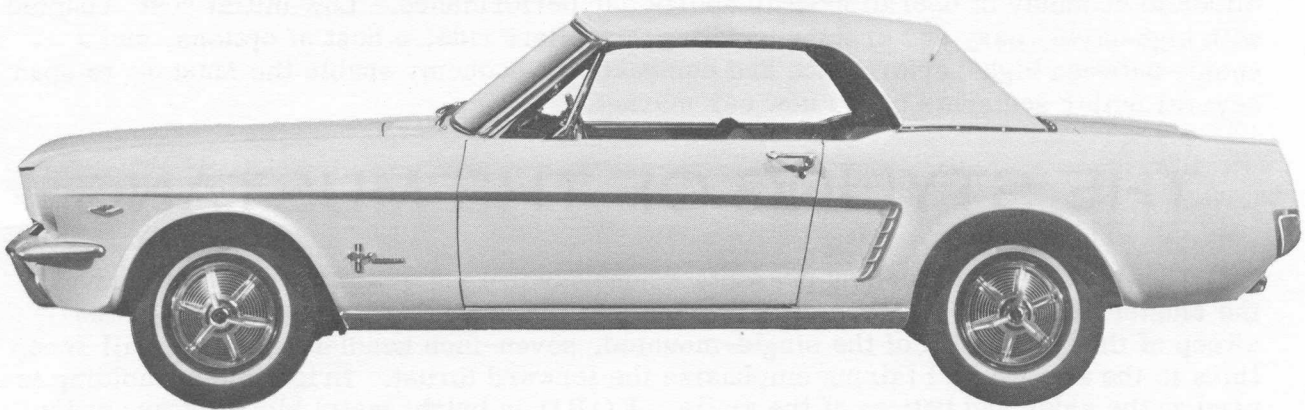

On models equipped with V-8 engines, a wide "V" incorporating "260" - "289" - or "289 High-Performance" is mounted on the front fenders ahead of the wheel-openings.

The wheel-openings are circular to expose the wheels fully. Stainless steel wheel covers are standard equipment and feature flat, simulated spokes on a background of bright rings. Simulated knock-off hubs mounted over the center of the wheel covers are optional.

Curved, solid tempered safety glass is used for the vent, door, and quarter windows of the Mustang. The glass curves into the upper roof line carrying out the theme of the richly curved body sheet metal. All side windows are trimmed in bright metal as is the roof rail drip molding on the hardtop model.

The rear of the Mustang has a wide, clean appearance with an integrated bumper curving upward at the outer edges to meet the sheet metal. Center-fill fueling is standard, and the gas filler tube at the body lower panel has a bright-finish, screw-on cap with the Mustang ornament and script.

Vertical, three-sectional taillights/turn signals are located below the deck lid at either side. The lower rear body panel displays standard equipment bumper guards, optional back-up lights, and the license plate. Like the lower front panel, the rear is made of galvanized steel for corrosion resistance.

THE STYLING OF THE MUSTANG



The Mustang's two-plus-two seating features front bucket seats with foam-padded cushions and backs and bright side shields. The seats are of sports car design and sculptured to provide good body support for greater seating security and comfort. Color-keyed front seat belts are standard. The sewn-in pleats of the seat inserts add to the comfort and durability of the all-vinyl covering. The driver's seat allows a 4 1/2-inch fore-and-aft manual adjustment. The rear bench seat is bucket-styled with sewn-in pleats for the vinyl covering of the insert areas.

All major items of the Mustang's interior are color-keyed to the buyer's choice of upholstery colors. The sun visors and the headlining in the hardtop are of white textured vinyl which emphasizes the spaciousness of the interior.

For durability and long-lasting appearance, the nylon - rayon deep-pile carpeting is molded to the contour of the floor.

Unique leather-textured sheet metal is used for durable inner door panels. A vinyl-covered trim panel through the mid-section of each door is bordered with bright mylar. Arm rests, positioned for optimum riding comfort, are safety-padded and have bright trim at the sides.

THE STYLING OF THE MUSTANG

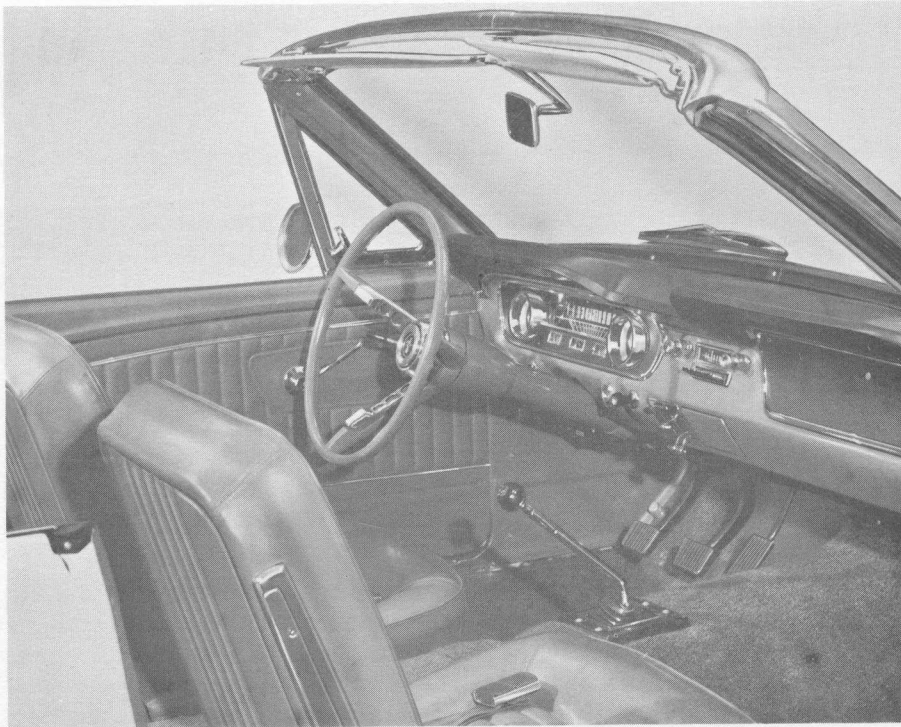

An unusual feeling of space is evident to both driver and front seat passenger because of the forward location of the instrument panel. Instrument panel ornamentation includes "engine-turned" bezels around the twin circular dials. The speedometer is graduated in 5 mph increments up to 120 mph. The sheet metal portion of the instrument panel and the glove compartment door are a "camera case" black crackle finish to help reduce glare. A safety-padded dash is standard.

In addition to suspended brake and clutch pedals, the accelerator also is suspended. The dual pivot action of the pedal improves foot comfort — especially for women wearing high heels — and provides smooth and easy power application.

POWER TEAM SELECTION

Four engines and three transmissions provide eight power team combinations for a wide choice of economy or performance. The standard power team — the "170" Six with three-speed manual transmission — provides low initial cost, maximum operating economy and good performance. Three optional V-8 engines are offered — the Mustang "260" V-8 at 164 horsepower, the Mustang "289" V-8 at 210 horsepower, and the Mustang "289" High-Performance V-8* at 271 horsepower.

Ford's three-speed Cruise-O-Matic transmission is optional with all engines except the "289" High-Performance V-8. For those who want a "fun-to-drive" car or maximum road performance, the all-synchronized four-speed manual transmission is available with all engines except the "260" V-8. Three-speed manual transmissions are standard equipment with the "170" Six and "260" V-8.

POWER TEAM SELECTION CHART

ENGINES	TRANSMISSIONS			REAR AXLE RATIOS		
	3-Spd. Manual	4-Spd. Manual	Cruise-O- Matic	3-Spd. Manual	4-Spd. Manual	Cruise-O- Matic
"170" Six - Std.	Std.	Opt.	Opt.	3.20(1) 3.50(2)	3.50	3.20(1) 3.50(2)
"260" V-8 - Opt.	Std.	N/A	Opt.	3.00	N/A	3.00
"289" V-8 - Opt.	N/A	Opt.	Opt.	N/A	3.00	3.00
*"289" V-8 - Opt. Hi-Performance	N/A	Opt.	N/A	N/A	3.89 4.11	N/A

- (1) Hardtop
- (2) Convertible

*Available shortly after introduction.

MUSTANG ENGINES

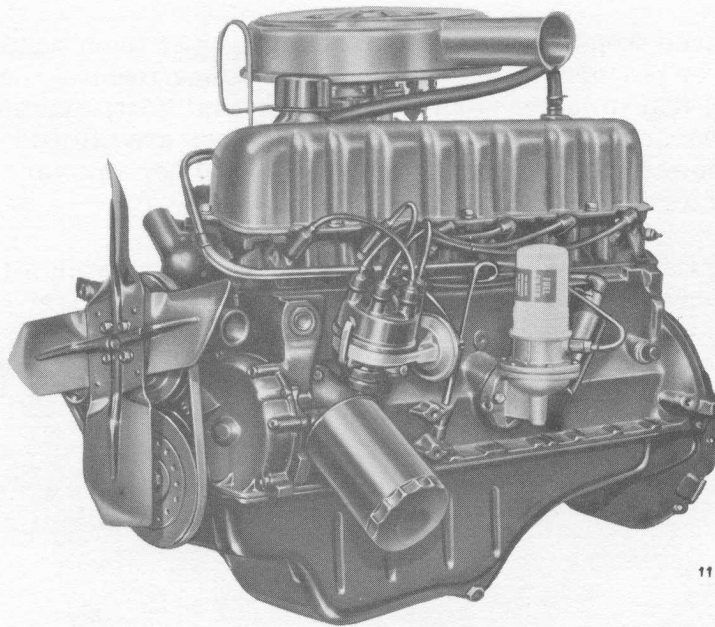

"170" SIX ENGINE

MUSTANG "170" SIX — Most economical of all Mustang engines, this standard equipment power plant provides sufficient power and performance to meet the needs of most motorists — for both city and country driving.

Included at no extra cost are the many service-saving features that permit Ford's famous Twice-a-Year maintenance — 6,000 mile oil filter . . . 36,000 mile fuel filter . . . 36,000 mile air filter . . . 36,000 mile, or two year, all-weather coolant . . . recommended 6,000 mile oil change interval . . . self-cleaning spark plugs . . . and hydraulic valve lifters.

Construction features include:

- Precision thin-wall cast-iron block and heads
- Automatic choke
- Single-venturi carburetor
- Integral cylinder head and intake manifold
- Water-warmed carburetor spacer
- High-turbulence wedge-shape combustion chambers
- Full-flow oil filter
- 190-degree thermostat

BASIC SPECIFICATIONS

Type	6-cylinder, in-line overhead valve
Displacement	170.0 cu. in.
Bore and stroke (Inches)	3.50 x 2.94
Compression Ratio	8.7 to 1
Brake Horsepower at 4400 rpm	101
Maximum Torque at 2400 rpm (lbs.-ft.)	156
Valve Lifters	Hydraulic
Carburetor	Automatic choke, single-venturi
Fuel	Regular

MUSTANG ENGINES

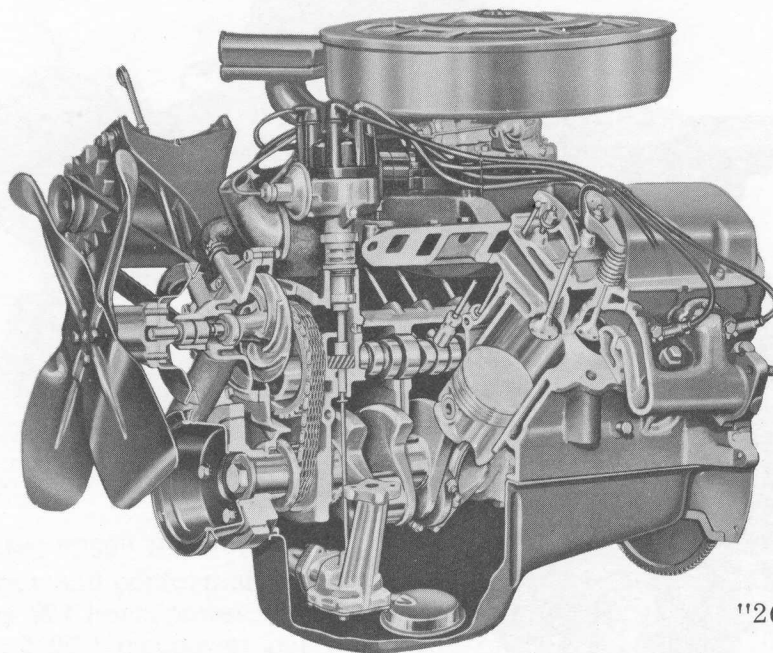

"260" V-8 ENGINE

MUSTANG "260" V-8 — This optional V-8 engine provides added power with V-8 smoothness, while retaining good economy characteristics. When equipped with the optional Cruise-O-Matic transmission, it gives good performance and driver convenience.

The Mustang "260" V-8 is designed around a short, low block — a compact design made possible through Ford's precision casting techniques which eliminate excess weight without sacrificing strength or rigidity. How well this concept has succeeded is shown by the various sports cars that now use Ford engines with this basic block.

The Mustang "260" V-8 also includes all of Ford's low-maintenance service-saving features.

The "260" V-8 also features dual advance centrifugal-vacuum distributor for precise spark control; short-stroke design for less wear and friction; dual air intake with bi-metal valve that controls air inlet temperature; vacuum-piston choke and heater coolant line adjacent to choke bi-metal spring for positive yet sensitive choke control; and full-length, full-circle water jackets — all adding up to top performance for thousands of miles.

BASIC SPECIFICATIONS

Type	8-cylinder, 90° V, overhead valve
Displacement	260 cu. in.
Bore and Stroke (Inches)	3.80 x 2.87
Compression Ratio	8.8 to 1
Brake Horsepower at 4400 rpm	164
Maximum Torque at 2200 rpm (lbs.-ft.)	258
Valve Lifters	Hydraulic
Carburetor	Automatic choke, 2-venturi
Fuel	Regular

MUSTANG ENGINES

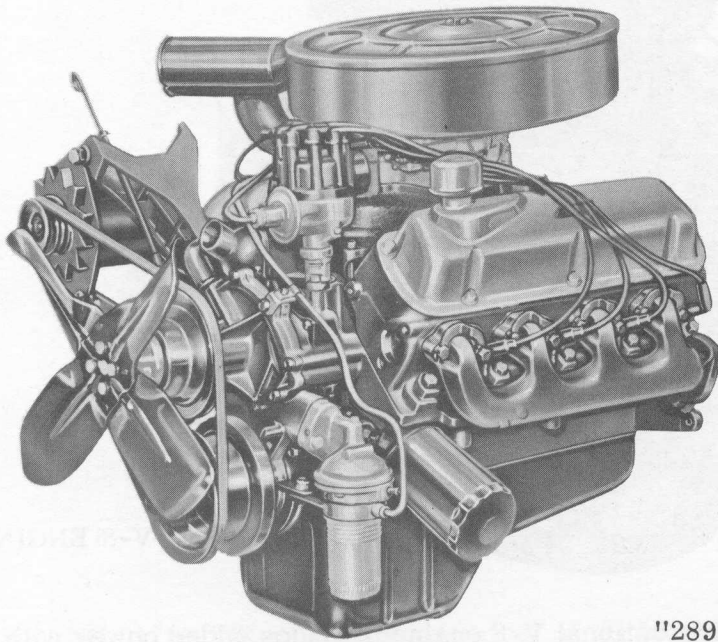

"289" V-8 ENGINE

MUSTANG "289" V-8 — The largest of the 260-cubic-inch family, the Mustang "289" V-8 develops 210 horsepower. In addition to larger displacement, it features a four-venturi carburetor, increased compression, and greater valve overlap.

This engine offers rapid acceleration as well as plenty of reserve power for high-way passing.

Except for its larger size and use of a four-venturi carburetor, the construction features of the Mustang "289" are similar to those of the Mustang "260" V-8.

BASIC SPECIFICATIONS

Type	8-cylinder, 90° V, overhead valve
Displacement	289 cu. in.
Bore and Stroke (Inches)	4.00 x 2.87
Compression Ratio	9.0 to 1
Brake Horsepower at 4400 rpm	210
Maximum Torque at 2400 rpm (lbs.-ft.)	300
Valve Lifters	Hydraulic
Carburetor	Automatic choke, 4-venturi
Fuel	Regular

MUSTANG ENGINES

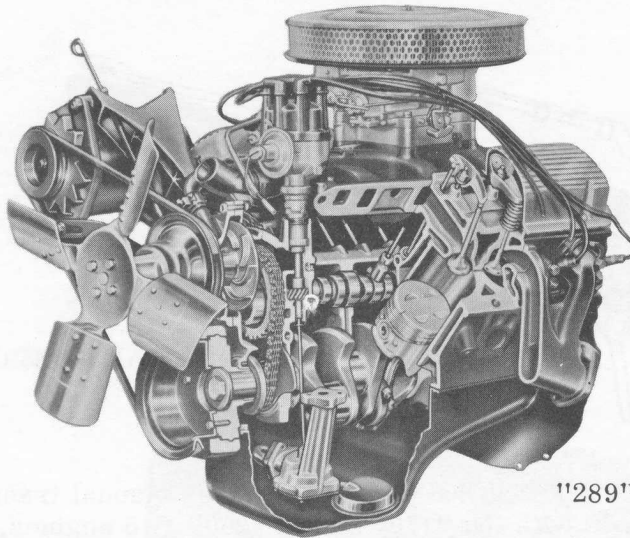

"289" HIGH-PERFORMANCE V-8

MUSTANG "289" HIGH-PERFORMANCE V-8 — Available to those who want outstanding power and performance characteristics, the Mustang "289" High-Performance V-8 develops 271 horsepower. It has a weight of less than two pounds per horsepower and delivers 0.95 horsepower per cubic inch of displacement — figures that reflect the engineering "know-how" built into this engine.

This is not simply a "hopped-up" version of the basic "289" V-8; rather, it is a special engine that includes reliability and durability to match its performance. All engine parts have been carefully designed and tested to withstand the extra stresses of high-performance usage.

Some of the special features of the Mustang "289" High-Performance V-8 engine are:

- High-compression cylinder heads — 10.5:1
- High-performance camshaft — high lift, long overlap
- Special extra-strength connecting rods
- Copper-lead alloy bearings — high load capacity
- Chrome-plated valve stems — greater durability
- Individual exhaust headers — free-flow design
- Free-breathing intake system — special 4-barrel carburetor, tuned low-restriction air cleaners, direct intake manifold passages
- Solid valve lifters — precise valve action
- Dual "header" exhaust system — minimum restriction

BASIC SPECIFICATIONS

Type	8-cylinder, 90° V, overhead valve
Bore and Stroke (Inches)	4.00 x 2.87
Compression Ratio	10.5 to 1
Displacement	289 cu. in.
Brake Horsepower at 6000 rpm	271
Maximum Torque at 3400 rpm (lbs.-ft.)	312
Valve Lifters	Solid
Carburetor	Automatic choke, 4-venturi
Fuel	Premium

MUSTANG TRANSMISSIONS

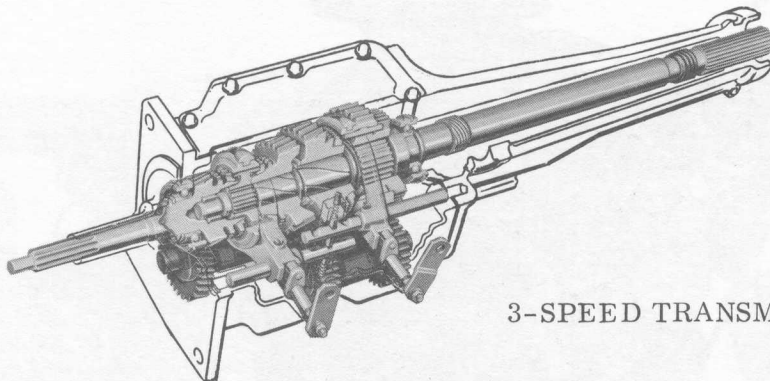

3-SPEED TRANSMISSION

THREE-SPEED MANUAL TRANSMISSIONS — A three-speed manual transmission is standard on all Mustangs equipped with the "170" Six or "260" V-8 engines. The transmission used with the "170" Six is synchronized in 2nd and 3rd gears, while that used with the 260 V-8 is synchronized in all forward gears. Both transmissions feature floor shifts, rugged cast-iron case construction, heavy-duty anti-friction bearings, helical gears, and gear ratios matched to engine outputs.

The all-synchronized, constant-mesh transmission used with the "260" V-8 is Ford pioneered in the United States, and provides greater driving flexibility through maximum utilization of all gears. Upshifts and downshifts — even down to 1st gear while the car is under way — can be accomplished smoothly and quickly, eliminating double clutching and gear clash.

Both transmissions are filled at the factory with Life-of-Car gear lubricant.

Gear Ratios		
	"170" Six	"260" V-8
First	3.29:1	2.79:1
Second	1.83:1	1.70:1
Third	1.00:1	1.00:1
Reverse	4.46:1	2.87:1

FOUR-SPEED TRANSMISSIONS — Available with the "170" Six and both "289" V-8 engines, four-speed transmissions offer the maximum in driving flexibility and road performance. The four closely spaced gear ratios take full advantage of the engine torque, matching power and rpm to terrain and driving conditions. In addition, full synchronization of all forward gears permits split-second shifting for maximum driver control.

Both transmissions are Ford-built and designed for long-life and rugged durability. Heavy-duty gears, bearings and cast-iron case construction permit extended operation in any gear ratio.

The gearshift lever is tunnel-mounted, and the shift pattern follows the international standard arrangement.

MUSTANG TRANSMISSIONS

4-SPEED TRANSMISSION

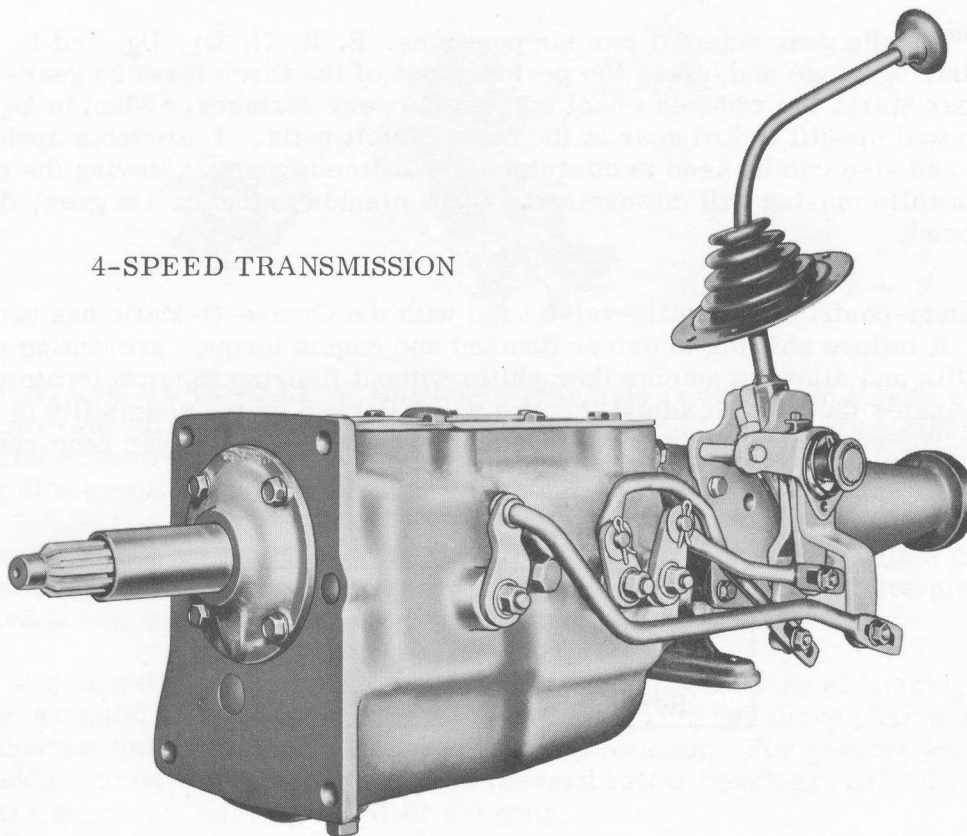

Gear Ratios		
	"170" Six	"289" V-8
First	3.16:1	2.78:1
Second	2.21:1	1.93:1
Third	1.41:1	1.36:1
Fourth	1.00:1	1.00:1
Reverse	3.35:1	2.78:1

CRUISE-O-MATIC TRANSMISSION — For those desiring the convenience of an automatic, the Mustang can be obtained with Ford's latest three-speed Cruise-O-Matic transmission. Available with all engines except the "289" High-Performance, this premium grade automatic combines torque-converter starts, three forward gear ratios, two driving ranges, vacuum operated throttle valve, tunnel-mounted gear selector, and positive parking lock. The "T" handle gear selector lever features a thumb-operated reverse gear lock button.

The precision-cast aluminum converter housing and transmission case enclose the three-element torque converter and two planetary gear sets. Two clutches, two bands, and a one-way clutch are used to achieve gear changes.

MUSTANG TRANSMISSIONS

The "T" handle gear selector has six positions, P, R, N, D₁, D₂, and L. D₁ is the normal driving range and offers the performance of the three forward gears. D₂ offers 2nd gear starts for reduced wheel spin on slippery surfaces. When in D₂, the transmission will upshift to 3rd gear at the normal shift point. L prevents upshifts out of first gear and also can be used to advantage for engine braking. Moving the gear selector to L while moving will downshift the transmission to 2nd or 1st gear, depending on car speed.

The vacuum-controlled throttle-valve used with the Cruise-O-Matic has two major advantages. It tailors shifting to driver demand and engine torque, preventing premature upshifts and allowing smooth downshifts without flooring the accelerator pedal. Also, it eliminates the need to adjust throttle valve linkage or the possibility of mal-adjustment. The vacuum throttle valve mechanism is preset and never requires adjustment.

Gear Ratios	
First	2.46:1
Second	1.46:1
Third	1.00:1
Reverse	2.20:1

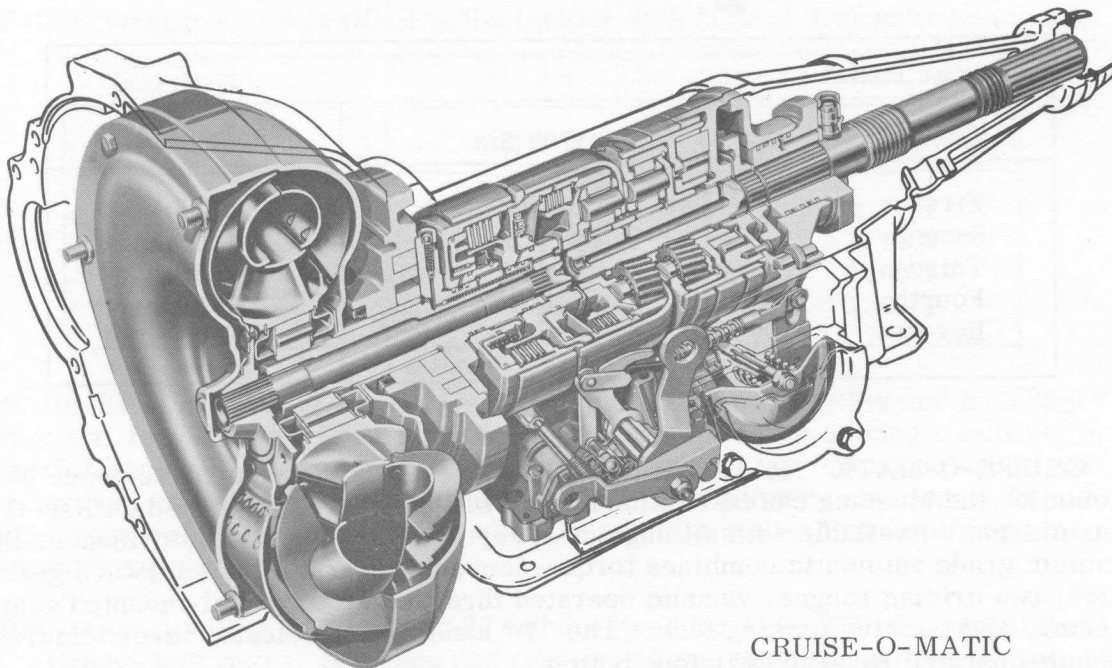

CRUISE-O-MATIC

MUSTANG REAR AXLE AND DRIVE LINE

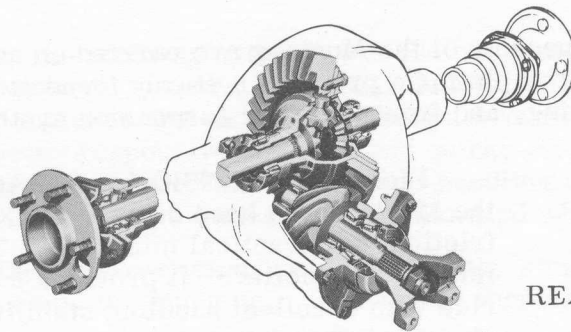

REAR-AXLE — V-8 MODELS

MUSTANG REAR AXLE — Mustang's rear axle is of the semifloating, hypoid type to provide quiet, efficient power flow. Rear axles for both six cylinder and V-8 engines feature deep-offset pinion gears for maximum tooth contact, and roller bearing differentials for longer, more trouble-free operation.

When equipped with a "170" Six, the Mustang uses a rear axle with a differential housing of cast-iron, welded to pressed steel axle housings. The drive pinion is supported in two tapered roller bearings ahead of the gear.

On V-8 models, the rear axle uses a banjo-type pressed-steel housing and a straddle-mounted drive pinion. The differential carrier and drive gear assembly use a separate unit bolted to the front side of the housing. For greater load capacity the straddle-mounted pinion features two tapered roller bearings AHEAD of the gear and a straight roller bearing BEHIND the gear.

Shortly after introduction an optional Equa-Lock differential will be offered. With this type of design, built-in clutch plates transfer part of the usable drive torque to the wheel with the most traction.

REAR AXLE SPECIFICATIONS

	Six-Cylinder Engine	V-8 Engines
Type	Hypoid, semifloating	
Housing	Malleable iron, integral carrier	Pressed steel, removable carrier
Drive Type	Hotchkiss	
Differential	Deep offset, hypoid	
Axle Shafts	Induction-hardened steel forgings	
Wheel Bearings	Double-sealed, ball-type permanently lubricated	

DRIVE SHAFT AND UNIVERSAL JOINTS — The Mustang has a Hotchkiss-type drive system with an exposed seamless tube drive shaft. The drive shaft has cross-and-yoke-type universal joints at both ends. For smooth, dependable operation the drive shaft is precision balanced after manufacture and the universal joints use roller-needle bearings at all friction points.

MUSTANG CHASSIS

The main chassis components of the Mustang are carried on an extremely rigid, all-welded steel platform. The platform provides a sturdy foundation for attaching the engine, transmission, steering, and front and rear suspension systems.

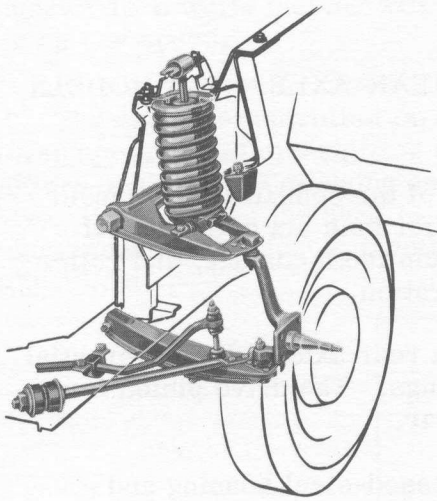

FRONT SUSPENSION

FRONT SUSPENSION — The front suspension of the Mustang has been designed to keep the inherent friction to a practical minimum. This has two important benefits — it provides a smooth, big-car ride with excellent handling stability, and it reduces steering effort for easier, more precise control.

The front suspension is independent ball-joint, with single lower arms and A-frame upper arms. Both upper and lower arms are attached to the body with threaded bushings, lubricated for the life of the car. The coil spring is cushioned in rubber — at the top with a circular rubber mount, and at the bottom with a rubber-bushed pivot.

The lower control arm is connected to the underbody with two large, resilient rubber bushings. These bushings permit a slight, controlled, horizontal wheel movement that helps cushion small road irregularities, especially at higher speeds. A rubber bushed sway bar provides effective sway control.

REAR SUSPENSION — The rear suspension fully complements the smooth, comfortable ride of the front suspension. The long, wide rear springs cushion bumps smoothly and quietly, and special spring tip liners reduce friction to absorb even small bumps.

A large, resilient rubber bushing at the front mounting eye reduces road shock and noise and permits slight horizontal wheel movement to absorb small irregularities. The rear of the spring is held in a rubber bushed compression-type shackle, allowing easy flexing on light impact and providing greater resistance to severe impact.

The angle-mounted shock absorbers add stability to the Mustang's ride, reducing side sway for safer driver control.

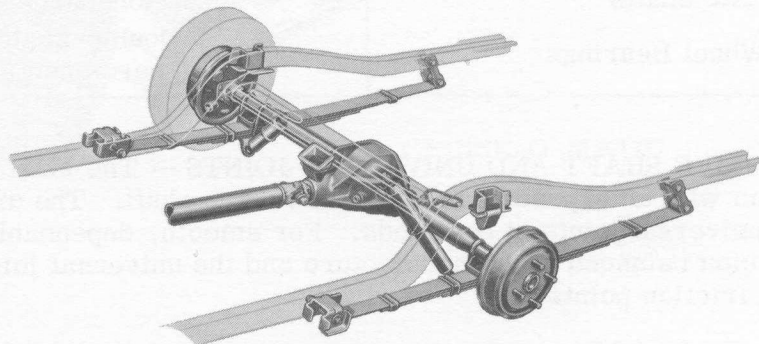

REAR SUSPENSION

MUSTANG CHASSIS

STEERING — The steering system is of the parallelogram-linkage type, with a cross link and idler arm. Ford's Magic-Circle recirculating ball-and-nut steering gear is used, and features anti-friction bearings throughout. The overall ratio of 27 to 1 gives smooth, responsive steering and quick, effortless full-circle turns. For those desiring faster steering, an optional handling package includes a gear providing a ratio of 22 to 1. The faster ratio is standard with power steering.

BRAKES — Duo-servo-design, self-energizing, single-anchor, internal-expanding brakes are used on the Mustang. They adjust themselves if required when applied while backing.

The brakes are designed to reduce "fade" and provide longer life. The rear wheel parking brakes are operated by cables connected to a T-handle under the left side of the instrument panel.

CHASSIS SPECIFICATIONS	
Front Suspension	
Type	Independent with ball-joints and sway bar
Springs	Helical coil, rubber insulated top and bottom
Shock Absorbers	Hydraulic, telescopic, vertical-mount
Rear Suspension	
Type	Variable-rate semi-elliptic leaf springs with rubber bushed hangers
Number of Leaves	3
Leaf Length & Width	53 x 2.50
Spring Shackles	Compression-type
Shock Absorbers	Hydraulic, telescopic, angle-mounted
Steering Specifications	
Type	Parallelogram with cross link and idler arm
Gear Type	Magic-Circle recirculating ball
Overall Steering Ratio	27:1
Turning Dia. (Curb-to-Curb)	38.0 ft.
Steering Wheel Dia.	16.0 inches
Wheels	
Type	Stamped steel disc with safety rims
Number of Studs	4
Dia. and Rim Size	13 x 4.5
Tires	
Size	6.50 x 13
Brakes	
Brake Drum Dia.	9" (10" V-8 models)
Lining Material	Molded Asbestos
Lining Attachment	Riveted
Total Lining Area Gross (Sq. In.)	131.0 (154.2 V-8 models)

MUSTANG BODIES

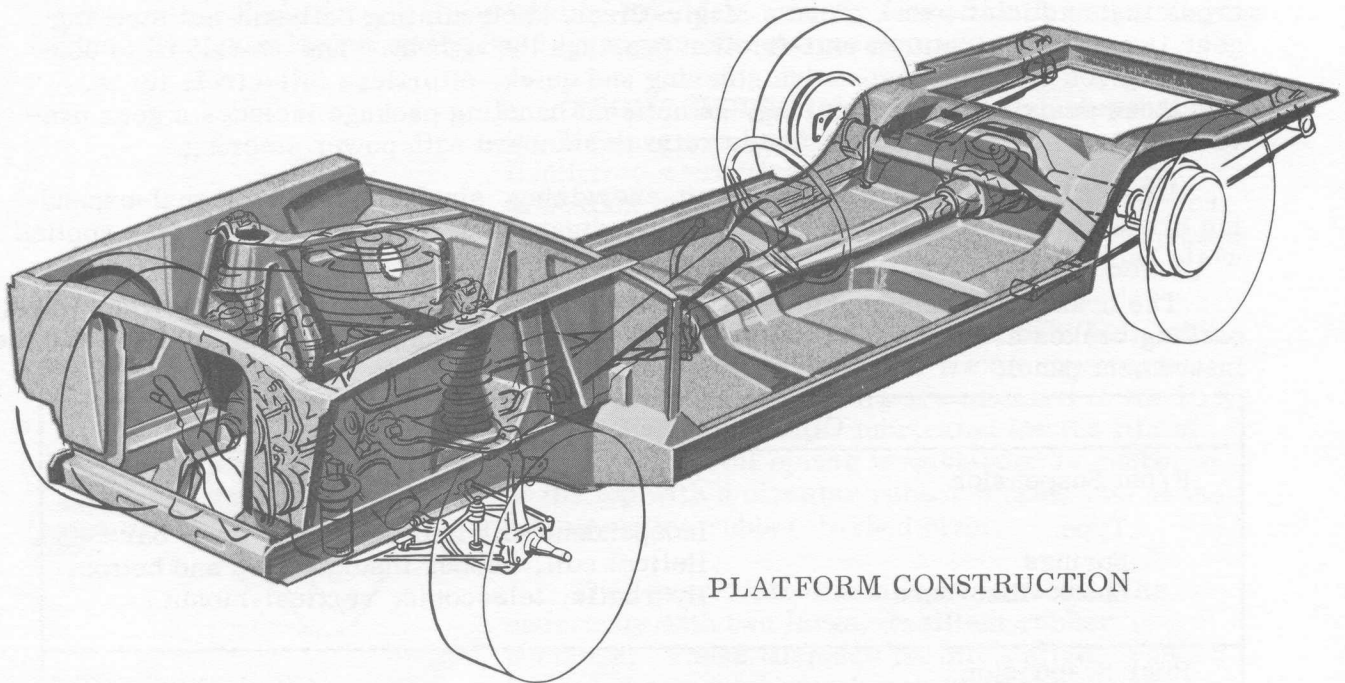

BODY CONSTRUCTION — The all-new body of the Mustang was designed and engineered to provide maximum strength with minimum weight. The body is an all-welded structure carried on a platform-type chassis. The two are joined by welding for maximum durability and to help reduce body squeaks and rattles.

The platform consists of box-section front and rear side rails tied in securely to heavy boxed-in rocker panels. Five heavy gage cross-members connect these basic platform components to form a ladder-type framing beneath the car. The front and rear side rails extend partially under, and are welded to, the floor pan. The full-depth, full-length tunnel in the floor pan adds a "backbone" to help make the platform rigid.

In the engine compartment, the full-depth side panels are welded to the front side rails at the bottom and to the cowl at the rear. The top of the side panels are pressed over to form a wide flange, adding further to front end rigidity. The side panels are connected across the front with a one-piece stamping that has a deep channel-section at the top. The front fenders are bolted on for easy replacement.

All framing around body openings and the roof bracing on the hardtop model are of either box, channel or hat section design. All structural members and panels are made from large stampings to reduce the number of small welded assemblies. Both the hardtop and convertible bodies are essentially the same, except that certain underbody members on convertibles use heavier-gage steel to compensate for absence of the roof structure.

MUSTANG BODIES

CORROSION PROTECTION — Zinclad coating of main underbody members and extensive use of zinc-rich primer are employed to retard rust and corrosion. A heavy coating of metallic zinc is applied to the front side rails, rocker panels, rear side rails and the front and rear panels beneath the bumpers. Zinc-rich primer is applied to the lower interior surfaces of the various body panels, doors, fenders and pillars, and to splash areas of the wheel housings.

HOOD AND DECK LID — The hood and deck lid are double panel structures welded completely around the outer edge. The inner panels are stamped to form channel-section braces around the edges and at strategic angles through the center. The hood features counterbalanced hinges and a single-action hood release with a safety catch. The hood release is located between the grille and bumper at the center. The deck lid features a key-operated latch and torsion-bar-assisted hinges to permit, easy one-hand opening.

The hardtop luggage compartment has 8.8 cubic feet of usable luggage capacity, with slightly less in convertible models. The compartment floor is covered with an attractive, plaid-patterned mat, and the spare tire is located at the right rear. The spare tire, jack and wheel lug wrench are held firmly in place by a large wing nut. The jack is a mechanical scissors-type and, when used, fits into specially designed recesses under the side of the car. A ratchet action lug wrench provides easy jack operation and wheel lug nut removal.

DOORS — The wide-opening doors of the Mustang are of double-panel welded steel construction with rolled outer edges to form a sturdy box structure. The strap-type hinges have bronze bushings for long wear and more effortless opening and closing. The lower door hinges have automatic assist springs for help in swinging the doors open and two-stage door checks that hold the doors in partial or full-open position.

The door garnish molding and scuff plate are built into the inner panel, eliminating unnecessary parts and allowing thin-wall design. Bear-Hug door latches — pioneered and exclusive with Ford products — make the doors easy to open and close, are designed to reduce the chance of opening on impact, and provide quiet, rattle-resistant operation.

WINDOWS — Safety glass is used in all Mustang windows. Laminated safety glass is used in the windshield, and solid tempered glass in the curved side and rear windows (except convertibles, which have crystal vinyl rear windows).

CONVERTIBLE TOP — Convertibles feature a sturdy, manually operated top designed especially for the Mustang. The top mechanism raises and lowers quickly and almost effortlessly with assistance of carefully placed, counterbalance springs located in cylinders attached to the floor pan and mounted to provide correct leverage through precise arc of travel. An electro-hydraulic power top is optional.

The latches used to hold the top to the windshield header have a high leverage ratio, providing quick, low-effort operation. The latches are located on the top side rails and are almost flush when in the locked position. From the inside in the up position, the Mustang convertible top presents a clean uncluttered look, with a minimum of linkage in the rear seat area. Like all Ford convertibles, the top material is permanently attached to the roof bows, preventing unsightly "ballooning" when traveling at highway speeds.

The top is available in black, white or blue vinyl. A foam-padded stretch-vinyl boot, color-keyed to the interior, snaps in place over the folded top.

MUSTANG BODIES

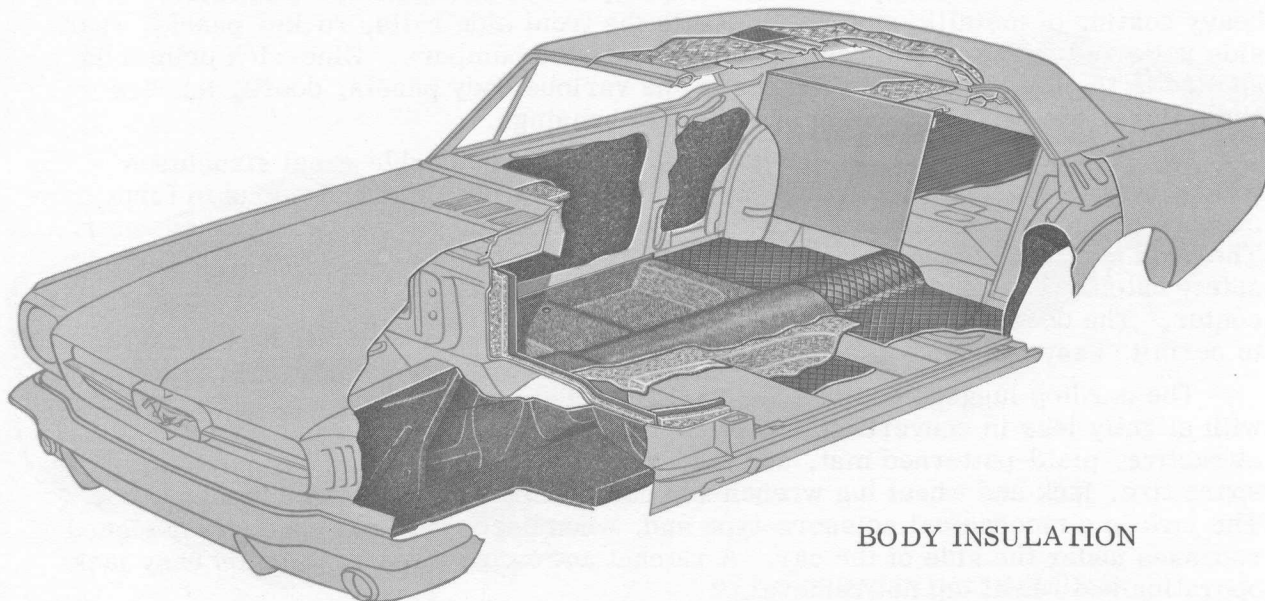

BODY INSULATION

MUSTANG INSULATION AND SOUND-DEADENING — The passenger compartment of all Mustangs is surrounded by a variety of specially selected insulating and sound-deadening materials, shielding occupants from road and engine noise and providing better protection against weather extremes.

The floor areas alone have a triple thickness of insulating material — a heavy waffle-textured mat, a jute pad, and nylon-rayon carpeting. The front dash panel is covered with a molded insulation of heavy amberlite between asphalt impregnated facing board. On hardtop models, the entire roof panel is insulated with a thick blanket of fiberglass. These are a few of the major items. In addition, many other areas are insulated and sealed with generous amounts of fiberglass, amberlite, sprayed-on sound deadeners, grommets, seals and plastic joint sealers.

SPECIFICATIONS

DIMENSIONS AND WEIGHT		
General Dimensions	Hardtop	Convertible
Length — Overall	181.6	181.6
Height — Overall	51.1	51.0
Width — Overall	68.0	68.0
Wheelbase	108.0	108.0
Tread — Front (6-Cyl.)	55.4	55.4
— Front (V-8)	56.0	56.0
— Rear	56.0	56.0
Curb Weight — 6-Cyl. Manual	2585	2755
Usable Luggage Capacity	8.8	N/A
Interior Dimensions		
Front		
Headroom	37.5	37.7
Shoulder Room	53.8	53.8
Effective Leg Room	40.9	40.9
Hip Room	54.7	54.7
Rear		
Headroom	35.4	35.8
Shoulder Room	53.9	43.4
Minimum Knee Room	2.1	2.1
Hip Room	50.6	43.7

TRIM AND COLOR COMBINATIONS						
Exterior Color	Interior (All Vinyl)					*Cloth & Vinyl
	Black	Red	Blue	Palomino	White	Black
Raven Black	X	X		X	X	X
Wimbledon White	X	X	X	X	X	X
Rangoon Red	X	X		X	X	X
Silver Smoke Grey	X	X			X	X
Guardsman Blue			X		X	
Skylight Blue			X		X	
Caspian Blue			X		X	
Dynasty Green	X				X	X
Chantilly Beige	X				X	X
Vintage Burgundy	X			X	X	X
Prairie Bronze	X	X		X	X	X
Samoan Coral	X				X	X
Red Metallic	X			X	X	X
Pagoda Green	X				X	X
Chrome Yellow	X			X	X	X
Convertible Tops:	Black or White for all Body Colors and Trim. Blue for Blue Trim in White or Blue Body Color.					
Hardtop Vinyl Tops:	Black or White with any exterior color.					

*Hardtop Only

MUSTANG

STANDARD EQUIPMENT FEATURES

STANDARD EQUIPMENT FEATURES

Accelerator Pedal — Suspended type

Arm Rests — Front

Ash Tray — Front

Body — Platform-unitized, rust-resistant, fully insulated

Brakes — Self-adjusting

Bucket Seats — Front, foam-padded

Carpets, Front and Rear — Molded nylon-rayon

Cigarette Lighter

Convertible Top — Manual, easy-action latches

Courtesy Light — Door switches

Curved Side Glass

Door Checks — Two stage

Door Latches — Bear-Hug safety type

Engine — 170 Special Six

Front Fenders — Bolt-on

Fuel Tank — 16 gallon

Glove Box Light

Headlining — All vinyl

Heater and Defroster — Fresh-air

Hood and Rear Deck Lid — Counterbalanced hinges

Hood Latch — Single-action, safety-type

Interior Detail —

Painted Color-Keyed Items:

Quarter trim panels, instrument panel, defroster and radio speaker, grille, ash tray cover, steering column assembly, door garnish molding, and scuff panel, "A" pillar, "A" pillar upper headlining molding.

STANDARD EQUIPMENT FEATURES

(continued)

Color-Keyed Items:

Floor carpeting, cowl trim panel, windcord, door lock buttons, seat belts, steering wheel, seats, door trim panels.

Bright-Finish Items:

Gear shift lever, convertible header molding, rear view mirror assembly, sun visor bracket and arm, turn signal lever and knob window regulators, door handles, dashboard control knobs, seat side shields, instrument bezels.

Jack, Scissors-Type — Body side jacking

Lubrication, Chassis — 36,000 mile

Maintenance — Twice-A-Year or 6,000 mile

Mirror — Rear view

Molding, Windshield and Backlite — Full bright metal

Padded Instrument Panel

Scuff Plates — Aluminum

Seat Belts — Color-keyed, metal-to-webbing

Steering Wheel — Deep-dish, safety-type

Sun Visors — Dual

Transmission Lever — Tunnel-Mounted

Upholstery — All vinyl

Wheel Cover — Stainless steel full bright metal

Windshield Wipers — Extra-wide parallel action

MUSTANG OPTIONS AND ACCESSORIES

FACTORY-INSTALLED OPTIONS AND ACCESSORIES

Like other Ford cars, the new and different Mustang can be ordered with a wide variety of options and accessories to suit individual comfort, convenience and appearance preferences. However, the Mustang's choice of options and accessories are so extensive that certain high-performance options can be used to change the entire character of the car.

With standard equipment, the Mustang is an economical, fun-to-drive car with all-weather comfort and unique styling. With addition of a few well-designed options, it becomes a high-performance action car with precise handling and rapid acceleration, but with its basic features and appearance unchanged.

Between these extremes of economy and performance, other options provide varying levels of horsepower, comfort, luxury — or combinations of all three! Thus, with a selection of options, the Mustang can be molded to fit the individual tastes and desires of every buyer.

The factory-installed options and accessories available for the Mustang are as follows:

SPORTS CONSOLE — The full-length console further increases the sports flair of the tastefully styled interior, and should prove to be one of the "most-wanted" options of Mustang owners. The console is color-keyed to the interior, and is trimmed on the top with a bright metal applique with black "camera-case" finish inserts. It features a lighted storage compartment with room for driving accessories and an ash tray at the back for rear seat passengers. At the front, the console sweeps forward to integrate with the dash. Heater louvers at the front-sides provide proper heat distribution. The transmission shift lever extends through the console on all models. On Cruise-O-Matic equipped models, a bright metal plate showing the shift pattern is attached to the top surface.

SPECIAL HANDLING PACKAGE** — The special handling package is available for those who want the ultimate in fast, precise handling and roadability, or for those who intend to use the Mustang in competition. Included are increased rate front and rear springs, larger and recalibrated front and rear shock absorbers, an increased-diameter front stabilizer bar, a faster steering gear that results in a 22:1 overall steering ratio, and 14-inch tires and wheels with 5 inch rims.

SPORTS TIRES AND WHEELS** — The 15-inch sports tires and wheels are available only in combination with the special handling package. The 5.50/5.90 x 15 tires are designed for competition events, and feature special cord construction, rubber compounds, and tread design to increase stability, cornering and traction. Due to their special construction and higher inflation pressures, they are not recommended for normal street use. The tires are mounted on steel, disc-type wheels with 5-1/2-inch rims, and are available in black only.

POWER CONVERTIBLE TOP — A desirable convenience option, the power convertible top provides automatic raising and lowering of the top. A touch of the switch on the dash energizes the electro-hydraulic power unit for quick, dependable, smooth action.

MUSTANG OPTIONS AND ACCESSORIES

RALLY-PAC — Consisting of a clock and tachometer, the Rally-Pac is enclosed in a twin-pod housing with a black "camera case" finish and bright metal trim. It is attached to the steering column for convenience and quick viewing, and has night-time illumination. The precision tachometer is calibrated from 0 to 8000 rpm when Mustang is equipped with the "289" high-performance V-8, and from 0 to 6000 rpm when equipped with all other engines. The dial is marked in increments of 200 rpm with each 1000 rpm numbered. The clock has a full size sweep-second hand and Ford's special self-regulating feature. When the clock is reset, an internal mechanism also is actuated which speeds up or slows down the clock action as required. After being reset a few times, the clock will run very accurately and further resetting will not be necessary.

Air Conditioning

Arm Rest, Fold Down Center, Front Seat

Battery — Heavy Duty

Back-Up Lamps

Engines:

260 2V V-8

289 4V V-8

289 4V High-Performance V-8**

Glass — Tinted, with Banded Windshield

Windshield Only, Tinted and Banded

Knock-Off Hubs — Wheel Cover Trim

Locking Differential — All Ratios

Mirror, Outside Rear View

Padded Sun Visors

Power Brakes

Power Steering (22:1 Overall Ratio)

Radio, Push Button, with Antenna

Rocker Panel Molding

Seat Belts, Custom, Metal-to-Metal, with Retractors

Steering Wheel, Sports Deluxe

Tires — 6.50 x 13-4 ply rating WSW

7.00 x 13-4 ply rating BSW

7.00 x 13-4 ply rating WSW

6.50 x 14-4 ply rating BSW

6.50 x 14-4 ply rating WSW

Transmissions:

4-Speed Manual

3-Speed Cruise-O-Matic

Vinyl Roof — Black or White — Hardtop

Windshield Washers (Electric) — with Two-Speed Electric Wipers

In addition to the above factory-installed options, Ford dealers will offer a wide variety of specially designed dealer-installed accessories.

** Available shortly after introduction.

PUBLIC RELATIONS FIELD OFFICE LOCATIONS

Jack W. Clarke, Manager
Western Public Relations Office
Ford Motor Company
International Building
St. Mary's Square
San Francisco 8, California

H. Kenneth Gregory, Manager
Southern Public Relations Office
Ford Motor Company
1616 Rhodes-Haverty Building
Atlanta 3, Georgia

D. Robert Sturgiss, Manager
Midwest Public Relations Office
Ford Motor Company
One East Wacker Drive
Chicago 1, Illinois

George A. Haviland, Manager
Missouri Valley Public Relations Office
Ford Motor Company
1702 Power and Light Building
Kansas City 5, Missouri

Thomas J. Tierney, Manager
Southwest Public Relations Office
Ford Motor Company
718 Mercantile Continental Bldg.
Dallas 1, Texas

Russell M. Hart, Manager
North Central Public Relations Office
Ford Motor Company
903 East Ohio Building
1717 East Ninth Street
Cleveland 14, Ohio

Richard L. Hainline, Assistant Manager
Western Public Relations Office
Ford Motor Company
3921 Wilshire Boulevard
Los Angeles 5, California

John E. Sattler, Manager
Northeast Public Relations Office
Ford Motor Company
477 Madison Avenue
New York 22, New York

Roy J. Forrest, Manager
Washington Public Relations Office
Ford Motor Company
Wyatt Building
Washington 5, D.C.