

'78 Ford Fleet

CONFIDENTIAL
PREVIEW

PINTO



Pinto Pony Two-Door Sedan



Pinto Standard Cloth/Vinyl Interior Trim—
Shown with Black High-Back Bucket Seats



Pinto Three-Door Runabout with Optional Glass Third Door and Jade Half-Vinyl Roof



Pinto Standard Third Door



Pinto Squire Wagon



Pinto Optional Interior Decor Group Trim—
Shown in Alpine Plaid

NOTE: The description and specifications contained in this sheet were in effect at the time the publication was approved for printing. Ford, whose policy is one of continuous improvement, reserves the right to discontinue at any time, or change specifications or design without notice or without incurring obligations. All options and accessories illustrated or referred to as optional or available in this sheet are at extra cost.

PINTO — INDEX

GENERAL SECTIONS

1978 Highlights	2
Model Availability	3
Color and Trim Selections	4
Major Standard Features	5
Standard Equipment Summary	9
Selected Option Descriptions	10
Optional Equipment Summary	13
Chassis Features	16
Body Features	18
General Specifications	20

SPECIFIC FEATURES

Accent Tape Stripe	11
Air Conditioning	10
Body Construction	18
Body Sealing Material	19
Brake Specifications	21
Brakes, Front Disc/Rear Drum	17
Bucket Seats, 4-Way Adjustable	11
Cargo Area Cover	11
Convenience/Light Group	10
Cruising Wagon	12
Cruising Wagon Two-Tone Paint Treatment	12
Curb Weights	20
Dimensions/Specifications	20
Door Construction	19
Engine/Transmission/Axle Ratio Combinations	22
Exterior Decor Group	12
Glove Box	20
Heating System	19
Hood Construction	20
Insulation/Soundproofing	18
Interior Decor Group	12
Light, Liftgate Warning	19
Luggage Compartment	20
Mini-Console	19
Platform Construction	16
Protection Group	12
Radio, AM with Stereo Tape Player	12
Rallye Appearance Package	13
Rear Window Defroster, Electric	11
Roof, Flip-Up Open Air	10
Runabout Rear Door	19
Seat Construction	19
Sports Rallye Package	11
Squire Option	13
Steering, Power Rack and Pinion	17
Steering, Rack and Pinion	17
Steering Specifications	21
Sunroof, Manual	10
Suspension, Front	15
Suspension, Rear	15
Third Door	19
Tire Availability	21
Transmission, 4-Speed Manual	17
Ventilation System	19
Vinyl Roof	4
Wheel Covers	11
Wheel Covers, Wire	11
Wheel Specifications	21
Wheels, Forged Aluminum	11
Wheels, White Painted Forged Aluminum	11
Wheels, Styled Steel with Trim Rings	11
Window Construction	20

PINTO — 1978 HIGHLIGHTS

STANDARD FEATURES

- HD 45 amp.-hour battery (except in California)

OPTIONS

- Variable Ratio Power Rack-and-Pinion Steering
- AM Radio with Digital Clock
- Accent Tape Stripe
- White Painted Forged Aluminum Wheels



PINTO — MODEL AVAILABILITY

TWO-DOOR SEDAN

	Sales Code No.	Body Code No.
Two-Door Pony	10	62B
Two-Door Sedan	10	62B



**TWO-DOOR
SEDAN**

THREE-DOOR RUNABOUT

	Sales Code No.	Body Code No.
Three-Door Runabout	11	64B



**THREE-DOOR
RUNABOUT**

STATION WAGON

	Sales Code No.	Body Code No.
Station Wagon	12	73B



**STATION
WAGON**

PINTO — COLOR AND TRIM SELECTIONS

Exterior and interior color combinations shown as "available" have been established as most attractive to the average customer. Orders for combinations not shown may be submitted, provided the original order carries a notation stating the exterior and interior selection has been verified and is definitely desired. This procedure does not apply to orders specifying two-tone paint combinations or vinyl roof colors. Colors and codes referenced are the same as those shown in your Color and Trim Book.

PINTO																		
MODELS	2-DOOR SEDAN			3-DOOR RUNABOUT			STATION WAGON											
	ALL-VINYL L/B BUCKET (STANDARD)			CLOTH & VINYL L/B BUCKET (OPTIONAL)			INTERIOR DECOR GROUP											
							CLOTH & VINYL L/B BUCKET				ALL-VINYL L/B BUCKET							
	Chamois	Red	Blue	Black	Chamois	Jade	Red	Blue	Black	Chamois	Jade	Tangerine	Red	Blue	Black			
AT	AR	AD	AA	GT	GR	GD	GA	DT	DR	DI	DD	DB	HT	HR	HI	HD	HB	HA
EXTERIOR BODY COLORS																		
1G	Silver Metallic		*	*			*	*			*	*		*	*		*	*
2R	Bright Red		*	*			*	*			*	*		*	*		*	*
3G	Dark Blue Metallic		*	*			*	*			*	*		*	*		*	*
3U	Light Blue		*	*			*	*			*	*		*	*		*	*
34	Medium Blue		*	*			*	*			*	*		*	*		*	*
46	Dark Jade Metallic	*				*	*		*	*			*	*				
5M	Med. Chestnut Met.	*		*	*		*	*			*	*		*	*		*	*
5Q	Dark Brown Metallic	*		*	*		*	*			*	*		*	*		*	*
6E	Bright Yellow			*	*		*	*			*	*		*	*		*	*
7W	Medium Jade	*		*	*		*	*			*	*		*	*		*	*
8W*	Chamois Glow	*		*	*		*	*			*	*		*	*		*	*
83	Light Chamois	*		*	*		*	*			*	*		*	*		*	*
85	Tangerine			*	*		*	*			*	*		*	*		*	*
9D	Polar White	*	*	*	*	*	*	*	*	*	*	*	*	*	*	*	*	*

*RPO

VINYL ROOF COLOR AVAILABILITY													
ROOF COLOR	HALF-ROOF VALINO GRAIN												
	WHITE			CHAMOIS (LOGANO GRAIN)		JADE	RED	BLUE					
	Chamois	Tangerine	Red	Blue	Black	Chamois	Black	Jade	Red	Blue	Black	Red	Blue
EXTERIOR BODY COLORS													
1G	Silver Metallic										*	*	
2R	Bright Red		*	*							*	*	
3G	Dark Blue Metallic		*	*							*	*	
3U	Light Blue		*	*							*	*	
34	Medium Blue		*	*							*	*	
46	Dark Jade Metallic	*					*	*					
5M	Med. Chestnut Met.	*		*	*		*	*					
5Q	Dark Brown Metallic	*		*	*		*	*					
6E	Bright Yellow			*	*		*	*					
7W	Medium Jade	*		*	*		*	*					
8W*	Chamois Glow	*		*	*		*	*					
83	Light Chamois	*		*	*		*	*					
85	Tangerine		*	*	*		*	*					
9D	Polar White	*	*	*	*	*	*	*	*	*	*	*	*

*RPO

VINYL ROOF CODES	
Blue—B	Jade—R
Red—D	Chamois—U
White—W	

PINTO PONY — MAJOR STANDARD FEATURES



MODEL

2-DOOR PONY

EXTERIOR

- Bright aluminum bumpers, front and rear
- "Soft" front end treatment on front fenders highlighting the headlamps
- Argent painted one-piece grille
- Bright moldings on windshield and backlite
- Bright metal hub caps
- Pony emblem on front fenders

INTERIOR

- High back bucket seats in all-vinyl or cloth and vinyl seat trim
- Color-keyed, 10-oz. cut-pile carpeting
- Padded all-vinyl, color-keyed door trim panels
- Bright aluminum door scuff panels
- Mini-console mounted under instrument panel
- Black instrument panel with instrument cluster located in two round pods
- Black steering wheel and column
- Color-keyed vinyl headlining



FUNCTIONAL

- 2.3 Litre 2V 4-cylinder OHC engine
- Dura-Spark solid-state ignition
- Fully synchronized, floor-mounted 4-speed transmission
- Manual front disc brakes
- Rack-and-pinion steering
- Staggered shocks and multiple leaf spring rear suspension
- 13.0 gallon capacity fuel tank
- Bias ply tires
- 3-speed heater/defroster

See page 9 of this section for a complete list of standard equipment

PINTO SEDAN — MAJOR STANDARD FEATURES



MODEL

2-DOOR SEDAN

EXTERIOR

The Pinto Sedan shares many of its exterior features with the Pinto Pony. Some common features include:

- Bright aluminum bumpers, front and rear
- "Soft" front end treatment on front fenders highlighting the headlamps
- Argent painted one-piece grille
- Bright moldings on windshield and backlite
- Bright metal hub caps

Additional features include:

- Bright drip and belt moldings

INTERIOR

The Pinto Sedan shares almost all interior features with the Pinto Pony. These features include:

- High back bucket seats in all-vinyl or cloth and vinyl seat trim
- Color-keyed, 10-oz. cut-pile carpeting
- Padded all-vinyl, color-keyed door trim panels
- Bright aluminum door scuff panels
- Mini-console mounted under instrument panel
- Color-keyed vinyl headlining

Additional features include:

- Color-keyed instrument panel
- Color-keyed steering wheel and column



FUNCTIONAL

Pinto Sedan shares all functional features with the Pinto Pony. These features are:

- 2.3 Litre 2V 4-cylinder OHC engine
- Dura-Spark solid-state ignition
- Fully synchronized, floor-mounted 4-speed transmission
- Manual front disc brakes
- Rack-and-pinion steering
- Staggered shocks and multiple leaf spring rear suspension
- 13.0 gallon capacity fuel tank
- Bias ply tires
- 3-speed heater/defroster

See page 9 of this section for a complete list of standard equipment.

PINTO RUNABOUT — MAJOR STANDARD FEATURES



MODEL

3-DOOR RUNABOUT

EXTERIOR

The Pinto Runabout shares many of its exterior features with the 2-Door Sedan. Some common features include:

- Bright Aluminum bumpers, front and rear
- "Soft" end treatment on front fenders
- Argent painted one-piece grille
- Large 2-pod taillamps

Additional features include:

- 3rd door providing access to cargo area
- Large rear glass area

INTERIOR

The Pinto Runabout shares almost all interior features with the 2-Door Sedan. These features include:

- High back bucket seats in all-vinyl or cloth and vinyl trim
- Color-keyed, 10-oz. cut-pile carpeting
- Padded all-vinyl, color-keyed door trim panels
- Bright aluminum front door scuff plates
- Mini-console mounted under instrument panel
- Color-keyed steering wheel

Additional features include:

- Fold-down rear seat
- 29.0 cu. ft. cargo volume index with rear seat folded down
- Black rubber mat on cargo area floor and back of fold-down seat



FUNCTIONAL

The Pinto Runabout shares all functional features with the 2-Door Sedan. These features are:

- 2.3 Litre 2V 4-cylinder OHC engine
- Dura-Spark solid-state ignition
- Fully synchronized, floor-mounted 4-speed transmission
- Manual front disc brakes
- Rack-and-pinion steering
- Staggered shocks and multiple leaf spring rear suspension
- 13.0 gallon capacity fuel tank

An additional feature is:

- Gas cylinder hold-open design for liftgate

See page 9 of this section for a complete list of standard equipment.

PINTO STATION WAGON — MAJOR STANDARD FEATURES



MODEL

2-DOOR STATION WAGON

EXTERIOR

The Pinto Station Wagon shares many of its exterior features with the 2-Door Sedan. Some common features include:

- Bright aluminum bumpers, front and rear
- "Soft" end treatment on front fenders
- Argent painted one-piece grille

Additional features include:

- Flipper rear side windows
- Bright side and liftgate window moldings

INTERIOR

The Pinto Station Wagon shares almost all interior features with the 2-Door Sedan. These features include:

- High back bucket seats in all-vinyl or cloth and vinyl trim
- Color-keyed, cut-pile carpeting
- Padded all-vinyl, color-keyed door trim panels
- Bright aluminum front door scuff plates
- Mini-console mounted under instrument panel
- Color-keyed steering wheel

Additional features include:

- Fold-down rear seat
- Black rubber mat in cargo area and on fold-down rear seat-back
- 57.2 cubic foot cargo volume index with rear seat folded down

FUNCTIONAL

The Pinto Station Wagon shares these features with the Pinto Sedan:

- 2.3 Litre 2V 4-cylinder OHC engine
- Fully synchronized, floor-mounted 4-speed manual transmission
- Dura-Spark solid-state ignition
- Staggered shocks and multiple leaf spring rear suspension



Additional features include:

- Easy open tailgate with counter-balanced supports
- 14 gallon fuel tank
- Liftgate "open" warning light

See page 9 of this section for a complete list of standard equipment.

- *Front stabilizer bar.*

PINTO — STANDARD EQUIPMENT SUMMARY

In addition to the standard features listed, Pinto includes, as standard equipment, the Ford Lifeguard Design Safety Features listed in the General Information Section.

EXTERIOR	2-Door Pony	2-Door Sedan	3-Door Runabout	Station Wagon
BUMPERS: Bright aluminum, front and rear	X	X	X	X
GRILLE: One-piece argent plastic	X	X	X	X
HOOD: Single-action with inside hood release	X	X	X	X
HUB CAPS: Bright metal	X	X	X	X
LIGHTS: Single headlamps, soft plastic color-keyed bezels	X	X	X	X
Front parking turn signal beside grille	X	X	X	X
Front side marker, in front fender	X	X	X	X
Rear side marker, in rear quarter panel	X	X	X	X
Tail lamps, two horizontal	X	X	X	—
Tail lamps, two vertical	—	—	—	X
LIFTGATE: Lift-up with gas cylinder hold-open design	—	—	X	—
Two-stage with counter-balanced supports	—	—	—	X
MIRROR: Bright outside left-hand	X	X	X	X
MOLDINGS: Bright windshield, backlite/liftgate	X	X	X	X
Bright drip and belt	—	X	X	X
Bright hinges on liftgate	—	—	X	—
Bright side window	—	—	—	X
ORNAMENTATION: Bright FORD letters on hood	X	X	X	X
Bright FORD letters on decklid/liftgate	X	X	X	X
Pinto script on decklid/liftgate/tailgate	X	X	X	X
Soft front end fender caps	X	X	X	X
Pony decal on front fenders	X	—	—	—
PAINT: Acrylic enamel finish	X	X	X	X
WINDOW: Flipper rear side	—	—	—	X
Ventless side glass	X	X	X	X

INTERIOR

ARMRESTS: Front door, integral door pull handle	X	X	X	X
Rear, molded in quarter trim panels	X	X	X	X
ASHTRAY: Front, instrument panel	X	X	X	X
CARGO FLOOR MAT: Cargo area and back of rear fold-down seat	—	—	X	X
CARGO VOLUME: 29.0 cu. ft.	—	—	—	—
67 cu. ft.	—	—	—	—
CARPET: Color-keyed cut-pile (passenger compartment)	X	X	X	X
COAT HOOKS: Two	X	X	X	X
DOOR CHECK: "Hold-Open"	X	X	X	X
DOOR SCUFF PLATES: Bright aluminum	X	X	X	X
DOOR TRIM: All vinyl, color-keyed, door pull handle integral with armrest	X	X	X	X
GLOVE BOX: Push button	X	X	X	X
HEAD RESTRAINTS: Front seats	X	X	X	X
HEADLINING: Color-keyed vinyl	X	X	X	X
INSTRUMENT PANEL: Color-keyed with energy-absorbing crash pad	—	X	X	X
Black with energy-absorbing crash pad	X	—	—	—
Instruments in 2 recessed pods with printed circuits	X	X	X	X
LIGHTS: Courtesy dome driver front door switch	X	X	X	X
Emergency flasher — column-mounted switch	X	X	X	X
MINI-CONSOLE: Mounted under instrument panel	X	X	X	X
MIRROR: Inside windshield mounted	X	X	X	X
PEDALS: Suspended accelerator, clutch and brake	X	X	X	X
SEATS: High back bucket, self-locking, folding front seat-backs	X	X	X	X
SEAT, FOLD-DOWN: Rubber mat on seat-back	—	—	X	X
SEAT BELTS: Front continuous loop, retractor in rear quarter panel	—	—	—	—
rotating boot on front sill	X	X	X	X
Rear, lap belts with retractors	X	X	X	X
SEAT TRIM: Cloth and vinyl or all-vinyl	X	X	X	X
STEERING WHEEL: Color-keyed, deep dish	—	X	X	X
Black, deep dish	X	—	—	—
SUN VISORS: Dual, padded, color-keyed with center retention clip	X	X	X	X

FUNCTIONAL

ALTERNATOR: 40 ampere	X	X	X	X
BATTERY: 45 ampere-hour (36 amp -hr in California)	X	X	X	X
BRAKES: Manual front disc, rear drum	X	X	X	X
ENGINE: 2.3 Litre 4-cylinder OHC	X	X	X	X
FUEL TANK: 13 gallon capacity	X	X	X	—
14 gallon capacity	—	—	—	—
HEATER/DEFROSTER: Blend-air type, 3-speed blower	X	X	X	X
HOOD RELEASE, INSIDE:	X	X	X	X
KEYS: Reversible design	X	X	X	X
LIFTGATE: Lift-up with gas cylinder hold-open design	—	—	X	—
Two-stage design with counter-balanced supports	—	—	—	X
LIFTGATE WARNING LIGHT: Signals if liftgate is ajar	—	—	—	X
PARKING BRAKES: Tunnel-mounted with warning light	X	X	X	X
SOLID-STATE IGNITION: Dura-Spark	X	X	X	X
STEERING: Manual rack-and-pinion	X	X	X	X
SUSPENSION: Front, coil spring	X	X	X	X
Rear, staggered shocks, multiple leaf springs	X	X	X	X
TIRES: Bias ply*	X	X	X	X
TRANSMISSION: 4-speed manual, fully synchronized	X	X	X	X
VENTILATION: DirectAir, high and low level	X	X	X	X
WINDSHIELD WIPERS: 2-speed electric with washers	X	X	X	X
Front, dual wiper, with standard application for the station wagon	X	X	X	X

* Steel-belted radial ply in California

PINTO — SELECTED OPTION DESCRIPTIONS

Pinto offers a wide selection of factory-installed options, some of which are described here in detail. A complete optional equipment summary for Pinto models is listed on page 14 of this section.

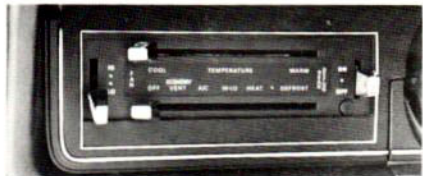

AIR CONDITIONING

Pinto's air conditioning system incorporates a condenser, combination expansion valve, suction throttling valve, and evaporator designed to provide a fast cool-down rate for passenger comfort. When the air conditioner is in operation, the suction throttling valve allows the compressor to run continuously in the A/C mode and, therefore, the evaporator which cools the incoming air provides consistently low temperatures.

Four registers on the instrument panel are positioned to ensure more complete circulation. The top control lever selects the desired air temperature, and the bottom control lever can be placed in six positions: OFF, ECONOMY/VENT, A/C, HI-LO, HEAT and DEFROST.

A separate fan switch is used to select one of four fan speeds. The A/C position cools and recirculates the air within the car, providing maximum cooling. The ECONOMY/VENT position draws a supply of fresh air in from the cowl intake and is the position most used after initially cooling the car with A/C. In this position, the air compressor does not run and does not drain power from the engine for cooling. Therefore, use of the ECONOMY/VENT position can result in improved fuel economy over use of the A/C position. Air flow is directed into the passenger compartment through the adjustable air registers. Adjustable louvers in each register control the flow of air and may be closed to shut off the flow of air.



SUNROOF

A manually operated sunroof is available on Pinto 2- and 3-door models, with or without the optional vinyl roof. This option provides the open-air advantages of a convertible and the styling and security of a hardtop. With the turn of a latch handle, the roof slides back out of sight above the headliner. When closed, the sunroof matches the roofline and seals tightly in position, keeping weather conditions and noise outside. This option is not available on station wagons.



FLIP-UP OPEN AIR ROOF

This convenient option is available on 2- and 3-door Pinto models, with or without a vinyl roof. The roof is made of tinted glass and includes a privacy shade. The panel can function as a moonroof, be flipped open for added circulation or completely removed.

The roof flips open very easily by means of a toggle latch (similar to flipper windows). When opened, the latch is pushed up to hold the rear of the roof in position. The roof can also be completely removed for the open-air feeling of a convertible. When removed, the glass panel and sun shade can be stored in the durable vinyl storage bag provided for extra protection against dirt and scratching.

CONVENIENCE/LIGHT GROUP

This option is designed for the convenience of both driver and passenger. Included in the option group are a cigar lighter, day/night mirror, passenger visor-vanity mirror and interval windshield wipers. The interval wipers reduce smearing and drying in periods of light rain, mist or car spray. They can be adjusted to wipe at intervals of from 2 to 15 seconds.



The Convenience/Light Group also includes pop-open type rear quarter windows that are held in an open/closed position by a toggle latch. This design, available on the 2-door Sedan and Runabout, provides excellent flow-through ventilation. Also included are bright door and window frames and center pillar cap.

The option further includes: a locking glove box, under hood light, cargo area light (2-door sedan and station wagon only), 3rd door courtesy light switch (Runabout), glove and ashtray light, a "lights-on" warning buzzer, passenger side courtesy door light switch and a map light. The map light is not available with the optional sunroof or flip-up open air roof.

PINTO — SELECTED OPTION DESCRIPTIONS



SPORTS RALLYE PACKAGE

This functional option package is designed for the performance-minded and is available on all Pinto models. Included is a tachometer, ammeter gauge and engine temperature gauge. Suspension components, including stiffer springs and a front stabilizer bar provide a firm, sporty ride. Rounding out the option group is a sports steering wheel.

A special axle and gear ratio is included with the 2.3 litre engine and 4-speed manual transmission combination.

4-WAY ADJUSTABLE BUCKET SEAT (DRIVER ONLY)

This option allows 4-way manual adjustment for the driver's seat. By moving one of the adjustment levers located under the seat, the driver can manually adjust the seat both back-and-forth and up-and-down.

This adjustment feature can help the driver find the most comfortable driving position and provide added driving comfort, especially on long trips.

ELECTRIC REAR WINDOW DEFROSTER

Optional on all Pintos, the heated backlite quickly defogs the glass and melts ice and snow. The heating unit consists of a silver-filled ceramic, high-resistance printed electrical circuit, silk-screened onto the inside of the backlite. While visible as a series of 1/32-inch wide, horizontal lines across the backlite, the unit does not interfere with the driver's rear vision due to the wide spacing between the lines.

The switch for operating the defroster is located under the instrument panel. A reminder light indicates when the unit is "ON." Tinted backlite glass is included with this option.

CARGO AREA COVER

Available only on the 3-Door Runabout, this new cargo area cover can provide extra security by keeping luggage and other valuables out of sight. The cover is easily attached to both sides of the rear quarter panels. When not in use, the cargo cover can be removed and stored in the cargo area until needed.



▲ ACCENT TAPE STRIPE

This new option is available on 2-door and Runabout models. Included is a wide tape stripe that extends along the upper fenders, doors, quarter panels and then extends over the roof to highlight the backlite (2-doors) or third door (Runabout). The Accent Tape Stripe is not available with two-tone paint. Rallye Appearance Package or vinyl roof. When ordered in combination with the Exterior Decor or Protection Groups, narrow black bodyside moldings replace the wide color-keyed bodyside moldings.

WHEEL COVERS

Bright, stainless steel wheel covers are optional on all Pinto models. They are included with the Squire Option, the Exterior Decor Group, and California emission equipment.



STYLED STEEL WHEELS WITH TRIM RINGS

These wheels with bright trim rings add a customized look to the Pinto. They are available on all models. Four wheels are included in this option.



FORGED ALUMINUM WHEELS

These optional wheels are available on all Pintos. The important finish dimensions are machined, resulting in a more accurate wheel designed to run truer. Four wheels are included in this option.



▲ WHITE PAINTED FORGED ALUMINUM WHEELS

These new wheels are of the same design as the bright forged aluminum wheels but feature a white finish and a red paint stripe. Four wheels are included.

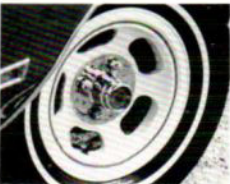

WIRE WHEEL COVERS

These classic wheel covers are available with all Pinto models.



PINTO — SELECTED OPTION DESCRIPTIONS



EXTERIOR DECOR GROUP

This option group is available with all Pinto models, except the Pony. When ordered on the 2-Door Sedan and Runabout, the option includes full wheel covers, wide wheel lip moldings, bright window frames, B pillar cap, rocker panel moldings and wide color-keyed vinyl insert bodyside moldings. When ordered with the station wagon, the option includes full wheel covers, wide wheel lip moldings, rocker panel moldings and narrow black vinyl insert bodyside moldings.

PROTECTION GROUP

Available on all Pinto models, this practical option includes front and rear bumper guards with rubber inserts, horizontal bumper rub strips, vinyl insert bodyside moldings, door edge guards, bright license plate frames, (rear only unless front license plate bracket is ordered) and front color-keyed floor mats with carpet inserts.



INTERIOR DECOR GROUP

This luxury option, available with all Pinto models, except the Pony, includes low-back bucket seats that offer a choice of cloth or vinyl inserts, 10-oz. color-keyed cut-pile carpeting in the passenger compartment (12-oz. cut-pile carpet on the load floor for the Runabout and Station Wagon), deluxe door trim panels, custom 2-spoke steering wheel, woodtone applique on the instrument panel and a cigar lighter. Other features include a black painted parking brake lever with a woodtone handle, woodtone shift knob or automatic transmission woodtone shift bezel, color-keyed parking brake boot, passenger door courtesy light switch, a rear seat ashtray, color-keyed deluxe seat and shoulder belts and a deluxe sound package. A luggage compartment mat is also offered when this option is ordered on the 2-Door Sedan model.

▲ AM RADIO WITH DIGITAL CLOCK

This new entertainment option features a quartz crystal digital clock that provides a readout of either time or broadcast frequency at the touch of a button. When the car is started, the digital readout of the time will automatically come on.

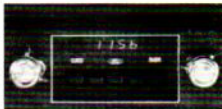

To obtain the radio frequency or time, the operator merely pushes the button for the function desired. Other audio options include AM, AM-FM Monaural, AM with Stereo Tape Player and AM-FM Stereo Radios.



CRUISING WAGON

The popular Cruising Wagon option includes:

EXTERIOR

- Steel side panels from "B" to "D" pillars
- Porthole windows
- Large graphics on the upper quarter panel
- Lower bodyside dual color tape treatment
- Dual color-keyed remote-control outside mirrors
- Styled steel wheels with bright trim rings
- Front spoiler

Note: Power brakes are required at extra cost.

INTERIOR

- Sports Rallye Package consisting of: tachometer, ammeter gauge, temperature gauge, sports steering wheel and suspension revisions (stiffer springs and front stabilizer bar) for a firm, sporty ride and a special axle and gear ratio for the 2.3 litre engine with 4-speed manual transmission
- Carpeting on the load floor and the upper quarter panels

OPTIONAL CRUISING WAGON TWO-TONE PAINT/TAPE TREATMENT

An optional Silver Paint and Tape Treatment as pictured above, is available with the Cruising Wagon. Black accents are used on the lower bodyside, door frames, B pillar moldings, and forward of the upper quarter panel. Dual sport mirrors are also black. A three-color tape stripe accents the hood, bodyside, and quarter panel and tailgate. Interior trim is available in a choice of two colors, red or black.

Also included with this paint and tape treatment option is a luggage rack.

▲ New for 1978

PINTO — SELECTED OPTION DESCRIPTIONS



RALLYE APPEARANCE PACKAGE

This sporty option is available on both 2-door models and the 3-door Runabout.

Included are:

- **Styled steel wheels with bright trim rings**
- **Black accent moldings for windshield, backlite, side windows, door belts and drip rails**
- **Black windshield wiper arms**
- **Dual sport mirrors**

- **Dual gold accent bodyside and hood stripes**
- **Sporty black front spoiler**
- **All-glass third door on the Runabout**

The Rallye Appearance Package is available in white, dark blue, dark brown and dark jade metallic exterior colors.

NOTE: Power front disc brakes are required at extra cost.



SQUIRE OPTION

The popular Squire option is available on the Pinto Station Wagon. This option includes:

EXTERIOR

- **Simulated woodgrain on the bodyside and liftgate**
- **"Squire" script on lower right corner of tailgate**
- **Full wheel covers**

INTERIOR

- **Color-keyed carpet on load floor and back of fold-down rear seat**
- **Low back bucket seats**
- **Deluxe seat trim with Alpine cloth or Ruffino vinyl inserts**
- **Deluxe door trim panels**
- **Custom steering wheel**
- **Woodtone applique on the instrument panel**
- **Woodtone shift knob or woodtone applique for the automatic transmission PRNDL bezel**
- **Black painted parking brake lever with woodtone shift knob**
- **Color-keyed parking brake boot**

- **Color-keyed deluxe seat and shoulder belts**
- **Cigar lighter**
- **Passenger door courtesy light switch**
- **Rear seat ashtray**

FUNCTIONAL

- **Deluxe sound package**



PINTO — OPTIONAL EQUIPMENT SUMMARY

REGULAR PRODUCTION OPTIONS	2-Door Pony	2-Door Sedan	3-Door Runabout	Station Wagon
ACCENT TAPE STRIPE — includes wide tape stripe that extends along upper fenders, doors and quarters and surrounds the opening of the third door. Narrow black bodyside molding replaces the wide color-keyed bodyside molding when Exterior Decor Group or Protection Group is ordered. Not available with Rallye Appearance Package, two-tone paint/tape treatment, or half-vinyl roof.	X	X	X	—
AIR CONDITIONER — SELECTAIRE — not available on Pony model without California emission equipment. Power steering and tinted glass — complete — recommended.	—*	X	X	X
AXLE, OPTIONAL RATIO — standard with Sports Rallye Package, high altitude emission equipment, on sedan and Runabout models with 2.3 litre engine and Cruise-O-Matic transmission, and on station wagon models with 2.3 litre engine. Available only on sedan and Runabout models with 2.3 litre engine and four-speed manual transmission. Not available on Pony model without California emission equipment.	—*	X	X	X
BRACKET, FRONT LICENSE PLATE — required in states issuing front license plates	X	X	X	X
BRAKES, POWER FRONT DISC — not available on Pony model without California emission equipment. Required at extra cost on station wagon models with 2.3 litre engine, and on models with Rallye Appearance Package or front spoiler.	—*	X	X	X
BUMPER GROUP, DELUXE — includes front and rear rubber bumper guards and horizontal rub strips on front and rear bumpers. Standard with Protection Group.	X	X	X	X
CARGO AREA COVER	—	—	X	—
CARPET, LOAD FLOOR — standard with Interior Decor Group. Cruising Wagon Option, station wagon model with Squire Option, or on Runabout or station wagon models with California emission equipment.	—	—	X	X
CONVENIENCE LIGHT GROUP — includes interval windshield wipers, cigar lighter (except station wagon model with Squire Option, or models with Interior Decor Group), day/night mirror, visor vanity mirror, under hood glove box, map, ash tray lights, cargo area light (sedan and station wagon models only), third door courtesy light switch (Runabout model), headlights "on" warning buzzer, passenger side door courtesy light switch (except station wagon model with Squire Option, or models with interior decor group), flipper rear quarter windows with bright window frames (standard on station wagon model), and locking glove box. Map light deleted when ordered with manually operated sunroof or flip-up open air roof.	X	X	X	X
CRUISING WAGON OPTION — see page 12 for a description of option contents. Requires power front disc brakes at extra cost. Not available with full wheel covers, wire wheel covers, Exterior Decor Group, Accent Group, or left-hand sport mirror.	—	—	—	X
CRUISING WAGON SPECIAL PAINT/TAPE TREATMENT — replaces standard bodyside tape stripe graphics and includes all-around color paint/tape treatment, side tape stripe and roof luggage rack (less air deflector). Available only with Cruising Wagon Option and silver metallic paint. Not available with black narrow vinyl insert bodyside moldings.	—	—	—	X
DECOR GROUP, EXTERIOR — see page 12 for a description of option contents. Not available on station wagon model with Squire Option, or with Cruising Wagon Option, Accent Group, or Rallye Appearance Package.	—	X	X	X
DECOR GROUP, INTERIOR — see page 12 for a description of option contents. Not available on station wagon model with Squire Option.	—	X	X	X
DEFROSTER, ELECTRIC REAR WINDOW — includes tinted backlite glass. Standard with California emission equipment. Required on sedan models in state of New York.	X	X	X	X
ENGINE, 2.8 LITRE 2V 6-CYLINDER (VARIABLE VENTURI CARBURETOR ON MODELS WITH CALIFORNIA EMISSION EQUIPMENT) — includes heavy-duty battery. Requires Cruise-O-Matic transmission at extra cost. Also, power front disc brakes required at extra cost on station wagon model. Not available with high altitude emission equipment — required for models operated primarily in EPA designated high altitude areas. Includes optional ratio axle. Not available with 2.8 litre 2V engine or California emission equipment.	X	X	X	X
ALL-GLASS THIRD DOOR — standard with Rallye Appearance Package on Runabout model.	—	—	X	—
LUGGAGE RACK, DELUXE — standard with Cruising Wagon special paint/tape treatment.	—	—	—	X
MIRRORS, DUAL SPORT — includes color-keyed remote control mirrors. Standard with Cruising Wagon Option and Rallye Appearance Package. Not available with special paint (DSO or PTO).	X	X	X	X
MOLDINGS, BLACK NARROW VINYL INSERT BODYSIDE — brown insert on station wagon model with Squire Option. Not available with Exterior Decor Group, Protection Group, Cruising Wagon special paint/tape treatment, or Rallye Appearance Package.	X	X	X	X
MOLDINGS, ROCKER PANEL — standard with Exterior Decor Group.	X	X	X	X
PAINT, METALLIC GLOW — not available with two-tone paint/tape treatment.	X	X	X	X
PAINT/TAPE TREATMENT, TWO-TONE — includes lower bodyside contrasting color paint/tape. Not available with half-vinyl roof, accent group, metallic glow paint, accent tape stripe, or Rallye Appearance Package. When ordered with Exterior Decor Group or Protection Group, narrow black bodyside moldings replace wide color-keyed moldings. Wide wheel lip moldings and rocker panel moldings deleted with Exterior Decor Group.	X	X	X	—
PROTECTION GROUP — includes deluxe bumper group, vinyl insert bodyside moldings (wide color-keyed on Pony, sedan and Runabout models; narrow on station wagon models), and on sedan and Runabout models with two-tone paint/tape treatment, bright door edge guards, front floor mats, and license plate frames (rear only when front license plate bracket is not ordered). Vinyl insert bodyside moldings deleted on models ordered with Cruising Wagon special paint/tape treatment. NA with Rallye Appearance Package.	X	X	X	X
RADIO, AM	X	X	X	X
RADIO, AM WITH STEREO TAPE PLAYER — includes dual front door-mounted speakers.	X	X	X	X
RADIO, AM/FM MONAURAL	X	X	X	X
RADIO, AM/FM STEREO — includes front door-mounted speakers.	X	X	X	X
RALLYE APPEARANCE PACKAGE — see page 13 for a description of option contents. Available only with white, dark blue metallic, dark jade metallic, or dark brown metallic exterior paint. Not available with Exterior Decor Group, wheel covers, wire wheel covers, two-tone paint/tape treatment, Accent Tape Stripe, optional bodyside moldings, Accent Group, left-hand sport mirror, vinyl roof, or Protection Group. Requires power front disc brakes at extra cost.	—	X	X	—

PINTO — OPTIONAL EQUIPMENT SUMMARY

REGULAR PRODUCTION OPTIONS

	2-Door Pony	2-Door Sedan	3-Door Runabout	Station Wagon
ROOF, FLIP-UP OPEN AIR	X	X	X	—
ROOF, HALF-VINYL — includes dual over-the-roof tape stripe. Not available with two-tone paint/tape treatment, Accent Tape Stripe, or Rallye Appearance Package	X	X	X	—
SEAT, FOUR-WAY MANUAL DRIVER'S	X	X	X	X
SPORTS RALLYE PACKAGE — includes tachometer, ammeter, temperature gauges, front stabilizer bar, sports steering wheel, and optional ratio axle. Standard with Cruising Wagon Option	—	X	X	X
SQUIRE OPTION — see page 13 for a description of option contents	—	—	—	X
STEERING, POWER — recommended with 2.8 litre engine and air conditioner. Not available on Pony model without California emission equipment	—*	X	X	X
SUNROOF, MANUALLY OPERATED	—	X	X	—
TINTED GLASS — COMPLETE — recommended with air conditioner	X	X	X	X
TIRES, WSW — bias ply	X	X	X	X
TIRES, STEEL-BELTED RADIAL PLY — BSW and WSW. BSW standard with California emission equipment	X	X	X	X
TRANSMISSION, SELECTSHIFT CRUISE-O-MATIC — required with 2.8 litre engine. Not available on Pony model without California emission equipment	—*	X	X	X
WHEEL COVERS — standard on station wagon with Squire Option, or with Exterior Decor Group or California emission equipment. Not available with Cruising Wagon Option, or Rallye Appearance Package	X	X	X	X
WHEELS, FOUR FORGED ALUMINUM — spare tire equipped with standard wheel. Not available with A70 RWL tires	X	X	X	X
WHEELS WITH TRIM RINGS, FOUR STYLED STEEL — spare tire equipped with standard wheel. Standard with Cruising Wagon Option and Rallye Appearance Package	X	X	X	X
WHEEL COVERS, WIRE — not available with Cruising Wagon Option or Rallye Appearance Package	X	X	X	X
WHEELS, FOUR WHITE PAINTED FORGED ALUMINUM — spare tire equipped with standard wheel	X	X	X	X

* Available on Pony with California emission equipment

LIMITED PRODUCTION OPTIONS

ACCENT GROUP — includes bright window frames and 'B' pillar caps on Pony, sedan and Runabout models; wide wheel lip moldings on all models. Available only for fleet. Not available on station wagon model with Squire Option, or with Exterior Decor Group, Cruising Wagon Option, Rallye Appearance Package, or two-tone paint/tape treatment	X	X	X	X
BUMPER GUARDS, FRONT AND REAR — includes rubber inserts. Standard with deluxe bumper group and Protection Group. Available only for fleet, except in required states. Required in states of California and Florida, except when Protection Group or deluxe bumper group is ordered	X	X	X	X
CIGAR LIGHTER — standard with convenience light group and Interior Decor Group. Available only for fleet	X	X	X	X
EMISSION EQUIPMENT, CALIFORNIA — required and only available in state of California. Not available with high altitude emission equipment	X	X	X	X
HEATER, ENGINE BLOCK IMMERSION	X	X	X	X
LIGHT, LUGGAGE COMPARTMENT — standard with convenience light group. Available only for fleet	X	X	—	—
MIRROR, INSIDE DAY/NIGHT — standard with convenience light group. Available only for fleet	X	X	X	X
MIRROR, LEFT-HAND SPORT — remote control color-keyed mirror. Available only for fleet. Not available with Cruising Wagon Option, Rallye Appearance Package or special paint (DSO or PTO)	X	X	X	X
TINTED GLASS — WINDSHIELD — available only for fleet	X	X	X	X

PINTO — CHASSIS FEATURES

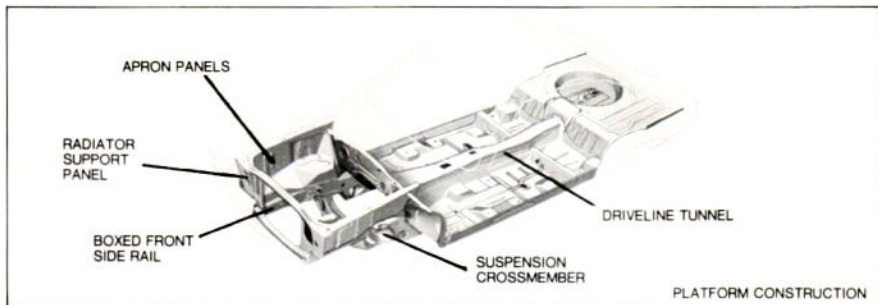

PLATFORM CONSTRUCTION

Pinto's unit body design incorporates a platform-type chassis which provides a structural base for the body as well as an enclosure for the engine. The platform structure also provides a base for underbody chassis component attachments. Features and benefits of the design:

- The boxed side rails and stiffening crossmembers are made of sheet steel and are welded to the floor pan to form a strong basic foundation for the body.
- The front and rear side rails are also welded to the floor pan. A "backbone" formed by the full-length tunnel gives the structure substantial rigidity.
- The fender apron panels in the engine compartment are welded to the front side rails at the bottom and to the dash and cowl at the rear for front-end rigidity.

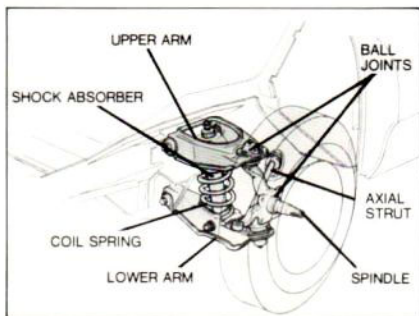

FRONT SUSPENSION

Pinto uses a short-and-long-arm type independent front suspension. Design features and benefits of Pinto's suspension include:

- Coil springs mounted on the lower arms. This design eliminates the need for high spring towers, providing more room in the engine compartment.
- Rubber-mounted struts attach to the lower control arms which allow the front wheels to recoil slightly to lessen road shock.
- Suspension geometry designed to minimize toe-in change during front wheel turning to prevent tire scuffing.

- Ball joints and tilted upper control arms combine to minimize "nose diving" that can occur upon sudden braking.
- The sedans with the optional 2.8 litre engine and the station wagon are equipped with a rubber-bushed stabilizer bar that prevents excessive leaning during cornering.

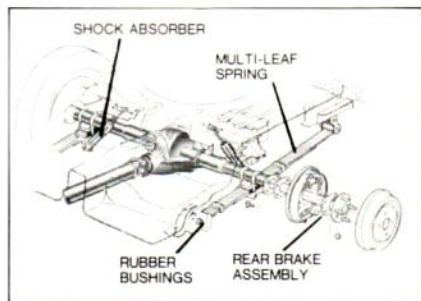

REAR SUSPENSION

Pinto's Hotchkiss-type rear suspension features thick rubber bushings at the chassis connection points. Other features and benefits include:

- Long 48.5-inch multi-leaf, semi-elliptical springs help smooth out driving and braking forces (sedans only). Rubber-insulated spring pivots and shackles help prevent noise transfer to the body.
- Staggered shock absorbers (the right mounted in front of the axle; the left behind it) counteract wheel hop and help maintain traction during acceleration.
- Rear shock absorbers are positioned at an angle to minimize side sway.

PINTO — CHASSIS FEATURES

PINTO SUSPENSION SPECIFICATIONS

FRONT

Type	Independent with Ball Joints
Springs	3.50" ID Coil
Shock Absorbers	Direct Acting, Integral Rebound Stop and Jounce Bumper
Steering Knuckle	Integral Spindle and Steering Arm
Wheel Bearings	Tapered Roller

REAR

Type	Semi-Elliptical Springs
Number of Leaves	Station Wagon — 5, Sedans — 4
Leaf Length and Width	Sedans — 48 5" x 2 5" Station Wagons — 51 5" x 2 5"
Springs Shackles	Compression
Shock Absorbers	Direct-Acting, Integral Rebound Stop
Jounce Bumper	Rubber Outrigger
Wheel Bearings	Single Row, Double-Sealed Ball

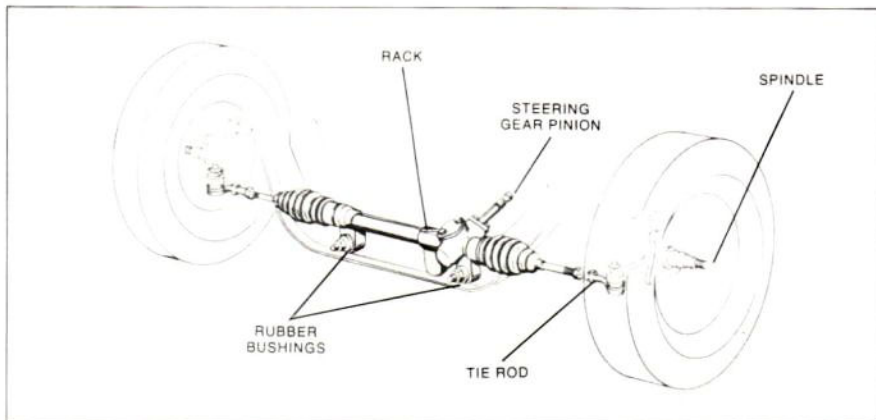

RACK-AND-PINION STEERING

Pinto's rack-and-pinion steering provides precise steering response. In this system a pinion, mounted directly to the steering shaft, engages a linear-toothed section (the rack) of the center tie rod. This is a simple, direct and low-friction system which eliminates the pitman arm, drag link and conventional gear box. Other design features include:

- A universal joint at the forward end of the steering gear shaft which permits the shaft to deflect in the event of collision and minimizes the transmittal of road vibrations to steering wheel.
- The steering rack housing is mounted on two rubber bushings to help reduce road shock.
- Tie rods are short and mounted directly to the spindle arms.

See page 20 of this section for steering specifications.

POWER RACK-AND-PINION STEERING

Pinto offers optional power rack-and-pinion steering. This type of steering system, used by many European high-performance luxury cars, combines the precise control of rack-and-pinion steering with the low effort of domestic power systems. For 1978 a new variable ratio rack-and-pinion steering gear, combined with a new improved power assist pump, has been added to the steering system. This system further reduces the effort required during parking maneuvers, provides improved road "feel" at highway speeds and reduces the power demand on the engine.

See page 21 of this section for steering specifications.

FRONT DISC/REAR DRUM BRAKES

All Pintos are equipped with manual front disc/rear drum brakes. Disc brakes are designed to resist fade, help eliminate braking pulls and dissipate heat more effectively.

Power front disc/rear drum brakes are optional on all Pinto models and are required on the station wagon when equipped with the optional 2.8 Litre V-6 engine and all models with a front spoiler.

4-SPEED MANUAL TRANSMISSION

A floor-mounted 4-speed manual transmission is standard on all Pinto models when equipped with the 2.3 Litre engine.

Design features include:

- Enclosed single rail shift mechanism for a positive "shift feel."
- Optimum spacing between gear ratios for smooth, efficient performance.
- Full synchronization for rapid upshifts and downshifts.

PINTO — BODY FEATURES



BODY CONSTRUCTION

The integral all-welded construction of the Pinto body platform provides strength with light weight. The body metal and structural members are solidly welded to the underbody to form a completely unitized construction. Some of the advantages and design features include:

- The body structure is framed on the assembly line in precision welding fixtures providing good alignment of doors, hood and decklid.
- Strong reinforcing members are used at roof pillars, roof and bodyside rails and around the windshield and rear window for added strength.
- The roof structure (unlike conventional roof designs) does not require separate windshield and rear window headers, inner roof rails or roof reinforcements.

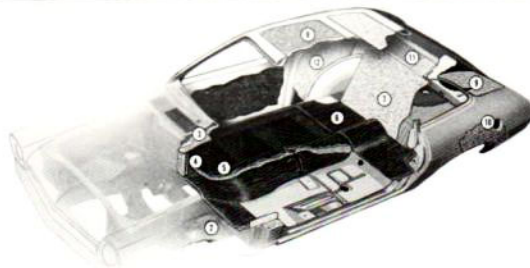

BODY INSULATION

Numerous acoustical pads, sound isolators and spray-on deadeners are used to form a sound barrier against engine and road noise.

- (1) The hood has mastic adhesive spotted between the inner and outer panel construction.
- (2) Front fenders and aprons have a sound-deadening coating sprayed on the side toward the front wheels.
- (3) The dash panel has a one inch textile pad coated with 3/4-lb. plastisol.
- (4) The inner cowl top is covered with a one-half inch textile fiber pad absorber. Cowl sides are insulated with 1/4 inch thick material of the same type.
- (5) The front floor pan and entire tunnel have a 3/4 inch thick fiber pad with 1 lb. mastic. The tunnel also has a 1/2 inch thick heat bondable mastic. Additional pieces of 1/2 inch thick fiber pads with 8-oz. plastisol and 1/4 inch thick laminated fiberglass are used for added heat protection.
- (6) The floor area under the rear seat uses a .37 inch thick, 1 lb. mastic and fiber pad.
- (7) The rear seat area has a 1/2 inch wood fiber pad absorber behind the rear seat, which forms a barrier between the luggage compartment and passengers.
- (8) The roof panel has a 1/4 inch thick textile fiber pad blanket which insulates the entire roof panel from front to rear.
- (9) The roof "C" pillars are lined with 1/4 inch textile fiber pads with poly film.
- (10) Rear wheelhousing splash areas are sprayed with a vinyl sealer.
- (11) The package tray and package tray extensions have a 1/4 inch thick wood or cotton fiber pad with black poly film.
- (12) The bodyside quarter panels and rear inner wheelhouses are lined with 1/4 inch, 56 gram fiber pads with black poly film.

PINTO — BODY FEATURES

BODY SEALING MATERIAL

The following joint sealers and special anti-squeak and sealing devices are used in the Pinto to help assure a comfortable quiet ride.

- Plastic sealing material applied to exposed spot-welded body panel seams and joints.
- Vinyl-plastic seals on the drip rails and rear deck trough. Windshields and backlites sealed with rubber weatherstrips. Special pads, grommets, seals and plug buttons guard against water, dust and drafts.
- Heat-curing sealer applied to all other panel seams and joints.
- Large diameter, tubular weatherstripping provides tight seals around all doors.

LIFTGATE WARNING LIGHT

Standard with the Pinto station wagon model is a Liftgate Open warning light. This extra safety feature senses when the tailgate is not fully closed and illuminates the warning light that is located in the instrument cluster.

VENTILATION SYSTEM

Pinto's standard DirectAir® ventilation system provides comfort for driver and passengers in city and highway driving.

Push-pull knobs located below the air outlet registers permit control of the air valves.

- With knobs all the way in — air valves are closed.
- With knobs all the way out — air is directed upward toward driver and passenger.
- With knob halfway out — air flow is divided so that three-fourths of the flow is directed toward the floor, while the remainder is directed upward toward driver and passenger.

HEATING SYSTEM

The Pinto heater/defroster system has been designed to provide optimum heating comfort.

The high-capacity hot water system features a powerful three-speed blower to provide heating comfort even in stop-and-go cold weather driving. Controls for the blower and heater are located in the center of the instrument panel within easy reach of the driver and front seat passenger. When the Sports Rallye package is ordered, the heater controls are located in the mini-console, below the instrument panel.

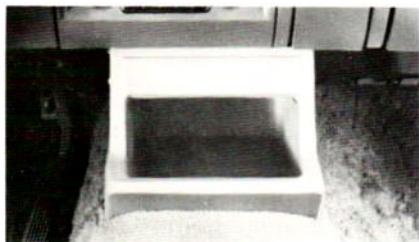

MINI-CONSOLE

Standard with all Pinto models is the handy mini-console that is located under the instrument panel. The console conveniently holds many small items and keeps them within easy reach of the driver and/or the front seat passenger.

SEAT CONSTRUCTION

Pinto seats are designed to provide firm yet comfortable body support. The sports-styled front bucket seats are constructed of formed steel. The cushions are constructed of urethane foam molded around spring and frame elements to form well-contoured, comfortable seats. The driver and passenger seats are adjustable and mounted on curved seat tracks which raise the seat for short drivers when it's moved forward and lower the seat for tall drivers when it's moved back. The folding front seat-backs self-lock into an upright position. A small knob located near the outer edge of the seat-back releases the lock for rear seat entry.



RUNABOUT REAR DOOR

The Runabout includes a lift-up rear door and a fold-down rear seat. A gas-filled cylinder hold-open design provides positive and convenient operation when the third door is open. The door opening is a generous 24.7 inches in height. With the rear seat folded down, there is a flat cargo floor space extending to the front seat-backs that measures a full 61.1 inches. The compartment is 41.2 inches across at the wheelhousings, providing plenty of cargo space.

An all-glass rear door is also available as an option on the Runabout. This door features a bright handle and bright exposed hinges.

DOOR CONSTRUCTION

Pinto doors are formed into a sturdy box unit by using a double-panel, welded construction. Bronze bushed hinges are oil-impregnated for long wear and easy opening and closing.

The lower hinges are provided with assist springs to aid in opening the doors and to retard slamming when closing. The doors incorporate a check feature to hold the doors in the full-open position.

"Bear hug" door latches provide secure closing, easy opening, rattle resistance and help to prevent door opening in the event of a collision. Weatherstripping is mechanically retained by plastic retaining pins, rather than adhesive alone, to maintain more positive door sealing against dirt and moisture. Keyless door locking and reversible keys for door and trunk locks are additional Pinto convenience features.

PINTO — BODY FEATURES

HOOD CONSTRUCTION

A "halo" inner panel reinforces the Pinto hood construction. Rubber bumpers along the front and sides of the hood provide cushioning against squeaks and rattles. All Pinto models feature an inside hood release.

An outside safety catch still must be released to raise the hood. The hood is held open by a conveniently located prop rod and can be opened a full 90° for added convenience in reaching components in the engine compartment.

WINDOW CONSTRUCTION

Side and backlite windows on all Pinto models are high-strength, impact-resistant, heat-tempered glass. The windshield is constructed of two sheets of glass which are sandwiched to a 30 mil

thick plastic sheet and heat-laminated together. This type of windshield construction provides strength and pliability which enables the windshield to take "stretch" under impact, minimizing injury-producing penetration.

LUGGAGE COMPARTMENT

The interior of the Pinto 2-door's luggage compartment is finished in painted metal, with the spare tire stored in a well in the floor. Trunk lid construction features a built-in torsion bar in each hinge to assist in raising the lid and holding it open. Compression-type, neoprene rubber weather stripping provides protection against dirt and moisture.

PINTO — GENERAL SPECIFICATIONS

BODY DIMENSIONS

All dimensions are in inches unless otherwise specified.

GENERAL

	Pony, Sedan/ Runabout	Station Wagon
Wheelbase	94.5	94.8
Tread — Front	55.0	55.0
— Rear	55.8	55.8
Height — Overall	50.6	52.0
Length — Overall	169.3	179.1
Width — Overall	69.4	69.7

FRONT SEAT ROOM

	Pony/ Sedan	Station Wagon
Head Room (Effective)	37.3	37.9
Shoulder Room	52.5	52.5
Hip Room	51.6	51.6
Maximum Leg Room to Accelerator	40.8	40.8

REAR SEAT ROOM

	Pony/ Sedan	Station Wagon
Head Room (Effective) (seat in position)	35.7/35.8	38.9
Shoulder Room	50.5/50.0	51.0
Hip Room	41.3/39.4	39.4
Minimum Effective Leg Room	30.3/29.6	29.6

LUGGAGE COMPARTMENT

	Pony/ Sedan	Station Wagon
Usable Luggage Capacity (cu. ft.)	6.3*	—
Liftover Height	28.3	20.3

* Pony & Sedan Only

** Runabout Only

*** Weight of vehicle with oil, water and a full tank of gas.

CARGO COMPARTMENT

	Pony, Sedan/ Runabout	Station Wagon
Cargo Volume (cu. ft.)	29.0**	57.2
Load Floor length (closed tailgate) 2nd seat down	61.1	69.1
Maximum rear opening width at belt	—	48.8
Rear opening height	24.7	28.0
Minimum floor width (between wheelhousings)	41.2**	42.5
Fuel Tank Capacity (gal.)	13.0	14.0

GLASS AREAS (Sq. Ft.)

	Pony/ Sedan	Run- about	Station Wagon
Windshield exposed surface area	7.34	7.34	7.34
Side glass exposed surface area	9.47	9.47	15.41
Backlite glass exposed surface area	5.23	8.04	4.05
Total glass exposed surface area	22.03	24.85	26.80

CURB WEIGHT (Lbs.)***

2-Door Pony	2426
2-Door Sedan	2426
Runabout	2472
Station Wagon	2634
Station Wagon w/ Squire Option	2690

PINTO — GENERAL SPECIFICATIONS

STEERING SPECIFICATIONS

Gear Type	Rack-and-Pinion
Overall Steering Ratio (Manual)	24.06:1
Overall Steering Ratio (Variable Power)	18.2:1 at center 14.3:1 at stops
Turning Diameter (Curb-to-Curb)	30.7 ft
Steering Wheel Diameter	15.0 in.
Steering Wheel Turns (Lock-to-Lock)	3.25

WHEEL SPECIFICATIONS

Type	Stamped Steel Disc Ventilated disc with safety-type rims
Number of Studs	4
Diameter and Rim Size Standard	13.0" x 5.0"
Optional	13" x 5.5"
Aluminum	all models
Bolt Circle (all)	4.25"

BRAKE SPECIFICATIONS

Front Disc/Rear Drum	All Models
Brake Rotor Dia. (Disc)	9.3
Outer Working Surface Dia.	9.3
Inner Working Surface Dia.	6.24
Front Swept Area*	145.5 sq. in.
Drum Diameter/Width	9" x 1-3/4"
Rear Swept Area*	98.9 sq. in.
Total Front and Rear Swept Area*	244.4 sq. in.
Lining Material	Molded Asbestos Riveted
Parking Brake — Type	Mechanical Actuation of Rear Brakes

* Swept Area is the effective working surface.

STANDARD TIRE AVAILABILITY

Model	2.3 Litre Engine	2.8 Litre Engine
2-Door Pony Sedan	A78 x 13 BSW	A78 x 13 BSW*
3-Door Runabout	A78 x 13 BSW	A78 x 13 BSW*
Station Wagon	A78 x 13 BSW	A78 x 13 BSW*

* B78 x 13 BSW, standard with air conditioning.

OPTIONAL TIRE AVAILABILITY

STANDARD TIRE	A78 (a) WSW	A70 (a) RWL	B78 BSW	B78 WSW	BR78* BSW	BR78* WSW	BR70* RWL
A78 x 13	X	X	X	X	X	X	X

(a) NA with 2.8 Litre engine with air conditioning.

* Includes front stabilizer bar.

PINTO — GENERAL SPECIFICATIONS

POWER TEAM COMBINATIONS

49 STATES					
ENGINES	TRANSMISSIONS		REAR AXLE RATIOS		
	4-Speed Manual	Cruise-O-Matic	4-Speed Manual		Cruise-O-Matic
			STD	OPT	STD
2-Door Pony/Sedan/ 3-Door Runabout 2.3 Litre (S:D) (a) 2.8 Litre (OPT)* (c)	STD NA	OPT OPT	2.73 —	3.18 (a) —	3.18 3.40
Station Wagon 2.3 Litre (STD) 2.8 Litre (OPT)	STD NA	OPT OPT (b)	3.18 —	— —	3.18 3.40
<p>* NA with Pony (a) Included in Sports Rallye Package Option (b) Requires power front disc brakes at extra cost</p> <p style="text-align: right;"><i>(c) 2.18 ratio required with 4 speed transmission in areas formerly designated high altitude.</i></p>					
<p>HIGH ALTITUDE <i>rescinded</i></p>					
<p>delete: the High Altitude Chart Note: The 2.8 Litre engine with automatic transmission (3.40 ratio) is available for all models in areas formerly designated high altitude.</p>					
CALIFORNIA					
			STD	OPT	STD
2-Door Pony/Sedan/ 3-Door Runabout 2.3 Litre (STD) 2.8 Litre (OPT)*	STD NA	OPT OPT	2.73 —	3.18 (a) —	3.18 3.40
Station Wagon 2.3 Litre (STD) 2.8 Litre (OPT)	STD NA	OPT OPT (b)	3.18 —	— —	3.18 3.40

* NA with Pony

(a) Included in Sports Rallye Package Option.

(b) Requires power front disc brakes at extra cost.