

HUDSON SUPER-SIX PARTS LIST



JUNE
1928

127 $\frac{3}{4}$ " Wheelbase
Cars Numbered 803569 and Up

118 $\frac{1}{2}$ " Wheelbase
Cars Numbered 12269 and Up

HUDSON MOTOR CAR COMPANY
DETROIT, MICHIGAN, U. S. A.

PRINTED IN U. S. A.

HUDSON SUPER-SIX PARTS LIST

June 1928

IMPORTANT

The use of genuine Hudson parts will insure the satisfactory operation of your car.

There are Hudson-Essex distributors and dealers in all principal cities and towns, who will supply genuine Hudson parts.

For your own protection, insist upon obtaining genuine Hudson parts.

Parts which have never previously been listed are designated with a † in number required per car column.

Hudson Motor Car Company
DETROIT, MICHIGAN

Warranty

The factory obligation with respect to replacement of alleged defective parts is fully covered by our warranty as follows:

"We warrant the automobiles manufactured by us to be free from defects in material and workmanship under normal use and service, our obligation under this warranty being limited to making good any parts or part thereof which shall, within ninety (90) days after delivery of such automobile to the original purchaser, be returned to us with transportation charges prepaid, and which our examination shall disclose to our satisfaction to have been thus defective.

"This warranty is expressly in lieu of all other warranties expressed or implied, and of all other obligations or liabilities on our part, and we neither assume nor authorize any other person to assume for us any other liability in connection with the sale of our automobiles.

"This warranty shall not apply to any Hudson automobile which shall have been repaired or altered outside of our factory in any way so as, in our judgment, to affect its stability or reliability, or which has been subject to misuse, negligence or accident.

"We make no warranty whatsoever in respect to tires, rims, ignition apparatus, tops, upholstery, horns or other signaling devices, batteries, speedometers, or other trade accessories."

HUDSON MOTOR CAR COMPANY

Detroit, Michigan

The factory does not participate in any labor costs incident to the replacement of parts under the warranty. The warranty under which Hudson motor cars are sold will be interpreted by the Distributor or Dealer from whom the car was purchased. If you are touring and require service, be sure to get in touch with your nearest authorized Hudson Distributor or Dealer.

INDEX

	Page No.
Accelerator	34
Accessories	44
Axle—Front	6
Axle—Rear	8
Battery Suspension	13
Bumper	13
Brakes—Front	6
Brakes—Rear	9
Carburetor	23
Clutch	24
Controls—	14
Brake Control	33
Carburetor Mixture Control	28
Hand Control Lever (Gear Shift)	28
Hand Control Lever (Brake)	21
Heat Control	24
Pedal Control (Clutch and Brake)	32
Spark and Throttle Control	24
Shifter Control	14
Drag Link	39
Electrolock	45
Fan	14
Fenders	19
Frame	12
Gasoline Tank	13
Horn	46
Instrument Board Instruments	43
Ammeter	43
Cool Ventilator	43
Instrument Lamp	43
Oil Pressure Gauge	43
Speedometer	44
Lamps	41
Mats	45
Motor	14
Adjusting Eccentric and Water Pump Group	22
Cams	17
Camshaft	19
Camshaft Bearings	18
Connecting Rod	21
Crankcase	16
Crankshaft	17
Crankshaft Bearings	18
Cylinder	14
Cylinder Head	15
Distributor Drive Shaft Group	22
Exhaust Manifold	19
Flywheel	18
Generator Coupling	19
Intake Manifold	19
Oil Pump	23
Oil Reservoir	17
Piston	21
Rocker Arm	20
Sprockets	18
Timing Sprockets and Chain	18
Valves	20
Vibration Damper	18
Muffler and Exhaust Pipe	24
Radiator	13
Rim	10
Remble Seal Steps	40
Running Board	10
Splash Guard	40
Shield—Rear—Over Gas Tank	40
Springs—Front	10
Springs—Rear	11
Stabilizer	38
Steering Gear	35
Tire Carrier	40
Tools	43
Transmission	26
Trunk Rack	46
Universal Joints and Propeller Shaft	35
Vacuum Tank Connections and Gasoline Pipes	35
Wheel—Front	9
Wheel—Rear	10
Wiring	44
R. H. Drive Parts	46



FRONT AXLE

Illus. No.	Part No.	Description	Specifications	No. Req.
		FRONT AXLE ASSEMBLY		
1	CX 28940	Front axle center		1
2	BX 29253	SPINDLE AND DUST SHIELD ASSEMBLY—R. H.		1
3	BX 29254	SPINDLE AND DUST SHIELD ASSEMBLY—L. H.		1
4	BX 21005	Spindle nut	$\frac{1}{2}$ "-16 special	2
5	BX 27438	Spindle nut washer		2
6	BX 28962	Front brake dust shield—R. H.		1
7	BX 28964	Front brake dust shield—L. H.		1
8	BX 28965	Front brake dust shield cut-out cover		2
9	BX 29388	Spindle grease deflector		2
10	BX 14497	Spindle dust washer		2
11	BX 22232	Spindle dust washer retainer—outer		2
12	BX 29587	Spindle dust washer retainer—inner		2
13	BX 70101	Spindle oil plug		2
14	BM 18243	Spindle oil plug gasket		2
15	BX 18241	Spindle set screw nut	$\frac{1}{2}$ "-16x $\frac{1}{2}$ " square head.	2
16	BM 110	Spindle set screw nut	$\frac{1}{2}$ "-16x $\frac{1}{2}$ "	2
17	BZ 21707	Spindle oil cup		2
18	BX 28966	Spindle shim—thick		4
19	BX 28961	Spindle shim—thin		4
17	BX 20110	Spindle pivot bearing	Nico—special	2
18	BX 28954	Spindle pivot pin		2
19	BX 13205	Spindle pivot pin lock		2
20	BX 28956	Spindle pivot pin bushing—lower		2
21	BX 28957	Spindle pivot pin bushing—upper		2
22	12347	Inner bearing cone and rolls	Timken 415	2
23	12346	Inner bearing cup	Timken 412A	2
24	6237	Outer bearing cone and rolls	Timken 315	2
25	5672	Outer bearing cup	Timken 312	2
26	BX 28961	Steering arm—R. H.		1
27	BX 28962	Steering arm—L. H.		1
28	BX 9220	Steering arm key		2
29	BX 21845	Steering arm ball		2
30	BM 12172	Steering arm ball nut		2
		TIE ROD ASSEMBLY		
31	CX 29309	Tie rod only		1
32	BX 29310	Ball seat		4
33	BX 29344	Shim	1/32" thick	4
33	BX 29345	Shims	1/16" thick	6
34	BX 29311	Pin		2
35	BX 29314	Spring		2
36	BX 29313	Inner cover		2
37	BX 29312	Outer cover		2
38	BZ 20310	Outer cover screw	$\frac{1}{2}$ "-21x $\frac{1}{2}$ "	2
39	BZ 3587	Outer cover screw nut	$\frac{1}{2}$ "-24	2
40	BZ 21707	Oil cup		2

FRONT WHEEL BRAKES

40	BY 29247	BRAKE SHOES ASSEMBLY (Includes three shoes)		2
41	BY 29217	Primary and auxiliary shoe spring		2
42	BY 29213	Auxiliary shoe anchor pin		2
43	BY 70115	Auxiliary shoe anchor pin nut	$\frac{1}{2}$ "-18x $\frac{1}{2}$ "	2
44	BY 29218	Secondary shoe spring		2
45	BY 29233	Secondary shoe spring anchor		2
46	BY 29214	Secondary shoe anchor pin		2
47	BY 29224	Secondary shoe anchor pin outside washer		2
48	BY 70114	Secondary shoe anchor pin nut	$\frac{1}{2}$ "-20x $\frac{1}{2}$ "	2
49	BY 70115	Secondary shoe anchor pin nut	$\frac{1}{2}$ "-18x $\frac{1}{2}$ "	2
49	BY 29212	Anchor bolt reinforcement strip		2
50	BY 29232	Articulating pin		2
51	BY 29233	Take-up cam		2
52	BY 70125	Take-up cam nut	$\frac{1}{2}$ "-20x $\frac{1}{2}$ "	2
		FRONT UNIVERSAL JOINT CONTROL ASSEMBLY		
53	BY 29226	Universal joint cover		2
54	BY 29227	Universal joint cover cap		2
55	BY 29228	Universal joint cover cap spring		2
56	BY 29229	Universal joint cover cap spring retainer		2
57	BY 29230	Universal joint cover cap spring retainer cap		2
		Front control shaft trunion assembly		
58	BY 29223	Trunion		2
59	BY 29224	Trunion pin		2
60	BY 29225	Trunion pin locking pin		2

When ordering give letter prefix with symbol number—Example: CX 28940.



HUDSON SUPER-SIX PARTS LIST

FRONT WHEEL BRAKES (Continued)

Illus. No.	Part No.	Description	Specifications	Qty. Req.
41	BY 29222	Front control shaft		2
42	BY 29229	Front cam and shaft		2
43	BY 29219	Front cam carrier bracket		2
44	BY 70113	Front cam carrier bracket bolt	5/8"-24x1 1/4"	4
45	BY 29235	Front cam carrier bracket bolt nut	3/4"-24	4
46	BY 29221	Front cam carrier bracket key		2
47	BY 29239	Front control lever		2
48	GZ 70261	Front control lever cap screw	5/16"-24x1 1/2"	2
	BR 411	Front control lever cap screw nut	5/16"-24x1 1/4"	2
49	BY 29206	STAMPED UNIVERSAL END ASSEMBLY		2
	BZ 908	Stamped universal end bolt	5/16"-18x 1/2"	4
	BZ 132	Stamped universal end bolt nut	5/16"-18x 1/2"	4
70	BY 70126	Stamped universal end plug		2

REAR AXLE

...	CY 29653	REAR AXLE ASSEMBLY	4-5/11 to 1	1
...	CY 29300	REAR AXLE ASSEMBLY	4-1/12 to 1	1
1	CY 29301	REAR AXLE HOUSING ASSEMBLY		1
2	CY 29001	Brake spider—R. H.		1
2	CY 29002	Brake spider—L. H.		1
3	CY 29245	Dust shield—R. H.		1
3	CY 29246	Dust shield—L. H.		1
4	CY 20709	Inner oil retainer		2
4	BY 20994	Inner oil retainer felt washer		2
4	BY 20710	Inner oil retainer felt washer spring		6
7	BY 19321	Housing cover		1
8	BY 19322	Housing cover gasket		1
9	BM 322	Housing cover pipe plug	1/2"	1
10	BZ 1157	Housing cover bolt	5/8"-16x 1/2"	10
...	CY 7211	Rivet	1/2"-16x 1/2"	12
...	CY 9483	Rivet	Wagon box head 1/2"x 1/2"	6
...	CY 945	Rivet	Button head 5/16"x 1"	20
...	CY 19372	DIFFERENTIAL CARRIER AND GEAR SET ASSEMBLY	4-5/11 to 1	1
...	CY 29302	DIFFERENTIAL CARRIER AND GEAR SET ASSEMBLY	4-1/12 to 1	1
11	CY 19367	DIFFERENTIAL CARRIER ASSEMBLY (Includes parts 19328, 9626, 9641, 9605 and 9999)		1
	19328	Carrier (Not sold separately)		1
	9626	Carrier cap (Not sold separately)		2
12	CY 12793	Elbow	1"	1
12	BY 12784	Filler pipe plug	1"	1
14	CM 5730	Inspection pipe plug	1/2"	1
15	BY 19322	Carrier gasket		1
15	BR 1306	Carrier bolt	3/4"-16x1 1/2"	10
16	4322	Bearing cup	Timken No. 2720	2
17	18637	Bearing cone and rolls	Timken No. 277	2
18	BY 9641	Bearing cap bolt	9/16"-12x1 1/2"	4
18	BY 9605	Bearing adjusting nut		2
20	CY 9096	Bearing adjusting nut lock		2
21	BY 20943	DIFFERENTIAL CASE ASSEMBLY		1
22	BY 20998	Differential case bolt		4
23	BY 20965	Differential case bolt lock	5/8"-16x1 1/2"	4
24	BY 9765	Differential gear		2
25	BY 9764	Differential pinion		2
26	BY 9767	Differential spider		1
27	BY 22725	Drive pinion	11 teeth	1
28	BY 22728	Drive gear	49 teeth 4-5/11 to 1	1
28	BY 25846	Drive pinion	12 teeth	1
29	BY 10971	Drive pinion shaft nut	1"-20x1 1/2"	1
	BY 26447	Drive gear (Gears and pinions should be ordered in matched sets to insure satisfactory performance)	49 teeth 4-1/12 to 1	1
30	BY 18305	Drive gear bolt	3/4"-24x1 7/16" special	10
31	BY 18144	Drive gear bolt nut	3/4"-24x21/64"	10
32	BY 23641	Drive gear bolt nut lock		4
33	BY 19549	PINION BEARING CAGE ASSEMBLY		1
34	18036	Front bearing cone and rolls	Timken No. 3196	1
35	2442	Rear bearing cup	Timken No. 3120	1
36	9696	Rear bearing cone and rolls	Timken No. 419T	1
37	12412	Rear bearing cup	Timken No. 432	1
38	BY 19144	Felt washer		1
39	BY 19145	Felt washer retainer		2
40	BY 19141	Adjusting sleeve		1

When ordering give letter prefix with symbol number—Example: CX 24960.

REAR AXLE (Continued)

Illus. No.	Part No.	Description	Specifications	No. Req.
41	BY 19142	Adjusting sleeve lock nut		1
42	BY 24470	Adjusting sleeve lock lock		1
43	BY 19143	Dust excluder		1
44	BY 19330	Bearing cage lock		1
45	BY 14031	Bearing cage clamp bolt	$\frac{1}{2}$ "-20x3 $\frac{1}{2}$ "	1
46	BZ 21707	Oil cup		1
47	BZ 9096	Companion flange		1
48	BY 9099	Companion flange key		1
49	CY 21003	DRIVE SHAFT ASSEMBLY (Includes thrust button)		2
30	BY 11470	Drive shaft thrust button		2
11	BY 9670	Drive shaft washer		2
52	BY 9681	Drive shaft key	$\frac{3}{8}$ "-14x $\frac{1}{2}$ "	2
53	BY 9628	Drive shaft key		2
54	BY 11898	Drive shaft felt washer		6
55	BY 19326	Drive shaft felt washer retainer		4
56	12486	Bearing cone and rolls	Timken 45T	2
37	12497	Bearing cup	Timken 454	2
	BZ 21707	Oil cup		2
16	BY 14573	REAR WHEEL BEARING ADJUSTING NUT ASSEMBLY		2
		(Includes bearing cup and felt washer)		2
39	BY 20994	Felt washer		2
67	BY 9468	Adjusting nut clamp bolt	$\frac{1}{2}$ "-20x3 $\frac{1}{2}$ "	2
61	BY 13954	Adjusting nut lock		2
62	BZ 72	Adjusting nut clamp nut	$\frac{1}{2}$ "-20	2
63	BY 29304	Rear wheel bearing grease deflector		2
14	BO 14126	Machine screw	No. 10-32x $\frac{1}{2}$ "	4

REAR WHEEL BRAKES

Illus. No.	Part No.	Description	Specifications	No. Req.
45	BY 29247	BRAKE SHOES ASSEMBLY (Includes three shoes)		2
		(Set for one wheel)		2
64	BY 29217	Primary and auxiliary shoe spring		2
67	BY 29213	Auxiliary shoe anchor pin		2
68	BY 79115	Auxiliary shoe anchor pin nut	$\frac{1}{2}$ "-18x $\frac{1}{2}$ "	2
69	BY 29218	Secondary shoe spring		2
70	BY 29211	Secondary shoe spring anchor		2
71	BY 29214	Secondary shoe anchor pin		2
72	BY 29234	Secondary shoe anchor pin outside washer		4
73	BY 79114	Secondary shoe anchor pin nut	$\frac{1}{2}$ "-20x $\frac{1}{2}$ "	2
75	BY 79115	Secondary shoe anchor pin nut	$\frac{1}{2}$ "-18x $\frac{1}{2}$ "	2
74	BY 29212	Anchor bolt reinforcement strip		2
75	BY 29232	Articulating pin		2
76	BY 29233	Take-up cam	$\frac{1}{2}$ "-20x $\frac{1}{2}$ "	2
77	BY 79125	Take-up cam nut	$\frac{1}{2}$ "-20x $\frac{1}{2}$ "	2
78	BY 29237	Rear camshaft		2
69	BY 29236	Rear camshaft washer		2
80	BY 29236	Rear camshaft carrier bracket		2
81	BY 79113	Rear camshaft carrier bracket bolt	$\frac{1}{2}$ "-24x $\frac{1}{2}$ "	4
82	BY 29235	Rear camshaft carrier bracket nut	$\frac{1}{2}$ "-24 special	4
83	BY 29241	Rear control lever—R.		1
83	BY 29242	Rear control lever—L.		1
84	CL 79341	Rear control lever cap screw	5-16"-24x $\frac{1}{2}$ "	2
	BR 411	Rear control lever cap screw nut	5-16"-24x $\frac{1}{2}$ "	2

FRONT WHEELS

Illus. No.	Part No.	Description	Specifications	No. Req.
		(118" Sedan, 12209 to 23077; 118" Coach, 12209 to 24311; 118" Coupe, 12209 to 24241; 127" Standard Sedan, 802569 to 812294; 127" London Sedan, 803592 to 812294; 127" Passenger Sedan, 803589 to 812294; 127" Victoria, 803589 to 812673)		
		FRONT WOOD WHEEL ASSEMBLY (Specify color)	31"x8"	2
	CW 28660	Hub assembly (Includes bearing cups)		2
	BZ 12460	Hub bolt	7-16"-14x2-11-16" special	24
	BY 561	Felt dust washer	7-16"-14x2-11-16"	24
	BX 14897	Felt dust washer		2
	BX 22232	Felt dust washer retainer—inner		2
	BX 29547	Felt dust washer retainer—outer		2
	12247	Inner bearing cone and rolls	Timken No. 415	2
	12346	Inner bearing cup	Timken No. 417A	2
	6237	Outer bearing cone and rolls	Timken No. 315	2
	5423	Outer bearing cup	Timken No. 312	2
	BZ 28675	Hub cap		2
	CW 28657	Brake drum		2
	BZ 28655	Grease shield		2
	BZ 28654	Brake inspection hole cover		2
	BZ 70099	Machine screw	Button head 5-16"-5/8 U.S.S.	2
	BZ 70099	Shake-proof lock washer		2

When ordering give letter prefix with symbol number—Example: CX 28940.

FRONT WHEELS (Continued)

(118' Sedan, 23877 and upward; 118' Coach, 24311 and upward; 118' Coupe, 24241 and upward; 127' Standard Sedan, 812286 and upward; 127' Landau Sedan, 812258 and upward; 127' 7-Passenger Sedan, 812097 and upward; 127' Victoria, 812873 and upward.)

Illus. No.	Part No.	Description	Specifications	Req.
...	CW 30629	FRONT WOOD WHEEL ASSEMBLY (Specify color)	31"x6"00"	2
...	BZ 30642	Hub assembly (Includes bearing cups)		2
...	BZ 70421	Hub bolt	5/8"x16d 1/2"	2
...	BZ 70447	Hub bolt nut	5/8"x16"	2
...	BX 14897	Felt dust washer		2
...	BX 22232	Felt dust washer retainers—outer		2
...	BX 29687	Felt dust washer retainers—inner		2
...	12347	Inner bearing cone and rolls	Timken No. 415	2
...	12346	Inner bearing cup	Timken No. 412A	2
...	42317	Outer bearing cone and rolls	Timken No. 315	2
...	3672	Outer bearing cup	Timken No. 312	2
...	BZ 29075	Hub cap		2
...	BZ 30632	Grease shield		2
...	BZ 29054	Brake inspection hole cover		2
...	BZ 70099	Machine screw	Button head 1/2"x18 U. S. S.	2
...	BZ 70098	Shake-proof lockwasher		2

REAR WHEELS

(118' Sedan, 12289 to 23877; 118' Coach, 12289 to 24311; 118' Coupe, 12289 to 24241; 127' Standard Sedan, 803569 to 812286; 127' Landau Sedan, 803569 to 812358; 127' 7-Passenger Sedan, 803569 to 812407; 127' Victoria, 803569 to 812673; 127' Victoria, 812673 and upward.)

Illus. No.	Part No.	Description	Specifications	Req.
...	CW 29051	REAR WOOD WHEEL ASSEMBLY (Specify color)	31"x6"	2
...	BZ 26544	Hub		2
...	BZ 12460	Hub bolt	7/16"x16d-11 1/2" special	24
...	BY 551	Hub bolt nut	7/16"x16 1/2"	24
...	BZ 29076	Hub cap		2
...	CW 29064	Brake drum		2
...	BZ 29055	Grease shield		2
...	BZ 29054	Brake inspection hole cover		2
...	BZ 70099	Machine screw	Button head 5/16"x18 U. S. S.	2
...	BZ 70098	Shake-proof lockwasher		2

(118' Sedan, 23877 and upward; 118' Coach, 24311 and upward; 118' Coupe, 24241 and upward; 127' Standard Sedan, 812286 and upward; 127' Landau Sedan, 812258 and upward; 127' 7-Passenger Sedan, 812097 and upward; 127' Victoria, 812673 and upward.)

Illus. No.	Part No.	Description	Specifications	Req.
...	CW 30628	REAR WOOD WHEEL ASSEMBLY (Specify color)		12
...	BZ 30630	Hub		12
...	BZ 70420	Hub bolt	5/8"x16d 1/2"	12
...	BZ 70447	Hub bolt nut	5/8"x16 1/2"	12
...	BZ 29074	Hub cap		12
...	CW 30632	Brake drum		12
...	BZ 30638	Grease shield		12
...	BZ 29054	Brake inspection hole cover		12
...	BZ 70099	Machine screw	Button head 1/2"x18 U. S. S.	12
...	BZ 70098	Shake-proof lockwasher		12

DEMOUNTABLE RIMS

Illus. No.	Part No.	Description	Specifications	Req.
...	CW 29058	Rim	31"x6"	5
...	BZ 23417	Rim lock		5
...	BZ 42590	Rim lock stud		5
...	BZ 42045	Rim safety latch		5
...	BZ 42044	Rim safety latch stud		5
...	BZ 28278	Rim clamp		24
...	BZ 28280	Rim clamp bolt		24
...	BZ 41434	Rim clamp bolt nut		24

FRONT SPRINGS

Illus. No.	Part No.	Description	Specifications	Req.
...	CZ 30437	FRONT SPRING ASSEMBLY		2
...	CZ 30460	Leaf No. 1 (Includes bushings)	47 1/2" long	2
...	CZ 30461	Leaf No. 2	36" long	2
...	CZ 30462	Leaf No. 3 (Includes small clips)	33 1/2" long	2
...	CZ 30463	Leaf No. 4	29 1/2" long	2
...	CZ 30464	Leaf No. 5	24 1/2" long	2

When ordering give letter prefix with symbol number—Example: CX 28960

FRONT SPRINGS (Continued)

Illus. No.	Part No.	Description	Specifications	No. Req.
...	CZ 30465	Leaf No. 6	20" long	2
...	CZ 30466	Leaf No. 7 (Includes large clips)	16" long	2
...	CZ 30467	Leaf No. 8	12" long	2
...	CZ 30468	Leaf No. 9	8" long	2
...	BZ 28047	Leaf clip—small		4
...	BZ 28048	Leaf clip—large		4
...	BZ 28045	Center bolt		2
...	BM 110	Center bolt nut		2
...	BZ 13224	Bushing—front end		2
...	BZ 13336	Bushing—rear end		2
...	BZ 22272	Front end bolt		2
...	BZ 16352	Front end bolt nut	9 16"×18 special	2
...	BZ 28318	Front end bolt shim		2
...	BZ 16342	Front end bolt sleeve		2
...	BZ 21707	Oil cup		2
...	BZ 24466	Shackle—plain		2
...	BZ 24452	Shackle—threaded		2
...	BZ 24464	Shackle bolt—thin head		4
...	BY 18093	Shackle bolt nut	5/8"×18 1/2"	4
...	BZ 28499	Clip		4
...	BZ 88	Clip nut	9 16"×18 1/2 16"	8
...	BZ 28297	Bumper		2
...	BZ 28296	Bumper strap		4

REAR SPRINGS

(Used on 127" Standard Sedan)

...	CZ 25821	REAR SPRING ASSEMBLY	15 leaves	2
...	CZ 25846	Leaf No. 1 (Includes bushings)		2
...	CZ 25847	Leaf No. 2	37" long	2
...	CZ 25848	Leaf No. 3 (Includes small clips)	32" long	2
...	CZ 25849	Leaf No. 4	47" long	2
...	CZ 25850	Leaf No. 5	43" long	2
...	CZ 25851	Leaf No. 6	40" long	2
...	CZ 25852	Leaf No. 7 (Includes medium clips)	36" long	2
...	CZ 25853	Leaf No. 8	33" long	2
...	CZ 25854	Leaf No. 9	30" long	2
...	CZ 25855	Leaf No. 10	26" long	2
...	CZ 25856	Leaf No. 11	23" long	2
...	CZ 25857	Leaf No. 12 (Includes large clips)	19" long	2
...	CZ 25858	Leaf No. 13	16" long	2
...	CZ 25859	Leaf No. 14	13" long	2
...	CZ 25860	Leaf No. 15	9" long	2
...	BZ 26536	Leaf clip—small		4
...	BZ 26535	Leaf clip—medium		4
...	BZ 26534	Leaf clip—large		4
...	BZ 26533	Center bolt and nut	3/4"×16 3/4"	2
...	BZ 28665	Plate		4
...	BZ 25291	Clip		4
...	BZ 88	Clip nut	9 16"×18 1/2 16"	8
...	BZ 5523	Clip lock nut	9 16"×18 1/2	8
...	BZ 28064	Clip strap		2
...	BZ 13341	Bushing—front		2
...	BZ 13224	Bushing—rear		2
...	BZ 16340	Front end bolt		2
...	BZ 16352	Front end bolt nut	9 16"×18	2
...	BZ 24072	Front end bolt shim		2
...	BZ 16343	Front end bolt sleeve		2
...	BZ 21707	Oil cup		6
...	BZ 24465	Shackle bolt		4
...	BY 18093	Shackle bolt nut	5/8"×18	4
...	BZ 24453	Shackle—plain		2
...	BZ 24454	Shackle—threaded		2
(Used on 5-Passenger Landau, 7-Passenger Sedan and Phaeton)				
...	CZ 28719	REAR SPRING ASSEMBLY	15 leaves	2
NOTE: Use component parts of spring CZ 25821				
(Used on 118" Coupe; 118" Roadster)				
...	CZ 25285	REAR SPRING ASSEMBLY		2
...	CZ 25403	Leaf No. 1		2
...	CZ 25404	Leaf No. 2		2
...	CZ 25405	Leaf No. 3		2
...	CZ 25406	Leaf No. 4		2
...	CZ 25407	Leaf No. 5		2
...	CZ 25408	Leaf No. 6		2

When ordering give letter prefix with symbol number—Example: CX 28960.

REAR SPRINGS (Continued)

(Used on 118' Coupe; 118' Roadster)

Illus. No.	Part No.	Description	Specifications	No. Req.
...	CZ 25409	Leaf No. 7		2
...	CZ 25410	Leaf No. 8		2
...	CZ 25411	Leaf No. 9		2
...	CZ 25412	Leaf No. 10		2
...	CZ 25413	Leaf No. 11		2
...	CZ 25414	Leaf No. 12		2
...	CZ 25415	Leaf No. 13		2
...	CZ 25416	Leaf No. 14		2
...	BZ 25417	Leaf clip—small		4
...	BZ 25419	Leaf clip—medium		4
...	BZ 25418	Leaf clip—large		4
...	BZ 25420	Center bolt and nut		2
...	BZ 25005	Plate		2
...	BZ 25291	Clip		4
...	BZ 58	Clip nut	9/16" x 1 1/2" 16	8
...	BZ 5523	Clip lock nut	9/16" x 1 1/2" 16	8
...	BZ 25004	Clip strap		4
...	BZ 13341	Bushing—front		2
...	BZ 13224	Bushing—rear		2
...	BZ 16340	Front end bolt		2
...	BZ 16352	Front end bolt nut	9/16" x 1 1/2"	2
...	BZ 24072	Front end bolt shim		2
...	BZ 16343	Front end bolt sleeve		2
...	BZ 21797	Oil cap		4
...	BZ 24485	Shackle bolt		4
...	BZ 18093	Shackle bolt nut	1/2" x 1 1/2"	4
...	BZ 24451	Shackle—plain		2
...	BZ 24454	Shackle—threaded		2

(Used on 118' Coach, Sedan; 127' Victoria)

...	CZ 30184	REAR SPRING ASSEMBLY		2
-----	----------	----------------------	--	---

NOTE: Use component parts of spring CZ 25295

FRAME

...	CF 30250	FRAME ASSEMBLY—127 1/2" wheelbase		1
...	CF 30252	SIDE MEMBER ASSEMBLY—R. H. (127 1/2" wheelbase)		1
...	CF 30253	SIDE MEMBER ASSEMBLY—L. H. (127 1/2" wheelbase)		1
...	CF 30251	FRAME ASSEMBLY—118" wheelbase		1
...	CF 30255	SIDE MEMBER ASSEMBLY—R. H. (118" wheelbase)		1
...	CF 30256	SIDE MEMBER ASSEMBLY—L. H. (118" wheelbase)		1
...	BZ 33258	Front end—R. H.		1
...	BZ 33259	Front end—L. H.		1
...	BZ 28650	REAR END ASSEMBLY—R. H. (Includes bushing)		1
...	BZ 28651	REAR END ASSEMBLY—L. H. (Includes bushing)		1
...	BZ 13224	Bushing		2
...	BY 326	Rivet	Button head 5/16" x 1 1/2"	12
...	BY 3197	Rivet	Button head 5/16" x 1 1/2"	2
...	BY 82	Rivet	Button head 1/2" x 1 1/2"	24
...	BY 85	Rivet	Button head 1/2" x 1 1/2"	108
...	GZ 30	Rivet	Button head 1/2" x 1 1/2"	94
...	BY 77	Rivet	Button head 1/2" x 1 1/2"	8
...	BY 994	Rivet	Button head 1/2" x 1 1/2"	6
...	GZ 20104	Rivet	Button head 1/2" x 1 1/2"	2
...	GZ 20102	Rivet	Button head 1/2" x 1 1/2"	1
...	GZ 20103	Rivet	Button head 1/2" x 1 1/2"	2
...	GZ 18293	Rivet	Wagon box head 1/2" x 1 1/2"	10
...	BZ 30265	Starting crank bracket	1/2" x 1 1/2"	1
...	BZ 18119	Bolt	1/2" x 1 1/2"	2
...	BM 110	Nut		2
...	BZ 28974	Front motor support—R. H.		1
...	BZ 28975	Front motor support—L. H.		1
...	BZ 28813	Rear motor support		2
...	BZ 28834	Body bracket—front		2
...	BZ 28835	Body bracket—Nos. 3 and 5 (127 1/2" wheelbase)		4
...	BZ 28836	Body bracket—Nos. 4 and 6 (127 1/2" wheelbase)		4
...	BZ 30103	Body bracket—Nos. 2 and 4 (118" wheelbase)		2
...	BZ 30104	Body bracket—Nos. 3 and 5 (118" wheelbase)		2
...	BZ 28837	Body bracket—rear (127 1/2" wheelbase)		4
...	BZ 30106	Rear rocker shaft stop bracket		2
...	BZ 28840	FRONT SPRING REAR BRACKET ASSEMBLY (Includes bushing)		2
...	BZ 28818	Bushing		2
...	BZ 28819	Rear spring front bracket—R. H.		1

When ordering give letter prefix with symbol number—Example: CX 28960.

FRAME (Continued)				
Illus. No.	Part No.	Description	Specifications	No. Req.
.....	BZ 28820	Rear spring front bracket—L. H.		1
.....	BZ 28835	Muffler hanger—front and rear 127 $\frac{1}{2}$ " wheelbase, front only 118 $\frac{1}{2}$ " wheelbase		2
.....	BZ 30395	Muffler rear hanger (118 $\frac{1}{2}$ " wheelbase)		1
RUNNING BOARD CHANNEL AND BRACKET ASSEMBLY				
.....	BZ 30267	Running board channel		4
.....	BZ 30268	Running board bracket—R. H.		4
.....	BZ 30269	Running board bracket—L. H.		4
.....	BZ 30270	Running board rear bracket		2
.....	BZ 42113	Idle lever support		1
.....	BY 3206	Idle lever support clevis pin	7-16x2 $\frac{1}{2}$ "	2
.....	BZ 28386	Tire carrier arm bracket—R. H.		1
.....	BZ 28387	Tire carrier arm bracket—L. H.		1
.....	BZ 29548	Tire carrier center bracket		1
.....	BZ 30630	Battery tray		1
.....	BM 18185	Battery tray bolt	$\frac{1}{2}$ "-16x2	1
.....	BM 110	Battery tray bolt nut	$\frac{1}{2}$ "-16x $\frac{1}{2}$ "	1
.....	BY 60689	Rear rubber bumper		2
.....	GM 1483	Rear rubber bumper bolt	5-16"-18x1 $\frac{1}{2}$ "	4
.....	BZ 122	Rear rubber bumper bolt nut	5-16"-18x $\frac{1}{2}$ "	4
.....	BZ 18112	Rubber ferrule		4
.....	GZ 1613	Rubber ferrule		3
.....	BZ 8437	Rubber ferrule		1
.....	BZ 20261	Rubber ferrule (Frame front end)		2
.....	BZ 28526	Steering gear opening cover		1
CROSS MEMBERS				
.....	BZ 30260	Cross tube—front small		1
.....	BZ 30261	Front cross tube pin		2
.....	BZ 30264	Plug		2
.....	CZ 30264	Cross tube—front large		1
.....	BZ 30342	Bracket—R. H. end		1
.....	BZ 30343	Bracket—L. H. end		1
.....	BZ 79236	End plug		2
.....	CZ 28891	Front center		3
.....	CZ 28892	Rear center		3
.....	CZ 28898	Rear box		1
.....	CZ 28899	Rear		1
.....	CZ 28910	Brake cross shaft		1
.....	BZ 28823	Front center cross member gusset—front right, rear left		2
.....	BZ 28824	Front center cross member gusset—front left, rear right		2
.....	BZ 28825	Rear center cross member gusset—front right		3
.....	BZ 28826	Rear center cross member gusset—front left		3
.....	BZ 28827	Rear center cross member gusset—rear right		3
.....	BZ 28828	Rear center cross member gusset—rear left		3
.....	BZ 28829	Rear cross member gusset		2
GASOLINE TANK				
GASOLINE TANK ASSEMBLY				
.....	BZ 30339	Gasoline tank cap		1
.....	BZ 23540	Gasoline tank cap gasket		1
.....	BZ 26091	Gasoline tank outlet pipe and elbow		1
.....	BZ 2348	Drain plug	$\frac{1}{2}$ " pipe	1
.....	BZ 24983	Filler neck assembly		1
GASOLINE TANK STRAP				
.....	BZ 28991	STRAP ASSEMBLY—R. H.		1
.....	BZ 28992	STRAP ASSEMBLY—L. H.		1
.....	BZ 28993	Front "T" bolt		2
.....	BZ 28994	Front "T" bolt nut		2
.....	BZ 28999	Rear bolt		2
.....	BZ 62	Rear bolt nut	$\frac{1}{2}$ "-24x21-64"	2
RADIATOR				
RADIATOR COMPLETE				
.....	A 33246	SHELL AND SHUTTERS ASSEMBLY	Specify color	1
.....	A 76346	Nuts—shell to core		2
.....	BZ 18218	Nut—shell to core screw		8
.....	BZ 28358	Shutter blade assembly	Specify color	16
.....	BZ 76340	Shutter rail assembly		2
.....	BZ 76342	Shutter operating rail assembly		1
.....	BZ 76354	Shutter bell crank		1

When ordering give letter prefix with symbol number—Example: CX 28960.

RADIATOR (Continued)

Illus. No.	Part No.	Description	Specifications	No. Req.
...	BZ 78755	Shutter bell crank bracket		1
...	BZ 28801	Finger rod bracket		1
...	BZ 28888	Lacing		2
...	BZ 18351	Lacing rivet		14
...	BZ 30335	Name plate		1
...	BZ 78495	Starting crank hole cover		1

CORE

Illus. No.	Part No.	Description	Specifications	No. Req.
...	CZ 30281	CORE TANK AND SUPPORT ASSEMBLY		1
...	BZ 70345	Screw—core to frame bracket	7/16"-14x1 1/2"	2
...	BY 551	Nut	7/16"-14x7/16"	2
...	BZ 30479	Outlet		1
...	BZ 33559	Outlet gasket		1
...	BZ 29852	Filter neck		1
...	BZ 30325	Filter cap		1
...	BZ 30328	Filter cap gasket		1
...	BZ 30288	Upper hose		1
...	BZ 30288	Lower hose		1
...	BZ 79327	Hose clamp	1-13/16"	4

RADIATOR SHUTTER CONTROL

Illus. No.	Part No.	Description	Specifications	No. Req.
...	BZ 78429	Knob		1
...	BZ 29111	Ratchet		1
...	BZ 79249	Operating rod		1
...	BM 784	Operating rod nut	1/2"-28x7/32"	1
...	CZ 5174	Operating rod clevis	1/2"-28 thread	1
...	GZ 15178	Operating rod silencer		1
...	BZ 79281	Bracket assembly		1
...	BZ 79272	Bracket spring		1

FAN

Illus. No.	Part No.	Description	Specifications	No. Req.
...	BM 30175	FAN ASSEMBLY		1
...	BM 30110	Spider and blades		1
...	BT 395	Spider bolt	5/16"-18x1 1/2"	4
...	BM 20118	Hub		1
...	BM 62872	Hub gasket		1
...	BM 30172	Spindle	1/2"-18 thread	1
...	BM 28538	Spindle shim		1
...	BM 18091	Spindle nut	1/2"-18x1 1/2"	1
...	BM 33176	Spindle spring		1
...	BM 306	Spindle ball	9/16"	1
...	BM 30177	Ball retainer		1
...	BM 120	Pipe plug	1/2" ext. head	1
...	BM 29022	Exhaust valve screw	1/2"-13x1 1/2"	1
...	BM 2337	Supporting arm screw	1/2"-13x1 1/2"	1
...	BM 28988	Belt		1

MOTOR

Illus. No.	Part No.	Description	Specifications	No. Req.
...	CM 20200	MOTOR ASSEMBLY		1

CYLINDER

Illus. No.	Part No.	Description	Specifications	No. Req.
...	CM 20050	CYLINDER ASSEMBLY AND PISTONS COMPLETE		1
...	CM 29941	CYLINDER ASSEMBLY		1
...	BM 13194	Welch plug	1 1/4"	5
...	BM 14112	Welch plug	1"	2
...	BM 29906	Rocker arm push rod guide—lower		6
...	BM 29902	Exhaust valve stem guide		6
...	BM 29853	Taget guide		12
...	BM 29916	Cylinder head stud—short		7
...	BM 29915	Cylinder head stud—long		16
...	BY 551	Cylinder head stud nut		20
...	BM 51758	Cylinder head stud extension nut		3
...	BM 13143	Exhaust manifold stud	1/2"-16x1-21/32"	12
...	BM 110	Exhaust manifold stud nut	1/2"-16x1/2"	12
...	BM 18288	Cylinder side plate stud		4
...	BM 9542	Cylinder side plate stud nut	1/2"-16x1/2"	4
...	BM 30088	Cylinder side plate stud nut gasket		4
...	BM 13149	Fan lever stud		1
...	BM 2334	Fan lever stud gasket		1
...	BM 29630	Cylinder water outlet washer		2
...	BM 29960	Cylinder to crankcase gasket		1

When ordering give letter prefix with symbol number—Example: CX 28960.

CYLINDER (Continued)				
Illus. No.	Part No.	Description	Specifications	No. Req.
...	BM 18118	Drain cock		1
...	BM 30287	Cylinder head indicator plug		1
...	CM 20041	FRONT SIDE PLATE AND GASKET ASSEMBLY		1
...	CM 20045	REAR SIDE PLATE AND GASKET ASSEMBLY		1
...	BM 25304	Front gasket		1
...	BM 25305	Rear gasket		1
...	BM 13072	Horn bracket stud	5-16" x 18x 1/4"	2
...	BZ 122	Horn bracket stud nut	5-16" x 18x 1/4"	2

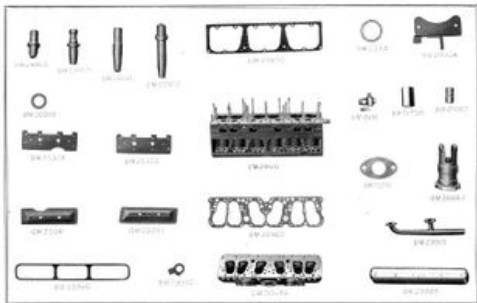

Cylinder Group

CYLINDER HEAD

...	CM 20049	CYLINDER HEAD ASSEMBLY (Includes Welch plugs, studs and guides)		1
...	BM 28863	Cylinder head gasket		1
...	BM 9751	Welch plug		3
...	BM 52317	Rocker arm bracket stud	5/16" x 16x 1/2"	12
...	BM 110	Rocker arm bracket stud nut	5/16" x 16x 1/2"	12
...	BM 28382	Rocker arm bracket stud nut lock plate		12
...	BM 29901	WATER OUTLET MANIFOLD ASSEMBLY		1
...	BM 28036	Water outlet manifold gasket		2
...	BM 52317	Water outlet manifold stud		4
...	BM 110	Water outlet manifold stud nut		4
...	BM 29021	Inlet valve stem guide		6
...	BM 29905	Rocker arm push rod guide—upper		6
...	BM 29907	Cylinder head dowel		2
...	BM 28045	Cylinder head cover		1
...	BM 28046	Cylinder head cover gasket		1
...	BM 70158	Cylinder head cover bolt	5-16" x 18x 3/4"	3
...	BM 29934	Coil bracket		1
...	BM 3925	Cable tube clip stud	5-16" x 18x 1/4"	2
...	BZ 122	Cable tube clip stud nut	5-16" x 18x 1/4"	2

When ordering give letter prefix with symbol number—Example: CX 28900.

CRANKCASE

Illus. No.	Part No.	Description	Specifications	No. Req.
		CRANKCASE COMPLETE		1
...	CM 30229	CRANKCASE AND BEARINGS ASSEMBLY		1
...	CM 30238	Welch plug	1 1/2"	1
...	BM 13193	Crankcase to cylinder stud—long	1/2"-13x3-9 1/16"	6
...	GM 23169	Crankcase to cylinder stud—short	1/2"-13x2 1/2"	7
...	GM 13138	Crankcase to cylinder stud nut	1/2"-13	13
...	BM 508	Crankcase to cylinder stud—medium	1/2"-13x3 1/2"	2
...	BM 29911	Crankcase to cylinder stud nut	1/2"-13x3 1/2"	2
...	BM 70240	Front bearing stud—long	1/2"-12and -20x4-27 3/32"	2
...	BM 15090	Front bearing stud—short	1/2"-12and -20x3-27 3/32"	2
...	BM 15091	Middle bearing stud	1/2"-12and -20x4-31 3/32"	4
...	BM 23569	Rear bearing bolt—long	1/2"-20x4 1/2"	2
...	BM 15093	Rear bearing bolt—short	1/2"-20x3 1/2"	2
...	BM 15094	Bearing studs and bolts washer	1/2"-20x3 1/2"	12
...	BM 18399	Bearing studs and bolts nut	1/2"-20x3 1/2"	12
...	BM 18382	Flywheel pointer	1/2"-20x7 1/16"	1
...	GM 13120	Flywheel pointer screw	1/2"-20x7 1/16"	2
...	BM 12490	Oil indicating level plate		1
...	GM 20062	Starter operating shaft front bushing		1
...	GM 23158	Starter operating shaft rear bushing		1
...	GM 23157	Starter operating shaft rear bushing bolt	5/16"-18x1 1/2"	1
...	BM 219	Starter gear cover		1
...	BM 13100	Starter gear cover spring		1
...	BM 13101	Starter gear cover spring bolt	5/16"-18x1 1/2"	1
...	RZ 12275	Crankcase to generator bolt		3
...	BM 4916	Generator adjusting plug	1"-18x1"	3
...	GM 13115			3

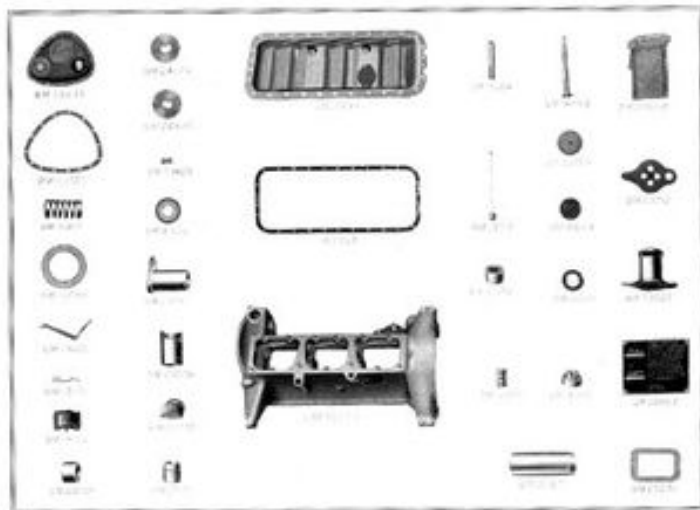

Crankcase Group

When ordering give letter prefix with symbol number—Example: CX 28960.

OIL FILLER AND LEVEL INDICATOR

Illus. No.	Part No.	Description	Specifications	No. Req.
...	BM 23707	OIL FILLER AND VENT ASSEMBLY (Includes 23710, 23708 and 23709)		1
...	BM 23710	Oil filler cover		1
...	BM 16977	Oil filler cover spring		1
...	EM 23714	Oil filler cover screw	$\frac{1}{8}$ "-20x1 $\frac{1}{4}$ "	1
...	GM 23708	Vent tube		1
...	GM 23709	Vent tube cover		1
...	GM 14666	Filler tube		1
...	BM 13719	Oil level indicator		1
...	GM 28847	Oil level indicator glass		1
...	BM 13087	Oil level indicator plate		1
...	GM 13084	Oil level indicator tube guide		1
...	BM 16609	Oil level indicator washer—upper		1
...	EM 13085	Oil level indicator washer—lower		1
...	BM 13086	Oil level indicator glass cup		1

CRANKCASE FRONT COVER

...	BM 23665	FRONT COVER COMPLETE (Includes parts 23663 to 13797 inclusive)		1
...	23663	Front cover (Not sold separately)		1
...	GM 24978	Front cover silencer		1
...	GM 24975	Front cover silencer plate		1
...	BM 23625	Front cover camshaft thrust plate		1
...	BS 9956	Front cover plug	1 $\frac{1}{2}$ "-20	1
...	BS 9957	Front cover plug gasket		1
...	BM 13797	Front cover left washer		1
...	BM 23622	Front cover gasket		1
...	BT 395	Front cover bolt	5-16-18x $\frac{1}{4}$ "	15

MOTOR BOLTS

...	BM 4359	Front motor bolt	$\frac{1}{8}$ "-20x1 $\frac{1}{2}$ " special	2
...	BZ 72	Front motor bolt nut	$\frac{1}{8}$ "-20	2
...	BM 4357	Front motor bolt spring		2
...	BM 4358	Front motor bolt spring seat		2
...	GZ 233	Rear motor bolt	$\frac{1}{8}$ "-20x1 $\frac{1}{2}$ " special	4
...	BZ 72	Rear motor bolt nut	$\frac{1}{8}$ "-20	4
...	BM 20151	Front motor support rubber pad		2
...	BM 20152	Rear motor support rubber pad		2

OIL RESERVOIR

...	CM 10134	OIL RESERVOIR ASSEMBLY		1
...	BM 70178	Drain plug	$\frac{1}{4}$ " socket type	1
...	BM 13126	Gasket		1
...	BM 8203	Oil reservoir to crankcase screw	$\frac{1}{8}$ "-16x $\frac{1}{4}$ "	20
...	BM 29949	FILTER SCREEN ASSEMBLY		1
...	BM 60023	Gasket		1
...	BM 62376	Baffle		1

CRANKSHAFT AND CAMSHAFT GROUP

...	BM 33242	CRANKSHAFT ASSEMBLY (Includes parts to 3433 inclusive)		1
...	GM 33208	Counterweight Nos. 1, 3, 4 and 8		4
...	GM 33909	Counterweight Nos. 2 and 7		2
...	GM 33210	Counterweight Nos. 4 and 5		2
...	BM 33236	Counterweight stud—medium	$\frac{1}{8}$ "-20x3 $\frac{1}{4}$ "	6
...	BM 33237	Counterweight stud—short	$\frac{1}{8}$ "-20x2 $\frac{1}{4}$ "	12
...	BY 3433	Counterweight stud nut	$\frac{1}{8}$ "-20x7 $\frac{1}{4}$ "	20
...	BM 28986	Starting crank jaw		1
...	BM 28989	Fan pulley—"V" type		1
...	BM 23617	Fan pulley washer		1
...	GZ 636	Fan pulley key	No. 11 Woodruff	1
...	CM 28967	Camshaft		3
...	BM 22331	Thrust washer		1
...	EM 13013	Shim—thin		1
...	BM 8149	Shim—thick		7
...	BM 23619	Thrust button		1
...	BM 23620	Thrust button spring		1
...	BM 23621	Thrust button cup		1
...	BM 23289	Thrust button cup washer		1

When ordering give letter prefix with symbol number—Example: CX 28960.

FLYWHEEL

Illus. No.	Part No.	Description	Specifications	No. Req.
...	CM 28348	Flywheel		1
...	BM 24183	Flywheel bolt	$\frac{1}{2}$ "-20x1-13-32"	4
...	BY 3433	Flywheel bolt nut	$\frac{1}{2}$ "-20x7/16"	4



Crankshaft and Camshaft Group

VIBRATION DAMPENER

...	BM 29972	VIBRATION DAMPENER ASSEMBLY		1
...	BM 29891	Inner ring		1
...	BM 29892	Outer ring		1
...	BM 29894	Facing		2
...	BM 29893	Facing plate		1
...	BM 70242	Facing plate cap screw	Flat head $\frac{1}{4}$ "-20x $\frac{1}{2}$ "	2
...	BM 29895	Spring		8

TIMING SPROCKETS AND CHAIN

...	BM 28849	Crankshaft sprocket		1
...	BM 11799	Crankshaft sprocket key	Woodruff No. "A"	1
...	BM 23607	Camshaft sprocket		1
...	BM 70906	Camshaft sprocket screw	$\frac{1}{2}$ "-14x $\frac{1}{2}$ "	2
...	BM 23608	Water pump shaft sprocket		1
...	BM 23627	Drive chain		1

CRANKSHAFT BEARINGS

...	GM 30202	Front bearing cap		1
...	GM 30203	Front middle bearing cap		1
...	GM 30204	Rear middle bearing cap		1
...	GM 30206	Rear bearing cap		1
...	GM 30206	Middle bearing caps plate		2
...	BM 13549	Front and rear bearing caps packing		2
...	BM 30211	Front bearing—upper		1
...	BM 30212	Front bearing—lower		1
...	BM 30213	Front middle bearing—upper		1
...	BM 30214	Front middle bearing—lower		1
...	BM 30215	Rear middle bearing—upper		1
...	BM 30216	Rear middle bearing—lower		1

When ordering give letter prefix with symbol number—Example: CX 20940.

CRANKSHAFT BEARINGS (Continued)

Illus. No.	Part No.	Description	Specifications	No. Req.
...	BM 30337	Rear bearing—upper		1
...	BM 30338	Rear bearing—lower		1
...	BM 30335	Bearing machine screw	$\frac{1}{2}$ "-20x $\frac{1}{2}$ "	8
...	BM 30219	Front bearing shim	.002	4
...	BM 30220	Front bearing shim	.005	2
...	BM 30221	Front bearing shim	.0125	8
...	BM 30222	Middle bearing shim	.002	8
...	BM 30223	Middle bearing shim	.005	4
...	BM 30224	Middle bearing shim	.0125	16
...	BM 30225	Rear bearing shim	.002	4
...	BM 30226	Rear bearing shim	.005	2
...	BM 30227	Rear bearing shim	.0125	2

CAMSHAFT BEARINGS

...	BM 13033	Front bearing		1
...	GM 12411	Front bearing dowel pin	$\frac{1}{8}$ "x $\frac{1}{2}$ "	1
...	BM 13027	Front middle bearing		1
...	BM 13029	Rear middle bearing		1
...	BM 13036	Rear bearing		1
...	BM 12237	Front and rear middle bearing dowel pin		2
...	GO 12354	Rear bearing dowel pin	$\frac{1}{8}$ "x $\frac{1}{2}$ "	1

INTAKE MANIFOLD

...	BM 29669	Intake manifold		1
...	BM 29936	Intake manifold gasket		1
...	BM 29923	Intake manifold to riser gasket		1
...	GZ 384	Intake manifold cap screw	$\frac{1}{2}$ "-16x1 $\frac{1}{2}$ "	4
...	BM 20241	Intake manifold cap screw	5-16-15x3"	2
...	GO 12214	Intake manifold elbow	$\frac{1}{2}$ " pipe x7-16-20	1
...	BM 29952	Damper control lever—inner		1
...	BM 29953	Damper control lever—outer		1
...	BM 29953	Damper control shaft		1
...	GZ 4595	Taper pin	No. 60x $\frac{1}{2}$ "	2



Intake and Exhaust Manifold Group

EXHAUST MANIFOLD

...	CM 29868	Exhaust manifold		1
...	BM 29910	Gasket—single		2
...	BM 29809	Gasket—double		2
...	BM 20239	Stud	$\frac{1}{2}$ "-16x1 $\frac{1}{2}$ "	2
...	BM 20247	Stud nut	$\frac{1}{2}$ "-16x $\frac{1}{2}$ " Brass	2
...	BM 22286	Packing		3
...	BM 8228	Packing nut		1
...	BM 29623	Riser gasket		1
...	BM 29363	Damper gasket		1
...	BM 29929	Outlet tube		1
...	BM 29931	Outlet tube packing		4
...	BM 29933	Outlet tube packing nut		2
NOTE: The exhaust damper assembly and all its parts will be serviced directly through the Marvel Carburetor Company, Flint, Michigan.				
...	BM 29364	Damper operating rod		1
...	BZ 5771	Adjustable yoke	3-16"	1
...	BZ 5825	Clevis pin	3-16"x11-16"	1
...	BZ 12789	Nut	No. 10-32x $\frac{1}{2}$ "	1
...	BM 29935	Air cleaner support arm		1

When ordering give letter prefix with symbol number—Example: CX 28860.

VALVES

Illustr. No.	Part No.	Description	Specifications	No. Req.
...	BM 29004	Inlet valve		4
...	BM 29021	Inlet valve stem guide		4
...	BM 29338	Inlet valve spring—outside		4
...	BM 29339	Inlet valve spring—inside		4
...	BM 29034	Inlet valve spring seat		4
...	BM 29953	Exhaust valve		4
...	BM 29992	Exhaust valve stem guide		4
...	BM 29845	Exhaust valve spring		4
...	BM 13043	Exhaust valve spring seat		4
...	BM 29341	Valve spring seat retainer		12



Valve and Tappet Group

VALVE TAPPET

...	BM 29846	VALVE TAPPET AND GUIDE ASSEMBLY		12
...	BM 29854	Tappet		12
...	BM 29853	Tappet guide		12
...	BM 29848	Roller		12
...	BM 29848	Roller pin		12
...	BM 28537	Adjusting screw		12
...	BM 23294	Adjusting screw seat		12
...	BM 60999	Adjusting screw plate		12
...	BM 29842	Guide locating washer		6
...	BM 13050	Guide clamp		6

ROCKER ARM AND PUSH ROD

...	BM 29876	Rocker arm		6
...	BM 29877	Rocker arm bracket		6
...	BM 50185	Hyatt roller bearing		6
...	BM 29018	Pivot	7/16"-20x29 64"	6
...	BR 3488	Pivot nut		6
...	BM 29019	Pivot washer		6
...	BM 29027	Silencing spring		6
...	BM 29028	Silencing spring cup		6
...	CY 253	Silencing spring cup bolt	1/4"-20x1 1/2"	6
...	BM 51759	Oiler		6
...	RY 14164	Oiler nut	7/8"-24x3 3/4"	6
...	BM 29912	Push rod		6
...	BM 29905	Push rod guide—upper		6
...	BM 29906	Push rod guide—lower		6
...	BM 29339	Push rod spring		6

When ordering give letter prefix with symbol number—Example: CX 29860.

ADJUSTING ECCENTRIC AND WATER PUMP GROUP

Illustr. No.	Part No.	Description	Specifications	No. Req.
....	BM 23609	ADJUSTING ECCENTRIC ASSEMBLY (Includes parts 23712 to 2704 inclusive excepting 27436)		1
....	23712	Eccentric body (Not sold separately)		1
....	BM 27436	Eccentric body gasket		1
....	BM 23714	Eccentric body bushing		1
....	BM 3637	Eccentric body bushing dowel pin	$1/2 \times 3/8$	1
....	BM 23713	Eccentric		1
....	GO 18318	Eccentric bolt	$1/2 \times 20 \times 1/2$	3
....	BM 39319	Water pump drive shaft		1
....	BM 23702	Water pump drive shaft thrust washer		1
....	BM 18183	Water pump drive shaft thrust washer screw	No. 8-32 $\times 1/2$	3
....	BM 24792	Water pump sprocket thrust washer		1
....	BM 18184	Water pump sprocket thrust washer dowel pin	$1/2 \times 7/16$	1
....	BM 23701	Water pump sprocket thrust washer spring		3
....	BM 23629	Floating coupling		1
....	BM 23628	Stationary coupling		1
....	BZ 115	Stationary coupling key	Woodruff No. 9	1
....	BM 16327	Stationary coupling pin	$2 \times 16 \times 1/2$	1
....	BM 21438	Generator coupling		1
....	BM 23116	Generator coupling clamp		4
....	GO 18228	Generator coupling clamp bolt	$1/2 \times 28 \times 2$	2
....	BM 794	Generator coupling clamp bolt nut	$1/2 \times 28 \times 32$	2
....	GM 23182	Generator coupling sleeve		1
....	BZ 115	Generator coupling sleeve key	Woodruff No. 9	1
....	BM 39321	WATER PUMP BODY ASSEMBLY (Includes bushing)		1
....	BM 36294	Water pump body bushing		1
....	BM 3637	Water pump body bushing dowel pin		1
....	BM 271	Water pump body bolt	$1/2 \times 20 \times 1/2$	5
....	BM 272	Water pump body bolt nut	$1/2 \times 20 \times 1/2$	5
....	BM 13227	Water pump body to cylinder gasket		1
....	BZ 12275	Water pump body to cylinder bolt	$5 \times 16 \times 18 \times 1/2$	1
....	BM 79225	Water pump body to cylinder bolt gasket		1
....	GO 18062	Water pump body to crankcase bolt	$5 \times 16 \times 18 \times 1/2$	3
....	BM 33222	WATER PUMP COVER ASSEMBLY (Includes bushing)		1
....	BM 33286	Water pump cover bushing		1
....	BM 3637	Water pump cover bushing dowel pin	$1/2 \times 3/8$	1
....	BM 14941	Water pump cover gasket		1
....	BM 33291	Water pump paddle		1
....	BM 12213	Water pump paddle taper pin	No. 3 $\times 1/2$	1
....	BZ 115	Water pump paddle key	Woodruff No. 9	1
....	BM 18118	Water pump drain cock	$1/2$ pipe	1
....	BM 18192	Water pump grease cup		1
....	BM 33292	Water pump packing nut—front	$1 \times 1/2 \times 18$ Tap L.H. thread	1
....	BM 33293	Water pump packing nut—rear	$1 \times 1/2 \times 18$ Tap L.H. thread	1
....	BM 33296	Water pump packing		2

DISTRIBUTOR DRIVE AND OIL PUMP GROUP

....	BM 23917	DISTRIBUTOR DRIVE SHAFT AND BRACKET ASSEMBLY		1
....	BM 24469	Bracket		1
....	BM 23239	Bracket gasket		1
....	BM 23611	Drive shaft		1
....	BZ 124	Drive shaft nut	$1/2 \times 24 \times 32$	2
....	BM 24468	Drive shaft bushing		1
....	BM 4973	Drive shaft key	Woodruff No. 4	1
....	BM 23613	Drive shaft driven gear	21 teeth	1
....	BM 22691	Distributor gasket		1
....	BM 23185	Drive washer		1
....	BM 18158	Drive washer bolt	$1/2 \times 28 \times 1/2$	1
....	BM 23866	Drive washer bolt lock		1
....	BM 13063	Oil pump drive worm		1
....	BZ 7991	Oil pump drive worm taper pin	No. 9 $\times 1/2$	1
....	BM 29697	OIL PUMP AND DRIVE GLAR HOUSING ASSEMBLY		1
....	BM 23652	Housing		1
....	BM 13073	Housing stud	$5 \times 16 \times 18 \times 1/2$	3
....	BZ 122	Housing stud nut	$5 \times 16 \times 18 \times 1/2$	3
....	BM 204	Housing bolt	$1/2 \times 16 \times 1$	1
....	BK 1398	Housing bolt	$1/2 \times 16 \times 1/2$	2
....	BM 30187	Worm wheel	14 teeth	1
....	BM 24586	Worm wheel shim		1
....	BM 29927	Worm wheel bushing		2
....	BM 30159	Worm wheel shaft		1
....	BM 30158	Bearing		1
....	BM 30687	Bearing gasket		1
....	BM 219	Bearing bolt	$5 \times 16 \times 18 \times 1/2$	2

When ordering give letter prefix with symbol number—Example: CX 28960.



Water Pump and Eccentric Group

OIL PUMP

Illus. No.	Part No.	Description	Specifications	No. Req.
...	BM 30244	OIL PUMP AND PLUNGER ASSEMBLY		1
...	BM 29923	Oil pump body		1
...	BM 13072	Body gasket		1
...	BM 30064	Oil pump oil deflector		1
...	BM 120	Body pipe plug		1
...	BM 101	Steel ball		2
...	BM 30159	Main plunger		1
...	BM 29925	Main plunger spring		1
...	BM 20482	Distributor plunger		1
...	BM 19959	Distributor plunger spring		1
...	CM 19960	Distributor plunger plug		1
...	BM 6791	Distributor plunger plug gasket		1
...	BM 30247	Inlet connection		1
...	BM 18259	Inlet connection gasket		1
...	BM 24333	Bowl		1
...	BM 70285	Steel ball		1



Oil Pump Group

When ordering give letter prefix with symbol number—Example: CX 2090.

OIL PIPES AND FITTINGS

Illus. No.	Part No.	Description	Specifications	No. Req.
...	BM 29879	Filter to crankcase pipe		1
...	BM 5655	Clamp		1
...	BM 3367	Union	$\frac{1}{2}$ "-20 and $\frac{1}{2}$ "-18	1
...	GM 22433	Clip		1
...	BO 18138	Clip screw	No. 10-32x $\frac{1}{2}$ "	1
...	BM 28234	Oil pump to crankcase pipe		1
...	BM 11849	Elbow	$\frac{1}{2}$ "-16	1
...	GO 18197	Clip	$\frac{1}{2}$ "-16	1
...	BM 11829	Elbow	$\frac{1}{2}$ " pipe and $\frac{1}{2}$ "-20	1
...	BM 30623	Oil pump to union pipe		1
...	BM 12114	Elbow	$\frac{1}{2}$ " pipe and 7/16"-20	1
...	BM 33024	Union to gauge pipe		1
...	BM 11842	Oil pump to union and union to gauge pipes union nut		2
...	BO 12112	Oil pump to union and union to gauge pipes union	double	1

MUFFLER AND EXHAUST PIPE

...	A 29957	MUFFLER ASSEMBLY (127" wheelbase)		1
...	A 20112	MUFFLER ASSEMBLY (118" wheelbase)		1
...	CM 28848	Exhaust pipe		1
...	BM 13826	Exhaust pipe covering		2
...	BM 2397	Exhaust pipe covering strap	$\frac{1}{2}$ "-16	1
...	BZ 16498	Exhaust pipe clamp		1
...	CM 28849	Tail pipe (127" wheelbase)		1
...	CM 30114	Tail pipe (118" wheelbase)		1
...	BZ 16496	Tail pipe clamp		1
...	BM 219	Exhaust and tail pipe clamp bolt	$\frac{1}{2}$ "-16x $\frac{1}{2}$ "	4
...	BZ 12275	Exhaust and tail pipe clamp bolt	$\frac{1}{2}$ "-16x1"	2
...	BZ 122	Exhaust and tail pipe clamp bolt nut	$\frac{1}{2}$ "-16x16"	6
...	BZ 28844	Tail pipe clip—front (127" wheelbase)		1
...	BM 30115	Tail pipe clip—front (118" wheelbase)		1
...	BM 18062	Tail pipe clip bolt	$\frac{1}{2}$ "-16x1"	1
...	BZ 122	Tail pipe clip bolt nut	$\frac{1}{2}$ "-16x16"	1
...	BZ 56709	Tail pipe clip (Attaches to gas tank strap)		1
...	BZ 56710	Tail pipe clip cap		1
...	BZ 12275	Tail pipe clip cap bolt	$\frac{1}{2}$ "-16x1"	1
...	BZ 122	Tail pipe clip cap bolt nut	$\frac{1}{2}$ "-16x16"	1

CLUTCH

(Maters 476679 to 529702)

...	BR 30130	CLUTCH ASSEMBLY		1
1	BR 30131	Cover		1
2	BZ 508	Cover bolt	$\frac{1}{2}$ "-16x $\frac{1}{2}$ " U.S.S. hex. head	8
3	BR 70133	Cover pipe plug	$\frac{1}{2}$ " socket type	1
4	BR 29361	Cover gasket		1
5	BR 29580	DRIVING PLATE ASSEMBLY (Includes hub)		1
6	BR 598	Driving plate cork		132
7	BR 29352	Pressure plate		1
8	BT 395	Pressure plate cap screw	$\frac{1}{2}$ "-16x $\frac{1}{2}$ " U.S.S. hex. head	8
9	BR 29523	Pressure plate cap screw lock plate		6
10	BR 29356	Toggle bracket		4
11	BM 18404	Toggle bracket nut	2-16"-20x17-32" U.S.S. slotted head	4
12	BR 62282	Toggle bracket gasket		4
13	BR 62288	Toggle arm pin		4
14	BR 62289	Toggle arm link plate		4
15	BR 29355	Shifter finger		4
16	BR 30133	Shifter plate		1
...	BR 30271	Reset	$\frac{1}{2}$ "x $\frac{1}{2}$ " button head	2
17	BR 79137	Thrust bearing	New Departure No. 6230	1
18	BR 30015	THRUST BEARING RETAINER ASSEMBLY		1
19	BZ 9773	Thrust bearing retainer pipe plug	$\frac{1}{2}$ " headless	1
20	BR 29360	Thrust bearing retainer washer		1
21	BR 29362	Thrust bearing retainer oil hole seal		1
22	BR 30591	SHIFTING SLEEVE AND BEARING ASSEMBLY		1
...	BR 30128	SHIFTING SLEEVE ASSEMBLY		1
23	BR 29319	Main spring		12

When ordering give letter prefix with symbol number—Example: CX 28960.

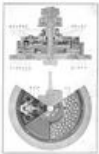

Clutch (Continued)
(Motors 529792 and upward)

Illus. No.	Part No.	Description	Specifications	No. Req.
	RR 30745	CLUTCH ASSEMBLY		1
1	RR 30131	Cover		1
2	BZ 998	Cover bolt	$\frac{1}{2}$ "-18x $\frac{1}{2}$ "	8
3	RR 30132	Cover pipe plug	$\frac{1}{2}$ " socket type	1
4	RR 29361	Cover gasket		1
5	RR 29560	DRIVING PLATE ASSEMBLY		1
6	RR 590	Driving plate cork		132
7	RR 29322	Pressure plate		1
8	BT 396	Pressure plate cap screw	$\frac{1}{2}$ "-18x $\frac{1}{2}$ "	8
9	RR 29523	Pressure plate cap screw lock plate		4
10	RR 29526	Toggle bracket		4
11	RM 14464	Toggle bracket nut	$\frac{1}{2}$ "-20x $\frac{1}{2}$ "	4
12	RR 62282	Toggle bracket gasket		4
13	RR 62288	Toggle arm pin		4
14	RR 62289	Toggle arm lock plate		4
15	RR 30742	Shifter finger		1
16	RR 30743	Shifter plate		14
RR 70441	Rivet			2
17	RR 70137	Thrust bearing	New Departure No. 9216	1
18	RR 30015	THRUST BEARING RETAINER ASSEMBLY		1
19	BZ 9773	Thrust bearing retainer pipe plug	$\frac{1}{2}$ " headless	1
20	RR 29340	Thrust bearing retainer washer		1
21	RR 29362	Thrust bearing retainer oil seal		1
22	RR 30742	SHIFTING SLEEVE, BEARING AND RETAINER ASSEMBLY		1
RR 30718	Shifting sleeve			1
23	RR 29359	Main spring		12

TRANSMISSION

	CT 29346	TRANSMISSION ASSEMBLY	4-1 12 to 1 R.A. ratio	1
	CT 29654	TRANSMISSION ASSEMBLY	4-5 11 to 1 R.A. ratio	1
1	CT 29712	Transmission case		1
	BT 22812	Case cover gasket		1
2	BS 9956	Case drain plug	$\frac{1}{2}$ "-20	1
3	BS 9957	Case drain plug gasket		1
4	BZ 2346	Case oil level pipe plug	$\frac{1}{2}$ " extension head	1
5	BT 10648	Case bearings lock screw		2
6	BT 29371	Main shaft drive gear		1
7	BT 87	Main shaft drive gear steel ball		1
8	BT 70138	Main shaft drive gear outer ball bearing	N. D. 1300	1
9	BT 29373	Main shaft drive gear inner bushing		1
10	BT 70138	Main shaft drive gear pilot ball bearing	N. D. 1204	1
11	BT 29382	Front bearing cap		1
12	BT 22807	Front bearing cap gasket		1
13	RM 324	Front bearing cap screw	$\frac{1}{2}$ "-16x1"	4
14	BT 33162	Front bearing cap oil seal		1
15	BT 29572	Main shaft		1
16	G F 3314	Main shaft nut	$\frac{1}{2}$ "-16x9 16' slotted head	1
17	BT 2751	Main shaft nut washer		1
18	BT 16246	Main shaft high and intermediate gear	25 teeth	1
19	BT 8659	Main shaft low and reverse gear	31 teeth	1
20	BT 9838	Main shaft rear bearing		1
21	BT 9831	Main shaft rear bearing front steel washer		1
22	BT 9832	Main shaft rear bearing rear steel washer		1
23	BT 10927	Main shaft rear bearing shim—thin	.010" thick, square hole	1
	G T 10926	Main shaft rear bearing shim—thick	.020" thick, square hole	1
	G T 29527	REAR BEARING CAP ASSEMBLY	4-5 11 to 1 ratio	1
	CT 29345	REAR BEARING CAP ASSEMBLY	4-5 12 to 1 ratio	1
24	BT 22745	Rear bearing cap		1
25	BT 6457	Rear bearing cap felt washer		1
26	BT 9828	Rear bearing cap gasket		1
27	BT 9829	Rear bearing cap screw	$\frac{1}{2}$ "-16x1"	2
27	BT 9833	Rear bearing cap bronze washer	.010" thick, square hole	1
28	BT 10965	Rear bearing cap bronze washer dowel pin	$\frac{1}{8}$ "-5 16'	1
29	BT 10964	Rear bearing cap oil guide		1
	G F 3854	Rear bearing cap oil guide rivet	Button head $\frac{1}{8}$ "x $\frac{1}{2}$ "	1
30	BT 9820	Rear bearing cap shim	.005"	1
30	BT 9821	Rear bearing cap shim	.010"	1
30	BT 9822	Rear bearing cap shim	.016"	1
31	BT 29079	Speedometer drive gear	4-5 12 to 1 R. A. ratio	1
31	BT 29042	Speedometer drive gear	4-5 11 to 1 R. A. ratio	1
32	GO 23071	Speedometer drive gear washer		1
33	BT 22942	Speedometer drive gear spacer		1
	BT 29078	Speedometer drive pinion	4-1 12 to 1 R. A. ratio	1

When ordering give letter prefix with symbol number—Example: CX 28960.



TRANSMISSION (Continued)

Illus. No.	Part No.	Description	Specifications	No. Req.
34	BT 2381	Speedometer drive pinion	4-5-11 to 1 R. A. ratio	1
35	BT 2387	Speedometer drive pinion sleeve		1
36	BT 27253	Speedometer drive pinion shim		1
37	BT 9805	Countershaft		1
38	BT 9817	Countershaft bearing		2
39	G.T. 9825	Countershaft bearing cap		2
40	BT 9827	Countershaft bearing cap gasket		2
	BM 304	Countershaft bearing cap bolt	3/8"-16x1"	6
41	BT 10171	Countershaft bronze washer		2
42	BT 10170	Countershaft steel washer		2
43	BT 10654	Countershaft shim—rear end	.005"	1
43	BT 10683	Countershaft shim—rear end	.010"	1
43	BT 10682	Countershaft shim—rear end	.016"	1
44	BT 296	Countershaft gear key	Woodruff No. 18	4
45	BT 14349	Countershaft driver gear	33 teeth	1
46	BT 14350	Countershaft second gear	22 teeth	1
47	BT 355	Countershaft low gear	17 teeth	1
48	BT 9612	Countershaft reverse gear	14 teeth	1
49	G.T. 357	Countershaft gear spacing collar		1
50	BT 9811	Reverse idler gear		1
51	BT 7478	Reverse idler gear bearing		1
52	BT 9806	Reverse idler gear shaft		1
53	BT 24523	Reverse idler gear thrust washer		1
54	BT 29119	CLUTCH THROWOUT YOKE ASSEMBLY—Motos 479679 to 529792		1
	BT 30783	CLUTCH THROWOUT YOKE ASSEMBLY—Motos 529792 and upward		1
	BT 24473	Clutch throwout yoke bushing		1
	BT 24472	Clutch throwout yoke bolt	1/2"-20x2 1/2"	1
	BY 3433	Clutch throwout yoke bolt nut	1/2"-20x7 1/8"	1
55	BM 4946	Transmission to crankcase bolt	1/2"-13x2	2
56	BT 11808	Transmission to crankcase shoulder bolt	1/2"-20x3-1/2 1/4"	1
	BT 11807	Transmission to crankcase bolt	1/2"-20x4 1/2"	1
57	B.Z. 72	Transmission to crankcase bolt nut	1/2"-20x9 1/8"	3
58	BO 18161	Starter pedal stop set screw	5/16"-18x 1/2"	1
59	B.Z. 122	Starter pedal stop set screw nut	5/16"-18x 1/2"	1

CONTROL LEVERS

	BS 30065	CONTROL LEVER ASSEMBLY		1
1	BS 24981	Gear shift lever		1
2	BS 24989	Gear shift lever key		1
3	BS 22840	Gear shift lever pin		1
4	BS 22838	Gear shift lever spring		1
5	BS 22839	Gear shift lever spring seat		1
6	BS 22842	Gear shift lever cover		1
7	BS 3037	Gear shift lever cover taper pin	No. 2x1"	1
8	BS 30653	Gear shift lever cover silencer		1
9	BS 22843	Gear shift lever ball cup		1
10	BS 22837	Gear shift lever felt washer		1
	BS 29170	Gear shift lever ball		1
13	BS 30692	Gear shift lever housing		1
14	BS 22844	Gear shift lever housing gasket		1
	BM 219	Gear shift lever housing bolt	5/16"-18x1 1/2"	1
	BS 29073	TRANSMISSION CASE COVER		1
B.Z. 12275	Transmission case cover cap screw	5/16"-18x1"		8
GO 18096	Transmission case cover clevis pin	3/16"x1 1/2"		1
BS 22852	Second and high gear shifting shaft			1
BS 22851	Low and reverse gear shifting shaft			1
BS 22853	Shifting shafts lock			2
BM 316	Shifting shafts lock ball	9/16"		2
BS 22856	Shifting shafts lock ball spring			2
BS 22859	Shifting shafts lock ball spring cap	1/2"-16 thread		2
BS 22854	Shifting fork			2
BS 22855	Shifting fork screw	5/16"-24 thread		2
	B.Z. 22871	STARTER PEDAL		1
B.Z. 1015	Starter pedal taper pin	No. 2x1 1/2"		1
B.Z. 22870	Starter pedal shaft			1
B.Z. 142	Starter pedal shaft key	Woodruff No. 6		2
G.Z. 22873	Starter pedal shaft lever			1
B.Z. 1015	Starter pedal shaft lever taper pin	2"x1 1/2"		1
G.Z. 718	Starter pedal shaft lever clevis pin			1
BS 13294	Starter pedal shaft lever spring			1
G.S. 13293	Starter pedal shaft lever spring clip			1
G.Z. 22874	Starter pedal operating rod			1

When ordering give letter prefix with symbol number—Example: CX 23860.

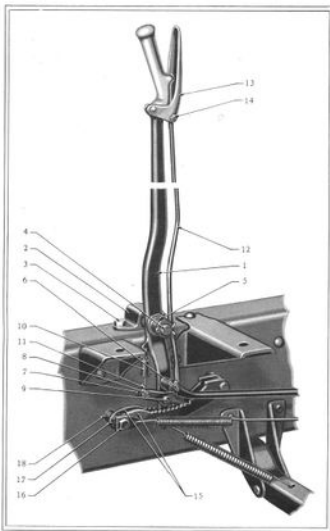

HAND BRAKE LEVER

Hub. No.	Part No.	Description	Specifications	No. Req.
	BS 29065	HAND BRAKE LEVER ASSEMBLY		1
1	BS 29067	Hand brake lever		1
	BS 62331	Hand brake lever bushing		1
2	BS 62332	Hand brake lever bracket		1
3	BR 1306	Hand brake lever bracket bolt	$5/8$ "-16x $1\frac{1}{2}$ "	1
	BM 110	Hand brake lever bracket bolt nut	$5/8$ "-16x $1\frac{1}{2}$ "	1
4	BS 62333	Hand brake lever shaft		1
	BS 731	Hand brake lever shaft taper pin	No. 2x1 $\frac{1}{4}$ "	1
5	BS 62334	Brake lever pivot spring		1
6	BS 29071	Hand brake lever pull rod pivot		1
	BR 611	Hand brake lever pull rod front nut	5-16"-24x17-64"	1
7	BS 62327	Latch—inside		1
8	BS 62328	Latch—outside		1
9	BZ 8683	Latch clevis pin	5-16"x1"	1
	BM 12660	Latch clevis pin	$\frac{1}{2}$ "x39-64"	1
10	BS 62329	Latch spring		1
11	BS 62330	Latch spring hook		1
12	BS 29069	Latch rod		1
13	BS 22841	Latch grip		1
14	BS 12123	Latch grip screw	No. 10-32x13-16"	1
	BS 7435	Latch grip screw nut	No. 10-32x $1\frac{1}{2}$ "	1
15	BS 62872	Ratchet		2
16	BS 6706	Ratchet bolt	$5/8$ "-16x2 $\frac{1}{2}$ "	2
	BM 110	Ratchet bolt nut	$5/8$ "-16x $2\frac{1}{2}$ "	2
17	BS 62325	Ratchet spacer		2
18	BS 62326	Ratchet frame spacer		2

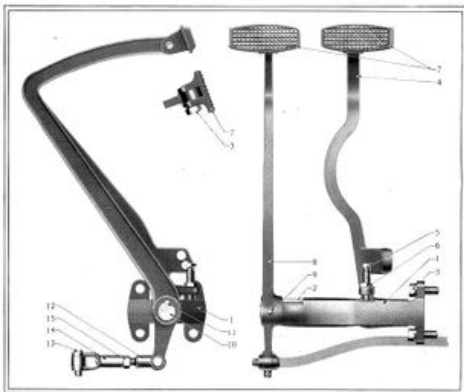

Pedal Control
(Motor 478679 to 529702)

When ordering give letter prefix with symbol number—Example: CX 28946.

PEDAL CONTROL

(Motors 478679 to 529302)

Illus. No.	Part No.	Description	Specifications	No. Req.
...	GZ 29325	PEDAL CONTROL ASSEMBLY		1
1	BZ 24889	PEDAL BRACKET ASSEMBLY (includes bushing)		1
2	GZ 24858	Pedal bracket bushing		2
3	BR 1308	Pedal bracket bolt	$\frac{1}{2}$ "-16x1 $\frac{1}{2}$ "	4
4	GZ 29290	Brake pedal		1
...	BZ 25447	Brake pedal bushing		1
5	BR 18341	Brake pedal set screw	$\frac{1}{4}$ "-18x1 $\frac{1}{2}$ "	1
6	BZ 5432	Brake pedal set screw nut	$\frac{1}{4}$ "-16x3 1/4"	1
7	GZ 30318	Brake pedal pad		1
...	BR 1326	Brake pedal pad bolt	$\frac{1}{2}$ "-16x1 $\frac{1}{2}$ "	1
8	GZ 29537	Clutch pedal		1
9	BZ 1915	Clutch pedal taper pin	No. 2x1 $\frac{1}{4}$ "	1
...	GZ 30318	Clutch pedal pad		1
...	BR 1328	Clutch pedal pad bolt	$\frac{1}{2}$ "-16x1 $\frac{1}{2}$ "	1
10	GZ 22903	Clutch pedal shaft		1
11	BZ 115	Clutch pedal shaft key	Woodruff No. 9	1
...	BZ 29535	Clutch pedal shaft collar		1
...	BZ 1915	Clutch pedal shaft collar taper pin	No. 2x1 $\frac{1}{4}$ "	1
...	BZ 13542	Clutch pedal spring		1
12	BZ 29543	Clutch pedal link		1
13	BY 3212	Clutch pedal link clevis pin	$\frac{1}{2}$ "x1-3 3/4"	1
14	BZ 29549	Clutch pedal adjustable link		1
15	BZ 62	Clutch pedal adjustable link nut	$\frac{1}{2}$ "-24x23 64"	1
...	BY 3212	Clutch pedal adjustable link clevis pin	$\frac{1}{2}$ "x15 3/4"	1



Pedal Control

(Motors 529302 and upward)

When ordering give letter prefix with symbol number—Example: CX 28960.

PEDAL CONTROL (Continued)

(Motors 529702 and upward)

Illus. No.	Part No.	Description	Specifications	No. Req.
	GZ 20746	PEDAL CONTROL ASSEMBLY		1
1	BZ 24809	PEDAL BRACKET ASSEMBLY (Includes bushing)		1
	GZ 24888	Pedal bracket bushing		2
	BR 1308	Pedal bracket bolt		4
2	GZ 24090	Brake pedal		1
	BZ 25447	Brake pedal bushing		1
	3 BX 18341	Brake pedal set screw		1
	4 BZ 5407	Brake pedal set screw nut		1
5	GZ 30118	Brake pedal pad		1
	BR 1308	Brake pedal pad bolt		1
7	GZ 20741	Clutch pedal		1
	BZ 1315	Clutch pedal taper pin		1
8	GZ 30118	Clutch pedal shaft lever		1
9	BR 1308	Clutch pedal pad bolt		1
10	GZ 22901	Clutch pedal shaft		1
11	BZ 1315	Clutch pedal shaft key		1
12	BZ 30544	Clutch pedal shaft lever		1
	BZ 1515	Clutch pedal shaft lever taper pin		1
13	BZ 13542	Clutch pedal spring		1
14	BZ 29544	Clutch pedal link		1
15	BY 3212	Clutch pedal clevis pin		1
16	BZ 23521	Clutch pedal adjustable link		1
	BZ 62	Clutch pedal adjustable link nut		1
17	BY 3212	Clutch pedal adjustable link clevis pin		1

VACUUM TANK CONNECTIONS AND GASOLINE PIPES

NOTE: We do not carry in stock vacuum tank assemblies or service parts for them. All matters pertaining to replacements should be taken up direct with the Stewart-Warner Speedometer Corp., Chicago, Ill.

...	BM 12170	Vacuum tank to dash bolt	20x1 1/2"	4
...	BM 272	Vacuum tank to dash bolt nut	20x1 1/2"	4
...	BM 11829	Union elbow	1/2" pipe x 1/2"-20	1
...	GO 23896	Inlet bushing assembly (Includes screen)	1/2" pipe x 7/16"-20	1
...	GO 12314	Union elbow	1/2" pipe x 7/16"-20	1
...	BO 18306	Shut-off cock	7/16"-20x 1/2" pipe	1
...	BZ 3128	Drain cock	7/16"-20x 1/2" pipe	1
...	GO 30420	Gas tank to vacuum tank pipe assembly (27" wheelbase)		1
...	GO 30421	Gas tank to vacuum tank pipe assembly (18 1/2" wheelbase)		1
...	BM 11828	Gas tank to vacuum tank pipe union nut	1/2"-20x 5/16"	2
...	GO 13733	Gas tank to vacuum tank pipe clip		4
...	BO 12178	Gas tank to vacuum tank pipe clip screw	No. 10-32x 1/2"	7
...	BZ 12799	Gas tank to vacuum tank pipe clip screw nut	No. 10-32x 1/2"	4
...	BM 29542	Vacuum tank to carburetor pipe assembly		1
...	BM 11842	Vacuum tank to carburetor pipe union nut	7/16"-20x 1/2"	2
...	BM 11842	Vacuum tank to manifold pipe assembly		1
...	BM 11842	Vacuum tank to manifold pipe union nut	7/16"-20x 1/2"	2

CARBURETOR

The carburetor and riser assembly and all its parts will be shipped directly through the Marvel Carburetor Company, Flint, Michigan.

ACCELERATOR

...	BZ 61517	Accelerator pedal		1
...	BZ 7911	Accelerator pedal taper pin	No. 00x 1/2"	1
...	BZ 24093	Foot rest		1
...	BZ 24091	Foot rest cap		1
...	GO 18345	Foot rest bolt	7/16-14x2 1/2" step	1
...	BZ 25327	Shaft		1
...	BZ 60874	Shaft lever—long		1
...	BZ 25364	Shaft lever—short		1
...	BZ 7911	Shaft lever taper pins	No. 00x 1/2"	2
...	BZ 23699	Shaft silencing spring		1
...	BZ 29425	Pedal to carburetor rod		1
...	BZ 5771	Pedal to carburetor rod yoke	3/16"x32	1
...	BZ 12799	Pedal to carburetor rod nut	No. 10-32x 1/2"	1
...	BZ 5825	Pedal to carburetor rod clevis pin	3/16"x11/16"	2
...	BZ 29120	MIXTURE CONTROL ASSEMBLY		1
...	BZ 29180	Mixture control wire tube clip		1

When ordering give letter prefix with symbol number—Example: CX 2890.

HEAT CONTROL

Illus. No.	Part No.	Description	Specifications	No. Req.
		DIAL ASSEMBLY		
...	RZ 79754	Operating lever		1
...	RZ 29185	Operating lever spring		1
...	RZ 29186	Operating lever bracket		1
...	RZ 7343	Operating lever bracket clevis pin	$\frac{1}{2}$ "x1.0-16"	1
...	RZ 18448	Operating lever bracket rivet	No. 9 $\frac{1}{2}$ " Tubular	2
...	RZ 79469	Operating rod	$\frac{1}{2}$ "x28x7-32"	1
...	RM 794	Operating rod nut	$\frac{1}{2}$ "x28	1
...	GZ 70954	Operating rod clevis	$\frac{1}{2}$ "x3	1
...	RZ 8682	Operating rod clevis pin	$\frac{1}{2}$ "x3	2
...	RZ 70956	Clevis pin	$\frac{1}{2}$ "x9-32"	1

SPARK AND THROTTLE CONTROL

SPARK CONTROL				
...	GZ 39190	Cross tube		1
...	GZ 37596	Cross tube lever—R. H.		1
...	RZ 13532	Cross tube lever—L. H.		1
...	RZ 14446	Cross tube lever clamp bolt	$\frac{1}{2}$ "x28x7 special	1
...	RM 794	Cross tube lever clamp bolt nut	$\frac{1}{2}$ "x28x7-32	1
...	RZ 23161	Lever to distributor link		1
...	RZ 12799	Lever to distributor link nut	No. 10-32	2
...	RZ 13527	Cross tube bracket		1
...	RM 219	Cross tube bracket bolt	5-16"x18 $\frac{1}{2}$ "	1
...	RZ 29459	Steering gear to control shaft rod		1
...	12799	Steering gear to control shaft rod nut	No. 10-32	1
...	RZ 3771	Steering gear to control shaft rod yoke	3-16"x32	1
...	RZ 5825	Steering gear to control shaft rod clevis pin	3-16"x31-16"	2

THROTTLE CONTROL

...	RZ 39193	Throttle control rod		1
...	RM 794	Throttle control rod nut	$\frac{1}{2}$ "x28x7-32"	1
...	RZ 5774	Throttle control rod clevis	$\frac{1}{2}$ "x28 thread	1
...	RZ 8682	Throttle control rod pin	$\frac{1}{2}$ "x1"	1
...	RZ 29460	Throttle control transmission		1
...	RZ 29461	Throttle control rod collar		1
...	RZ 12642	Throttle control spring		1
...	RZ 25345	Throttle control spring clip		1

BRAKE CONTROL

BRAKE RODS

...	RZ 29262	Front brake operating rod	27 $\frac{1}{2}$ " long	2
...	BR 611	Front brake operating rod nut	5-16"x28x17-64"	4
...	RZ 8683	Front brake operating rod clevis pin	5-16"x1"	2
...	CZ 29266	Front brake intermediate rod	40 $\frac{1}{2}$ " long	2
...	RZ 8683	Front brake intermediate rod clevis pin	5-16"x1"	4
...	RZ 29267	Foot brake pedal rod	14 $\frac{1}{2}$ " long	1
...	RZ 5252	Foot brake pedal rod yoke	$\frac{1}{2}$ " S. A. E. adjustable	1
...	RZ 62	Foot brake pedal rod nut	$\frac{1}{2}$ "x24x21-64"	2
...	DY 3212	Foot brake pedal rod clevis pin	$\frac{1}{2}$ "x1-5-32"	1
...	RZ 29269	Rear brake intermediate rod 114 $\frac{1}{2}$ " wheelbase	15 $\frac{1}{2}$ " long	2
...	RZ 30110	Rear brake intermediate rod 118 $\frac{1}{2}$ " wheelbase	19 $\frac{1}{2}$ " long	2
...	RZ 8683	Rear brake intermediate rod clevis pin	5-16"x1"	2
...	RZ 29270	Rear brake operating rod 122 $\frac{1}{2}$ " wheelbase	21 $\frac{1}{2}$ " long	2
...	RZ 30111	Rear brake operating rod 118 $\frac{1}{2}$ " wheelbase	19 $\frac{1}{2}$ " long	2
...	BR 611	Rear brake operating rod nut	5-16"x28x17-64"	4
...	RZ 29271	Hand brake operating rod	27 $\frac{1}{2}$ " long	1
...	BR 611	Hand brake operating rod nut	5-16"x28x17-64"	2
...	RZ 29268	Equalizer bar to play link rod	19 $\frac{1}{2}$ " long	1
...	BR 611	Equalizer bar to play link rod nut	5-16"x28x17-64"	1
...	DZ 3777	Equalizer bar to play link rod yoke	3-16" S. A. E. adjustable	1
...	RZ 8683	Equalizer bar to play link clevis pin	5-16"x1"	1

BRAKE LEVERS AND SHAFTS

...	RZ 29280	Front brake cross shaft end lever		1
...	RZ 29281	Rear brake equalizer bar lever		2
...	RZ 29282	Rear brake cross shaft end lever		2
...	RZ 29286	Rear brake cross shaft center lever		1
...	RZ 29243	Rear brake lever spring		4
...	GZ 7115	Bolt	$\frac{1}{2}$ "x16x $\frac{1}{2}$ "	3
...	RM 119	Bolt nut	$\frac{1}{2}$ "x16 $\frac{1}{2}$ "	3
...	RZ 30280	Rear brake idler lever		4
...	RZ 70115	Rear brake idler lever clevis pin	5-16"x1-5-32"	2
...	RZ 13556	Rear brake idler lever spring		2

When ordering give letter prefix with symbol number—Example: CX 28840.

BRAKE LEVERS AND SHAFTS (Continued)

Illus. No.	Part No.	Description	Specifications	Qty. Req.
...	CZ 29279	Front brake cross shaft	35-5/16" long	1
...	GZ 636	Front brake cross shaft key	Woodruff No. 11	1
...	CZ 29284	Rear brake cross shaft	35-5/16" long	1
...	GZ 636	Rear brake cross shaft key	Woodruff No. 11	1
...	BZ 29277	Brake cross shaft bearing		4
...	BZ 29278	Brake cross shaft bearing retainer		4
...	BZ 29278	Brake cross shaft bearing cage		4
...	BZ 4961	Brake cross shaft bearing cage allow	1/2" street allow.	4
...	BZ 21797	Brake cross shaft bearing cage oil cup		8
...	BR 1308	Brake cross shaft bearing cage bolt	1/2"-16x1 1/2"	8
...	BM 110	Brake cross shaft bearing cage bolt nut	1/2"-16x1 1/2"	8
...	BZ 29263	Front brake idler lever=L, H.		1
...	BZ 29264	Front brake idler lever=L, H.		1
...	BZ 29265	Front brake idler lever pivot		2
...	BZ 124	Front brake idler lever pivot nut	1/2"-24x13-32" castle	2

MISCELLANEOUS

...	BZ 29289	Hand brake operating rod slide yoke		1
...	BZ 70120	Clevis pin	5-16"x1-1-32"	1
...	BZ 6449	Plain washer	21-64"x1"x5-64"	1
...	BZ 29287	Brake lever play link		1
...	BY 3212	Brake lever play link clevis pin	1/2"-1-5/32"	1
...	BZ 6483	Brake lever play link clevis pin	5-16"x1"	1
...	BZ 29282	Brake equalizer bar		1
...	BZ 29283	Brake equalizer bar pivot		1
...	BZ 62	Brake equalizer bar pivot nut	1/2"-24x21-64"	1
...	BZ 29272	Front brake release spring		1
...	BZ 29273	Front brake release spring clip		1
...	BZ 29275	Rear brake release spring (127 1/2" wheelbase)		2
...	BZ 30125	Hand brake and rear brake release spring		1
...	BZ 30278	Hand brake lever spring clip		4
...	BZ 29264	Brake control lever ball nut		1

UNIVERSAL JOINTS AND PROPELLER SHAFT

...	CZ 25440	REAR UNIVERSAL JOINT AND PROPELLER SHAFT ASSEMBLY (Includes 25293, also 2540 to 25299 inclusive) (127" wheelbase)		1
...	CZ 30638	REAR UNIVERSAL JOINT AND PROPELLER SHAFT ASSEMBLY (118" wheelbase)		1
...	CZ 25293	Propeller shaft (127" wheelbase)		1
...	CZ 30108	Propeller shaft (118" wheelbase)		1
...	BZ 20040	FRONT UNIVERSAL JOINT ASSEMBLY (Includes 9905, also 18106 to 20145 inclusive)		1
...	2 GZ 9905	Companion flange-front		1
...	1 BZ 9906	Companion flange-rear		1
...	4 BZ 18106	Companion flange bolt		12
...	5 BR 611	Companion flange bolt nut		12
...	6 BZ 23273	Companion flange bolt nut lock		12
...	7 BZ 7840	Flange yoke		8
...	8 BZ 1067	Bushing		8
...	9 BZ 1065	Bushing lock ring		8
...	10 BZ 7824	Cross		2
...	11 BZ 7843	Inside casing		2
...	12 BZ 7833	Outside casing		2
...	13 BZ 7835	Outside casing packing		2
...	14 BZ 7829	Inside casing plug		2
...	15 BZ 20146	Outside casing spring		2
...	16 BZ 20147	Outside casing spring retainer		2
...	17 BZ 18052	Outside casing spring retainer bolt		4
...	18 BZ 12799	Outside casing spring retainer ball nut		4
...	19 BZ 7834	Dust cap		1
...	20 BZ 7831	Dust cap felt washer		1
...	21 BZ 7832	Dust cap felt washer retaining disc		1
...	22 BZ 20145	Sleeve yoke		1

When ordering give letter prefix with symbol number—Example: CX 28960.



STEERING GEAR

Illus. No.	Part No.	Description	Specifications	No. Req.
...	CZ 30305	STEERING GEAR COMPLETE		1
...	CZ 30491	CONTROL ASSEMBLY	118' Cars, 12269 to 26570; 127' Cars, 81350 to 81352	1
...	CZ 30732	CONTROL ASSEMBLY	118' Cars, 26570 and upward; 127' Cars, 81350 and upward	1
1	BZ 30490	CASE AND GEARS COMPLETE		1
1	BZ 30504	CASE ASSEMBLY		1
2	BM 120	Case pipe plug	1/2" extension head	1
3	BZ 29737	Case adjusting stud		1
4	BZ 29740	Case eccentric adjusting sleeve		1
5	BZ 29744	Case eccentric adjusting sleeve lock ring		1
4	RZ 29743	Case lower bushing		1
9	BZ 70197	Case clamp bolt	7-16"-20x2 1/2"	1
10	BZ 29746	Case clamp bolt nut	7-16"-20x 1/2"	1
11	BZ 70194	Case stud		5
12	BZ 29739	Case eccentric stud		1
13	BZ 15574	Sector tube bracket		1
14	BZ 29742	Sector tube bracket gasket		1
15	BZ 18358	Sector tube bracket machine screw	1/2"-20x 1/2"	2
16	BZ 8162	Sector tube bracket bolt	1/2"-20x 1/2"	1
17	BZ 30515	Case cover		1
18	BZ 29745	Case cover gasket		1
...	BZ 29746	Case cover stud		3
...	BZ 70194	Case cover stud nut	7-16"-20	1
...	BZ 70196	Case cover stud pin washer	29 64 x 1 1/2 x 3/16" special	2
21	BZ 30514	Frame bracket		1
...	BZ 70140	Frame bracket bolt	1/2"-20x 1/2"	2
...	BZ 72	Frame bracket bolt nut	1/2"-20x 1/2"	2
22	BZ 29731	Main tube—lower	20x19 1/2" castile	1
23	BZ 35490	Main tube coupling		1
24	BZ 10127	Main tube coupling key—lower		1
25	CZ 70203	Main tube coupling body	5-16"-24x 1/2"	1
26	HW 411	Main tube coupling bolt nut	5-16"-24	4
27	BZ 29732	WORM		1
28	BZ 27841	Worm key		1
29	BZ 18102	Worm thrust bearing		1
...	BZ 30151	Worm thrust washer		1
30	BZ 29793	ROLLER TOOTH AND SHAFT ASSEMBLY		1
31	BZ 29749	Roller tooth shaft bushing		2
32	BZ 22641	Roller tooth shaft nut		1
33	BZ 20605	Roller tooth shaft nut lock		1
34	BZ 29750	Roller tooth shaft thrust washer		1
35	BZ 29748	Roller tooth shaft adjusting screw		1
36	BZ 70195	Roller tooth shaft adjusting screw lockwasher		1
36	BZ 70201	Roller tooth shaft adjusting screw nut	9-16"-18x7-32" hex.	1
37	BZ 29202	Roller tooth shaft arm (lever)		1
38	BZ 30516	Bearing adjusting sleeve		1
...	BZ 30565	Bearing adjusting sleeve screw		1
...	BZ 70278	Bearing adjusting sleeve screw lock nut		1
40	BZ 29241	Bearing adjusting sleeve packing		1
41	BZ 29753	Bearing adjusting sleeve packing plug		1
42	BZ 29747	Bearing adjusting sleeve bushing		1
43	BZ 24139	Bearing adjusting sleeve felt washer		1
44	CZ 30316	STEERING WHEEL ASSEMBLY		1
45	BZ 8394	Steering wheel key		1
46	BZ 30492	Main tube—upper 118' Cars, 12269 to 26570; 127' Cars, 80350 to 81350		1
...	BZ 30751	Main tube—upper 118' Cars, 26570 and upward; 127' Cars, 81350 and upward		1
47	BZ 26345	Main tube nut		1
48	BZ 4831	Main tube key coupling—upper		1
49	BZ 30502	Jacket tube 118' Cars, 12269 to 26570; 127' Cars, 80350 to 81350		1
...	BZ 30524	Jacket tube 118' Cars, 26570 and upward; 127' Cars, 81350 and upward		1
50	BZ 30503	Jacket tube bushing		1
51	BZ 79325	JACKET TUBE BRACKET Model 118"—all models; Model 127"—Sed. Sedan		1
51	BZ 79326	JACKET TUBE BRACKET Model 127"—S-Pass. Landaу Sedan, Victoria and T-Pass. Sedan		1
...	BZ 70139	No. 416 Nice ball bearing		1
...	BZ 79323	Bearing felt		1
...	BZ 79322	Bearing retainer		1
...	BZ 79324	Bearing retainer snap		1
...	BZ 79325	Bearing clamp		1
52	BZ 30499	STATIONARY TUBE ASSEMBLY 118' Cars, 12269 to 26570; 127' Cars, 80350 to 81350		1

When ordering give letter prefix with symbol number—Example: CX 20400.

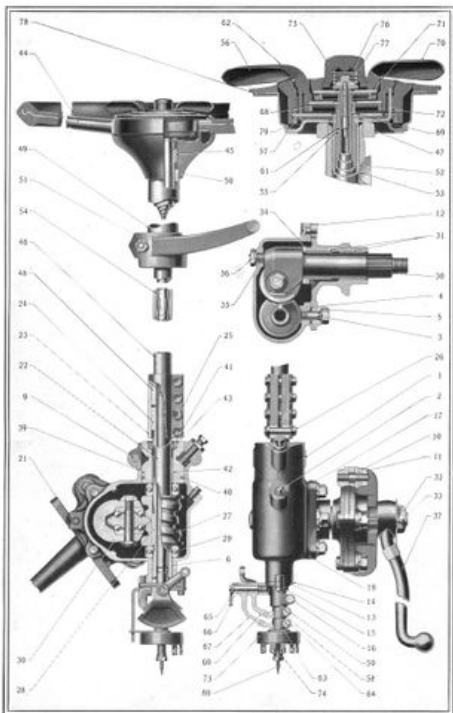

STEERING GEAR (Continued)

Illus. No.	Part No.	Description	Specifications	No. Req.
...	BZ 30755	STATIONARY TUBE ASSEMBLY (118' Cars, 26570 and upward; 127' Cars, 81592 and upward)		1
53	BZ 30489	Stationary tube silencer-upper		1
54	BZ 24770	Stationary tube silencer-lower		1
55	BZ 29754	Stationary tube washer-lower		1
60	CZ 30500	THROTTLE TUBE ASSEMBLY (118' Cars, 12269 to 26570; 127' Cars, 80350 to 81592)		1
...	CZ 30756	THROTTLE TUBE ASSEMBLY (118' Cars, 26570 and upward; 127' Cars, 81592 and upward)		1
56	BZ 30497	Throttle tube hand lever		1
57	BZ 30496	Throttle tube hand lever lock wire		1
58	BZ 10132	Throttle tube pinion		1
59	BZ 18137	Throttle tube pinion clamp screw	1/2"-20x1/2" 60L head	1
60	BZ 29539	Throttle sector		1
61	CZ 30501	SPARK TUBE ASSEMBLY (118' Cars, 12269 to 26570; 127' Cars, 80350 to 81592)		1
...	CZ 30757	SPARK TUBE ASSEMBLY (118' Cars, 26570 and upward; 127' Cars, 81592 and upward)		1
62	BZ 30498	Spark tube hand lever		1
63	BZ 10140	Spark tube pinion		1
64	BZ 18358	Spark tube pinion screw	5/16"-18x1 1/2"	1
65	BZ 29561	Sector stud		1
66	BZ 29562	Sector stud spring		1
67	BZ 29560	Spark sector		1
68	BZ 62960	Lock ring		1
69	CZ 30514	LIGHT TUBE ASSEMBLY (118' Cars, 12269 to 26570; 127' Cars, 80350 to 81592)		1
...	CZ 30760	LIGHT TUBE ASSEMBLY (118' Cars, 26570 and upward; 127' Cars, 81592 and upward)		1
70	BZ 30507	Light control lever		1
71	BZ 30508	Light control lever lock wire		1
72	BZ 20523	Control cup friction band		1
73	BZ 30308	Light control switch-lower		1
...	BZ 30539	Light control switch anchor		1
74	BZ 30590	Clamp nut light tube-lower		1
75	BZ 30599	HORN BUTTON		1
76	BZ 42088	Horn button contact washer		1
77	BZ 20513	Horn button spring		1
78	BZ 30217	Stationary tube cap		1
79	BZ 30227	Stationary tube cap lock wire		1
80	BZ 30540	Horn wire assembly		1

DRAG LINK

...	CZ 28978	DRAG LINK ASSEMBLY		1
...	CZ 28978	Drag link		1
...	BZ 23740	Ball seat		4
...	BZ 23739	Plug	1-1/2-16-18 thread	2
...	BZ 23738	Spring		2
...	BZ 21707	Oil cup		1
...	BZ 9044	Front boot		1
...	BZ 22146	Rear boot		1

FENDERS

...	A 78432	Front fender—R. H.		1
...	A 78433	Front fender—L. H.		1
...	A 80942	Front fender—R. H. (Pocket Type)		1
...	A 80943	Front fender—L. H. (Pocket Type)		1
...	A 78428	Rear fender—R. H. (118' Sedan and Coach)		1
...	A 78429	Rear fender—L. H. (118' Sedan and Coach)		1
...	A 78913	Rear fender—R. H. (127' 5-Passenger Landau Sedan and 7-Passenger Sedan)		1
...	A 78914	Rear fender—L. H. (127' 5-Passenger Landau Sedan and 7-Passenger Sedan)		1
...	A 79012	Rear fender—R. H. (127' Victoria)		1
...	A 79013	Rear fender—L. H. (127' Victoria)		1
...	A 79274	Rear fender—R. H. (127' Standard Sedan)		1
...	A 79275	Rear fender—L. H. (127' Standard Sedan)		1
...	A 79435	Rear fender—R. H. (118' Coupe)		1
...	A 79436	Rear fender—L. H. (118' Coupe)		1
...	BM 304	Bolt—Front fender	3/8"-16x1"	6
...	BM 110	Nut—Front fender bolt	3/8"-16x1"	6
...	BM 219	Bolt—Front fender	5/16"-18x1 1/2"	2
...	BO 18447	Screw—Front and rear fender	No. 10-32x1 1/2" Rd. Hd.	22
...	BZ 12799	Nut—Front and rear fender screw	No. 10-32x1 1/2"	22
...	GZ 10214	Bolt—Rear fender	3/8"-16x1 1/2"	6
...	BO 23410	Clip—Rear fender		14
...	BZ 12735	Screw—Rear fender clip		14
...	GO 23883	Plate—Rear fender		4

When ordering give letter prefix with symbol number—Example: CX 28960.

RUNNING BOARD AND RADIATOR SPLASH GUARDS

Illus. No.	Part No.	Description	Specifications	No. Req.
...	A 78662	Running board splash guard—R. H. (127")		1
...	A 78663	Running board splash guard—L. H. (127")		1
...	A 78664	Running board splash guard—R. H. (118")		1
...	A 78665	Running board splash guard—L. H. (118")		1
...	BO 12120	Square nut	$\frac{1}{2}$ "-20x $\frac{1}{2}$ "	4
...	BO 70048	Machine screw	$\frac{1}{2}$ "-20x1"	4
...	A 78631	Radiator splash guard		1
...	GO 22949	Radiator splash guard shim		1

REAR DUST SHIELD ASSEMBLY

...	A 79402	REAR DUST SHIELD ASSEMBLY (118" and 127")		1
...	A 80059	REAR DUST SHIELD ASSEMBLY (Standard Sedan and Landau with trunk)		1
...	BO 70129	Machine screw	$\frac{1}{2}$ "-20x $\frac{1}{2}$ "	4
...	A 79817	Rear dust shield sub panel (127" Standard Sedan only)		1
...	A 79324	Rear dust shield sub panel (Landau Sedan)		1

MOTOR SPLASH GUARDS

...	A 30275	Motor splash guard—front		1
...	A 30276	Motor splash guard—R. H.		1
...	A 30277	Motor splash guard—L. H.		1
...	G Y 353	Screw—front motor splash guard	$\frac{1}{2}$ "-20x $\frac{1}{2}$ "	4
...	G Y 3520	Screw—splash guard—R. H. and L. H.	$\frac{3}{16}$ "-18x $\frac{1}{2}$ "	7
...	BO 12126	Screw—Motor splash guard	No. 10-32x $\frac{1}{2}$ "	16
...	BZ 12799	Nut—Motor splash guard screw	No. 10-32x $\frac{1}{2}$ "	16

RUNNING BOARD

...	CZ 78651	RUNNING BOARD ASSEMBLY (118")		2
...	CZ 78658	RUNNING BOARD ASSEMBLY (127")		2
...	BO 18447	Screw—nut and head—running board	No. 10-32x $\frac{1}{2}$ "	32
...	BZ 12799	Nut—running board screw	No. 10-32x $\frac{1}{2}$ "	32
...	CZ 78709	Outer moulding (118")		2
...	CZ 78710	End moulding (118" and 127")		4
...	CZ 78711	Inner moulding (118")		2
...	CZ 78713	Outer moulding (127")		2
...	CZ 78714	Inner moulding (127")		2
...	BZ 18102	Rivet—split	$9/64$ "x $\frac{1}{2}$ "	80
...	CZ 78706	Running board covering (118")		2
...	CZ 78712	Running board covering (127")		2

TIRE CARRIER (Rear Type)

All models except Roadster

...	CZ 79151	TIRE CARRIER ASSEMBLY		1
...	GO 18234	Bolt	$7/16$ "-20x1"	5
...	BZ 12401	Nut	$7/16$ "-20x $\frac{1}{2}$ "	1
...	BZ 70148	Acorn nut	$7/16$ "-20x $\frac{1}{2}$ "	4
...	BZ 28105	Spare tire arm		2
...	BZ 12290	Nut	$\frac{1}{2}$ "-16x21-32"	2
...	BZ 29162	Clamp		1
...	BZ 29163	Clamp stud		1
...	BZ 41434	Clamp stud nut		1

(Roadster)

...	BZ 80329	TIRE CARRIER ASSEMBLY		1
...	BZ 80331	Tire carrier arm—R. H.		1
...	BZ 80332	Tire carrier arm—L. H.		1

TIRE CARRIER (Fender Type)

...	BZ 80056	Tire carrier arm—R. H.		1
...	BZ 80057	Tire carrier arm—L. H.		1
...	BZ 70115	Tire carrier arm nut		2
...	BZ 80065	Tire carrier arm grommet		2
...	BZ 80059	Tire carrier bracket—R. H.		1
...	BZ 80060	Tire carrier bracket—L. H.		1
...	GT 9824	Tire carrier bracket bolt	$\frac{1}{2}$ "-16x $\frac{1}{2}$ "	1
...	BZ 70404	Tire carrier bracket bolt and nut	$7/16$ "-14x $\frac{1}{2}$ "	4

When ordering give letter prefix with symbol number—Example: CX 28960.

TIRE CARRIER (Fender Type) (Continued)

Illus. No.	Part No.	Description	Specifications	No. Req.
...	BZ 80602	Tire carrier stay rod		2
...	BZ 80146	Tire carrier stay rod nut		2
...	BZ 70402	Tire carrier stay rod check nut	$\frac{1}{2}$ "-20	2
...	BZ 80603	Tire carrier clamp		2
...	BZ 80603	Tire carrier clamp spacer		2
...	BZ 80149	Tire carrier lock assembly		2
...	BZ 80150	Tire carrier lock key		2
...	BZ 80147	Tire carrier lock bolt		2
...	BZ 80148	Tire carrier lock stirrup		2
...	BZ 18464	Tire carrier lock stirrup screw		4
...	BO 12120	Tire carrier lock stirrup screw nut		4

BONNET

...	A 78718	BONNET COMPLETE		1
...	A 79059	BONNET COMPLETE (127" Standard Sedan)		1
...	BO 12362	Handle		2
...	BZ 70326	Handle rivet—tubular	$\frac{7}{32}$ "x $\frac{1}{4}$ "	4
...	BO 25802	Bonnet lock catch		6
...	BZ 70326	Lock catch rivet—tubular	$\frac{7}{32}$ "x $\frac{1}{4}$ "	12

BONNET LOCK ASSEMBLY

...	BO 28916	BONNET LOCK ASSEMBLY		4
...	GO 18342	Machine screw	No. 10-32x $\frac{1}{2}$ " Rd. Hd.	8
...	BZ 12799	Nut	No. 10-32x $\frac{1}{2}$ "	8

HEAD LAMP TIE BAR

...	CZ 79101	Head lamp tie bar		1
...	BZ 79102	Head lamp bracket—R. H.		1
...	BZ 79103	Head lamp bracket—L. H.		1
...	BO 79001	Bolt	$\frac{7}{16}$ "-14x $\frac{1}{2}$ "	2
...	BZ 11557	Bolt	$\frac{1}{2}$ "-16x $\frac{1}{2}$ "	2
...	BZ 79104	Pedestal		2
...	BO 72531	Machine screw	$\frac{1}{2}$ "-20x $\frac{1}{2}$ "	2
...	BZ 79105	Pedestal base		2
...	BZ 79107	Pedestal base spring		2
...	GZ 4954	Clevis pin	$\frac{3}{8}$ "x $\frac{1}{2}$ "	2
...	BZ 79108	Licence bracket		2
...	BS 7435	Nut	No. 10-32x $\frac{1}{4}$ "	2
...	BO 70227	Screw	No. 10-32x $\frac{1}{4}$ "	2
...	BZ 73106	Pedestal plug		2

SIDE LAMP BRACKET

...	BO 89124	SIDE LAMP BAND ASSEMBLY		2
...	BO 80122	Side lamp bracket—R. H.		2
...	BO 80123	Side lamp bracket—L. H.		2
...	BO 80685	Bolt spacer—medium		2
...	BO 80686	Bolt spacer—short		2
...	BO 70186	Bolt—band to cowd		14
...	BO 12120	Nut—band to cowd bolt		14
...	BO 70543	Acorn nut—side lamp bracket		8

HEAD LAMP

(Phaeton, 5-Pass Landau Sedan, Victoria, 7-Pass Sedan)

...	BO 30109	HEAD LAMP COMPLETE		2
...	BO 30474	Spacer—lamp to bracket		2
...	BO 30372	Washer—lamp to bracket		2
...	BO 30473	Nut—lamp to bracket		2
...	BO 30364	DOOR ASSEMBLY (less lens)		2
...	BO 30659	Screw—door		2
...	BO 30660	Retainer—door screw		2
...	BO 30362	Lens		2
...	BO 30440	Gasket—lens		2
...	BO 30365	Spring—lens		2
...	BO 30443	REFLECTOR ASSEMBLY		2
...	BO 30371	CONNECTOR WIRES AND SOCKET ASSEMBLY		2

When ordering give letter prefix with symbol number—Example: CX 28905.

HEAD LAMP (Continued)

Illus. No.	Part No.	Description	Specifications	No. Req.
...	BO 70353	Focus screw		2
...	BO 30370	Packing—focus screw		2
...	BO 30357	Packing washer—focus screw		2
...	BO 30439	Spring—focus screw		2
...	BO 30369	Cam—focus screw		2
...	BO 30373	Cam pin (slotted head)		2
...	BO 30358	Spring—cam pin		2
...	BO 30354	Arm—cam		2
...	BO 30351	Terminal socket sleeve		2
...	BO 30350	Terminal socket		2
...	BO 30348	CONDUIT AND CAP ASSEMBLY		2
...	BO 70349	Not—conduit to radiator (127" Standard Sedan, 118" Coach, 118" Sedan, 118" Coupe)		2
...	BO 30312	HEAD LAMP COMPLETE		2
...	BO 30474	Space—lamp to bracket		2
...	BO 70372	Washer—lamp to bracket		2
...	BO 30475	Nut—lamp to bracket		2
...	BO 30395	DOOR ASSEMBLY (less lens)		2
...	BO 30059	Screw—door		2
...	BO 30067	Retainer—door screw		2
...	BO 30383	Lens		2
...	BO 30391	Gasket—lens		2
...	BO 30450	Spring—lens		2
...	BO 30447	REFLECTOR ASSEMBLY		2
...	BO 30271	CONNECTOR WIRES AND SOCKET ASSEMBLY		2
...	BO 70355	Focus screw		2
...	BO 30370	Packing—focus screw (felt)		2
...	BO 30357	Packing washer—focus screw		2
...	BO 30446	Spring—focus screw		2
...	BO 30369	Cam—focus screw		2
...	BO 30373	Cam pin—focus screw		2
...	BO 30358	Spring—cam pin		2
...	BO 30374	Arm—cam		2
...	BO 30351	Terminal		2

SIDE LAMPS

(Phaeton, 5-Pass. Landau Sedan, Victoria, 7-Pass. Sedan)

(Optional with 30662 and 30663)

...	BO 30310	SIDE LAMP COMPLETE—R. H. (external lug for attaching door)		1
...	BO 30311	SIDE LAMP COMPLETE—L. H. (external lug for attaching door)		1
...	BO 30410	DOOR ASSEMBLY (less lens)		2
...	BO 70363	Screw—door	No. 8-32 cone pt.	2
...	BO 30407	Lens		2
...	BO 30408	Gasket—lens		2
...	BO 30406	Spring—lens		2
...	BO 33398	Conduit—wire		2
...	BO 70369	Rubber ferrule	9/32"x 1/2"	2
...	BO 79785	Conduit body ferrule—nickel-plated		2
...	BO 30404	REFLECTOR ASSEMBLY		2
...	BO 30401	WIRE ASSEMBLY		2
(Phaeton, 5-Pass. Landau Sedan, Victoria, 7-Pass. Sedan)				
(Optional with 30310 and 30311)				
...	BO 30662	SIDE LAMP COMPLETE—R. H. (internal lug for attaching door)		1
...	BO 30663	SIDE LAMP COMPLETE—L. H. (internal lug for attaching door)		1
...	BO 30650	SIDE LAMP DOOR ASSEMBLY (less lens)		2
...	BO 70422	Side lamp door screw		2
...	BO 30652	Lens		2
...	BO 30408	Gasket—lens		2
...	BO 30406	Spring—lens		4
...	BO 30378	Conduit—wire		2
...	BO 30278	REFLECTOR ASSEMBLY		2
...	BO 30401	WIRE ASSEMBLY		2
(127" Standard Sedan, 118" Coach, 118" Sedan, 118" Coupe)				
(Optional with 30660 and 30661)				
...	BO 30313	SIDE LAMP COMPLETE—R. H. (external lug for attaching door)		1
...	BO 30314	SIDE LAMP COMPLETE—L. H. (external lug for attaching door)		1
...	BO 30426	DOOR ASSEMBLY (less lens)		2
...	BO 30424	Lens		2
...	BO 70363	Screw—door		4
...	BO 30425	Gasket—lens		2
...	BO 30406	Spring—lens		4
...	BO 30434	Conduit—wire		2
...	BO 70369	Rubber ferrule		2
...	BO 79785	Conduit body ferrule—nickel-plated		2

When ordering give letter prefix with symbol number—Example: CX 29662.

SIDE LAMPS (Continued)

Illus. No.	Part No.	Description	Specifications	No. Req.
---	BO 30423	REFLECTOR ASSEMBLY.....		2
---	BO 30418	WIRE ASSEMBLY.....		2
		(127" Standard Sedan, 118" Coach, Sedan, Coupe)		
		(Optional with 2013 and 20314)		
---	BO 30660	SIDE LAMP COMPLETE—R. H. (internal lug for attaching door).....		1
---	BO 30661	SIDE LAMP COMPLETE—L. H. (internal lug for attaching door).....		1
---	BO 30658	SIDE LAMP DOOR ASSEMBLY (less lens).....		2
---	BO 30659	Lens.....		2
---	BO 70425	Screws—lens.....		2
---	BO 30425	Gasket—lens.....		2
---	BO 30406	Spring—lens.....		4
---	BO 30434	Conduit—wires.....		2
---	BO 30423	REFLECTOR ASSEMBLY.....		2
---	BO 30418	WIRE ASSEMBLY.....		2

STOP AND TAIL LAMP

---	BZ 30315	STOP AND TAIL LAMP ASSEMBLY.....		1
---	BZ 70313	Nut.....	$\frac{1}{2}$ "-20x3/16"	2
---	BZ 30134	Terminal complete.....		1
---	BZ 30387	Door.....		1
---	BZ 30379	Door glass (red).....		1
---	BZ 70365	Screw (door).....		2
---	BZ 30378	Door glass gasket.....		1
---	BZ 30372	Licence lens.....		1
---	BZ 30381	Licence lens gasket.....		1
---	BZ 70001	Bulb.....	6-8 V.—15 C. P.	1
---	BZ 28066	Stop light switch.....		1
---	BZ 28066	Stop light switch bracket.....		1
---	BO 12124	Stop light switch to bracket screw.....	No. 10-32x $\frac{1}{2}$ "	2
---	BZ 12799	Stop light switch to bracket screw nut.....	No. 10-32x $\frac{1}{2}$ "	2
---	BZ 908	Stop light switch bracket to frame bolt.....	5/16"-18x $\frac{1}{2}$ "	1
---	BZ 122	Stop light switch bracket to frame bolt nut.....	5/16"-18x $\frac{1}{2}$ "	1
---	BZ 28581	Stop light switch spring.....		1
---	BZ 28072	Stop light switch spring clip.....		1
---	BZ 18049	Stop light switch spring clip screw.....	No. 10-32x $\frac{1}{2}$ "	1
---	BZ 12799	Stop light switch spring clip screw nut.....	No. 10-32x $\frac{1}{2}$ "	1

COWL VENTILATOR

---	A 76441	COVER ASSEMBLY.....		1
---	BO 18130	Clevis pin.....	12-64"x $\frac{1}{2}$ "	2
---	BO 77494	Spring.....		1
---	BO 77499	Adjusting screw.....		1
---	BO 76426	Adjusting screw spring.....		1
---	BZ 76429	Adjusting screw knob.....		1
---	BO 18116	Adjusting screw knob set screw.....	No. 8-32x3/16" headless	1
---	BO 78921	Adjusting screw arm.....		1
---	BO 18447	Adjusting screw arm set screw.....	No. 10-32x5/16" headless top point	1
---	BO 76425	Adjusting screw arm shaft.....		1
---	BO 78382	Adjusting screw bracket.....		1
---	BO 5728	Adjusting screw bracket screw.....	No. 10-32x7/16"	2
---	BO 12799	Adjusting screw bracket screw nut.....	No. 10-32x $\frac{1}{2}$ "	2

INSTRUMENTS AND MOUNTING

---	BO 79740	Instrument frame base.....		1
---	BO 79763	Instrument frame dial.....		1
---	BO 79758	Instrument frame glass.....		1
---	BO 79765	Instrument frame rim.....		1
---	BO 79601	Instrument frame anchor clip (upper).....		2
---	BO 79602	Instrument frame anchor clip (lower).....		2
---	BM 70388	Instrument frame anchor clip nut.....		4
---	BO 79619	INSTRUMENT LAMP SOCKET ASSEMBLY.....		2
---	BO 29133	Instrument lamp socket retainer spring.....		2
---	BO 29129	OIL PRESSURE GAUGE ASSEMBLY.....		1
---	BO 70124	Oil pressure gauge screw.....	No. 8-32x9/16"	2
---	BO 29130	AMMETER ASSEMBLY.....		1
---	BO 70124	Ammeter screw.....	No. 8-32x3/16"	1
---	BO 29135	Oil gauge and ammeter gasket.....		1
---	BO 79753	MOTOMETER (DASSE).....		3
---	BO 70124	Screw.....	No. 8-32x9/16" Rd. Hd.	2

When ordering give letter prefix with symbol number—Example: CX 20960.

ACCESSORIES

The units listed below are considered accessories and are serviced by the manufacturer. Parts and complete assemblies should be obtained direct from them or one of their dealers.

AIR CLEANER

AC Spark Plug Co., Flint, Michigan.

BATTERY

The Electric Storage Battery Co., Philadelphia, Pa.

ELECTRICAL EQUIPMENT

Starting Motor, Generator, Distributor, Ignition Coil and Switch—The Electric Auto-Lite Co., Toledo, Ohio.

GASOLINE GAUGE

King-Sealey Corporation, Ann Arbor, Michigan.

SPEEDOMETER

Stewart-Warner Speedometer Corp., Chicago, Ill.

VACUUM TANK

Stewart-Warner Speedometer Corp., Chicago, Ill.

WINDSHIELD CLEANER

Trico Products Corp., Buffalo, N. Y.

WIRING

Illus. No.	Part No.	Description	Specifications	No. Req.
...	BO 30484	Wire assembly—R. H. bright (head lamp to switch)	1
...	BO 30485	Wire assembly—L. H. bright (head lamp to switch)	1
...	BO 30482	Wire assembly—R. H. dim (head lamp to switch)	1
...	BO 30483	Wire assembly—L. H. dim (head lamp to switch)	1
...	BO 30486	Wire assembly—battery terminal on switch to junction block	1
...	BO 30487	Wire assembly—side lamp terminal on switch to junction block	1
...	BO 30488	Wire assembly—rear and instrument terminal to junction block	1
...	BO 30588	Wire assembly—junction block to side lamp junction	1
...	BO 28825	Wire assembly—junction block to tail lamp (127")	1
...	BO 30118	Wire assembly—junction block to tail lamp (118")	1
...	BO 79521	Wire assembly—junction block to instrument lamps	1
...	BO 30083	Wire assembly—junction block to horn	1
...	BO 28074	Wire assembly—junction block to stop light switch	1
...	BO 79526	Wire assembly—stop light switch to stop light (127")	1
...	BO 30120	Wire assembly—stop light switch to stop light (118")	1
...	BO 79623	Wire assembly—junction post to dome light (118" Coach, Sedan)	1
...	BO 79624	Wire assembly—junction post to dome light (118" Coupe)	1
...	BO 79664	Switch and wire assembly—dome light (127" Standard Sedan, 118" Coach, Coupe)	1
...	BO 79603	Switch and wire assembly—dome light (118" Sedan)	1
...	BO 79359	Wire assembly—switch to dome light (118" Coach, Sedan, Coupe)	1
...	BO 29992	Wire assembly—coil to ammeter	1
...	BO 30093	Wire assembly—coil to electroback	1
...	BO 29837	Wire assembly—ammeter to generator	1
...	BO 27811	Wire assembly—ammeter to starter	1
...	BM 30099	CABLE TUBE AND WIRE ASSEMBLY	1
...	BM 29932	Cable tube	1
...	BM 30091	Cable tube clip	1

When ordering give letter prefix with symbol number—Example: CK 28960.

WIRING (Continued)

Illus. No.	Part No.	Description	Specifications	No. Req.
...	BM 29986	Cable No. 1		1
...	BM 29987	Cable No. 2		1
...	BM 29988	Cable No. 3		1
...	BM 29989	Cable No. 4		1
...	BM 29990	Cable No. 5		1
...	BM 29991	Cable No. 6		1
...	BM 29829	Cable assembly—lead to distributor		1
...	BO 18168	High tension terminal clip		1
...	BM 18364	Spark plug terminal clip		1
...	BZ 40648	BATTERY GROUND CONNECTION		1
...	DM 219	Bolt—connection to frame		1
...	BZ 1222	Nut—connection to frame bolt		1
...	BZ 12843	Bolt—connection to battery		1
...	BZ 12844	Bolt nut—connection to battery		1
...	BZ 29836	BATTERY CABLE ASSEMBLY		1
...	BZ 29516	Battery cable loom		1
...	BO 18712	Rubber ferrule		2
...	GZ 3613	Rubber ferrule		5
...	BZ 6437	Rubber ferrule (on rear cross member)		2
...	BO 70142	Rubber ferrule (on dash)		1
...	BO 14911	Rubber ferrule (on dash)		4
...	BO 29444	Lighting clip—double		4
...	GO 11443	Battery cable clip		2
...	GO 13732	Lighting clip—small		4
...	GO 13733	Lighting clip—large		5
...	BO 62033	Generator wire clip		2
...	BO 30348	Cable and conduit—head lamp		2
...	BO 70349	Nut—conduit to radiator		2

TOOLS

...	BZ 30279	Starting crank		1
...	CZ 11074	Wheel puller		1
...	BZ 26557	Wheel puller screw		1
...	BZ 29178	Jack		1
...	BZ 29179	Jack extension		1
...	BZ 29180	Jack extension handle (rim nut wrench)		1
...	BZ 22692	Oil can		1
...	BZ 29620	Oil can holder		1
...	BM 22594	Spark plug and main bearing nut wrench		1
...	BM 23692	Eccentric adjusting wrench		1
...	BM 4672	Water pump stuffing nut wrench		1
...	BZ 22699	Hub cap wrench		1
...	BZ 29140	Wheel rim clamp nut wrench		1
...	BM 23389	Tappet adjusting wrench		1
...	BZ 28333	End wrench	No. 25 special	1

FLOOR MATS AND PADS

...	BO 79606	Front floor mat and pad assembly (118" Coach)		1
...	BO 79610	Front floor mat and pad assembly (127" 5-Passenger Landaulet, 7-Passenger Sedan)		1
...	BO 79632	Front floor mat and pad assembly (118" Sedan, Coupe)		1
...	BO 79616	Front floor mat and pad assembly (127" Victoria)		1
...	BO 79617	Front floor mat and pad assembly (127" Standard Sedan)		1
...	BO 80574	FRONT MAT AND PAD ASSEMBLY (118" Roadster)		1
...	BO 79406	Dash pad assembly (all Models)		1

ELECTROLOCK

(118" Cars, 12269 to 27212; 127" Cars, 803569 to 814533)

...	BZ 30009	ELECTROLOCK ASSEMBLY		1
...	BZ 30356	Bracket		1
...	BZ 18069	Machine screw	No. 10-32x 1 1/2"	1
...	BZ 12796	Nut	No. 10-32x 1 1/2"	1
...	BZ 30735	Electrolock cylinder		1
...	BO 27571	Key		1
...	BO 30249	Electrolock post		1
...	BZ 30730	118" Cars, 27212 and upward; 127" Cars, 814453 and upward		1
...	BZ 30734	ELECTROLOCK ASSEMBLY		1
...	BO 70440	Nut—Electrolock to instrument board		1
...	BO 70440	Washer—Electrolock to instrument board nut (brass)		1
...	BO 30735	Electrolock cylinder		1
...	BO 27571	Key		1
...	BO 30249	Electrolock post		1

When ordering give letter prefix with symbol number—Example: CX 28960.

HORN

NOTE: The horn assembly and the bracket are serviced by the Hudson Motor Car Co. All other parts are furnished by the E-A Laboratories Co., Brooklyn, N. Y.

Illus. No.	Part No.	Description	Specifications	No. Req.
...	BZ 30076	HORN AND BRACKET ASSEMBLY		1
...	BZ 30077	Bracket		1
...	BM 13073	Bracket stud	5/16"-18x1 1/2"	2
...	BZ 132	Bracket stud nut	5/16"-18x5/16"	2

STABILATOR

NOTE: The stabilator assembly is serviced by the John Warren Watson Co., Twenty-fourth and Locust Streets, Philadelphia, Pa. The following installation parts are manufactured and serviced by the Hudson Motor Car Co.

...	BZ 29504	Frame bracket—R. H.		1
...	BZ 29505	Frame bracket—L. H.		1
...	GY 635	Frame bracket bolt	7/16"-20x1 1/2"	4
...	BZ 232	Frame bracket bolt nut	7/16"-20x7/16"	2
...	BZ 29506	Front axle strap support		2
...	GO 1489	Front axle strap support nut	3/4"-11x9/16"	2
...	BZ 29507	Front axle strap support clamp		2

TRUNK RACK

...	CZ 30593	TRUNK RACK ASSEMBLY		1
...	BZ 30597	Trunk rack arm—R. H.		1
...	BZ 30598	Trunk rack arm—L. H.		1
...	BZ 30599	Trunk rack loop		1
...	BO 18470	Screw	No. 10-32x 1/2"	8
...	BZ 12739	Nut	No. 10-32x 1/2"	8
...	BZ 30595	Trunk rack bracket—R. H.		1
...	BZ 30596	Trunk rack bracket—L. H.		1
...	BZ 12735	Bolt	5/16"-18x1"	4
...	BZ 122	Nut	5/16"-18x5/16"	4
...	BZ 30594	Trunk rack frame		1
...	BZ 30600	Trunk rack pivot screw		4
...	BZ 12481	Trunk rack pivot screw nut	5/16"-24x5/16"	4
...	BO 26191	Trunk rack wing screw		2

RUMBLE SEAT STEPS

...	BZ 79842	Upper step		1
...	BZ 70381	Screw	F. H.—5/16"-18x1 1/2"	1
...	BZ 122	Nut	5/16"-18x5/16"	3
...	BZ 30600	Lower step		1
...	BZ 70238	Screw	F. H.—3/8"-16x1-13/16"	1
...	BZ 9606	Nut	3/8"-16	1
...	BZ 60076	Lower step bracket	3/8"-18x1 1/2"	1
...	BZ 7115	Bolt	Hex. Hd.—3/8"-16x1 1/2"	1
...	BZ 12310	Bolt	3/8"-16x1 1/2"	1
...	BZ 79791	Washer—step bolt angle		1
...	BZ 70047	Nut	3/8"-16	2
...	BZ 80292	Lower step arm		1
...	BZ 636	Key	Woodruff No. 11	1
...	BZ 30603	Lower step arm nut		1

FRONT AXLE—R. H. DRIVE

...	CX 28970	FRONT AXLE ASSEMBLY		1
...	BX 28968	Steering arm—R. H.		1
...	BX 28969	Steering arm—L. H.		1

FRAME—R. H. DRIVE

...	CF 30254	SIDE MEMBER ASSEMBLY—R. H. (127" cars)		1
...	CF 30257	SIDE MEMBER ASSEMBLY—R. H. (118" cars)		1

TRANSMISSION—R. H. DRIVE

...	CT 29166	TRANSMISSION ASSEMBLY	4-1/2 to 1 R. A. ratio	1
...	CT 28855	TRANSMISSION ASSEMBLY	4-5/11 to 1 R. A. ratio	1
...	GT 29713	Transmission case		1
...	BT 29368	Front bearing cap		1
...	BT 29378	CLUTCH THROWOUT YOKE ASSEMBLY		1

When ordering give letter prefix with symbol number—Example: CX 28968.

STEERING GEAR—R. H. DRIVE

Illus. No.	Part No.	Description	Specifications	No. Req.
...	CZ 30306	STEERING GEAR COMPLETE		1
...	CZ 30493	CASE AND GEAR ASSEMBLY		1
...	RZ 30506	CASE ASSEMBLY		1
...	CZ 29769	Steering column		1
...	RZ 29772	Worm		1
...	RZ 18102	Bearing	No. 6283	1
...	RZ 29770	Worm wheel		1
...	RZ 29771	Steering arm		1
...	RZ 29773	Frame bracket		1
...	RZ 29774	Housing cover		1
...	RZ 29774	Housing cover gasket		1
...	RZ 29782	Worm wheel bushing		2
...	RZ 29784	Worm wheel adjusting screw		1
...	RZ 30523	Nut	9/16" x 18	1
...	RZ 30527	Housing adjusting nut		1
...	RZ 30528	Adjusting nut packing		1
...	RZ 30529	Sector tube		1
...	RZ 30530	Throttle tube		1
...	RZ 30537	Spark tube		1
...	RZ 30536	Spark lever		1
...	RZ 30487	Throttle lever		1
...	RZ 30531	Insulator washer		1
...	RZ 30533	Horn button contact cup		1
...	RZ 30534	Horn button		1
...	RZ 29785	Worm shaft thrust washer		1
...	RZ 30453	Spark and throttle control name plate		1
...	RZ 29728	Bearing adjusting screw		1
...	RZ 29728	Spark control piston		1
...	RZ 28157	Horn button lock ring		1
...	RZ 28156	Horn button spring retainer		1
...	RZ 10149	Horn button spring		1
...	CZ 29402	Sector bracket tube assembly		1
...	RZ 30541	Horn wire assembly		1

DRAG LINK—R. H. DRIVE

...	CZ 28979	DRAG LINK ASSEMBLY		1
...	CZ 28977	Drag link		1

SPARK AND THROTTLE CONTROL—R. H. DRIVE

SPARK CONTROL				
...	RZ 29405	Steering gear to distributor rod		1
...	BM 794	Nut	$\frac{1}{2}$ "-28x7/32"	1
...	RZ 12799	Nut	No. 10-32x $\frac{1}{2}$ "	1
...	RZ 79150	Ball joint	No. 10-32 special	1
THROTTLE CONTROL				
...	RZ 29463	Steering gear to carburetor rod		1
...	BM 794	Nut	$\frac{1}{2}$ "-28x7/32"	1
...	RZ 13578	Yoke		1
...	RZ 29461	Collar		1
...	RZ 29460	Transmission		1
...	RZ 13579	Clevis pin	3/16" x 1-1/8" 14'	1
...	RZ 13542	Strap		1
ACCELERATOR				
...	RZ 29812	Pedal		1
...	RZ 7911	Pedal taper pin	No. 00x $\frac{1}{2}$ "	1
...	RZ 30194	Shaft		1
...	RZ 30191	Spring		1
...	RZ 23164	Lever-shaft		1
...	RZ 60574	Lever-shaft		1
...	RZ 7911	Lever taper pin	No. 00x $\frac{1}{2}$ "	2
...	RZ 29455	Pedal to carburetor rod		1
...	RZ 5771	Pedal to carburetor rod yoke	3/16" x 3/2"	1
...	RZ 12799	Pedal to carburetor rod nut	No. 10-32x $\frac{1}{2}$ "	1
...	RZ 5825	Pedal to carburetor rod clevis pin	3/16" x 1 1/8"	2

HAND BRAKE LEVER—R. H. DRIVE

...	GS 29066	HAND BRAKE LEVER ASSEMBLY		1
...	BS 29065	Hand brake lever		1

When ordering give letter prefix with symbol number—Example: CX 28960.

PEDAL CONTROL—R. H. DRIVE

Illus. No.	Part No.	Description	Specifications	No. Req.
.....	GZ 29376	PEDAL CONTROL ASSEMBLY		1
.....	GZ 29391	Brake pedal		1
.....	BX 18361	Brake pedal set screw	$\frac{1}{2}$ "-16x1 $\frac{1}{2}$ "	1
.....	BZ 5402	Brake pedal set screw nut	$\frac{1}{2}$ "-16x1 $\frac{1}{2}$ "	1
.....	BZ 3015	Brake pedal taper pin	No. 2x1 $\frac{1}{2}$ "	1
.....	BZ 115	Brake pedal key	Woodruff No. 9	1
.....	GZ 29763	Brake pedal lever		1
.....	BZ 3015	Brake pedal lever taper pin	No. 2x1 $\frac{1}{2}$ "	1
.....	BZ 115	Brake pedal lever key	Woodruff No. 9	1
.....	GZ 29294	Clutch pedal		1
.....	BZ 25447	Clutch pedal bushing		1
.....	GZ 29299	Pedal shaft		1
.....	BZ 24532	Pedal pad		2
.....	BR 1308	Pedal pad bolt	$\frac{1}{2}$ "-16x $\frac{1}{2}$ "	2
.....	GZ 29295	Bracket		1
.....	BR 1308	Bracket bolt	$\frac{1}{2}$ "-16x1 $\frac{1}{2}$ "	2
.....	GZ 24558	Bracket bushing		2
.....	BZ 29544	Clutch pedal link		1
.....	BZ 62	Clutch pedal link nut	$\frac{1}{2}$ "-24	1
.....	BY 3212	Clutch pedal link clevis pin	$\frac{1}{2}$ "x1-3 32"	1
.....	BZ 29540	Clutch pedal adjustable link		1
.....	BY 3212	Clutch pedal adjustable link clevis pin	$\frac{1}{2}$ "x1-3 32"	1

BRAKE CONTROL—R. H. DRIVE

.....	BZ 29292	Hand brake operating rod		1
.....	BR 611	Hand brake operating rod nut	5 16"-24x17 64"	2
.....	BZ 29762	Foot brake operating rod		1
.....	BZ 62	Foot brake operating rod nut	$\frac{1}{2}$ "-24x22 64"	1
.....	BZ 5282	Foot brake operating rod yoke		1
.....	BY 3212	Foot brake operating rod clevis pin	$\frac{1}{2}$ "x1-5 32"	2
.....	BZ 29383	Brake front cross shaft		1
.....	GZ 636	Brake front cross shaft key	Woodruff No. 11	3
.....	BZ 29384	Brake rear cross shaft		1
.....	GZ 636	Brake rear cross shaft key	Woodruff No. 11	3

RUBBER MATS AND FELT PADS—R. H. DRIVE

.....	BO 79609	FRONT MAT AND PAD ASSEMBLY (118" Coach)		1
.....	BO 79611	FRONT MAT AND PAD ASSEMBLY (5-Pass. Landau Sedan and 7-Pass. Sedan)		1
.....	BO 79613	FRONT MAT AND PAD ASSEMBLY (118" Sedan, 118" Coupe)		1
.....	BO 79618	FRONT MAT AND PAD ASSEMBLY (121" Std. Sedan)		1
.....	BO 80575	FRONT MAT AND PAD ASSEMBLY (118" Roadster)		1

When ordering give letter prefix with symbol number—Example: CX 28905.

Spears-Hines Printing Co.
Detroit 6-21-28

Factory Date 10th May, 1938.

Eng. Change No. 28713 - Plan Inst. 1245 - Subject - Electrolock.

Starting with Hudson Model "O" Car No. 814453, Model "S" No. 27212, and Essex Car No. 811410, new type Electrolocks are being used on all Hudson & Essex Cars.

The following symbols are affected:-

BO 30730 - Electrolock Assembly	Supersedes 30671 - BO 30089
BO 63202 - Electrolock Assy.	" 63186 - BO 62687
B2 30356 - Electrolock Clamp & Mtg.Brkt. Assy.	Discontinued.

Old and new style Electrolocks are interchangeable and new type only will be supplied by Service when stock of old is exhausted.

Service will continue to supply Clamp and Bracket Assembly for previous type cars.

TIMAIN FRONT BEARINGS

415 412A 315 312

REAR 3720 377

3196 3120 439T 432

458T 454

NEW DEPARTURE THRUST BEARING
0210

TRANSMISSION

NO 1308 + NO 1204

STEERING NO 6283