

MODEL KB-3

G.V.W. RATING 6,650 POUNDS

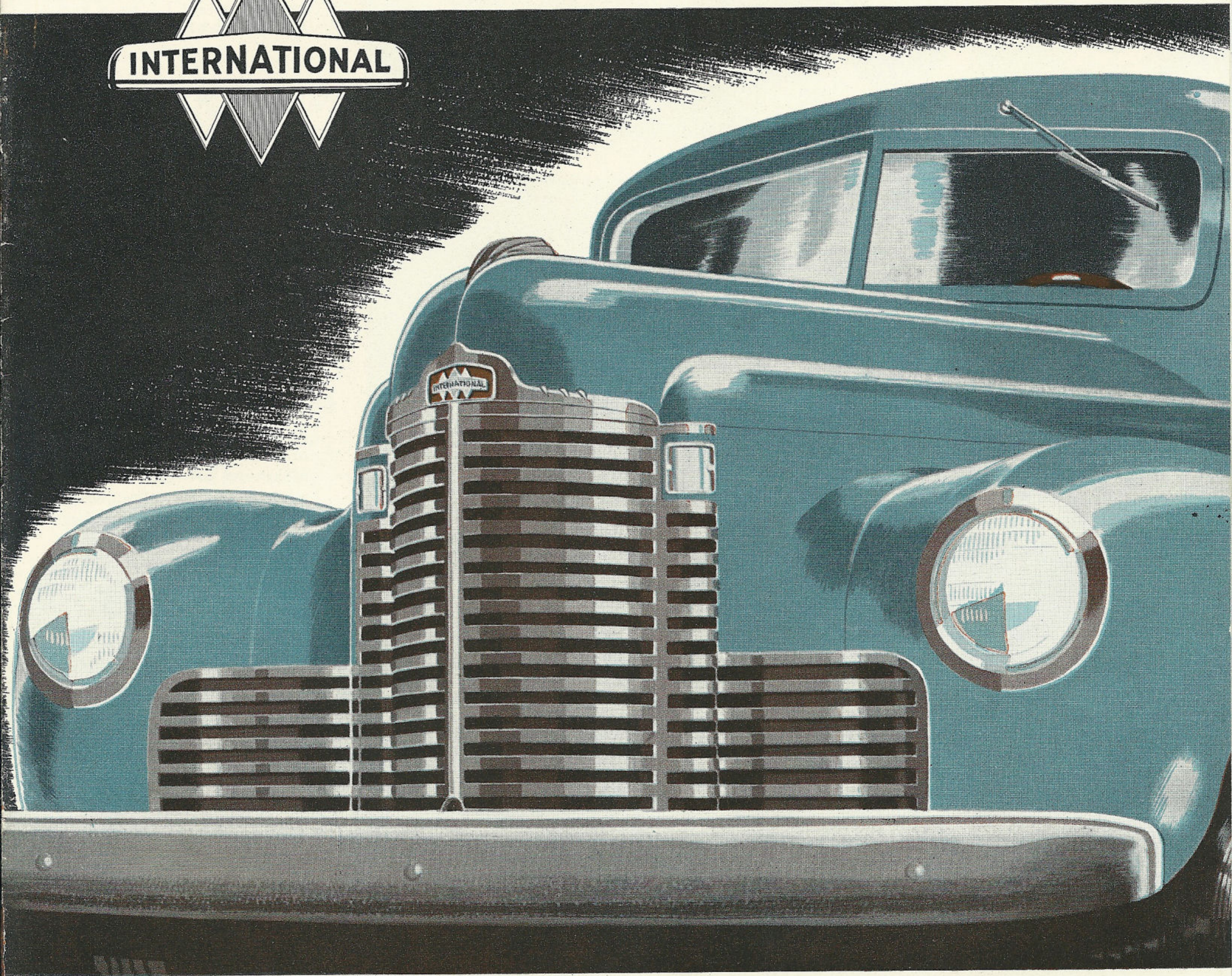

INTERNATIONAL

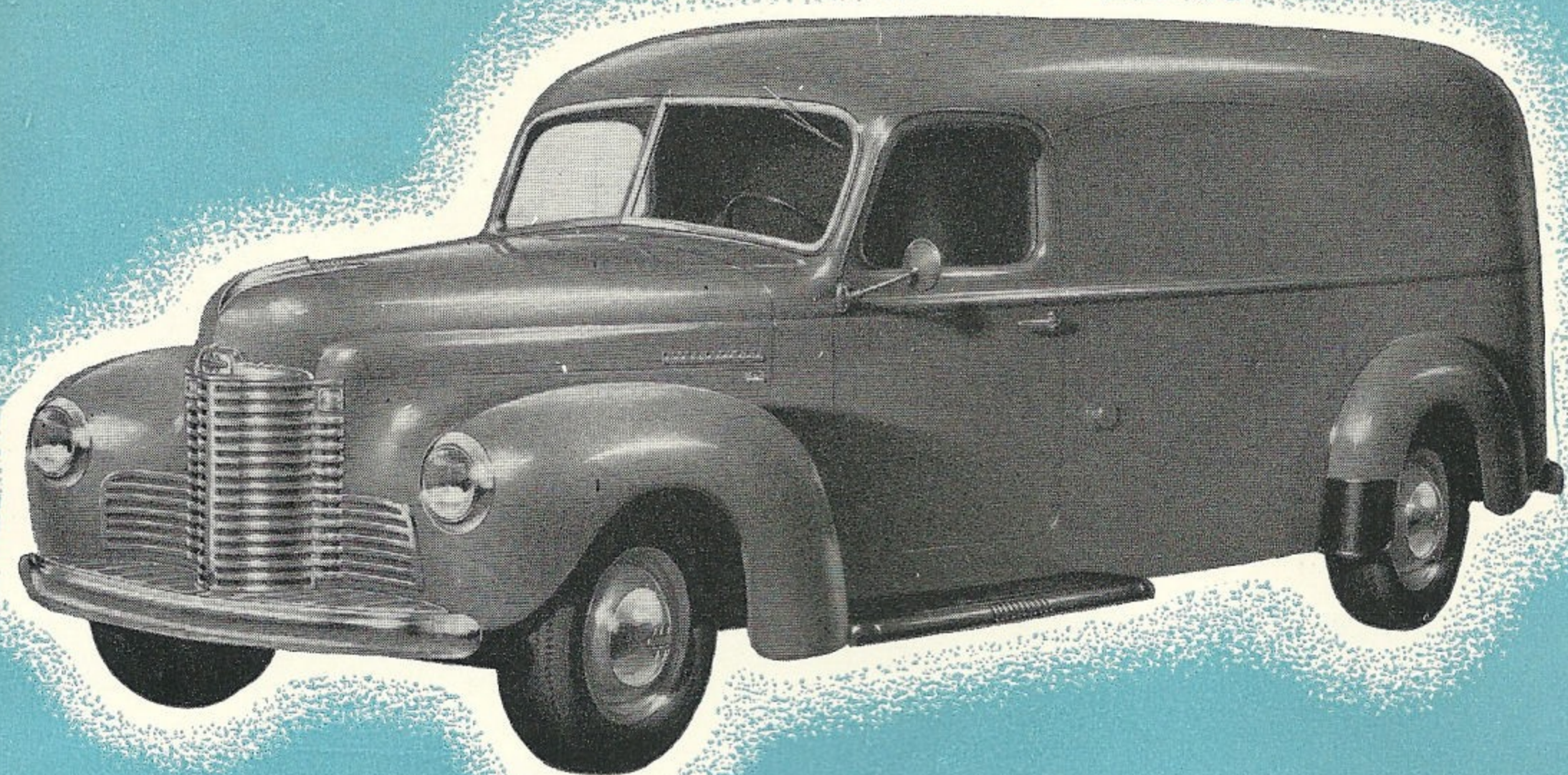

Handsome, large-capacity International streamlined deluxe panel bodies are rigidly constructed for safety and long life. The trim, symmetrical lines are further enhanced by the pressed-in belt and panel moldings. The panel body has a capacity of 171 cubic feet and measures 109 $\frac{3}{8}$ inches long at the floor, 46 $\frac{3}{8}$ inches between wheel housings and 56 inches high.

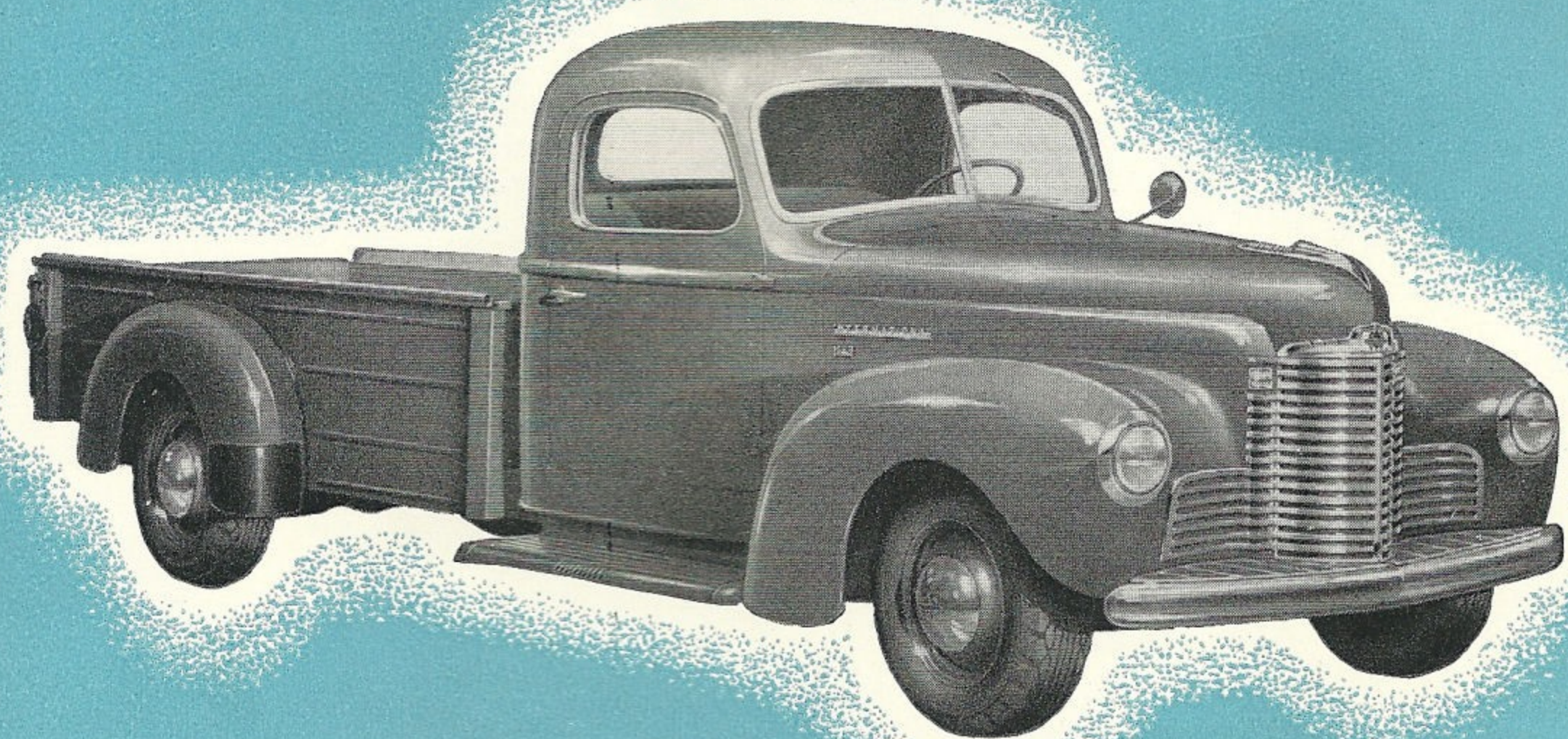

Pickup bodies have exceptionally large load capacities. The lines of the long all-steel drop-skirt bodies blend with the graceful contours of the grille head, cowl and cab, forming a light-duty transportation unit of distinctive appearance and maximum utility. Loading space is 102 inches long, 48 $\frac{1}{2}$ inches wide and 17 inches high at the top of the 4-inch-wide flareboards.

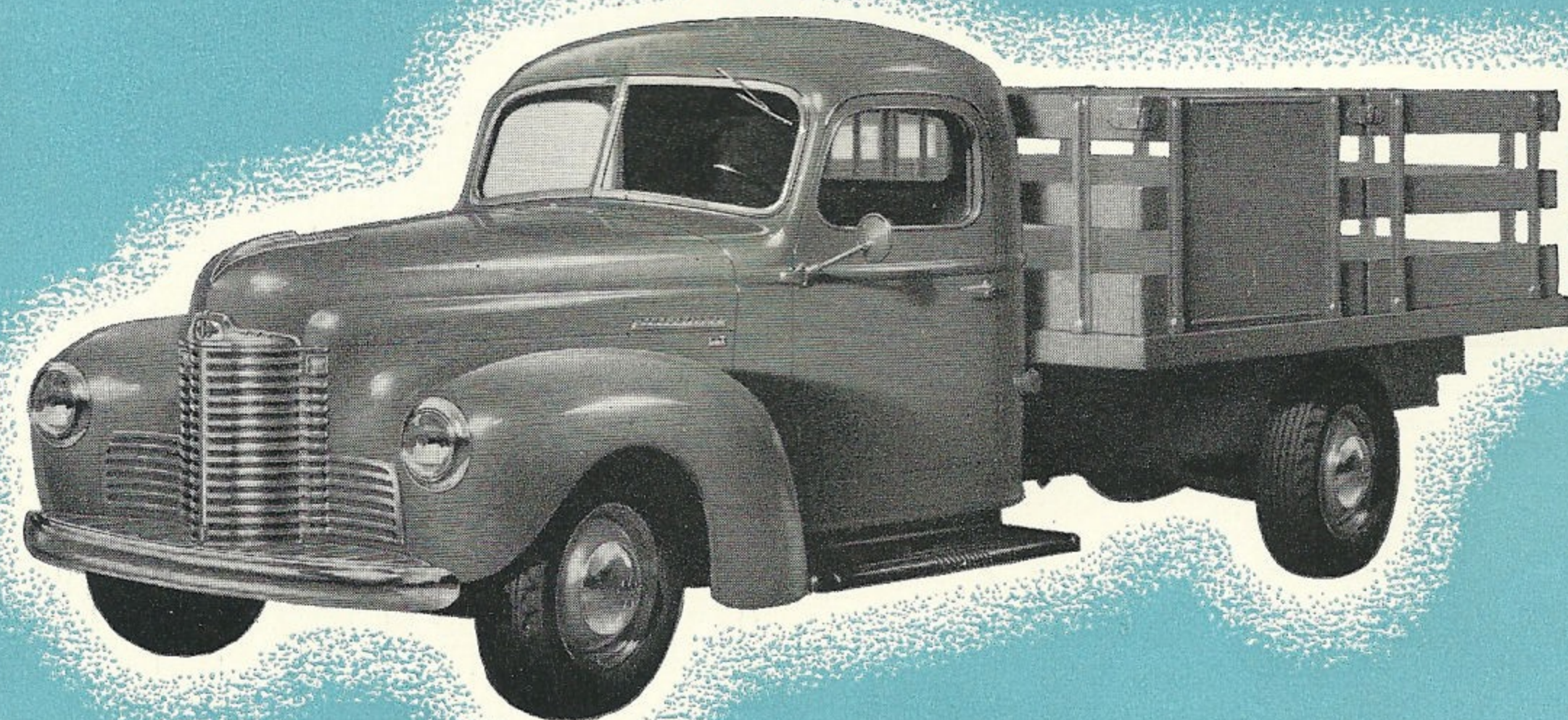

An 8-foot, light-duty, panel-stake body with 14-gauge welded steel understructure and thoroughly seasoned oak floor is available for the 130-inch wheelbase Model KB-3 chassis. The one-piece front section and the two-piece side sections are removable and are fitted to the top with interlocking connections. Inside measurements are 96 inches long, 78 inches wide and 30 inches high.

AMERICA'S LIGHT-DUTY LEADER

AMERICA'S Light-Duty Leader — the International Model KB-3 — offers top value in stamina, economy and performance; impressive, modern styling; brilliant engineering; added safety; and driver comfort. In this smart, easily handled, smooth-riding truck you get all-truck construction and the utmost for your transportation dollar.

The sturdy, well-reinforced frame; powerful, performance-proved **Green Diamond** 214 engine; and heavy-duty clutch and transmission — all engineered and built by International Harvester for truck service — assure long life and trouble-free, economical performance. Comparison with all other trucks in the light-duty field will prove what

International has achieved in this outstanding model.

Truck operators in steadily increasing numbers are turning to the full line of International trucks for the satisfactory and economical solution to their hauling problems. If a hauling job calls for a truck, there is an International of the right size and type to do the work efficiently and economically. When you buy Internationals you get precision-built trucks backed by over 40 years of truck-manufacturing experience plus an unparalleled nation-wide network of Company-owned and dealer service facilities. Thousands of International truck owners find this standardized service is a vital and natural factor in low-cost operation and long truck life.

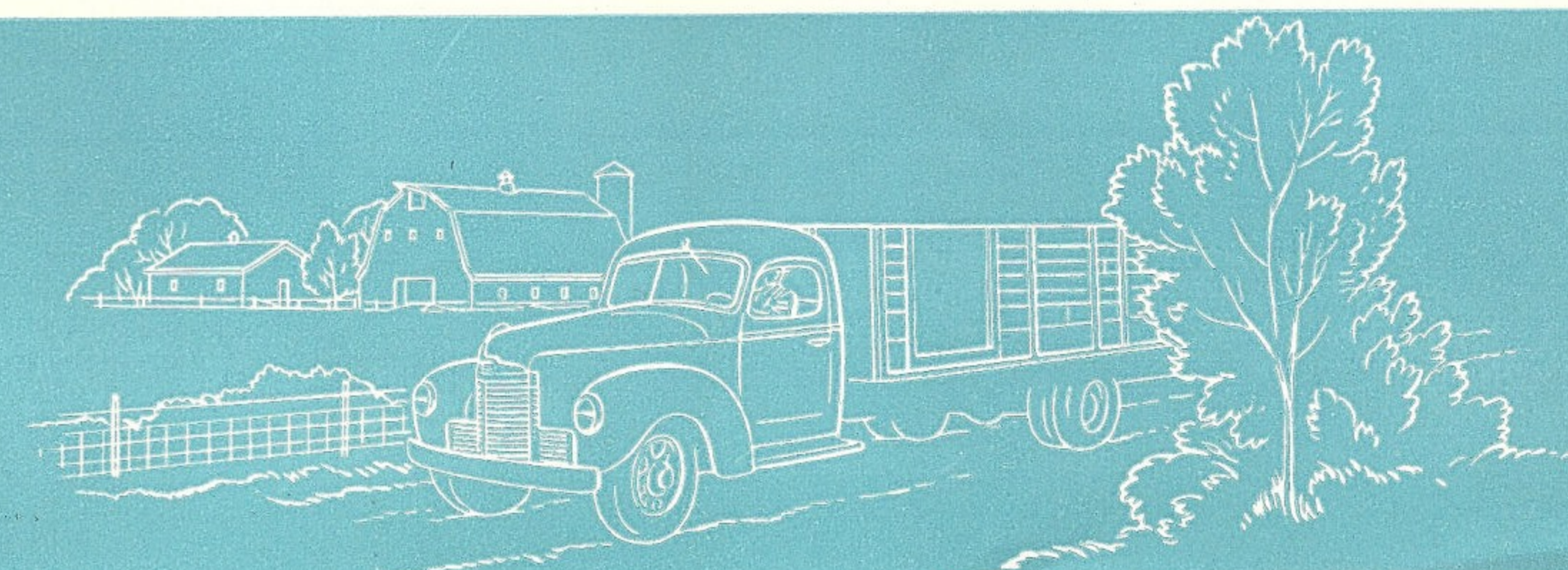

THE GREEN DIAMOND ENGINE

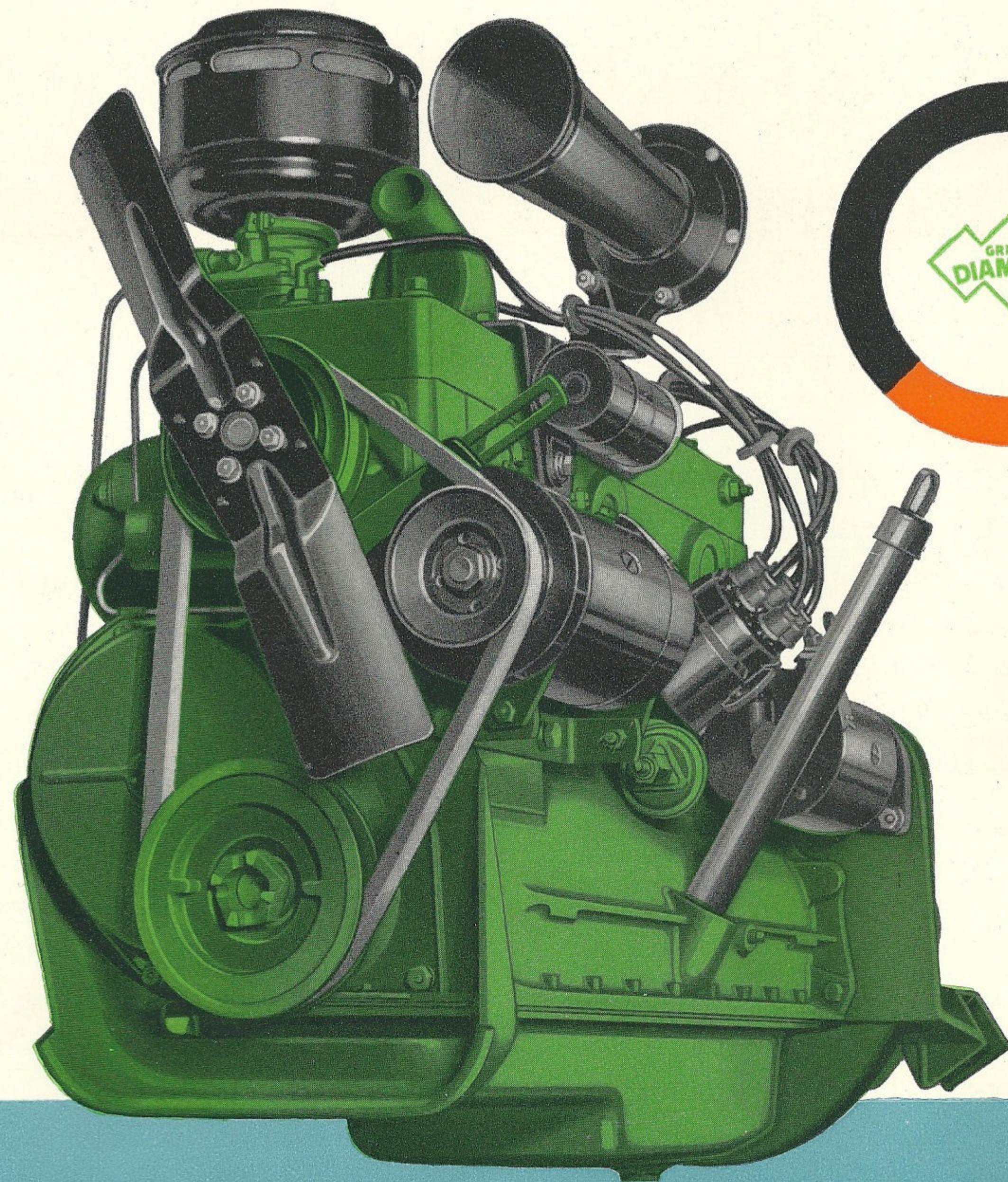

The new **Green Diamond** engine is designed and precision-built by International Harvester exclusively as a truck power plant. Basically simple in design, the **Green Diamond** engine is unusually rugged and incorporates many desirable features that contribute to smooth, quiet operation; effective performance; operating economy, and long life. In the sectional view below many important features are shown to advantage. Displacing 214 cubic inches, this six-cylinder engine develops 82.4 maximum brake h.p. at 3,400 r.p.m. and maximum torque of 160 lb.-ft. at

1,200 r.p.m. The heavy, counterbalanced crankshaft; long-skirted, aluminum pistons with four rings; full-floating piston pins; rifle-drilled connecting rods; and 10-inch, single-plate, vibration-dampened clutch are clearly shown. The engine is lubricated by a force-feed system. To eliminate any possibility of pumping dirt or impurities from the bottom of the oil pan into the lubrication system, a floating-type oil intake is provided. Oil is pumped under pressure to all main and connecting-rod bearings, piston pins, camshaft and the timing chain through drilled passages in the block.

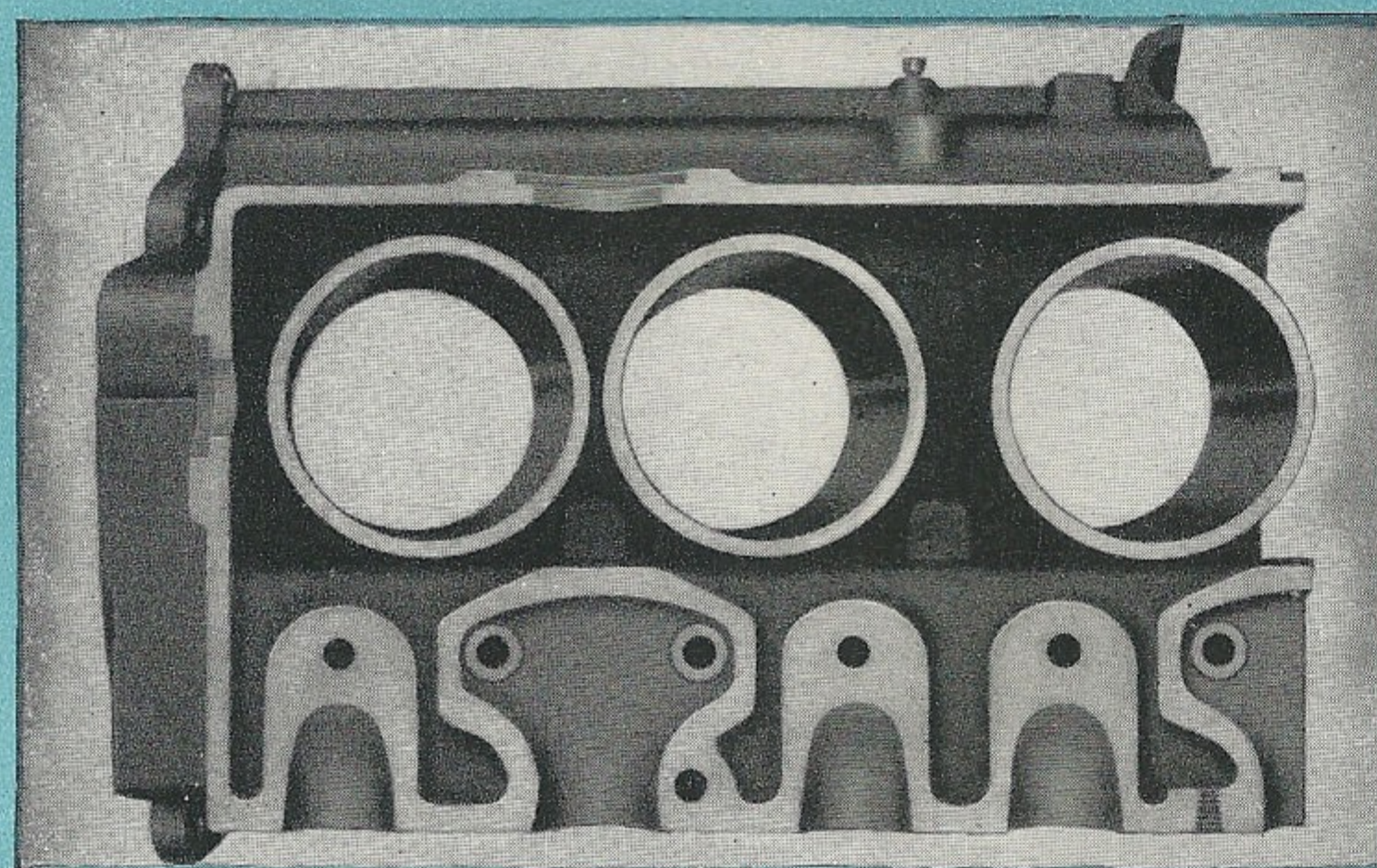

Constantly increasing road speeds combined with maximum loads place unusually severe demands upon cooling systems of truck engines. To adequately meet these conditions the **Green Diamond** engine is designed to provide water jackets which completely surround each cylinder bore and extend the full length of the cylinder.

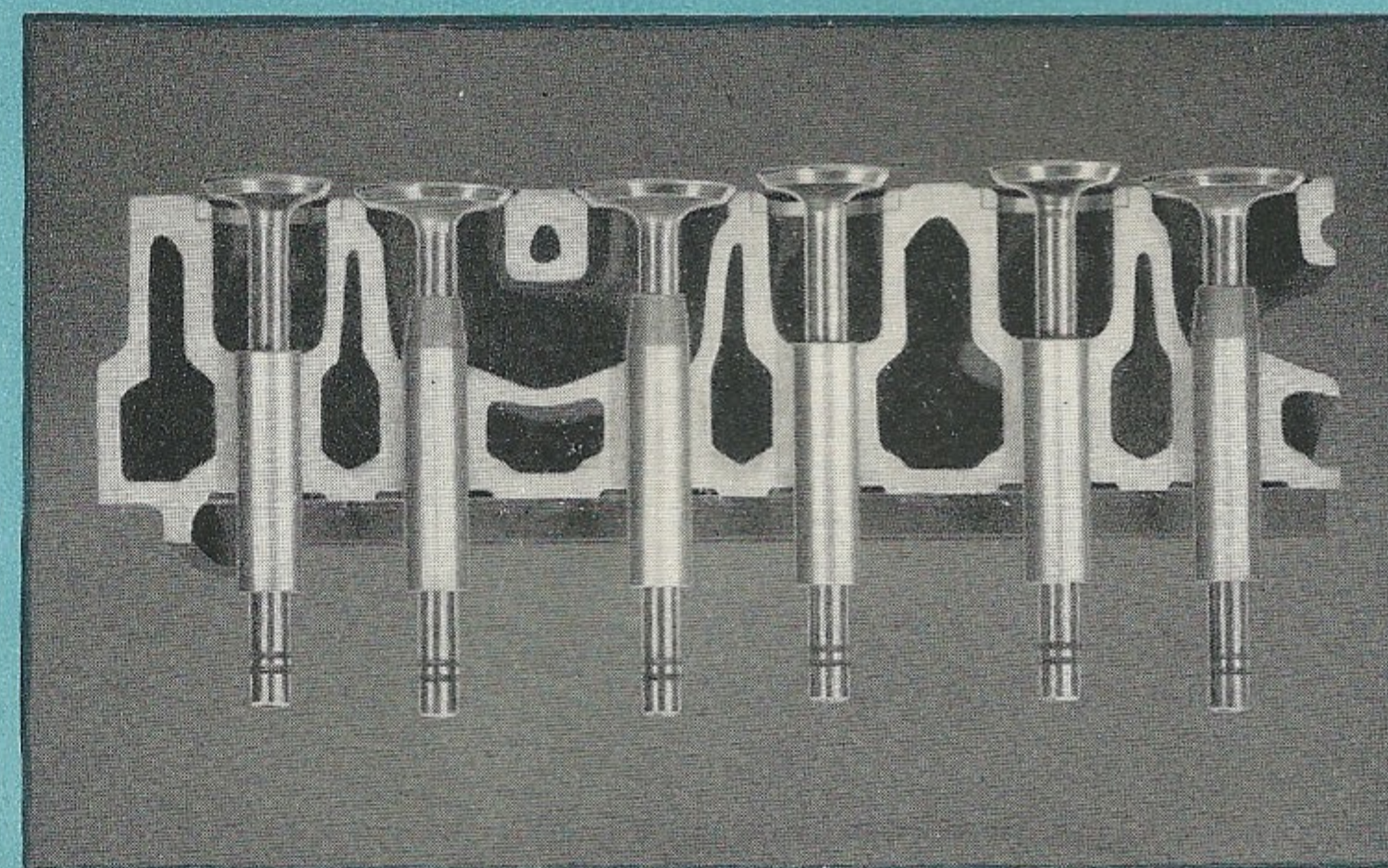

This cross section through part of the **Green Diamond** engine block shows the large water passages which completely surround intake and exhaust-valve ports; the large exhaust-valve ports which facilitate the escape of hot exhaust gases; the heavy-duty, truck-type intake and exhaust valves; and the hardened exhaust-valve seat inserts.

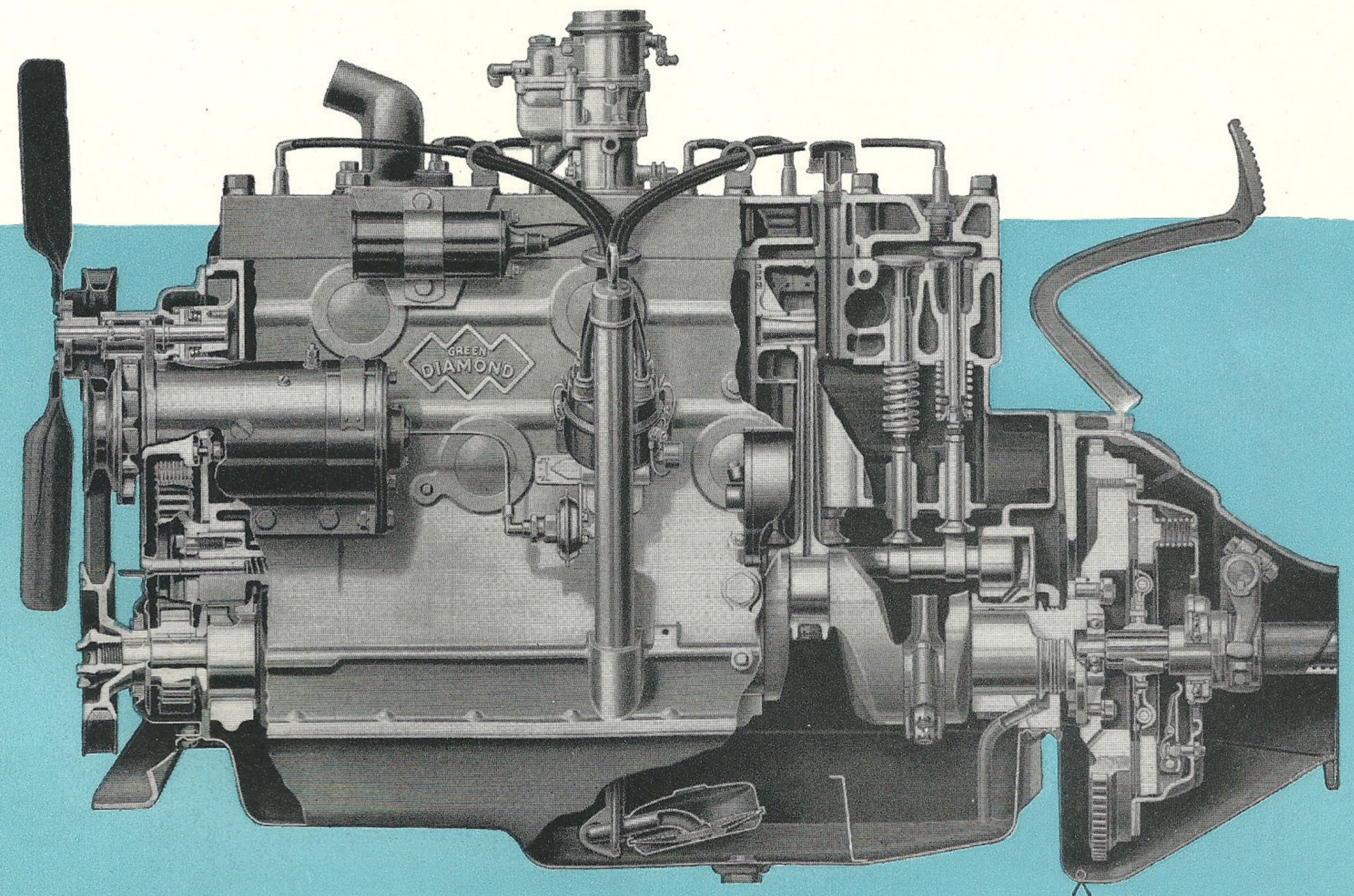

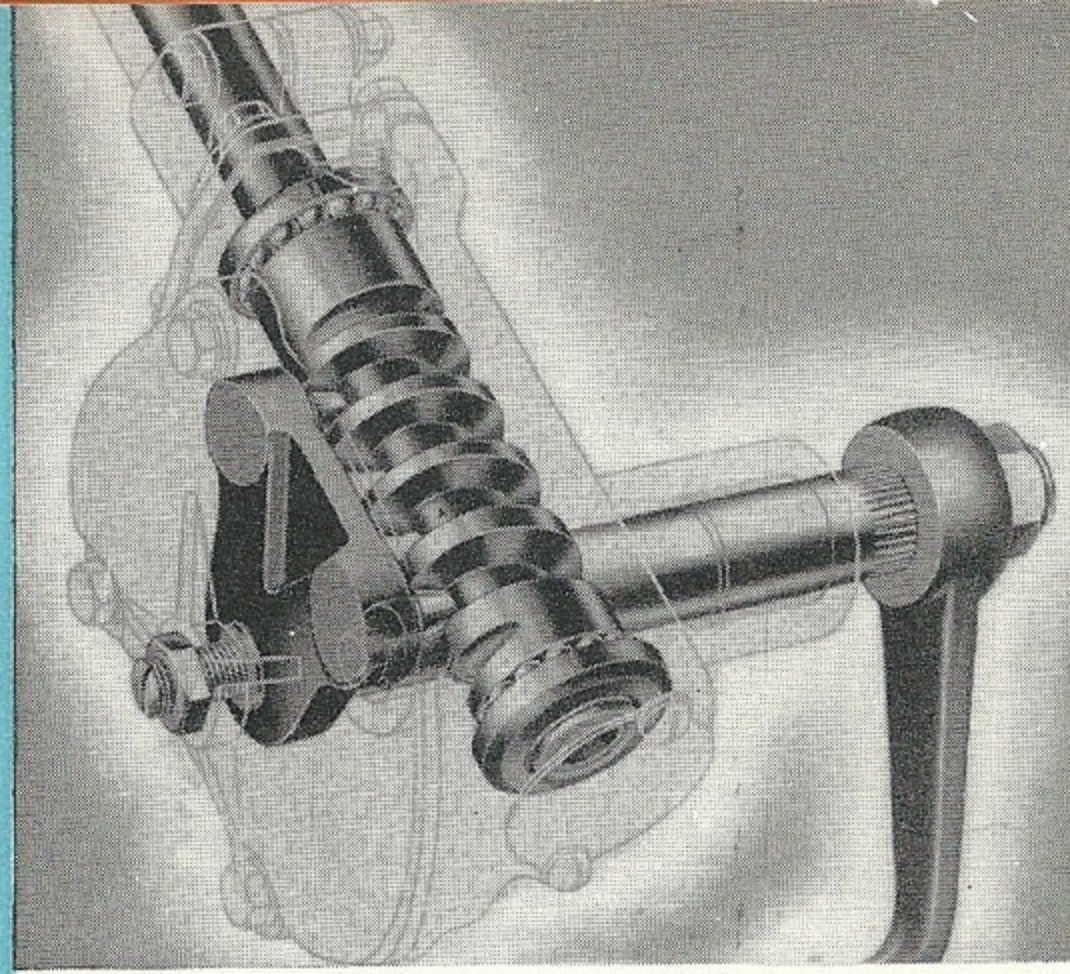

Safety at all speeds and easy steering under all road and load conditions are assured by the use of the cam-and-twin lever steering gear. The entire steering mechanism is fully enclosed in oil and dustproof housing.

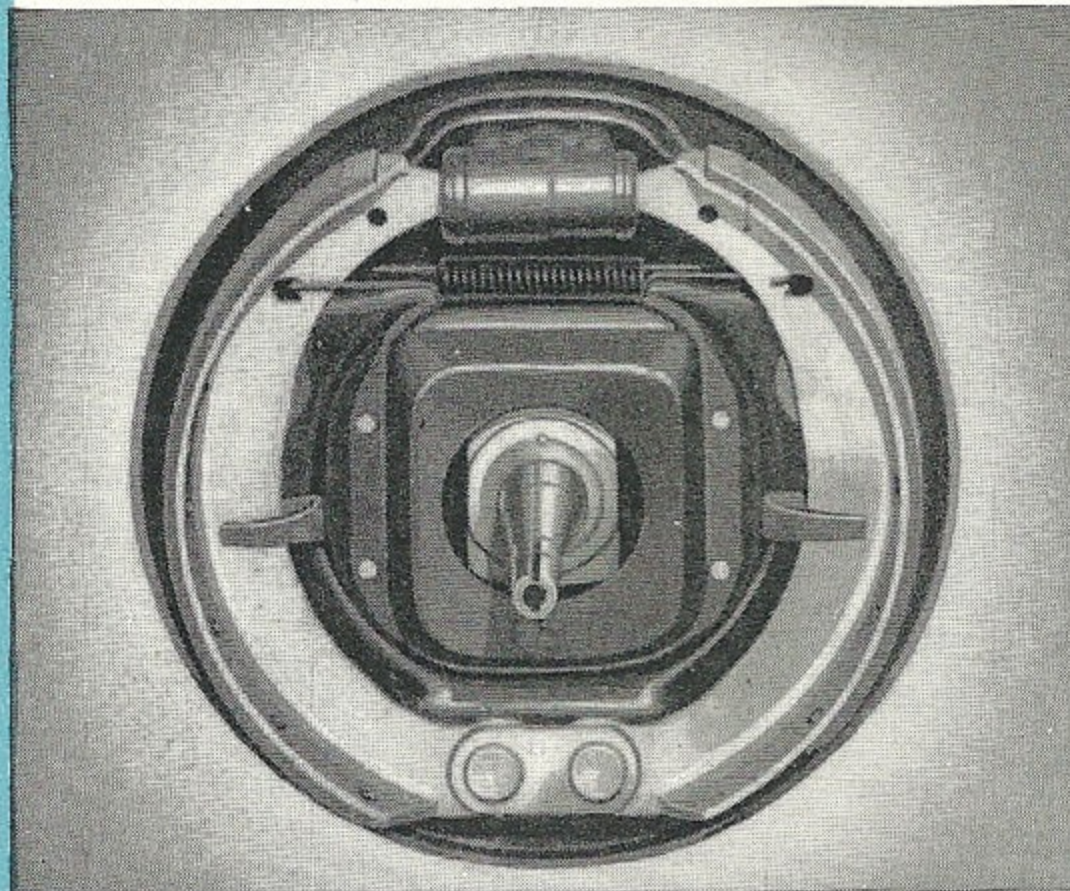

(Above) Two-shoe, double-anchored internal-expanding hydraulic brakes provide smooth, straight-line stops and braking effectiveness on all wheels with light pedal pressure. The two braking shoes are supported on the backing plate by two fixed anchor pins at the bottom of the brake.

STURDY

REAR AXLES AND BRAKES

(Below) This sectional view of part of a brake and brake drum shows: (a) the reinforcing rib which reduces the possibility of drum distortion and provides for heat dissipation; (b) the self-cleaning dirt slinger which prevents dirt and dust from entering the brake; (c) heavy section at the back of the drum; (d) drum mounting flange located close to center line of the brake.

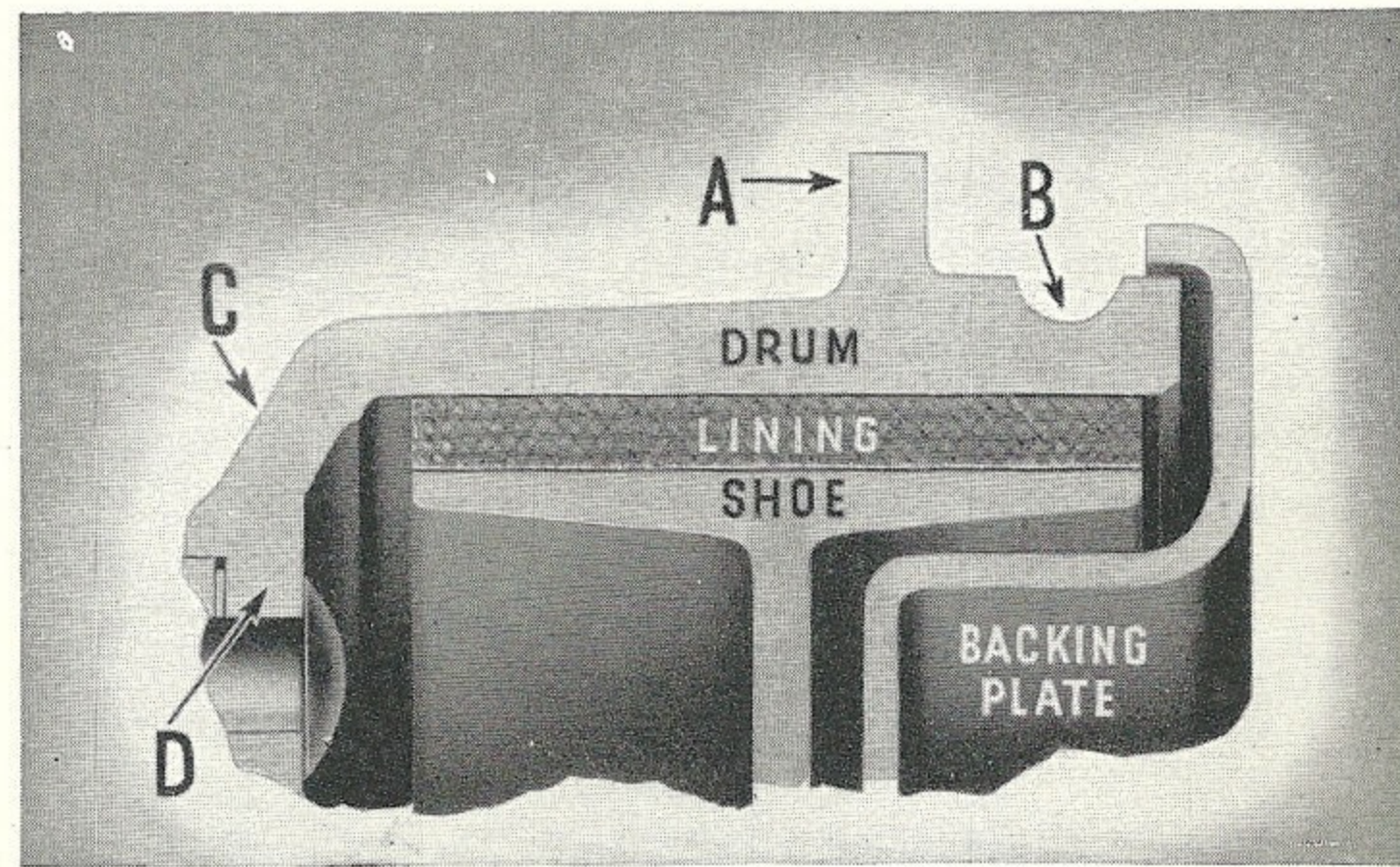

(Below) A cutaway view of the Model KB-3 sturdy, full-floating, spiral-bevel gear-drive rear axle. Axle shafts are chrome-molybdenum heat-treated steel with integral drive flanges, differential and axle shaft bearings are tapered rollers.

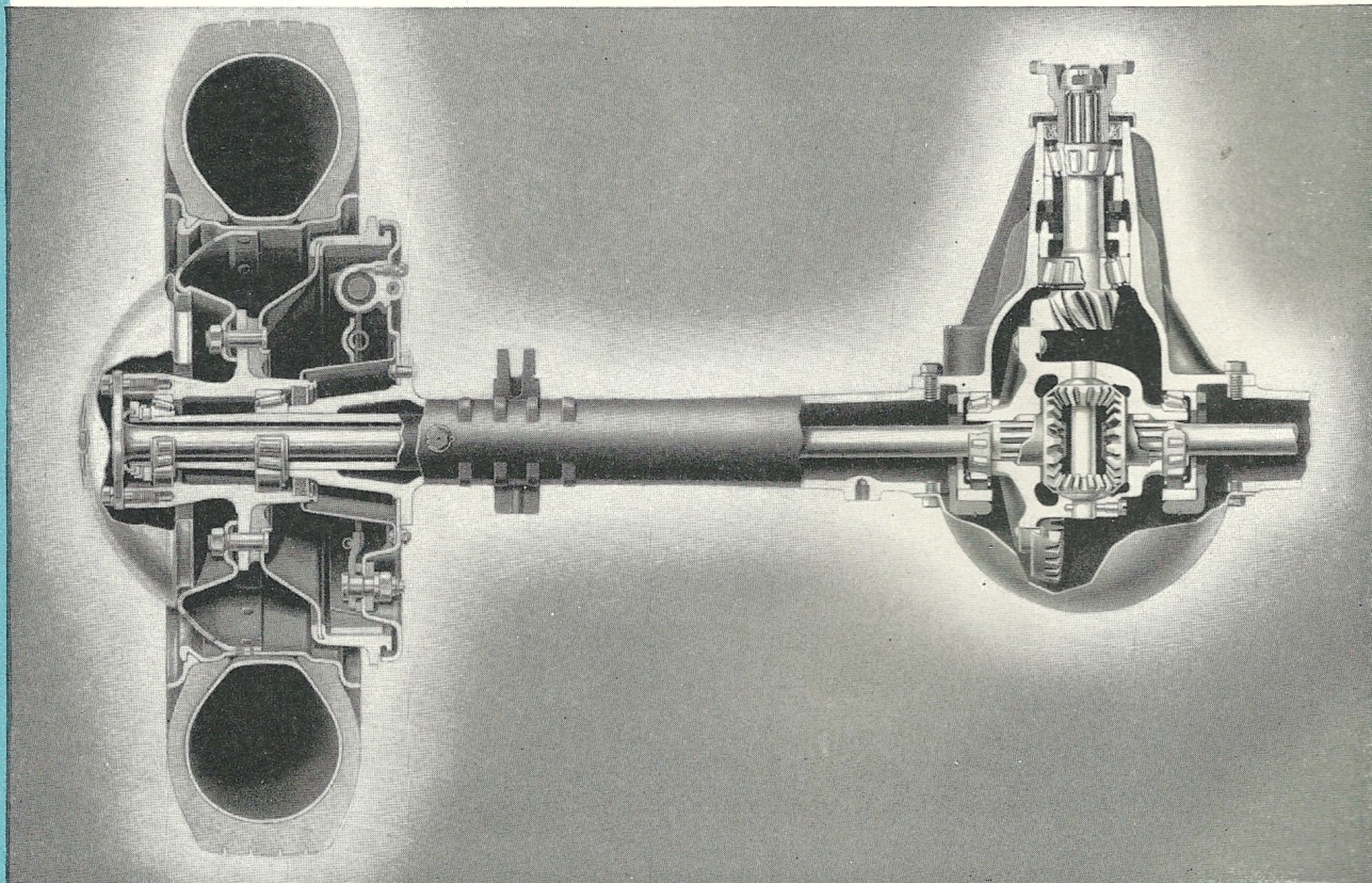

SPECIFICATIONS INTERNATIONAL MODEL KB-3

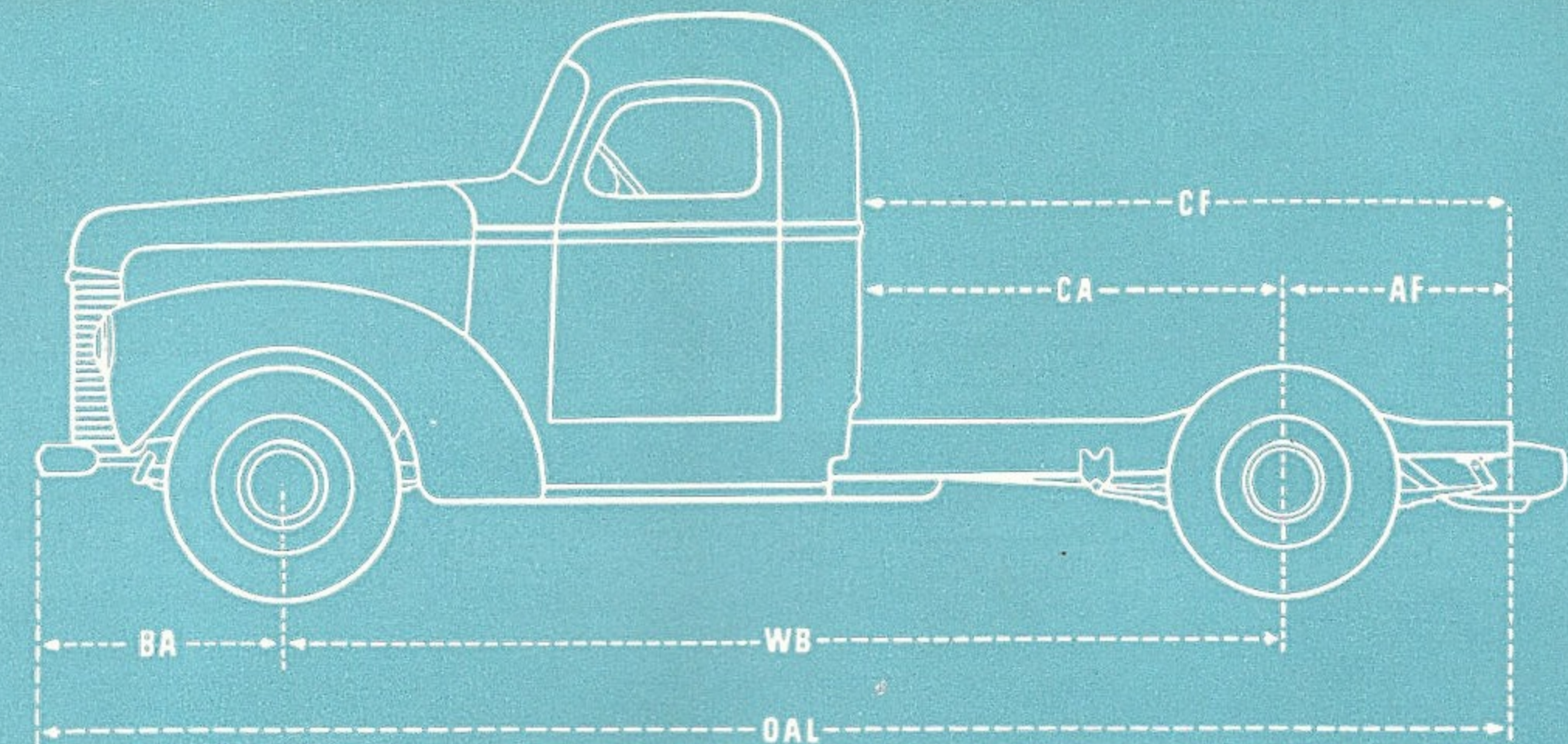

Gross Vehicle Weight Rating.....6,650 lb.

Carrying Capacity:
(cab, body, equipment, and payload).....3,600 lb.

Chassis Dimensions: (in inches) **Weights:** (in pounds)

Wheelbase length (WB).....	113	130
Overall length, with front bumper (OAL)....	175 $\frac{9}{16}$	192 $\frac{9}{16}$
Back of cab to c/l of rear axle (CA).....	38	55
C/l of rear axle to end of frame (AF).....	30	30
Back of cab to end of frame (CF).....	68	85
Bumper to center of front axle (BA).....	32 $\frac{9}{16}$	32 $\frac{9}{16}$
Turning radius with bumper clearance (feet)	22	24 $\frac{1}{2}$
Chassis weight, including fuel, oil, water and 7.50-16, 6-ply tires (approximately)....	3,050	3,080

The following dimensions are with 7.50-16, 6-ply tires.
Tread—front wheels, 58 $\frac{1}{2}$ in.; rear wheels, 63 in.
Clearance under front axle, 9 in.; under rear axle, 8 $\frac{1}{16}$ in.
Overall width—front, 73 $\frac{1}{8}$ in.; rear, 76 $\frac{1}{2}$ in.

Frame: Pressed steel channel; depth, 6 $\frac{1}{2}$ in.; thickness, $\frac{1}{4}$ in.; width of flange, 2 $\frac{9}{16}$ in.; width, front, 27 $\frac{9}{16}$ in.; rear, 44 $\frac{1}{16}$ in.

Engine, International Green Diamond 214: Six-cylinder, cast-in-block, L-head type; 3 $\frac{5}{16}$ -in. bore, 4 $\frac{1}{8}$ -in. stroke. Displacement, 214 cu. in.; compression ratio, 6.3. A.M.A. rating, 26.3 h.p.; maximum brake h.p., 82.4 at 3,400 r.p.m. Maximum torque, 160 lb.-ft. at 1,200 r.p.m. Four steel-backed, replaceable-shell, precision-type main bearings; total projected area, 16.24 sq. in. Six replaceable-shell, precision-type connecting-rod bearings. Exhaust-valve seat inserts.

Lubrication: Full-pressure feed to all main, connecting-rod and piston-pin bearings, camshaft, and timing chain. Gear-type, gear-driven oil pump. Floating oil strainer. Oil capacity, 5 $\frac{1}{2}$ qt.

Cooling System: Centrifugal pump circulation, fin-and-tube radiator; fan and pump driven by V-type belt. Capacity, 13 $\frac{1}{2}$ qt.

Ignition: Vacuum control, full-automatic distributor.

Generator: 30-ampere, 200-watt, shunt-wound, belt-driven.

Lights: Sealed-beam headlights.

Battery: 6-volt, 15-plate.

Starting Motor: 6-volt.

Carburetor: Downdraft type. Oil-bath-type air cleaner.

Fuel System: Fuel pump. 15-gal. tank inside frame. Gasoline filter.

Clutch: 10-in., single-plate.

Transmission: 3 speeds forward, 1 reverse; sliding gear, selective type, mounted in unit with engine. Gearshift on steering post.

Transmission Reductions: First, 3.053 to 1; second, 1.481 to 1; third, 1 to 1; reverse, 3.707 to 1.

Propeller Shaft: Large-diameter steel tubing.

Universal Joints: All-metal, roller-bearing, anti-friction type.

Front Axle: Drop-center, I-beam, heat-treated steel drop-forging. Fore and aft steering hook-up, tie rod at rear for protection.

Rear Axle: Full-floating, spiral-bevel gear type. Chrome-molybdenum steel axle shafts. One-piece, malleable-iron, banjo-type housing. Differential and axle-shaft bearings are tapered rollers.

Axle Reductions: 4.22 to 1, 4.875 to 1, 5.28 to 1, and 6.50 to 1.

Steering Gear: Cam-and-twin-lever type.

Brakes: Service: 4-wheel, hydraulic, internal-expanding, two-shoe, double-anchor type. Hand: Propeller shaft. All brakes fully enclosed.

Springs: Semi-elliptic. Front, 1 $\frac{3}{4}$ x 40 $\frac{1}{2}$ in.; rear, 2 $\frac{1}{4}$ x 51 in.

Wheels: Pressed steel, 16-in. disc type.

Tires: 7.00 x 16—6-ply, front and single rear.

Controls: Gearshift on steering post. Throttle, light, and choke controls on instrument panel. Accelerator, clutch, and service brakes operated by pedals. Hand brake lever located at left side of driving compartment.

Standard Equipment: Flat-back cowl and dash; spare wheel; shock absorbers; oil-type air cleaner, jack and tools.

Special Equipment: All-steel cab, dual windshield wipers, 4-speed transmission, oil filter, optional tires, pick-up body, 8 $\frac{1}{2}$ -foot panel body, 8-foot stake body and auxiliary rear springs will be supplied at extra cost when specified on order.

Finish: Frame, wheels, and running boards, black. Grille, hood, cab, and fenders, optional colors—No. 10 dark green, No. 22 maroon, No. 50 red, or No. 60 black.

Specifications subject to change without notice.

170 COMPANY-OWNED BRANCHES AND SERVICE STATIONS . . . DEALERS EVERYWHERE

Aberdeen, S. Dak.
Abilene, Tex.
Akron, Ohio
Albany, N. Y.
Allentown, Pa.
Altoona, Pa.
Amarillo, Tex.
Atlanta, Ga.
Auburn, N. Y.
Aurora, Ill.
Baltimore, Md.
Bangor, Maine
Baton Rouge, La.
Beaumont, Tex.
Billings, Mont.
Binghamton, N. Y.
Birmingham, Ala.
Bismarck, N. Dak.
Boston, Mass.
Bridgeport, Conn.
Bronx, N. Y.
Brooklyn, N. Y.
Buffalo, N. Y.
Burlington, Vt.
Camden, N. J.
Cedar Rapids, Iowa
Charleston, S. C.
Charlotte, N. C.
Cheyenne, Wyo.
Chicago, Ill. (3)
Cincinnati, Ohio
Clarksdale, Miss.
Cleveland, Ohio (2)
Columbus, Ohio
Council Bluffs, Iowa
Dallas, Tex.
Davenport, Iowa
Dayton, Ohio
Decatur, Ill.
Denver, Colo.
Des Moines, Iowa
Detroit, Mich. (2)
Dubuque, Iowa
Duluth, Minn.
East Hartford, Conn.
Eau Claire, Wis.
Elizabeth, N. J.

Elmira, N. Y.
El Paso, Tex.
Ephrata, Pa.
Erie, Pa.
Evansville, Ind.
Fargo, N. Dak.
Fort Dodge, Iowa
Fort Wayne, Ind.
Fort Worth, Tex.
Fresno, Calif.
Gary, Ind.
Glendale, Calif.
Grand Forks, N. Dak.
Grand Island, Nebr.
Grand Rapids, Mich.
Great Falls, Mont.
Green Bay, Wis.
Greensboro, N. C.
Harrisburg, Pa.
Houston, Tex.
Hutchinson, Kans.
Indianapolis, Ind.
Jackson, Mich.
Jacksonville, Fla.
Jersey City, N. J.
Kankakee, Ill.
Kansas City, Mo.
Kansas City, Kans.
Knoxville, Tenn.
La Fayette, Ind.
Lexington, Ky.
Lincoln, Nebr.
Little Rock, Ark.
Long Island City, N. Y.
Los Angeles, Calif. (2)
Louisville, Ky.
Madison, Wis.
Mankato, Minn.
Mason City, Iowa
Memphis, Tenn.
Milwaukee, Wis.
Minneapolis, Minn.
Minot, N. Dak.
Nashville, Tenn.
Newark, N. J.
New Orleans, La.
New York, N. Y.

Norfolk, Va.
Oakland, Calif. (2)
Oklahoma City, Okla.
Omaha, Nebr.
Parkersburg, W. Va.
Paterson, N. J.
Peoria, Ill.
Philadelphia, Pa. (2)
Pittsburgh, Pa.
Portland, Maine
Portland, Oreg.
Pottsville, Pa.
Poughkeepsie, N. Y.
Presque Isle, Maine
Providence, R. I.
Quincy, Ill.
Reading, Pa.
Richmond, Va.
Rochester, N. Y.
Sacramento, Calif.
Saginaw, Mich.
St. Cloud, Minn.
St. Joseph, Mo.
St. Louis, Mo. (2)
St. Paul, Minn.
Salina, Kans.
Salt Lake City, Utah
San Antonio, Tex.
San Diego, Calif.
San Francisco, Calif.
Savannah, Ga.
Schenectady, N. Y.
Scranton, Pa.

Seattle, Wash. (2)
Shreveport, La.
Sioux City, Iowa
Sioux Falls, S. Dak.
Somerville, Mass.
South Bend, Ind.
Spokane, Wash.
Springfield, Ill.
Springfield (West), Mass.
Springfield, Mo.
Springfield, Ohio
Sweetwater, Tex.
Syracuse, N. Y.
Tacoma, Wash.
Terre Haute, Ind.
Toledo, Ohio
Topeka, Kans.
Trenton, N. J.
Tulsa, Okla.
Utica, N. Y.
Washington, D. C.
Waterbury, Conn.
Waterloo, Iowa
Watertown, N. Y.
Watertown, S. Dak.
West Haven, Conn.
Wichita, Kans.
Wichita Falls, Tex.
Wilkes-Barre, Pa.
Williamsport, Pa.
Wilmington, Del.
Worcester, Mass.
York, Pa.
Youngstown, Ohio

● Branches in Canada ●

Brandon, Man.
Calgary, Alta.
Edmonton, Alta.
Hamilton, Ont.
Lethbridge, Alta.
London, Ont.
Montreal, Que.
North Battleford, Sask.
North Bay, Ont.

Ottawa, Ont.
Quebec, Que.
Regina, Sask.
St. John, N. B.
Saskatoon, Sask.
Toronto, Ont.
Vancouver, B. C.
Winnipeg, Man.
Yorkton, Sask.

MOTOR TRUCK DIVISION INTERNATIONAL HARVESTER COMPANY

180 NORTH MICHIGAN AVE.

CHICAGO 1, ILLINOIS, U.S.A.

INTERNATIONAL PARTS, SERVICE AND ACCESSORIES

Always available from a near-by dealer or branch are International-engineered replacement parts, expert maintenance and repair service, and Company-approved accessories.

Engineered replacement parts are of the same high quality and precision as the parts used in new trucks and are sold for use only on specified truck models, assuring accurate fit.

Expert service is provided by specially trained and supervised mechanics, who use special tools and instruments and who know exact International specifications.

Approved accessories of leading manufacturers are sure to give satisfaction when Company-approved for use with International trucks and sold under IH part numbers.

International exchange units are fully reconditioned to new-part standards, and lessen the costs and delays of required unit replacements.