

INTERNATIONAL®



1200A

RATINGS

MAXIMUM GROSS VEHICLE WEIGHTS:

Standard.....	5,500 lbs.
With Heavy-Duty Rear Springs.....	7,300 lbs.

STANDARD EQUIPMENT

AXLE, FRONT

FA-10 2,700-lb capacity
Heat-treated forged-steel I beam

AXLE, REAR

RA-16 5,500-lb capacity
Hypoid single reduction, 9 $\frac{3}{4}$ " ring gear
Full floating, induction hardened axle shaft
Ratios: 4.10, 4.56 or 4.88 to 1

BRAKES, PARKING

Mechanical control of rear service brakes
Foot pedal applied, finger lever released
Total lining area: 90.6 sq. inches

BRAKES, SERVICE

Self-adjusting hydraulic
Single cylinder, single-piston front
Single-cylinder, double-piston rear
Size: 12 x 1 $\frac{3}{4}$ " front, 12 x 2" rear
Total lining area: 174.0 sq. inches

CAB

All steel, with safety glass windows and sweep-around windshield
Door locks both sides with safety latches
Non-glare instrument panel with ammeter, fuel, water temperature and oil pressure gauges
Full width adjustable seat, with Torflex spring construction, vinyl upholstery and polyurethane foam cushion

CAB (Continued)

Acoustical roof headliner
Rubber floor mat with sound deadening insulation
Sun visor for driver; inside rear view mirror
Ash tray; hand choke
Two-speed electric windshield wipers
Seat belt anchors

CLUTCH

10-inch 9-spring single plate
Hydraulic control; vibration dampener

COOLING SYSTEM

18.5 quart system capacity
Radiator frontal area: 497 sq. inches

ELECTRICAL SYSTEM

12-volt 37-amp alternator
50 amp-hr, 54-plate battery
Fuse panel in glove compartment
Dual stop and tail lights
Dome light; single electric horn
Directional signals: front in parking lights, rear in stop lights

ENGINE

International BG-241 gasoline six
Gross BHP: 140.8 @ 3800 rpm
Gross torque: 223.5 lb-ft @ 2000 rpm
241 cu. in. displmt.; 7.5 to 1 compr. ratio
Oil bath air cleaner; full-flow oil filter

FINISH

Chassis: black; bumper: white
Hood, cab, fenders and wheels:
choice of any standard IH color

FRAME

Pressed steel channel main rails
7 x 3 x 0.179"; 4.81 section modulus
Formed-channel front bumper

FUEL TANK

19-gallon, mounted under cab

STEERING

S-3 gear, with 17-inch steering wheel

SUSPENSION

Semi-elliptic leaf springs
Front: 2 $\frac{1}{2}$ x 46"; 2,820-lb capacity
Rear: 2 $\frac{1}{2}$ x 52"; 3,580-lb capacity
Front and rear shock absorbers

TRANSMISSION

T-4 three-speed synchromesh, direct
Gear shift lever on steering column
Ratios: 3.03, 1.64, 1.00; 3.68 rev.

WHEELS AND TIRES

Single front and rear with spare rim
7-17.5 6-PR truck type tires
6-stud disc wheels, with 5.25 DC rims

OPTIONAL EQUIPMENT

AXLE, REAR

RA-17, 5,500-lb capacity single reduction, with Powr-Lok limited slip differential
Ratios: 4.1, 4.56, 4.88

BODIES

7-ft or 8 $\frac{1}{2}$ -ft regular pickup, with underslung or optional inner body tire carrier

7-ft, 8-ft or 8 $\frac{1}{2}$ -ft Bonus-Load pickup body, with inner body tire carrier

Travelall body, with four side doors, rear tailgate with electrically operated roll-down window, white rear bumper, inner body tire carrier; front seat belts and padded dash.

BODIES (Continued)

Optional: Full width fold down center seat, removable rear seat, panel-type rear doors, trim packages

Panel body with four side doors, double rear doors, driver's individual bucket seat, dual stop and tail light, white rear bumper

6-ft Bonus-Load pickup body with inner body tire carrier, for Travelette cab
8-ft stake or platform body

BRAKES, SERVICE

Vacuum power assist system

CAB

Deluxe interior trim package
Custom trim package
Exterior trim package
Safety package
4-door 6-passenger Travelette cab
Flat back cowl or front end section, in lieu of cab
Full width or passenger seat, for panel body
Super-capacity heater-defroster
Fresh air or recirculating heater-defroster
Single* or dual cowl mirrors, chrome
Right or left fixed outside mirror
Right side sun visor; tinted glass
Right or left side arm rest
Glove compartment lock
Electric windshield washer*
*Standard with Travelall

Illustration May Include Optional Equipment

OPTIONAL EQUIPMENT (Continued)

CLUTCH

11-inch 9-spring
11-inch 12-spring
12-inch 12-spring

COOLING SYSTEM

Increased capacity system
Permanent anti-freeze: -10°F or -40°F

ELECTRICAL SYSTEM

52-amp alternator
60 or 70 amp-hr battery
Dual electric horns; radio
Traffic hazard switch*; cigar lighter
Three front marker lights
Two front corner lamps
Camper electrical connector
Backup lights*
*Standard on Travelall

ENGINE

BG-265 153.5 BHP gasoline six
V-266 154.8 BHP gasoline V8
V-304 193.1 BHP gasoline V8

ENGINE (Continued)

V-304 LPG 180-BHP LPG V8
Exhaust emission control
Heavy-duty oil bath air cleaner
High altitude equipment
Magnetic fan drive
Hand throttle control; carburetor heater
Velocity-type engine governors
Automatic choke

FRAME

Underslung tire carrier, for
Bonus-Load pickup body,
chassis and cab, Travelall or Panel
Left side mounted outside tire carrier with
regular pickup body
Spare tire lock
Chrome front and rear bumper
White rear bumper

FUEL TANK

Auxiliary 14-gallon tank under
left side of Travelall body with
dash-mounted tank selector

STEERING

Hydraulic power assist system

SUSPENSION

3,260-lb capacity HD front springs
5,890-lb capacity HD rear springs
6,590-lb capacity HD main and
auxiliary rear springs

TRANSMISSION

T-7 HD three-speed, with
floor-mounted control lever
T-15 HD four-speed, with
floor-mounted control lever
T-28 three-speed automatic
T-34 HD 5-speed, overdrive
T-36 HD 5-speed, direct
Oil cooler for T-28

WHEELS AND TIRES

Optional tires sizes as shown below
Chrome hub caps, front and rear

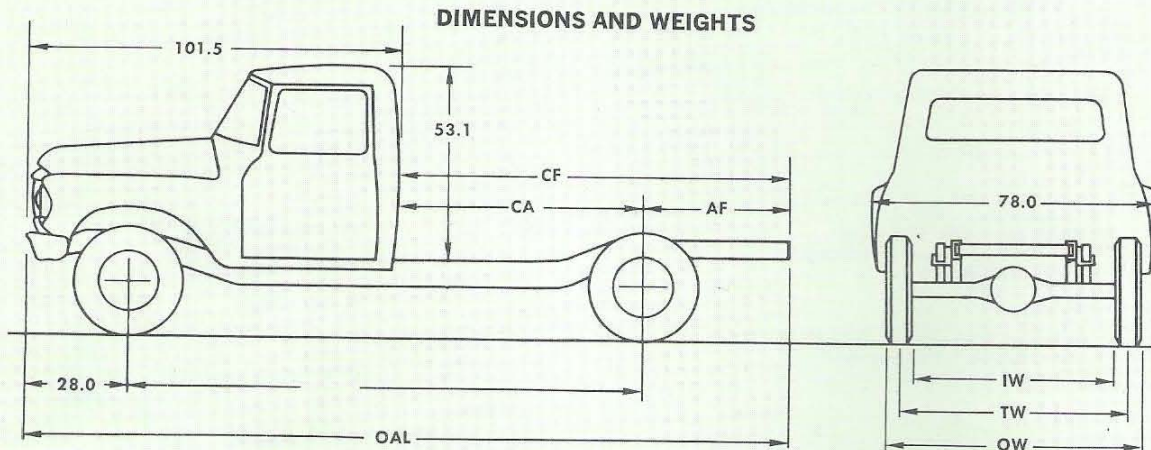

DIMENSIONS with 7 x 17.5 TIRES			
Overall Width: 78" at front fenders	Ground Clearance: 7.2" at front axle	Frame Height at Rear Axle: 27.4" empty	
Overall Height: 70.7" at top of cab	8.3" at rear axle	24.8" loaded	

CHASSIS DIMENSIONS and WEIGHTS									
WB	CHASSIS WEIGHTS, LBS.*			DIMENSIONS				TURNING RADIUS	
	Front	Rear	Total	CA	CF	AF	OAL	To Centerline of Tire	With Bumper Clearance
115"	2,290	1,120	3,410	42"	85.5"	43.5"	187"	19 ft. 6 in.	21 ft. 0 in.
119"	2,290	1,125	3,415	45.5"	85.5"	40"	187"	20 ft. 3 in.	21 ft. 6 in.
122"	2,290	1,125	3,415	49"	85.5"	36.5"	187"	20 ft. 6 in.	22 ft. 0 in.
131"	2,305	1,125	3,430	57.5"	103.5"	46"	205"	22 ft. 0 in.	23 ft. 3 in.
140"***	2,480	1,370	3,850	31.5"	71.5"	40"	208.5"	23 ft. 3 in.	24 ft. 9 in.

*Chassis and cab with standard equipment, oil, fuel and water **With Travellette Cab.

TIRE DIMENSIONS									
Tire Size	TUBELESS ON DISC WHEELS			TIRES AND TUBES ON DISC WHEELS					
	7x17.5	8x17.5	8x19.5	6.50x16	7.00x16	7.50x16	7.00x18	6.50x20	7.00x20
Rim Size	5.25	5.25	5.25	4.50E	5.50F	5.50F	5.50S	5.00R	5.00R
Outside width OW	70.3"	70.7"	70.7"	70.0"	70.6"	71.2"	70.5"	68.9"	70.5"
Tread width TW	63.0"	63.0"	63.0"	63.0"	63.0"	63.0"	63.0"	63.1"	63.1"
Inside width IW	55.7"	55.3"	55.3"	56.0"	55.4"	54.8"	55.5"	56.3"	55.8"
Chain clearance	6.86"	6.66"	6.66"	7.03"	6.72"	6.42"	6.77"	7.30"	7.04"
Front Tread	62.8"	62.8"	62.8"	62.8"	62.8"	62.8"	62.8"	61.4"	61.4"

In order that product improvements may be introduced at any time, specifications are subject to change without notice.

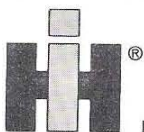

INTERNATIONAL HARVESTER COMPANY • 401 NORTH MICHIGAN AVE. • CHICAGO, ILLINOIS 60611

CT-400-D. AD-4237-S2. 2-1-S.

ORDER AD SPEC. SHEETS ON AD-4130.

Litho in United States of America