

FORD FALCON UTES & VANS.

"When a man works hard, he deserves
all the comfort he can get."



Ford Australia - We're moving with you.



Comfort & Style

They have to be two of the big reasons why many people prefer Falcon Utes and Vans. Comfortable passenger compartments. Good looking body styles.

Falcon Utes and Vans offer you many of the features you'll find in the latest Falcon GL sedan. Because when a man works hard, he deserves all the comfort he can get.

The Falcon commercial range offers you choice. There are two base models and two GL models in the Ute and Van line-up. Doors are full frame for side window rigidity and sure closing against dust and draughts. Side air extraction windows assist flow-through ventilation. Rectangular z-beam quartz halogen headlights provide excellent night driving visibility and combine with the re-designed grille to present a stylish front.

Illustrated: Ford Falcon GL Van. The side glass in load compartment and the lift-up/drop-down tailgate are standard.

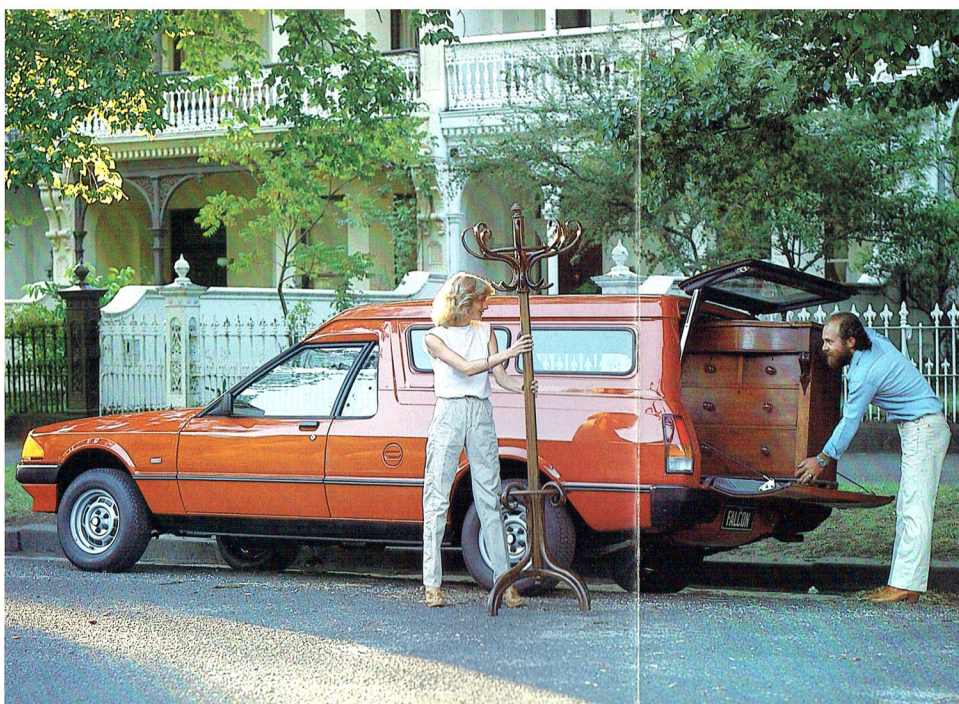

Illustrated: Ford Falcon GL Ute. Bungi cord-type tonneau cover fitted as standard.

Illustrated on front cover: Falcon Ute, Falcon Van, and Falcon GL Ute interior.

Power and performance

Power is job-matched with Falcon Utes and Vans being equipped with the fuel-efficient Ford Alloy Head II engine. In standard form, base models are powered by the 3.3 litre engine, GL models by the more powerful 4.1 litre engine. Falcon offers you power to spare, even when fully loaded. In standard form, all models are equipped with 3-speed manual column shift transmissions.

After hours, you've got the smooth driving performance and effortless cruising ability of the advanced six-cylinder power-plant fitted with electronic ignition. You can rely on Falcon Utes and Vans with the Alloy Head II engine to take you to all the places a car can go. Stopping power comes from power-assisted front disc brakes acting in combination with rear drum brakes.

Performance can also be looked upon as the ability to go on working year after hard-working year, which is another strong-point of Falcon Ute and Van design.

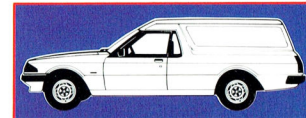
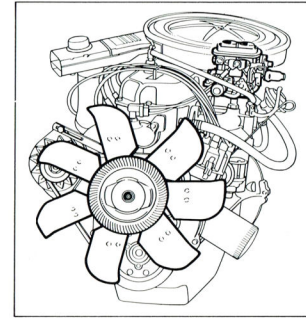

Ford Falcon Van

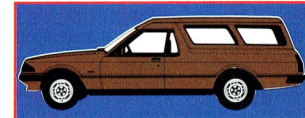

Ford Falcon GL Van

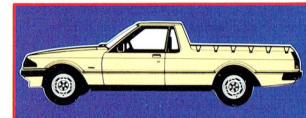

Ford Falcon GL Ute

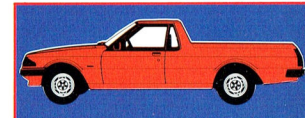

Ford Falcon Ute

Fuel efficiency and load carrying



The Alloy Head II engine is more fuel efficient than its predecessor due to its two-stage carburettor which provides improved fuel metering, and a temperature sensitive viscous clutch fan which is designed to absorb less engine power.

The heavy gauge ribbed steel load floors and double panelled sides, provide load carrying strength for Falcon Utes and Vans. Tyres are ER78S14 steel belt radials to strike a good balance between road holding ability and load-carrying durability.

The business end. Heavy gauge ribbed steel load floor for strength, plus easy loading and unloading. Double-panelled sides in load area.



Falcon offers you the choice: Side hinged rear doors are standard on the Falcon Van and are optional on the GL model. The lift-up/drop-down tailgate is standard on the GL Van and optional at extra cost on the base model Falcon Van.



With the Ford Centafold seat as standard, Falcon GL Utes and Vans go from two to three-seater at the flip of an armrest. Now two's company and three doesn't have to be a crowd.



For extra ventilation side-opening air extractor quarter vent windows are a standard feature on all Falcon Utes and Vans.

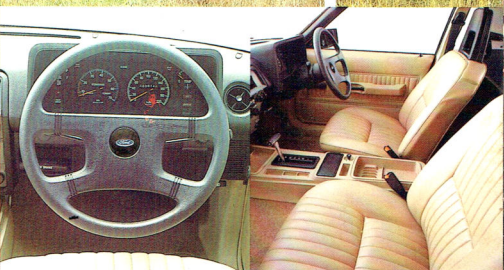

Falcon GL Ute/Van instrument panel.

Falcon GL Ute/Van interior with T-Bar automatic transmission and AM push-button radio both optional at extra cost.

About this brochure. This brochure is designed to provide you with a general introduction to the Ford Products (including available optional equipment) referred to, and should be read in conjunction with the latest specification sheets. Because of changes in conditions and circumstances Ford* reserves the right, subject to all applicable laws, at any time, at their discretion, and without notice to discontinue or change the features, designs, materials, colours and other specifications and the prices of their products, and to either permanently or temporarily withdraw any such products from the market without incurring any liability to any prospective purchaser or purchaser.

The latest specification sheet should be referred to for information on the availability, ordering and use of optional equipment. Always consult an Authorised Ford Dealer for the latest information with respect to features, specifications, prices, optional equipment and availability before deciding to place an order.

* FORD MOTOR COMPANY OF AUSTRALIA LIMITED
FORD SALES COMPANY OF AUSTRALIA LIMITED
1735 SYDNEY ROAD, CAMPBELLFIELD, VICTORIA, 3061.

Ford Falcon Utes and Vans Standard Equipment

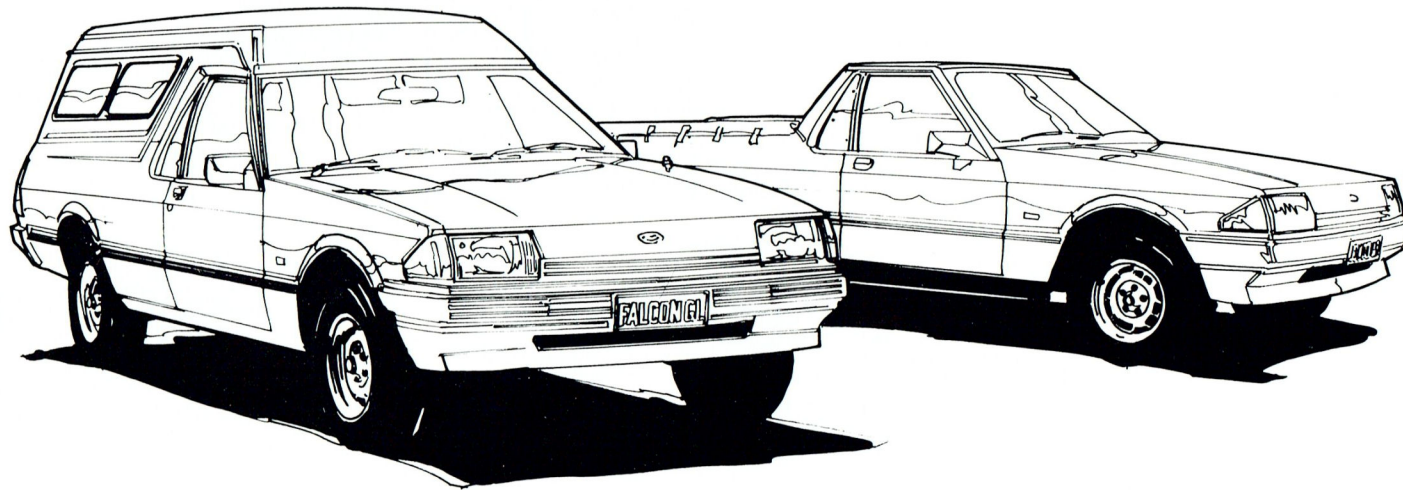

Ford Falcon Ute and Van Standard Equipment Highlights

- 3.3 litre Alloy Head II crossflow 6-cylinder engine.
- 3-speed manual column shift transmission.
- ER78S14 Steel belt radial ply tyres.
- Power assisted front disc brakes.
- Quartz halogen headlamps.
- Right and left hand exterior rear-view mirrors, each with interior remote control.
- Hazard flashers.
- 'Soft-feel' 4-spoke steering wheel.
- 'Lights-on' warning lamp.
- 3-speed heater/demister.
- Cigarette lighter.
- Prismatic day/night interior rear view mirror.
- Bench seat.
- Vinyl seat trim.
- Rubber passenger compartment floor mat.
- Interior courtesy light operated by side doors.
- Twin rear doors-side hinged. (Van).

Ford Falcon GL Ute and GL Van Standard Equipment Highlights - As for Falcon Ute and Van but with these different, upgraded or additional features.

- 4.1 litre Alloy Head II crossflow 6-cylinder engine
- Bodyside protection mouldings.
- Centafold front seat.
- Carpeted passenger compartment floor.
- Tonneau cover (bungie cord type) - Ute.
- Side windows - Van.
- Load area headlining - Van.
- Lift-up/drop-down tailgate - Van.



Ford Australia - We're moving with you.

FORD FALCON UTES AND VANS



Specifications

FORD FALCON UTES AND VANS

Engine:	3.3 litre	4.1 litre
Power DIN KW*	90 @ 4100	105 @ 3800
Torque DIN Nm*	240 @ 2500	310 @ 2300
Head/Block Material:	Head - aluminium alloy; Block - cast iron	
Cylinders	Six in line	
Main Bearings	7	
Fan	Temperature sensitive viscous clutch (TSVC)	
Bore	93.5mm	93.5mm
Stroke	79.5mm	93.3mm
Capacity	3273cc	4089cc
Valve Gear	Overhead valves with hydraulic tappets	
Camshaft Drive	Chain Drive	
Compression Ratio*	9.1:1	9.3:1
*Not necessarily applicable for vehicles manufactured for sale in NSW.		

Fuel System	3.3 litre	4.1 litre
	Weber model ADM dual venturi, sequential (progressive) throttle, fixed jet downdraft carburettor with electrically operated choke	
	Mechanical fuel pump	
	Fluid treated paper air cleaner element	

Suspension

Front	• Independent short/long arm • Progressive rate coil springs • Twin tube telescopic shock absorbers mounted co-axially within the coil springs. • 22mm diameter stabiliser bar	Rear	• Rigid Axle • Hotchass suspension • 6 leaf springs • Twin tube telescopic shock absorbers
-------	---	------	---

Dimensions

	Metric	Imperial
Overall length	4867mm	(191.6")
Overall width	1860mm	(73.2")
Overall height - Utility	1388mm	(54.6")
Overall height - Van	1604mm	(63.1")
Wheelbase	2947mm	(116.0")
Track - Front	1552mm	(61.1")
Track - Rear	1527mm	(60.1")
Ground Clearance	162mm	(6.4")
Max. load length (tailgate down)	2696mm	(106.1")
Max. load length (tailgate closed)	2134mm	(84.0")
Max. load height (unladen)	579mm	(22.8")
Usable fuel tank capacity	68 litres	(14.9 gal.)
Turning Circle	11.8m	(38.7 ft)
Cubic capacity (Utility)	1.1m ³	(38.8 ft ³)
Cubic capacity (Van)	2.8m ³	(98.9 ft ³)

Options - available at extra cost.

FORD FALCON UTES AND VANS

Convenience	Notes	Falcon		Falcon GL	
		Ute	Van	Ute	Van
Integrated air conditioning		OPT	OPT	OPT	OPT
AM Push Button radio		OPT	OPT	OPT	OPT
AM/FM Push Button radio/stereo cassette player	(a)	OPT	OPT	OPT	OPT
Centafold - front seat	(b)	OPT	OPT	STD	STD
Windscreens wipers with intermittent setting	(c)	OPT	OPT	OPT	OPT
Lift-up/drop-down tailgate		N/A	OPT	N/A	STD
Twin rear doors side hinged		N/A	STD	N/A	ORC
Van side glass		N/A	OPT	N/A	STD
Deleke Van side glass		N/A	STD	N/A	ORC
Tonneau Cover (Bang - cord type)		OPT	N/A	STD	N/A
Tinted hand laminated windscreen		OPT	OPT	OPT	OPT

Sports-Type

S-Pack	(b)(c)	N/A	N/A	OPT	OPT
Alloy road wheels		OPT	OPT	OPT	OPT
Limited slip differential	(d)	OPT	OPT	OPT	OPT
Striped wool blend cloth seat facings	(c)	N/A	N/A	OPT	OPT

Power

Power steering	(e)	OPT	OPT	OPT	OPT
----------------	-----	-----	-----	-----	-----

Other Packs

Outback Pack	(f)	OPT	OPT	OPT	OPT
Class I Towing Pack	(g)	OPT	OPT	OPT	OPT

Appearance

Metallic Paint	(h)	OPT	OPT	OPT	OPT
----------------	-----	-----	-----	-----	-----

Engine/Transmission Combinations

Engine	Transmission	Notes	Ute	Falcon Van	Falcon GL Ute	Falcon GL Van
3.3 litre	3-speed manual column shift	1	STD	STD	N/A	N/A
Alloy Head II	Column automatic		OPT	OPT	N/A	N/A
4.1 litre	3-speed manual column shift	1	OPT	OPT	STD	STD
Alloy Head II	4-speed manual floor shift	2	N/A	N/A	OPT	OPT
	Column automatic		OPT	OPT	OPT	OPT
	T-Bar automatic	2	N/A	N/A	OPT	OPT

Tyre Availability

ER78S14 steel belt radial ply tyres	STD
ER70H14 steel belt radial ply tyres	OPT (Standard with S-Pack option).

OPT - Optional at extra cost. STD - Standard Equipment. N/A - not available. ORC - optional at reduced cost.

About this Specification Sheet. This sheet is designed to provide you with selected specification data for the Ford Products which have been described in a general way in the relevant brochure. Because of changes in conditions and circumstances Ford* reserves the right, subject to all applicable laws, at any time, at their discretion, and without notice to discontinue or change the features, designs, materials, colours and other specifications and the prices of their products, and to either permanently or temporarily withdraw any such products from the market without incurring any liability to any prospective purchaser or purchaser.

Because of variations which occur in manufactured products, all capacities, measurements, dimensions and weights quoted in the relevant brochure and this specification sheet should be taken as approximate only.

Always consult an Authorised Ford Dealer for the latest information with respect to features, specifications, prices, optional equipment and availability before deciding to place an order.

* FORD MOTOR COMPANY OF AUSTRALIA LIMITED
FORD SALES COMPANY OF AUSTRALIA LIMITED
1735 SYDNEY ROAD, CAMPBELLFIELD, VICTORIA, 3061.

Notes

- AM/FM push button radio/stereo cassette player includes two speakers on Utes and four speakers on Vans.
- Centafold (front seat) is standard on Falcon GL, Utes and Vans fitted with a column shift transmission. Centafold is not available when a floor shift transmission, or the S-Pack option, is specified. See note 2 below.
- The S-Pack option includes:
 - Fog lamps
 - Front spoiler
 - Destructive paint/strip treatment
 - Striped wool blend cloth seat facings
 - LED digital clock
 - Windscreens wiper with intermittent setting
 - Comprehensive instrumentation
 - ER70H14 steel belt radial ply tyres
 - Styled steel wheels with chromed trim rings
 - An Econoquage is not fitted when the S-Pack is specified
 - Comprehensive instrumentation consists of:
 - Speedometer
 - Tachometer
 - Fuel Gauge
 - Temperature gauge
 - Oil pressure gauge
 - Volt meter
 - Temp meter
 - Low fuel warning lamp
 - An Econoquage is not included
- Limited slip differential is only available when a 4.1 litre Alloy Head II engine is specified in conjunction with an automatic or a floor mounted manual transmission.
- Power steering is not available on vehicles fitted with a 3-speed column shift manual transmission.
- The Outback Pack option consists of:
 - Heavy duty air cleaner
 - Engine sump guard
- The Class I Towing Pack is designed to provide a towing capability for loads with a gross weight of up to 900 kg. (1985 lbs) when used in conjunction with a suitable caravan or trailer braking system and towing equipment. The Pack consists of:
 - Tow bar
 - Crossneck
 - Wiring harness with 7 pin electrical connector

Note: The Caravan or trailer braking system any other items (such as the tow ball and safety chains) required for the attachment of a trailer, caravan or the like to the vehicle are not supplied as part of the Pack, and must be purchased at extra cost or be supplied by the purchaser of the vehicle.

The Class I Towing Pack is designed to be incorporated in the vehicle during the assembly of the vehicle. The actual towing capability and performance of a vehicle will depend upon many factors including the suitability of the caravan, trailer etc, the condition of the vehicle, the vehicle load, the vehicle specification (including engine capacity, transmission type, axle ratio, tyre type and size), weather conditions, road gradient, terrain and other prevailing conditions.

(h) Some colours are not available in metallic paint. Consult the Ford Colour Selector or your Authorised Ford Dealer to determine which colours are available in metallic paint.

- Power steering is not available with a 3-speed manual column shift transmission.
- Centafold (front seat) is standard on Falcon GL, Utes and Vans fitted with a column shift transmission and is not available when a floor shift transmission is specified.

TOWING PACK AVAILABILITY

The Class I Towing Pack, available as a factory fitted option, has a towing capability for loads with a gross weight of up to 900 kgs.

The following Towing Packs are available for fitment as accessories from your Authorised Ford Dealer.

• Class I Towing Pack - For manual transmission vehicles, which has a towing capability for loads with a gross weight of up to 900 kgs.

- For automatic transmission vehicles, which has a towing capacity for loads with a gross weight of up to 500 kgs. - A Ford approved transmission oil cooler must be fitted if the owner wishes to tow a gross weight of up to 900 kgs.

• Class II Towing Pack - Which has a towing capability for loads with a gross weight of up to 1500 kgs.

Consult your Authorised Ford Dealer for the latest information with respect to the specifications of the items included in, and the availability of these accessory towing packs.

Some options are required to be ordered or used in combination with other options. Please consult the notes to the tables and your Authorised Ford Dealer for details of these matters and correct operation of optional equipment before deciding to place your order.



Ford Australia - We're moving with you.



Printed February 1982