

New Ford F-Series. Pours on the power.



To Sunday.

When you're ready for some heavy fun, the new F-Series is ready to go with the most powerful engine of any 1 tonne truck in Australia. So when you hitch up your boat or caravan and head for the wide open spaces, you do it with wide open confidence.



Fuel Injected V8.

The new F-Series comes equipped with Ford's proven 5 litre, electronically fuel injected V8. This powerplant pumps out a hefty 126kW @ 4000rpm and 358Nm of torque @ 2500rpm. And when you run that sort of power through a 4-speed manual gearbox or optional 3-speed automatic, and a

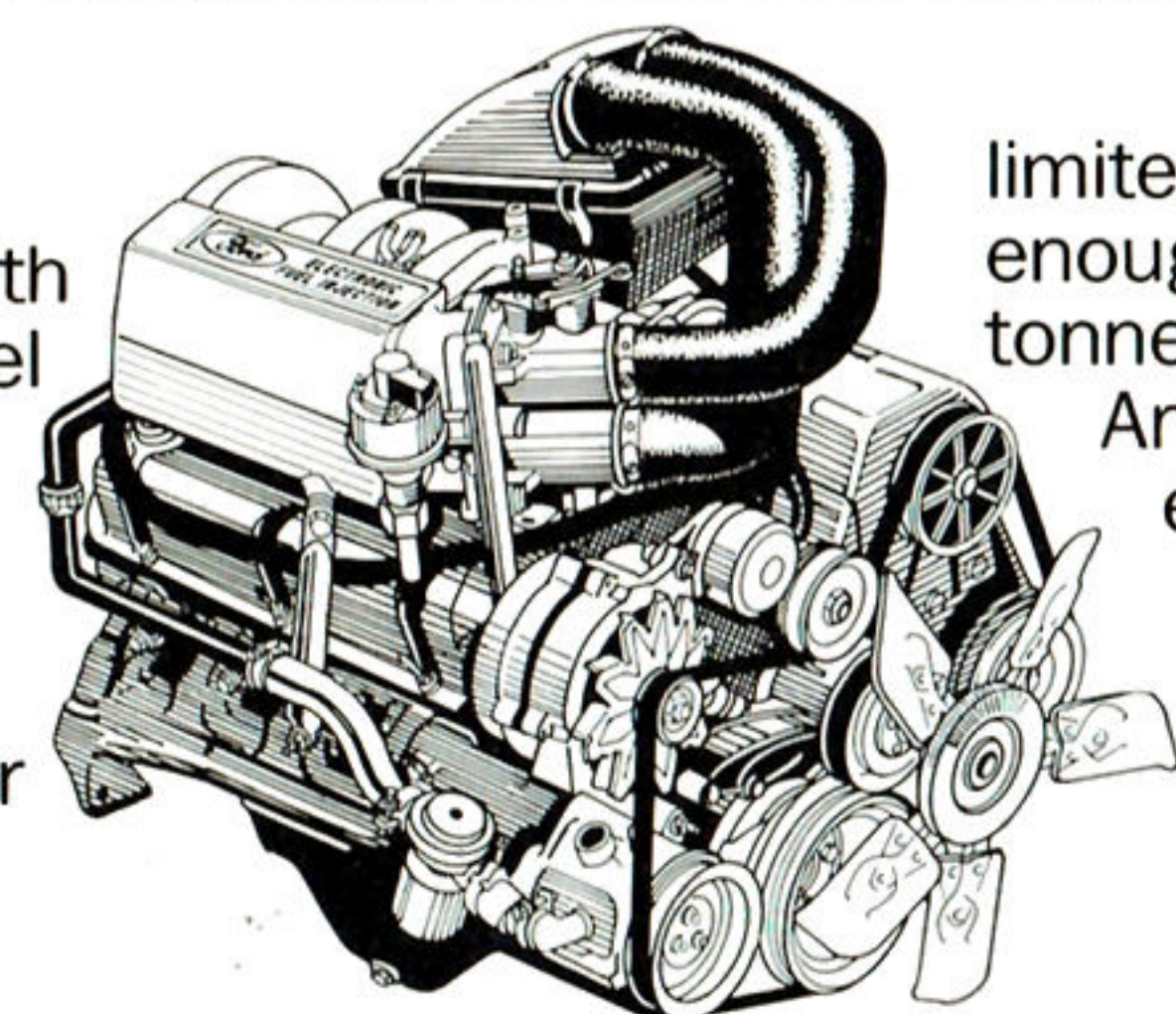

limited slip diff, you've got more than enough muscle to move up to a full 1-tonne payload. Or tow up to 2270 kgs. And because the engine is electronically fuel injected, you get the benefits of efficient overall operation, smooth running and easier starting in extremes of temperature.

Roomy comfortable interior.

Outside, this truck is stylish and good looking. Inside, room and comfort is the name of the game. The 3-across bench seat provides firm yet comfortable support. Behind the new steering wheel there's a full complement of gauges and warning lights. While the AM/FM stereo radio and climate controls are conveniently located within easy reach of both you and your passengers.



Relaxed ride and handling.

To further enhance the F-Series' already renowned ride and handling, power steering and gas pressurised shock absorbers are fitted across the range. And when it comes to noise and vibration levels, the F-Series is exceptionally quiet thanks to modifications to the exhaust system, engine and chassis mounts.

Monday.

Ready. Willing. And hungry for work.

Every model in the F-Series range is built Ford tough to do the job right—4 x 2 and 4 x 4 chassis cab and pick-up, plus the luxury XLT 4 x 2 and 4 x 4 pickups. On pick-ups there's a big cargo bed that can hold a stack of gear. Inside the roomy cab, comfort is the name of the game.

While up front there's the brute strength of a V8 to put you in charge.



Fuel Injected V8.

The new F-Series comes equipped with Ford's proven 5 litre, electronically fuel injected V8. This powerplant pumps out a hefty 126 kW @ 4000 rpm and 358 Nm of torque @ 2500 rpm. And when you run that sort of power through a 4-speed manual gearbox or optional 3-speed automatic, and a

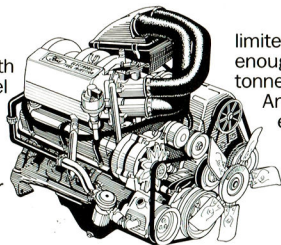

limited slip diff, you've got more than enough muscle to move up to a full 1-tonne payload. Or tow up to 2270 kgs.

And because the engine is electronically fuel injected, you get the benefits of efficient overall operation, smooth running and easier starting in extremes of temperature.

Modern styling.

Whether you're on the job or out on the town, the stylish aerodynamic lines of the new F-Series will turn heads. And to make the new F-Series XLT models even more distinctive, there's a new range of 2-tone exterior colour combinations available at extra cost.

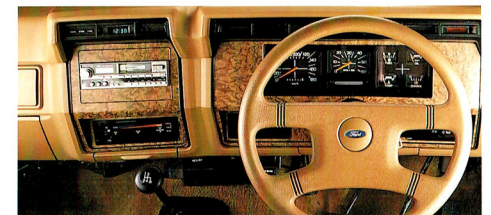

Monday.

Ready. Willing. And hungry for work.

Every model in the F-Series range is built Ford tough to do the job right—4x2 and 4x4 chassis cab and pick-up, plus the luxury XLT 4x2 and 4x4 pickups. On pick-ups there's a big cargo bed that can hold a stack of gear. Inside the roomy cab, comfort is the name of the game.

While up front there's the brute strength of a V8 to put you in charge.



Modern styling.

Whether you're on the job or out on the town, the stylish aerodynamic lines of the new F-Series will turn heads. And to make the new F-Series XLT models even more distinctive, there's a new range of 2-tone exterior colour combinations available at extra cost.

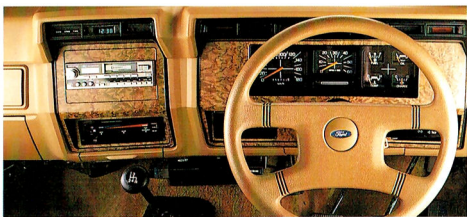

Rear anti-lock brakes for smooth, straight stopping.

To help you stop smoothly without the drama of rear wheel lock-up, rear anti-lock brakes are now standard equipment across the F-Series range.

One tough line-up that's tough to beat.

When we say the new F-Series is built Ford tough, we mean it. Double-wall-tough tailgate and

side panels are all standard. As is a strong ladder frame chassis. To smooth out the roughest roads, there's the rugged Twin-Beam front suspension. And, 4 x 4 models have all-terrain steel belted radials as standard.

Twin petrol tanks operated by a single switch from inside the cab let you travel longer distances with fewer stops for fuel. And with the new F-Series, Ford gives you a range of trucks to choose from.

For specific details contact your Ford Dealer.



See Your Local Ford Dealer:

About this brochure. This brochure is designed to provide you with a general introduction to the Ford Products (including available optional equipment) referred to, and should be read in conjunction with the latest specification sheets. Because of changes in conditions and circumstances Ford* reserves the right, subject to all applicable laws, at any time, at its discretion, and without notice to discontinue or change the features, designs, materials, colours and other specifications and the prices of its products, and to either permanently or temporarily withdraw any such products from the market without incurring any liability to any

prospective purchaser or purchaser.

The latest specification sheet should be referred to for information on the availability, ordering and use of optional equipment. Always consult an Authorised Ford Dealer for the latest information with respect to features, specifications, prices, optional equipment and availability before deciding to place an order.

*FORD MOTOR COMPANY OF AUSTRALIA LTD.

(Incorporated in Victoria)

Registered Office: 1735 Sydney Road, Campbellfield, Victoria 3061.

Printed September, 1987.

New Ford F-Series. Pours on the power.



Monday.

Ready. Willing. And hungry for work.

Every model in the F-Series range is built Ford tough to do the job right—4x2 and 4x4 chassis cab and pick-up, plus the luxury XLT 4x2 and 4x4 pickups. On pick-ups there's a big cargo bed that can hold a stack of gear. Inside the roomy cab, comfort is the name of the game.

While up front there's the brute strength of a V8 to put you in charge.



Modern styling.

Whether you're on the job or out on the town, the stylish aerodynamic lines of the new F-Series will turn heads. And to make the new F-Series XLT models even more distinctive, there's a new range of 2-tone exterior colour combinations available at extra cost.

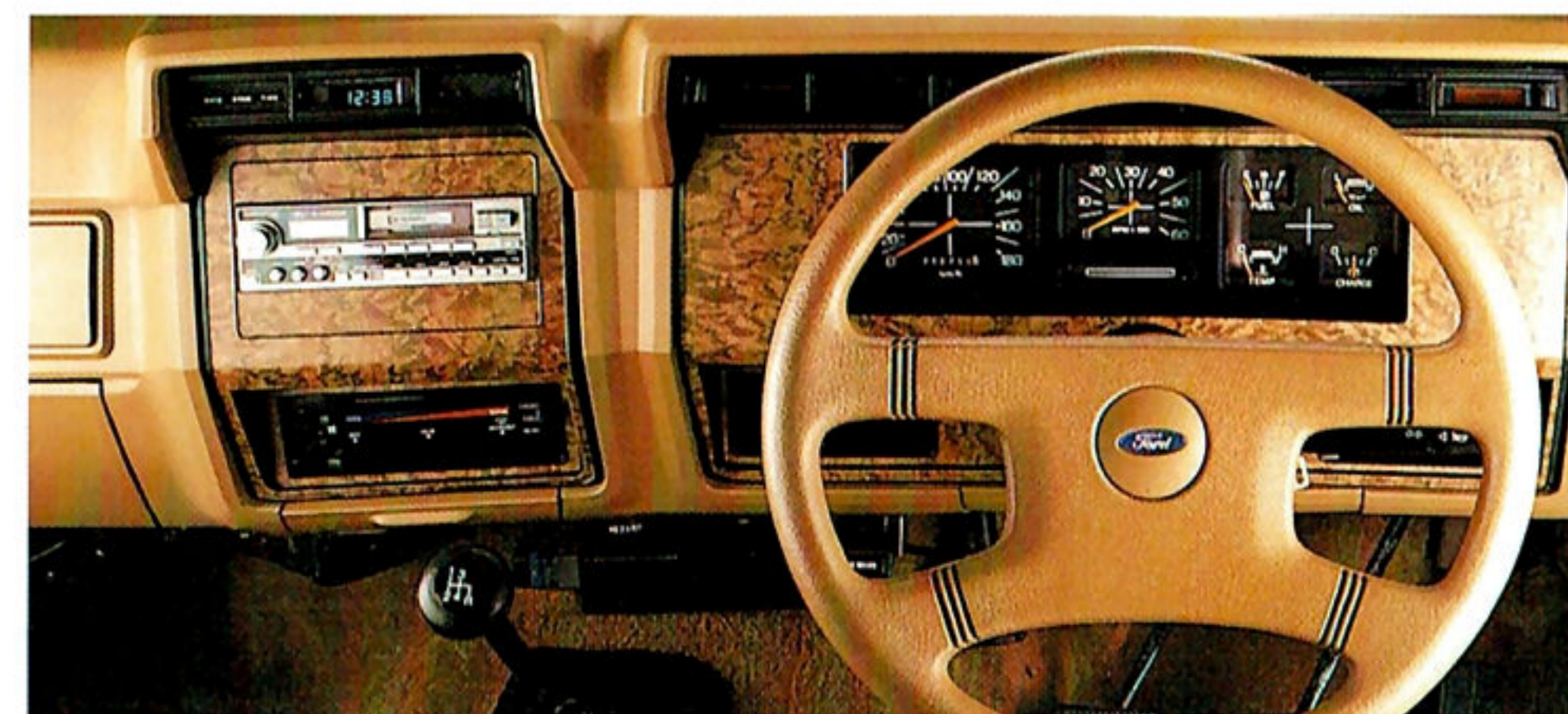

Rear anti-lock brakes for smooth, straight stopping.

To help you stop smoothly without the drama of rear wheel lock-up, rear anti-lock brakes are now standard equipment across the F-Series range.

One tough line-up that's tough to beat.

When we say the new F-Series is built Ford tough, we mean it. Double-wall-tough tailgate and



side panels are all standard. As is a strong ladder frame chassis. To smooth out the roughest roads, there's the rugged Twin-I-Beam front suspension. And, 4x4 models have all-terrain steel belted radials as standard.

Twin petrol tanks operated by a single switch from inside the cab let you travel longer distances with fewer stops for fuel. And with the new F-Series, Ford gives you a range of trucks to choose from.

For specific details contact your Ford Dealer.

See Your Local Ford Dealer:

About this brochure. This brochure is designed to provide you with a general introduction to the Ford Products (including available optional equipment) referred to, and should be read in conjunction with the latest specification sheets. Because of changes in conditions and circumstances Ford* reserves the right, subject to all applicable laws, at any time, at its discretion, and without notice to discontinue or change the features, designs, materials, colours and other specifications and the prices of its products, and to either permanently or temporarily withdraw any such products from the market without incurring any liability to any

prospective purchaser or purchaser. The latest specification sheet should be referred to for information on the availability, ordering and use of optional equipment. Always consult an Authorised Ford Dealer for the latest information with respect to features, specifications, prices, optional equipment and availability before deciding to place an order.
*FORD MOTOR COMPANY OF AUSTRALIA LTD.
(Incorporated in Victoria)
Registered Office: 1735 Sydney Road, Campbellfield, Victoria 3061.

Printed September, 1987.

New Ford F-Series. Pours on the power.



New Ford F-Series. Pours on the power.



To Sunday.

When you're ready for some heavy fun, the new F-Series is ready to go with the most powerful engine of any 1 tonne truck in Australia. So when you hitch up your boat or caravan and head for the wide open spaces, you do it with wide open confidence.



Fuel Injected V8.

The new F-Series comes equipped with Ford's proven 5 litre, electronically fuel injected V8. This powerplant pumps out a hefty 126kW @ 4000rpm and 358Nm of torque @ 2500rpm. And when you run that sort of power through a 4-speed manual gearbox or optional 3-speed automatic, and a

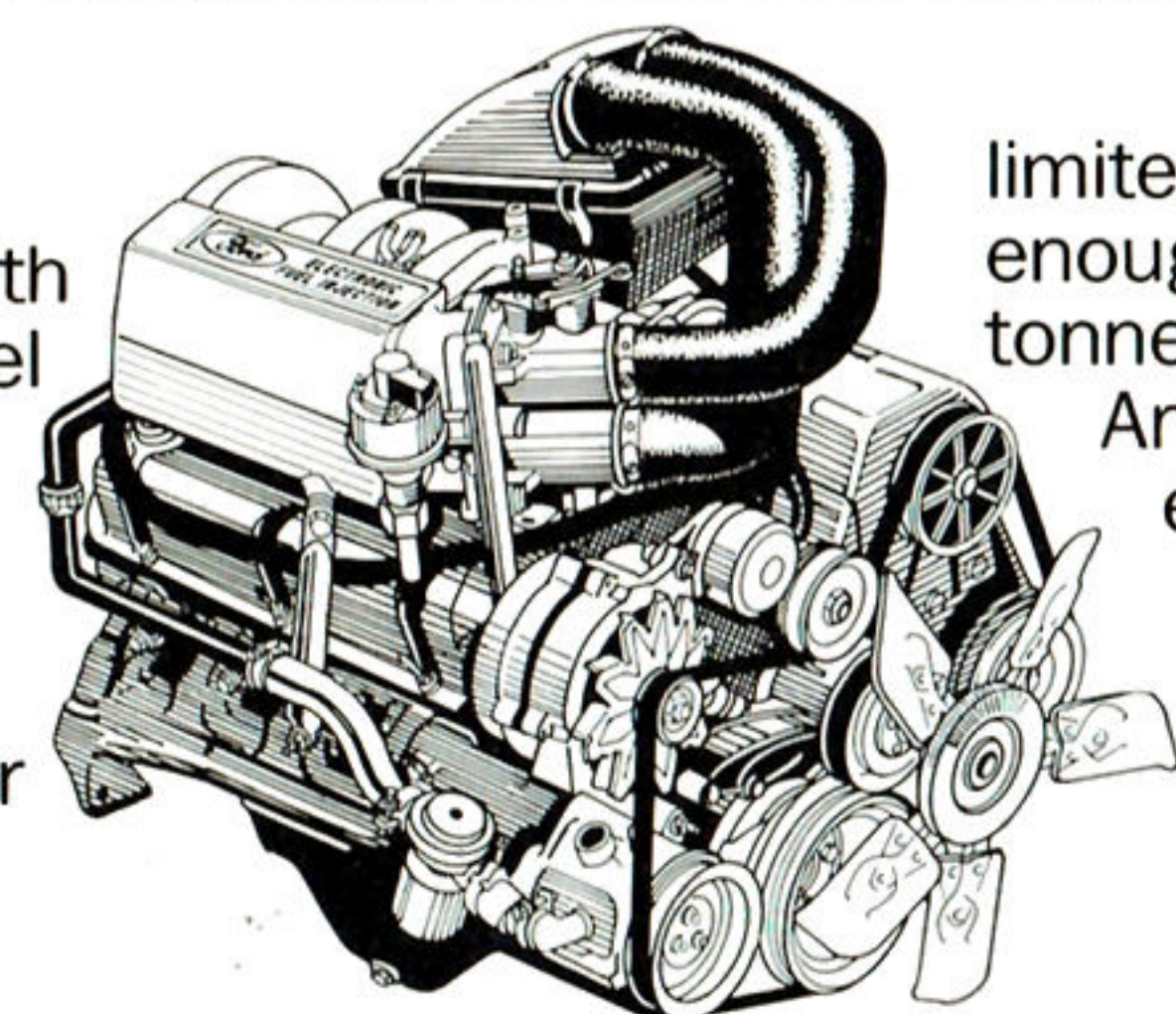

limited slip diff, you've got more than enough muscle to move up to a full 1-tonne payload. Or tow up to 2270 kgs. And because the engine is electronically fuel injected, you get the benefits of efficient overall operation, smooth running and easier starting in extremes of temperature.

Roomy comfortable interior.

Outside, this truck is stylish and good looking. Inside, room and comfort is the name of the game. The 3-across bench seat provides firm yet comfortable support. Behind the new steering wheel there's a full complement of gauges and warning lights. While the AM/FM stereo radio and climate controls are conveniently located within easy reach of both you and your passengers.



Relaxed ride and handling.

To further enhance the F-Series' already renowned ride and handling, power steering and gas pressurised shock absorbers are fitted across the range. And when it comes to noise and vibration levels, the F-Series is exceptionally quiet thanks to modifications to the exhaust system, engine and chassis mounts.