

FORD FALCON GL SEDAN & WAGON



A legend on the move.

New Ford Falcon GL sedan and wagon. Vehicles which represent the high standard of Australian automotive technical know-how and engineering expertise.

Designed and developed to provide comfort, durability and economy to meet the exacting demands of Australian conditions.

With a body line that's aerodynamically efficient, elegant and gracefully smooth. With the power and features to take you across town or across Australia with style and ease.

And now, as the latest step in the continuing process of change and improvement, there's the ease of power steering and the stopping power of 4-wheel disc brakes - as standard equipment.

These features add to the attributes that have combined to make Falcon Australia's favourite family car. Another chapter in a process of evolution that has made Ford Falcon a legend on the move.



The Legend.

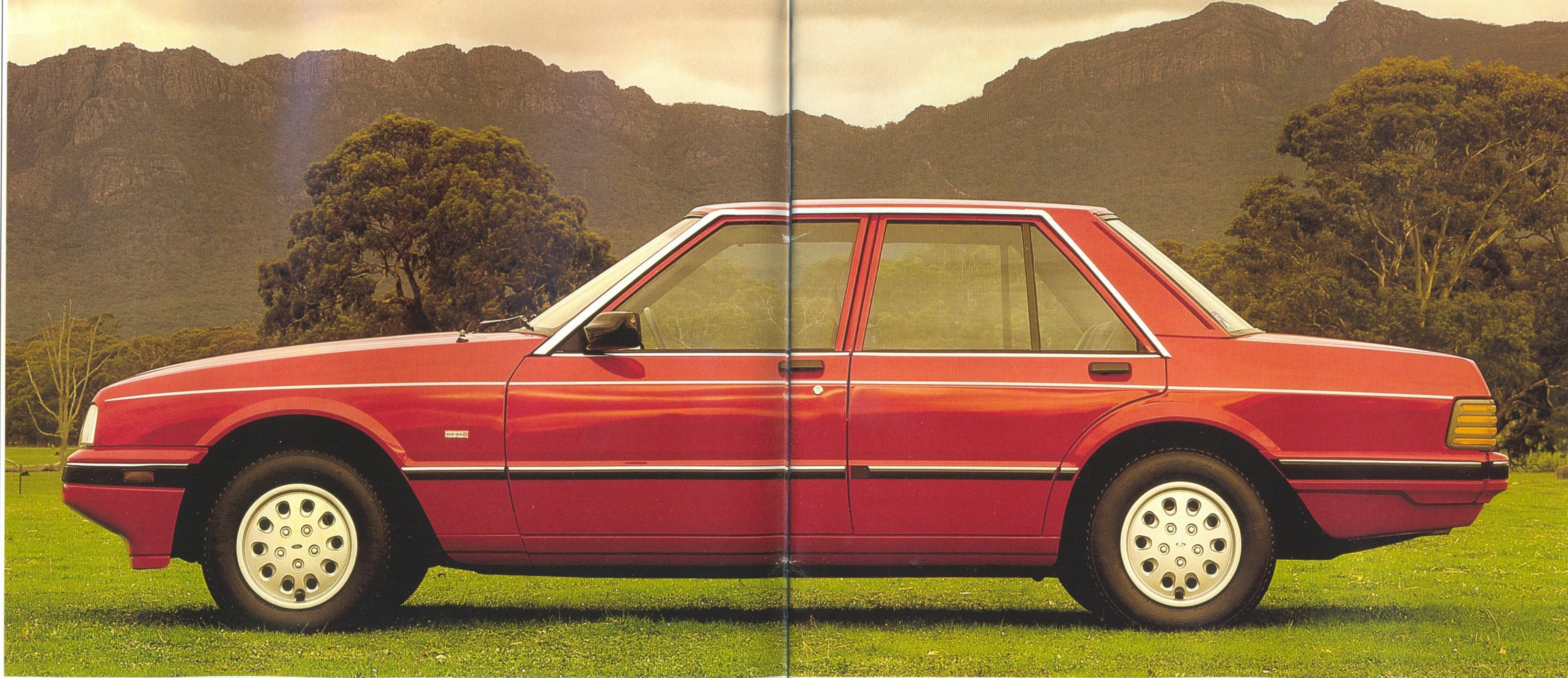

The Style.

Relax into the most spacious motoring environment in its class. Stretch out in a cabin that really gives you room to move, where slim pillars give you an "open" feeling with excellent vision.

Note the large dimensions which offer comfortable five or six seat accommodation, with ample head, shoulder and leg room.

A thoughtful level of colour co-ordination throughout with a fascia, 4-spoke steering wheel and moulded door panels in tones that blend with the loop pile carpeting and plush new herringbone seat facings.

In the sedan rear seat, a unique fold-down centre section forms a wide convenient tray while leaving an opening to the boot - an opening which lets you carry long, otherwise awkward objects.

Temperature and directional controls are rotation type switches, which are clearly identified and easy to operate. Flow-through ventilation



provides a high volume of fresh air into the cabin for occupant comfort, while the effective heating system incorporates a range of distribution modes depending on individual requirements. A 4-speed fan controls the output volume.

Falcon's standard push-button AM/FM radio cassette player fills your mobile environment with the sound of your favourite tapes, or at the touch of a button, keeps you in tune with the outside world.

And Falcon has other thoughtful touches like a glove box that is wide and deep enough to be really useful and a centre console with storage room for coins, sunglasses and cassettes.

Add tinted side and rear glass, a tinted band laminated windscreen and instruments and controls arranged for your comfort and convenience and you have an interior that makes Falcon the ideal driving environment for Australia.

The Comfort.

One glance at the stylish dash in Falcon GL tells you that this is a vehicle designed for ease of control.

An instrument cluster that features an electronically-driven speedometer, with tripmeter, plus fuel and temperature gauges to keep you constantly informed.

A digital clock with variable brightness is placed right in front of the driver to help ensure those important appointments are kept right on time.

Two banks of large, easy-to-use switches surround the instrument cluster, all within easy reach of the soft feel steering wheel for operation with minimum disruption to the driver's concentration.

There are efficient twin column stalks which operate windscreen wiper and washer switch, turn indicators, horn and headlights dipping - all designed for swift fingertip operation.

An illuminated ignition lock affords easy operation in the dark.

Falcon GL is designed to keep you in control.



Falcon GL shown with optional five-speed manual transmission and air-conditioning.

The Control.



With its long wheelbase and wide track, Falcon provides excellent road holding and stability on Australia's diverse road surfaces.

Now, Falcon's driving qualities take on a new dimension with the addition of power steering as standard equipment.

With only 2.5 turns lock to lock, Falcon's recirculating ball power steering provides easy low speed manoeuvrability and parking, while maintaining good on-road "feel" for the highway.

Power assisted 4-wheel disc brakes are another standard feature of today's Falcon, designed to provide security and stopping power with only light pedal pressure.

Two further improvements that add even more ease, control and driving pleasure to Australia's number one selling sedan and wagon.

The Response.



Dynamic styling has given the Falcon GL wagon an impressive difference. Up front the look is sleek. The quartz halogen headlights and driving lights are integrated within the total design.

High-strength polymer bumpers are styled to neatly wrap around front and rear which helps protect against minor impacts. The front bumper and grille are now colour keyed to the body.

And, as with the Falcon GL sedan, you'll note the wide bodyside protection mouldings and distinctive pinstriping.

But of course, it's the extra space you buy a wagon for. So open up Falcon's tailgate and check out the cargo area.

No other Australian wagon gives you more loadspace.

The Versatility.

A huge carpeted floor gives room for luggage, sports gear and a variety of other items. By folding down the rear seat back, the load floor is extended to almost 2 metres in length for bulky items, or even for stretching out to sleep.

The tailgate has a hard-working washer-wiper system to give you clear rear visibility. The tailgate is supported by strong dual gas struts so you can lift it with ease.

You'll appreciate the other Falcon standards, too. Big supportive seats faced in herringbone cloth. Tasteful color co-ordination with fascia, moulded door panels and carpeting all in harmony. An inviting environment for driver and passengers alike.

For even greater versatility there's the option of the unique Centafold* front seat (refer option section) instead of the standard bucket seats. With the flip of an armrest, you have an extra backrest and front seating for three.

It all adds up to real wagon versatility, Ford style.

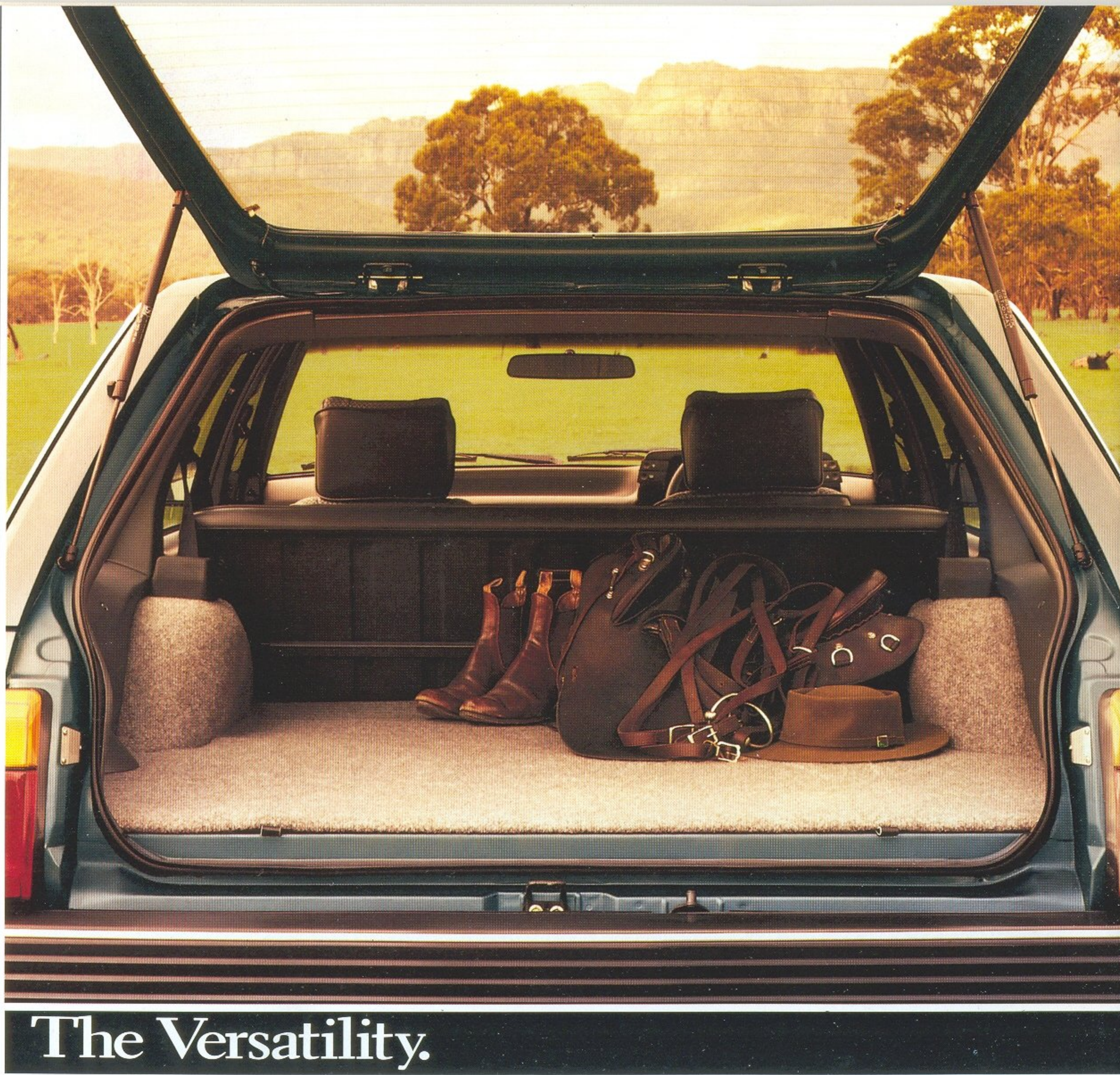

The Versatility.

The Performance.

Ford Falcon gives you a choice of three responsive six-cylinder engines.

The rugged, economical 3.3 litre Alloy Head II engine has the reliability that Falcon is famous for, and is fitted as standard equipment.

If you need more power, you can select, at extra cost, Falcon's 4.1 litre, or 4.1 litre EFI engine; the latter is controlled by the advanced EEC4 micro-computer system.



Each Ford 6-cylinder engine develops high torque over a broad range of engine speeds, so you can expect smooth response and excellent highway performance.

Specially modified to operate on unleaded fuel with performance and economy in mind, these engines feature a revised combustion chamber shape, piston ring and valve stem seal designs and a camshaft with a higher lift.

EEC4 (Electronic Engine Control) is an on-board digital microcomputer which monitors and controls a number of vital engine functions including air flow, fuel flow and spark timing.

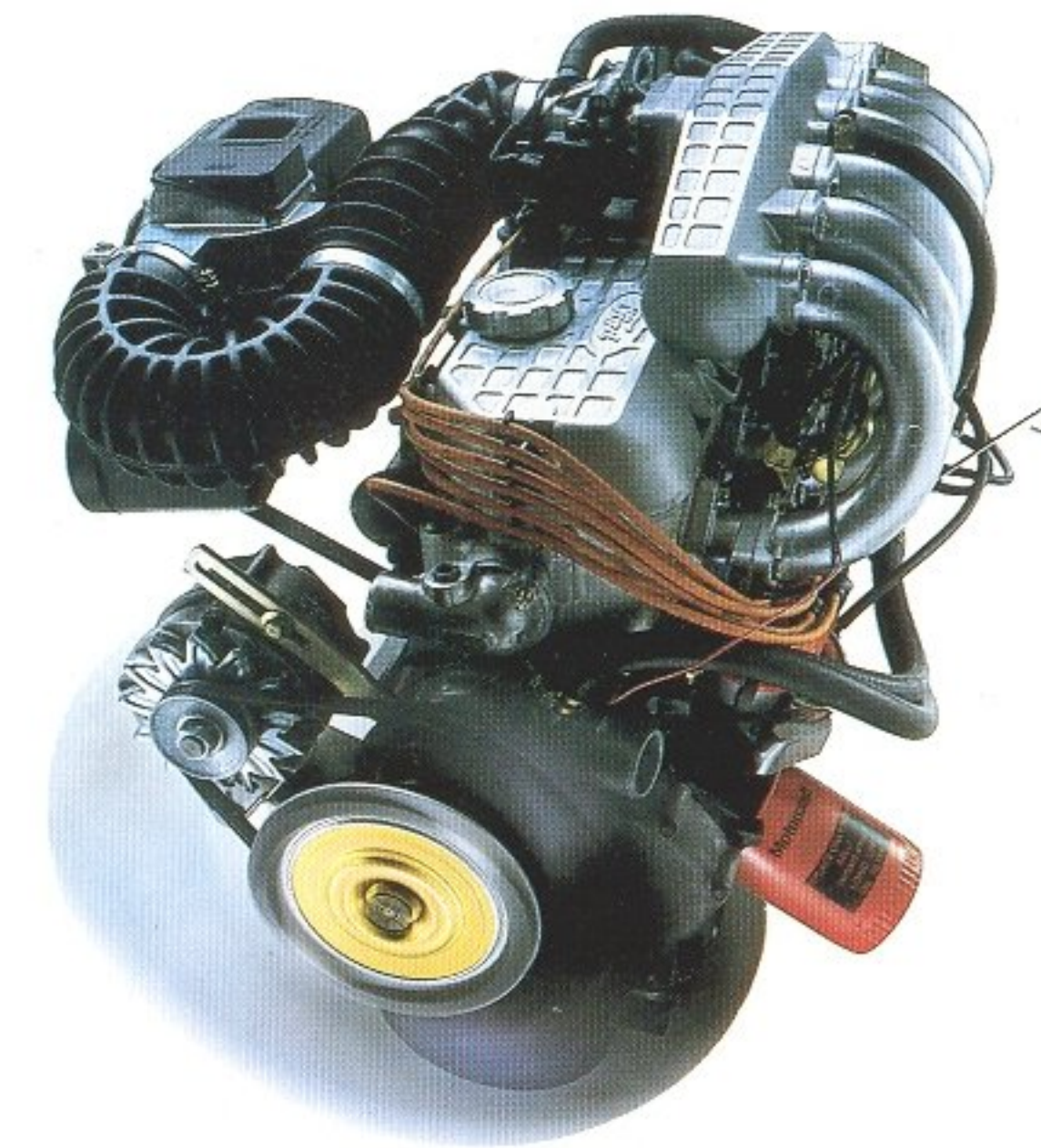

It also provides an "interactive spark strategy" in response to engine load, speed, temperature and time from start-up. The benefits of this computer control system show up in the control of performance, engine running, reliability and economy. And since the EEC4 can interface with modern diagnostic



servicing equipment, servicing with that equipment becomes faster and more efficient.

Falcon sedans incorporate the proven Watts Link rear suspension system to give you excellent road holding and stability. Even while cornering or towing, Falcon keeps you in firm touch with the road and provides a smooth comfortable ride on most road surfaces.

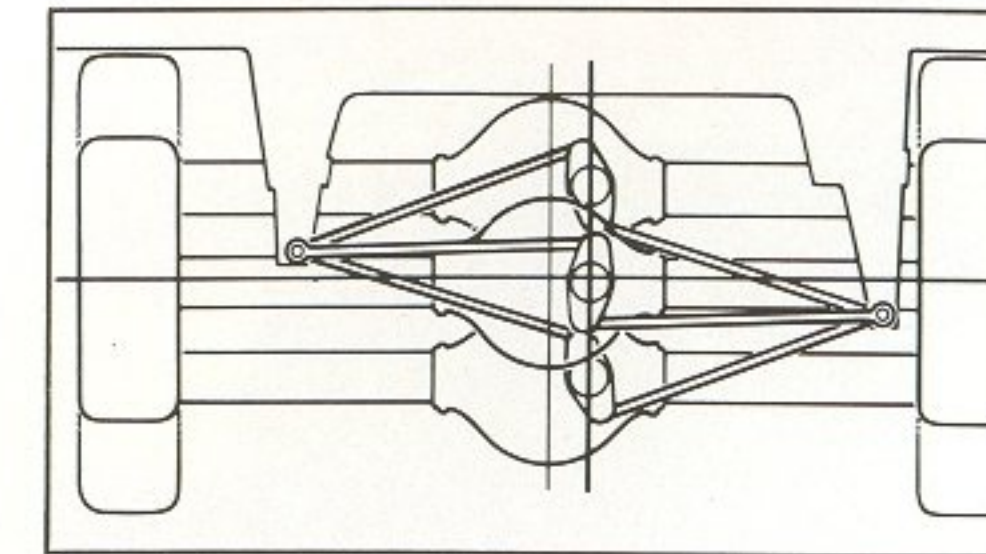

A 4-speed manual floor shift transmission is standard.

Or at extra cost, you can team your choice of engine with a smooth 3-speed T-bar automatic, or 5-speed manual floor shift.

If you drive long distances, you'll especially appreciate the benefits of the tall-g geared 5-speed manual transmission which assists fuel economy.

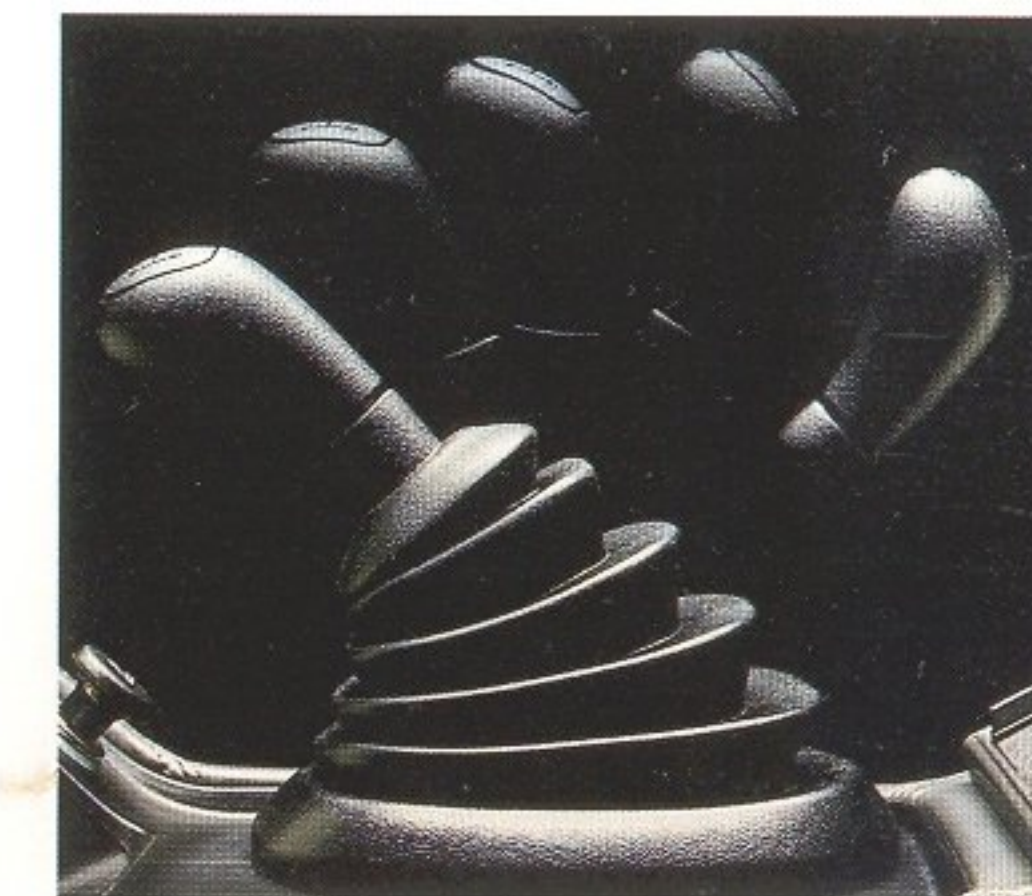

Falcon's 'S' Pack option gives you the freedom to express your individuality. For those who like a sporty difference, the 'S' Pack features:

- Racy Black body stripes.
- Fog lamps.
- Styled steel wheels.
- Distinctive trim rings.
- Steering column rake adjustment.
- Adjustable lumbar support for the driver.
- Driver's seat tilt.
- Driver's footrest.
- Red 'Falcon' and 'S' badge at rear.
- Sporty tweed fabric facings with thick inserts on the seats.
- A sports instrument cluster which features an electronic vacuum fluorescent display, with speedometer, tachometer, and dual bar graphs, incorporating a digital clock. These graphs display water temper-



ature and fuel level or, at the press of a button, oil pressure and battery voltage. The display is controlled by a microprocessor which monitors, updates and indicates any malfunction in those systems.



The Individuality.

The Options.

Ford offers a wide range of extra cost options to add even more convenience and pleasure to the Falcon of your choice.

Air Conditioning

Ford's exclusive factory-fitted air conditioning is designed for rapid heat "pull down" under severe Australian conditions as well as efficient demisting. In all Falcon models with floor mounted transmissions, the system includes ducting, with directional control, to provide cool air to rear seat passengers.



Centafold Seat *

If you need your Falcon GL to take six passengers, specify the Centafold front seat instead of the standard

bucket seats, and with the flip of an armrest, you have an extra backrest and front seating for three.

The Centafold seat is only available with a column shift transmission, and is not available when the 'S' Pack option is specified.



Towing Pack

The towing pack is a specially designed and factory-fitted

option and provides a towing capacity of 1200kgs for 4.1 litre vehicles, or 910kgs for 3.3 litre vehicles.

The option includes a painted gooseneck and 7-pin trailer wiring connection.

Alloy Wheels

Smart, modern "spoked" design alloy wheels complement Falcon's good looks, and add style and value.

Heavy Duty Suspension

For extensive country travel, the Ford Heavy Duty Suspension option can be a wise investment. It consists of heavy duty springs, increased ride height and heavy duty shock absorbers.

Sports Handling Suspension

Falcon offers this special option for the performance-minded driver. Featuring increased rate springs with a lower ride height, increased diameter front stabiliser bar, and Bilstein gas shock absorbers front and rear. Designed to improve handling and stability while maintaining ride quality.

FORD FALCON GL

SEDAN & WAGON



About this brochure. This brochure is designed to provide you with a general introduction to the Ford Products (including available optional equipment) referred to, and should be read in conjunction with the latest specification sheets. Because of changes in conditions and circumstances Ford* reserves the right, subject to all applicable laws, at any time, at its discretion, and without notice to discontinue or change the features, designs, materials, colours and other specifications and the prices of its products, and to either permanently or temporarily withdraw any such products from the market without incurring any liability to any purchaser or prospective purchaser.

 **Ford Australia-**
We're moving with you.

The latest specification sheet should be referred to for information on the availability, ordering and use of optional equipment. Always consult an Authorised Ford Dealer for the latest information with respect to features, specifications, prices, optional equipment and availability before deciding to place an order.

*FORD MOTOR COMPANY OF AUSTRALIA LTD.
(Incorporated in Victoria)
Registered Office: 1735 Sydney Road,
Campbellfield, Victoria. 3061.

PRINTED MARCH 1987

**FORD
FALCON**

