

ALL OF ZEPHYR'S FAMOUS PERFORMANCE PLUS LONG, WIDE 8 CWT. UTILITY SPACE —

Zephyr Coupe-Utility

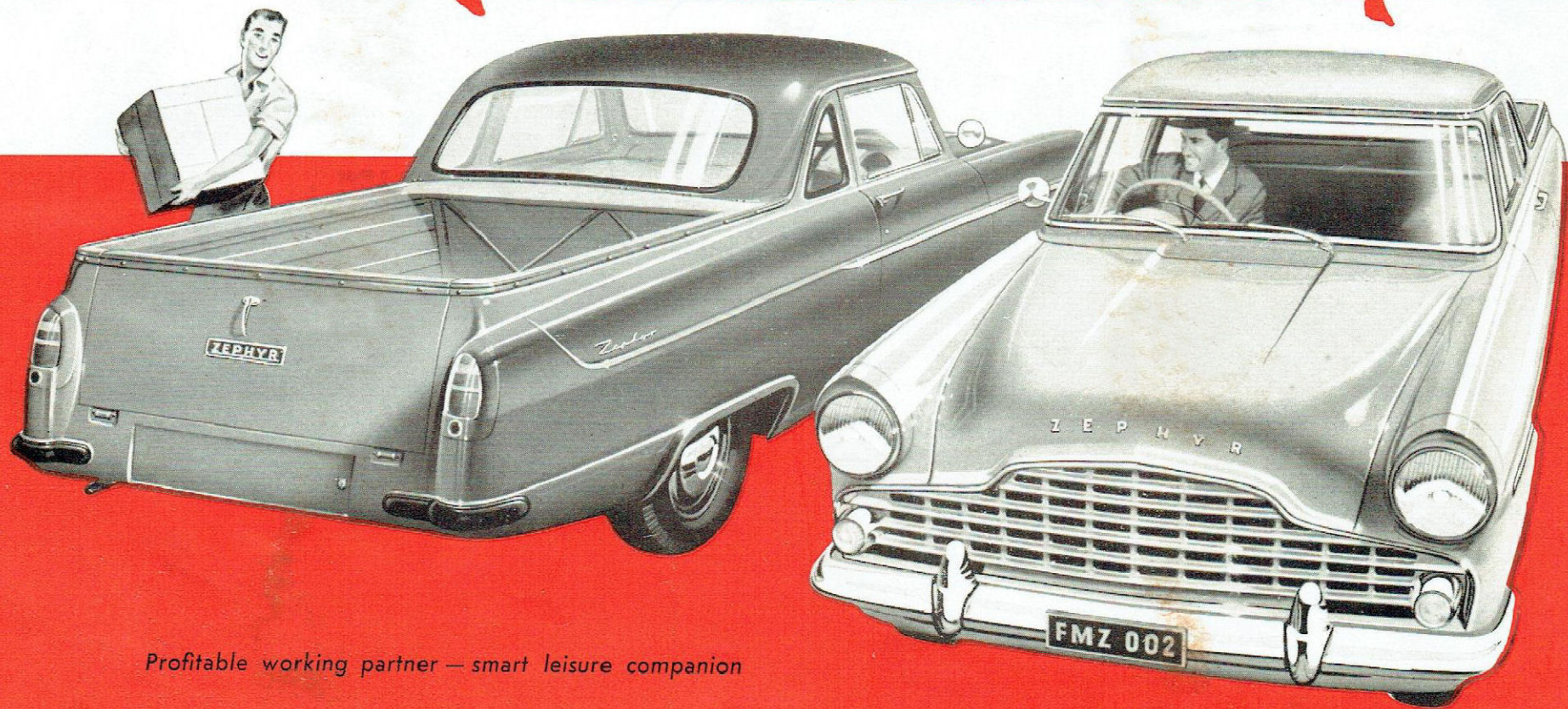

Profitable working partner — smart leisure companion

DESIGNED FOR TODAY'S INCREASING AND MORE VERSATILE USE OF COUPE UTILITIES . . .

from power to weight and load ratios to good looks . . .

Zephyr HAS MORE FOR WORK AND MORE FOR AFTER-WORK LEISURE

LATEST PRODUCT OF AUSTRALIA'S MOST EXPERIENCED BUILDER OF COUPE UTILITIES . . .

Ford-Australia designed the first coupe utility type of vehicle. Since then, the coupe utilities built by Ford have kept on bringing new advances. Here is the latest example of this continual progress — a balance of power, load-rating and overall weight which steps up efficiency in every purpose to which a coupe utility can be put. Styling and comfort, too, are outstanding. In personal car as well as working use, this Zephyr Coupe Utility brings you new and greater advantages.

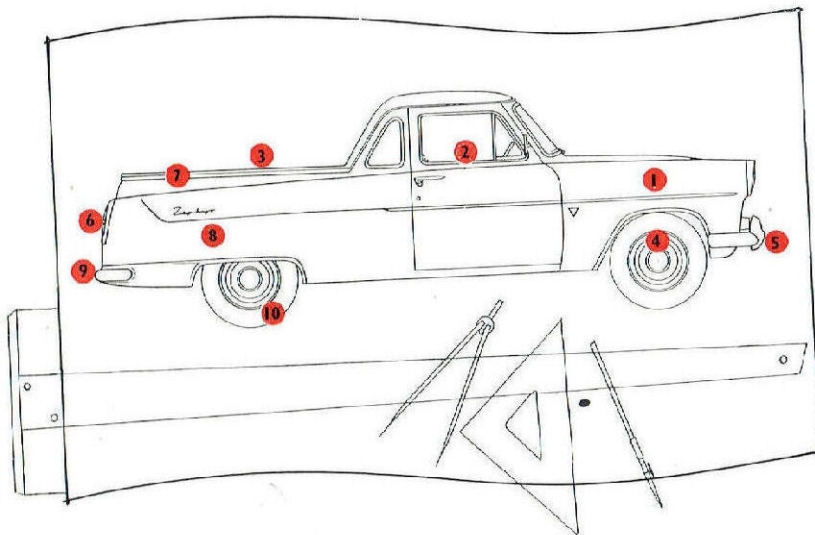

EVERY BASIC FEATURE MEANS A BASIC INCREASE IN COUPE UTILITY USEFULNESS

- (1) Zephyr 25.4 h.p. O.H.V. 6 cyl. engine — famous for extra, more flexible performance and greater life and smoothness of its over-square design.
- (2) Widespread interior comfort for three and wide-opening doors.
- (3) 8-cwt. load capacity in long, wide utility space.
- (4) Remarkable suspension system combining greater smoothness with road-hugging stability.
- (5) Wide front track and small turning circle of 36' for extra stability and manoeuvrability.
- (6) Wide-opening 48" tailgate which can form an extension of 96" length of load area.
- (7) Heavy duty steel strips on top of utility space panels for extra strength and to take loading stress.
- (8) Utility space sides are of double panels of husky steel with access ports for easy maintenance.
- (9) Separate, locking compartment for spare tyre under tailgate.
- (10) Heavy-duty, 6-ply 6-70 x 13 tyres on pressed steel wheels with wide-base rims.

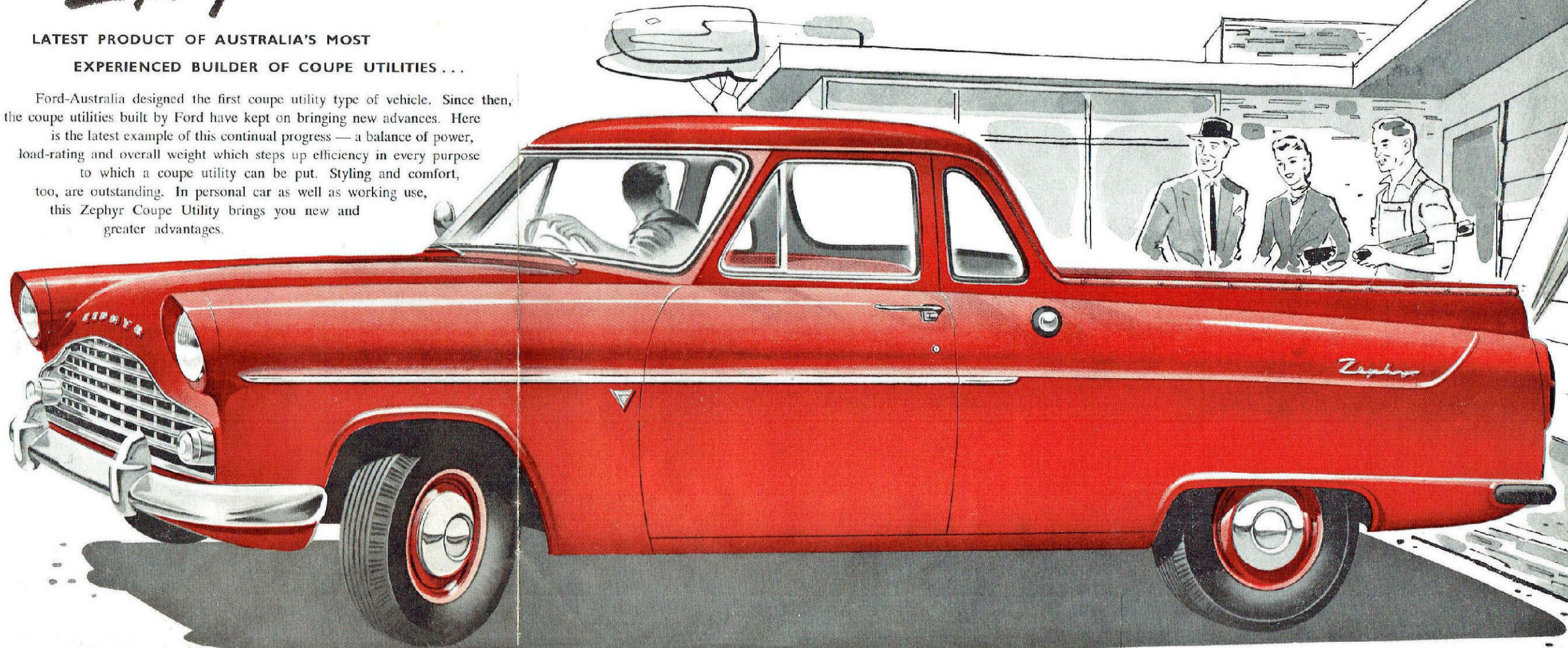

Specifications ZEPHYR COUPE-UTILITY

ENGINE: Six cylinder cast integrally with upper half of crankcase; bore 3.25 ins.; stroke 3.13 ins. Capacity 155.8 cu. ins. Overhead valves, push rod operated from harmonic cams in cylinder block. Compression ratio 6.9:1. B.H.P. 80 at 4,200 R.P.M. Torque 128 lbs./ft. at 2,000 R.P.M. Four bearing crankshaft with integral weights, dynamically balanced. Detachable cast-iron cylinder head incorporating volume controlled combustion chambers for economy and smooth running. Special autothermic alloy pistons. Three point suspension of engine and gear box giving remarkably smooth power flow.

ENGINE LUBRICATION: Pressure feed by submerged gear pump to crankshaft main bearings, big-end bearings and camshaft bearings via drillings in cylinder block and crankshaft. Full flow type oil filter fitted direct to cylinder block. Accessible dip stick and oil filter. Sump capacity with oil filter 8.5 pints.

IGNITION: 12 volt battery and coil (battery accessibly located under hood) — distributor has automatic advance and retard and additional vacuum control. Sparking plug size 14 mm. Firing order 1, 5, 3, 6, 2, 4.

FUEL SYSTEM: Diaphragm type fuel pump mechanically operated. Down draught carburettor has special choke control and is fitted with combined air cleaner and silencer. Electrical petrol gauge. Petrol tank capacity 11 gallons.

COOLING SYSTEM: Belt-driven fan and water pump with thermostatic heat control. Tube and fin type radiator. Capacity of system 22 pints.

TRANSMISSION: Clutch-dry single plate spring cushioned. Hydraulic operation from pedal to heavy duty, ball-bearing thrust release. Remote control of gears on steering column. Light action synchro-mesh on top and second gears. Helically cut constant mesh gears. Three forward speeds. Overall ratio — 3.90 to 1, 6.40 to 1, and 11.08 to 1. Reverse 15.06 to 1. Oil capacity of gearbox 2.5 pints approximately.

REAR AXLE: $\frac{3}{4}$ floating, hypoid final drive. Heavy duty roller and ball bearings. Open type drive shaft. Universal joints have needle roller bearings. Axle ratio — 3.90 to 1. Oil capacity 2½ pints approximately.

FRONT SUSPENSION: Independent front wheel suspension employs low periodicity coil springs mounted on special hydraulic double-acting telescopic shock absorbers integral with the wheel spindle assembly. The upper end of this unit rotates in an anti-friction bearing suspended in rubber and mounted on the body high inside wing valance. The base of the wheel assembly is connected via a ball jointed transverse track control arm to a tubular cross-member bolted to underside of the unitary body. An anti-roll torsion bar is fitted which, being triangulated, holds the track control arms in the fore and aft direction. The wide spacing and high location of the springs and shock absorbers, combined with accurately controlled geometry, give excellent riding and steering.

REAR SUSPENSION: Longitudinal semi-elliptic 9-leaf springs rubber insulated. Hydraulic double-acting shock absorbers.

BRAKES: Hydraulic internal — front 9 ins. x 2½ ins. Rear 9 ins. x 1¾ ins. Front — two leading shoes, rear — floating expander. Total lining area 147 sq. ins. Foot brake all four wheels, hand brake on rear wheels only.

STEERING: High efficiency worm and peg type. Ratio 16.8 to 1. Steering wheel diameter 17 ins. Two spoke safety type.

WHEELS AND TYRES: Pressed steel with wide base rims. Rustless steel hub-caps. Tyres 6.70 x 13 — 6 ply.

ELECTRICAL EQUIPMENT: Two-brush ventilated generator, compensated voltage control. Drive: "V" belt easily adjustable. Starter motor. Dual "Windtone" horns operated by horn ring on steering column. Battery: 12 volt 57 amp. hr. at 20 hr. rate.

INSTRUMENTS: Conveniently grouped cluster immediately in front of driver includes speedometer, fuel gauge, ammeter, oil

pressure warning light, direction indicator warning lights, ignition warning light, head-lamp main beam warning light. Instrument lighting controlled by tumbler switch on fascia panel.

CONTROLS: Choke, combined ignition-starter switch, lighting switch, instrument light and windshield wiper. Plastic control knobs. Foot operated head-lamp dimmer switch.

BODY: All-steel welded integral construction. Safety glass all round. Curved type fixed windscreen. Hinged no-draught ventilators embodied in front doors. Safety design push-button door handles. Adjustable, full-width tubular construction bench type seat. Washable vinyl headlining. Spare wheel housed in separate compartment beneath tailgate at rear.

GENERAL EQUIPMENT: Dual windscreen wipers operated from vacuum pump fitted on engine. Moisture-proof, flush fitting hooded headlamps. Separate side lamps. Tail and stop lamps combined. Rear number plate illumination lamps. Interior light. Sun visors. Doors lockable on both sides. Flasher type direction indicators operated by self-cancelling arm on steering column. Exterior rear view mirror. Built-in fresh air ventilation system. Provision for fitting air conditioning system, demisters, and radio.

GENERAL DIMENSIONS: Overall length: 176 ins. Overall width: 67.5 ins. Overall height: 62 ins. Wheelbase: 107 ins. Track (front): 53 ins.; (rear): 52 ins. Turning circle: 36 ft. Kerb weight: 2,758 lbs. Maximum G.V.W.: 4,000 lbs.

Ford Motor Company of Australia Pty. Ltd., whose policy is one of continuous improvement, reserves the right, subject to such regulations as may from time to time apply, to change specifications and prices at any time without notice or incurring liability to purchasers.

FORD MOTOR COMPANY OF AUSTRALIA PTY. LTD.

(Incorporated in Victoria) Registered Office: Geelong, Victoria

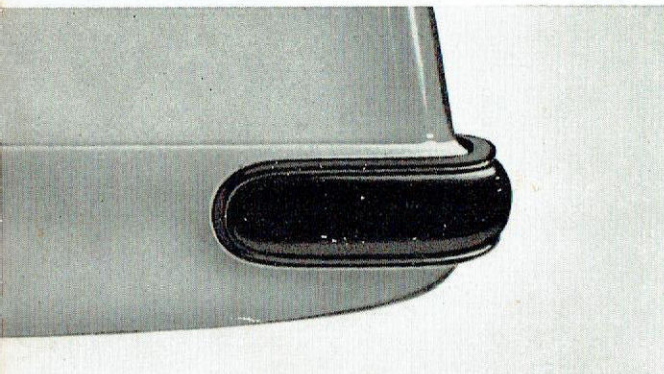

REAR END PROTECTION. Rubber-faced bumperettes curve right around the vital rear corners, absorb shocks better and do not show scratches.

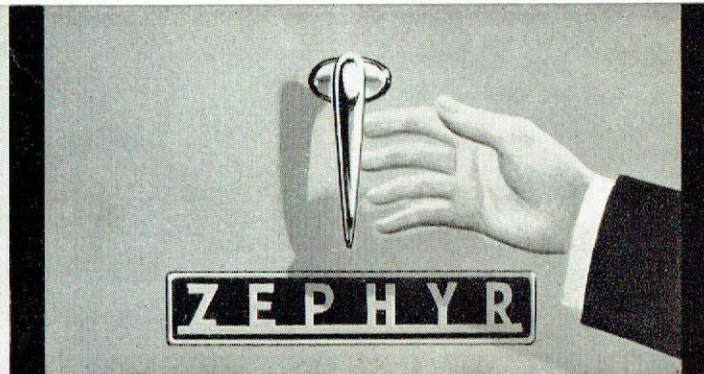

CENTRAL TAILGATE HANDLE allows easy, single-handed operation. The tailgate suspension chains are P.V.C. covered for load-protection.

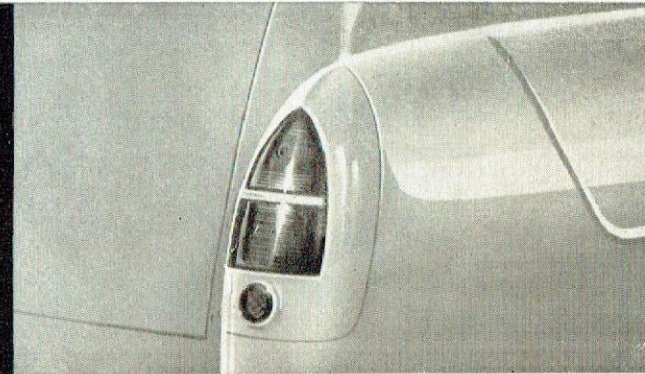

COMPACT TWIN TAIL-LIGHT ASSEMBLY . . . incorporates red stop light, amber flashing turn-indicator lights and built-in reflectors.

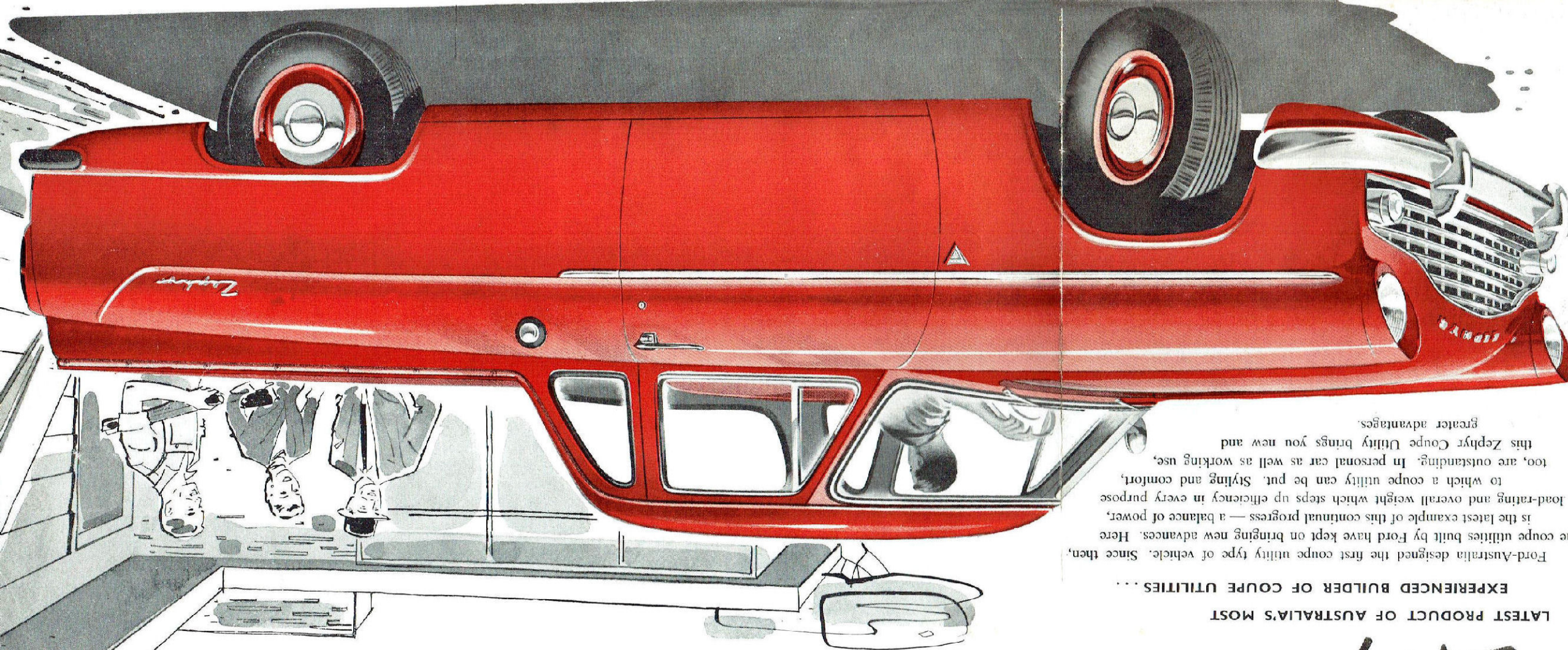

- (1) Zephyr 25.4 h.p. O.H.V. 6 cyl. engine—famous for extra, more flexible performance and 96" length of load area.
- (2) Widespread interior comfort of utility and to take loading stress.
- (3) Heavy duty steel strips on top over-square design.
- (4) Widespread interior comfort of utility space panels for extra strength and to take loading stress.
- (5) Utility space sides are of double panels of husky steel with wide utility space.
- (6) Remarkable suspension system combining greater smoothness with road-hugging stability.
- (7) Wide front track and small turning circle of 36' for extra stability and manoeuvrability.
- (8) Heavy-duty, 6-ply 6.70 x 13 tyres on pressed steel wheels with wide-base rims.
- (9) Separate, locking compartment for spare tyre under fuggage.
- (10) Separate, locking compartment for spare tyre under fuggage.
- (11) Heavy-duty, 6-ply 6.70 x 13 tyres on pressed steel wheels with wide-base rims.

EVERY BASIC FEATURE MEANS A BASIC INCREASE IN COUPE UTILITY USEFULNESS

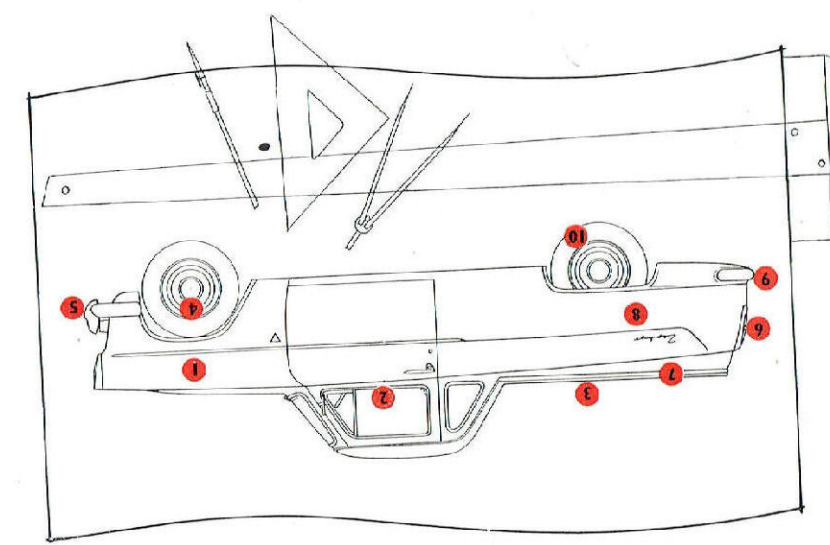

DESIGNED FOR TODAY'S INCREASING AND MORE VERSATILE USE OF COUPE UTILITIES ...

LATEST PRODUCT OF AUSTRALIA'S MOST EXPERIENCED BUILDER OF COUPE UTILITIES ...

Ford-Australia designed the first coupe utility type of vehicle. Since then, the coupe utilities built by Ford have kept on bringing new advances. Here is the latest example of this continual progress—a balance of power, load-rating and overall weight which steps up efficiency in every purpose to which a coupe utility can be put. Styling and comfort, too, are outstanding. In personal car as well as working use, this Zephyr Coupe Utility brings you new and greater advantages.

from power to weight and load ratios to good looks -- Zephyr HAS MORE FOR WORK AND MORE FOR AFTER-WORK LEISURE

Specifications ZEPHYR COUPE-UTILITY

ENGINE: Six cylinder cast integrally with upper half of crankcase; bore 3.25 ins.; stroke 3.13 ins. Capacity 155.8 cu. ins. Overhead valves, push rod operated from harmonic cams in cylinder block. Compression ratio 6.9:1. B.H.P. 80 at 4,200 R.P.M. Torque 128 lbs./ft. at 2,000 R.P.M. Four bearing crankshaft with integral weights, dynamically balanced. Detachable cast-iron cylinder head incorporating volume controlled combustion chambers for economy and smooth running. Special auto-thermic alloy pistons. Three point suspension of engine and gear box giving remarkably smooth power flow.

ENGINE LUBRICATION: Pressure feed by submerged gear pump to crankshaft main bearings, big-end bearings and camshaft bearings via drillings in cylinder block and crankshaft. Full flow type oil filter fitted direct to cylinder block. Accessible dip stick and oil filter. Sump capacity with oil filter 8.5 pints.

IGNITION: 12 volt battery and coil (battery accessibly located under hood)—distributor has automatic advance and retard and additional vacuum control. Sparking plug size 14 mm. Firing order 1, 5, 3, 6, 2, 4.

FUEL SYSTEM: Diaphragm type fuel pump mechanically operated. Down draught carburettor has special choke control and is fitted with combined air cleaner and silencer. Electrical petrol gauge. Petrol tank capacity 11 gallons.

COOLING SYSTEM: Belt-driven fan and water pump with thermostatic heat control. Tube and fin type radiator. Capacity of system 22 pints.

TRANSMISSION: Clutch-dry single plate spring cushioned. Hydraulic operation from pedal to heavy duty, ball-bearing thrust release. Remote control of gears on steering column. Light action synchro-mesh on top and second gears. Helically cut constant mesh gears. Three forward speeds. Overall ratio—3.90 to 1, 6.40 to 1, and 11.06 to 1. Reverse 15.06 to 1. Oil capacity of gearbox 2.5 pints approximately.

REAR AXLE: 34 floating, hypoid final drive. Heavy duty roller and ball bearings. Open type drive shaft. Universal joints have needle roller bearings. Axle ratio—3.90 to 1. Oil capacity 2 1/2 pints approximately.

FRONT SUSPENSION: Independent front wheel suspension employs low periodicity coil springs mounted on special hydraulic double-acting telescopic shock absorbers integral with the wheel spindle assembly. The upper end of this unit rotates in an anti-friction bearing suspended in rubber and mounted on the body high inside wing valance. The base of the wheel assembly is connected via a ball jointed transverser track control arm to a tubular cross-member bolted to underside of the unitary body. An anti-roll torsion bar is fitted which, being triangulated, holds the track control arms in the fore and aft direction. The wide spacing and high location of the springs and shock absorbers, combined with accurately controlled geometry, give excellent riding and steering.

REAR SUSPENSION: Longitudinal semi-elliptic 7-leaf springs rubber insulated. Hydraulic double-acting shock absorbers.

BRAKES: Hydraulic internal—front 9 ins. x 2 1/2 ins. Rear 9 ins. x 1 3/4 ins. Front—two leading shoes, rear—floating expander. Total lining area 147 sq. ins. Foot brake all four wheels, hand brake on rear wheels only.

STEERING: High efficiency worm and peg type. Ratio 16.8 to 1. Steering wheel diameter 17 ins. Two spoke safety type.

WHEELS AND TYRES: Pressed steel with wide base rims. Rust-less steel hub-caps. Tyres 6.70 x 13—6 ply.

ELECTRICAL EQUIPMENT: Two-brush ventilated generator, compensated voltage control. Driver "V" belt easily adjustable. Starter motor. Dual "Windtone" horns operated by horn ring on steering column. Battery: 12 volt 57 amp. hr. at 20 hr. rate.

INSTRUMENTS: Conveniently grouped cluster immediately in front of driver includes speedometer, fuel gauge, ammeter, oil

pressure warning light, direction indicator warning lights, ignition warning light, head-lamp main beam warning light. Instrument lighting controlled by tumbler switch on fascia panel.

CONTROLS: Choke, combined ignition-starter switch, lighting switch, instrument light and windshield wiper. Plastic control knobs. Foot operated head-lamp dimmer switch.

BODY: All-steel welded integral construction. Safety glass all round. Curved type fixed windscreen. Hinged no-draught ventilators embodied in front doors. Safely design push-button door handles. Adjustable, full-width tubular construction bench type seat. Washable vinyl headlining. Spare wheel housed in separate compartment beneath tailgate at rear.

GENERAL EQUIPMENT: Dual windscreen wipers operated from vacuum pump fitted on engine. Moisture-proof, flush fitting hooded headlamps. Separate side lamps. Tail and stop lamps combined. Rear number plate illumination lamps. Interior light. Sun visors. Doors lockable on both sides. Flasher type direction indicators operated by self-cancelling arm on steering column. Exterior rear view mirror. Built-in fresh air ventilation system. Provision for fitting air conditioning system, demisters, and radio.

GENERAL DIMENSIONS: Overall length: 176 ins. Overall width: 67.5 ins. Overall height: 62 ins. Wheelbase: 107 ins. Track (front): 53 ins.; (rear): 52 ins. Turning circle: 36 ft. Kerb weight: 2,758 lbs. Maximum G.V.W.: 4,000 lbs.

Ford Motor Company of Australia Pty. Ltd., whose policy is one of continuous improvement, reserves the right, subject to such regulations as may from time to time apply, to change specifications and prices at any time without notice or incurring liability to purchasers.

FORD MOTOR COMPANY OF AUSTRALIA PTY. LTD.

(Incorporated in Victoria) Registered Office: Geelong, Victoria

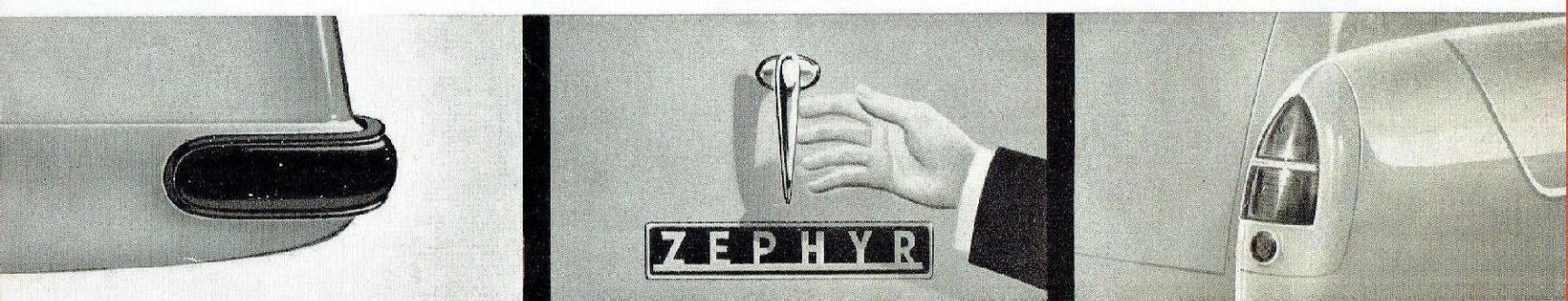

REAR END PROTECTION. Rubber-faced bumperettes curve right around the vital rear corners, absorb shocks better and do not show scratches.

CENTRAL TAILGATE HANDLE allows easy, single-handed operation. The tailgate suspension chains are P.V.C. covered for load-protection.

COMPACT TWIN TAIL-LIGHT ASSEMBLY . . . incorporates red stop light, amber flashing turn-indicator lights and built-in reflectors.

ALL OF ZEPHYR'S FAMOUS PERFORMANCE PLUS LONG, WIDE 8 CWT. UTILITY SPACE —

Zephyr Coupe-Utility

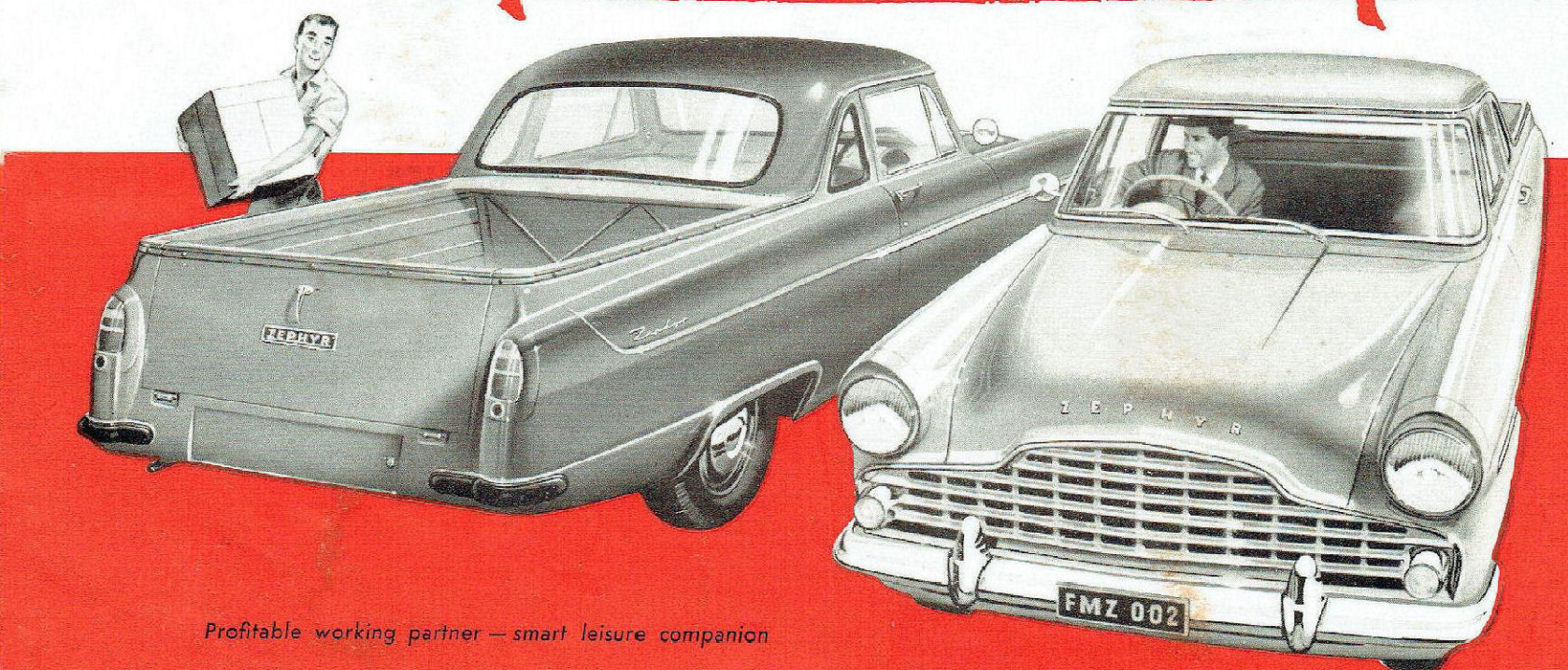

Profitable working partner — smart leisure companion

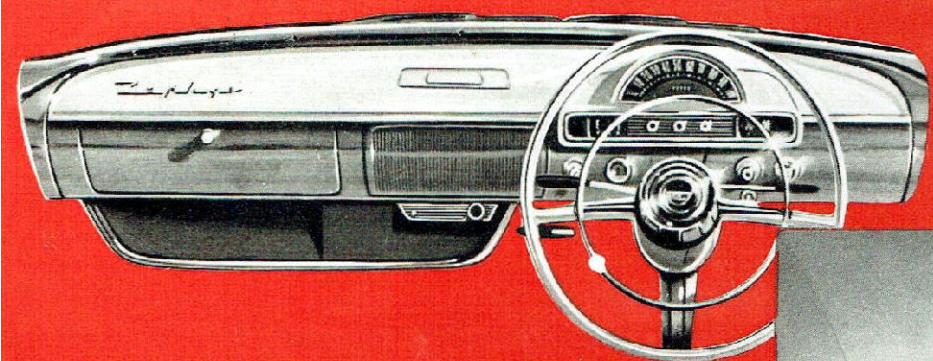

The practical Zephyr facia-panel is covered in soft, non-glare washable Vinyl, all instruments are neatly grouped around the steering column for easier reading, and, as well as a generous-sized glove-box, there are spacious parcel trays underneath the dashboard and at the rear of the seat.

Smart and wide comfort for three!

Slip behind the wheel in Zephyr and you'll know first-hand just how roomy and comfortable it really is. There's no squeeze here for even 3 big people — leg room, hip room and head room are outstanding . . . the deep cushioned seat with special zig-zag spring construction is extra restful, and keeps its shape permanently . . . and the upholstery is of long-wearing washable Vinyl. In vision, too, Zephyr's wrap around windscreen provides an unobstructed view of the road ahead almost from the front wheels onwards. Two interior sun visors guard against sun glare . . . the steering wheel is of dished design to provide added driver-protection in case of impact . . . full-circle horn ring, and chromed door-pulls are provided on both doors . . . in fact the more you look, the more comfort and convenience you'll find.

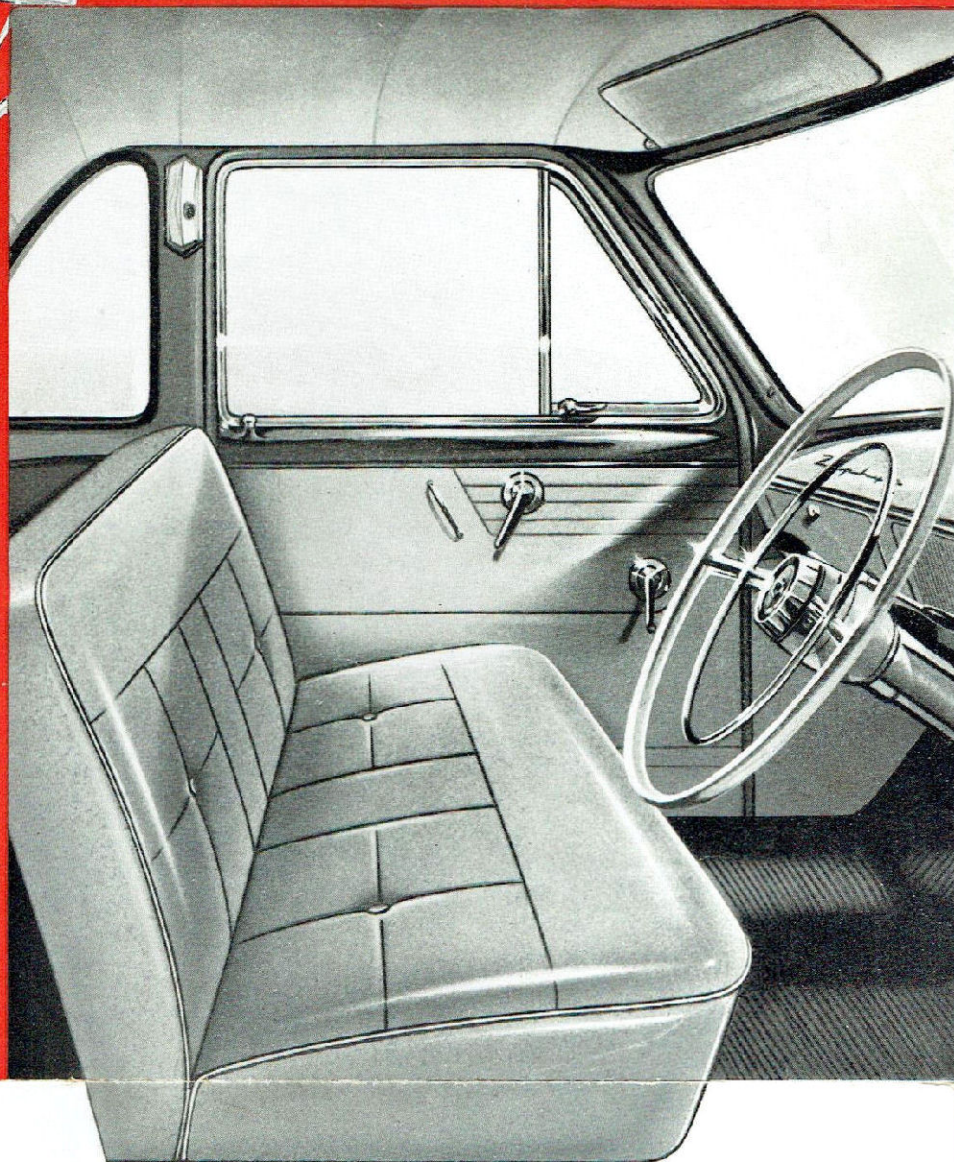

Oversquare O-H-V 6-cylinder power with a plus!

With an R.A.C. rating of 25.4 h.p., this modern engine develops 80 b.h.p. In coupe utility work the flexibility of its performance is particularly important. Faster power output means instant acceleration, big reserves are there for long climbs and heavy going and, in cruising, it does an effortless job at the relatively low rate of revolutions and short piston stroke provided by its oversquare design. This oversquare design is of great importance — for it contributes to greater smoothness, longer life and a fuel economy of up to 30 m.p.g. Power to weight ratio is another big factor in the Zephyr engine's favour. In the normal servicing which a coupe-utility needs in its busy working life, there is an advantage, too, in the easy accessibility of the components in this Zephyr engine.

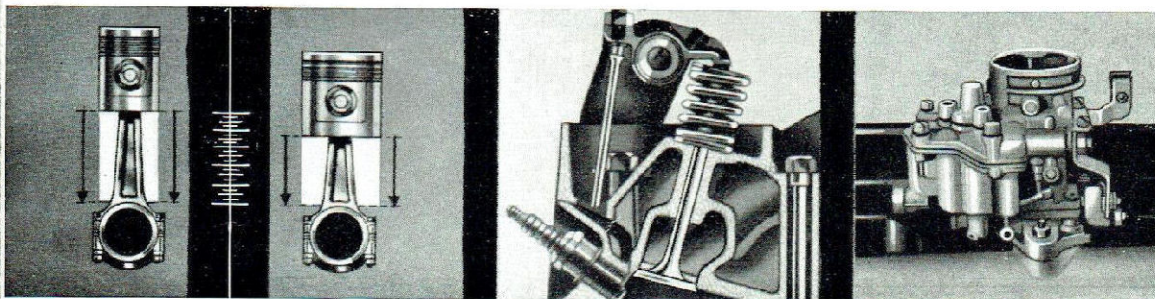
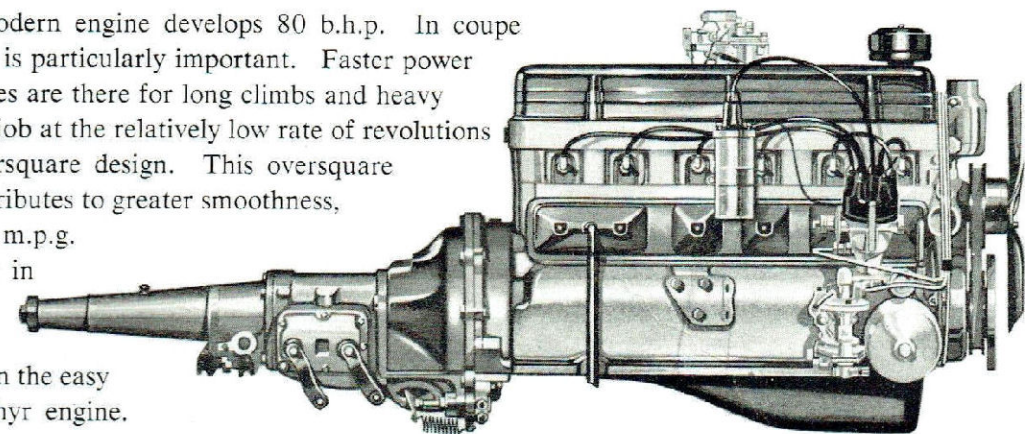

OVERSQUARE, SHORT-STROKE DESIGN: The most efficient power in modern engines comes from oversquare design in which the diameter of the cylinders is increased in relation to their depth. This allows a shorter piston stroke which lessens internal friction, saves wear and gets more efficiency from less petrol. On the right, above, is illustrated Zephyr's "short-stroke" of piston in comparison with that of the conventional engine as shown on the left.

OVERHEAD VALVES: These permit a more efficient combustion head shape which spreads the explosion evenly — and gets more power from every fuel charge. In Zephyr, valve life, too, is greater for the valve guides are an integral part of the cylinder head thus improving heat dissipation.

DOUBLE VENTURI CARBUR-ETTOR: An automatic high-power jet means greater fuel economy through provision of the most efficient fuel-air mixtures for all driving conditions. The down-draught design of the carburettor, special intake manifold design and overhead valves also increase efficiency.

ALL THESE ADVANCES IN ENGINE DESIGN

Four bearing crankshaft with integral weights. The shaft is exceptionally rigid in design and bearing surfaces are larger because of increase in width between centres of cylinder bores . . . improved cooling of exhaust valves . . . full-flow oil filter . . . 3-point rubber-cushioned engine mounting system . . . special design aluminium alloy pistons . . . direct injection of oil on to the cylinder walls when the engine is started cold for longer engine life.

Easy load, easy hold capacity for 8 cwt!

S-P-A-C-E! The keynote of this well-proportioned, all-steel utility is its full 8-cwt. load space. All-steel double panels surround the load area and the top edge of these side panels is formed by heavy duty steel loading strips. The underbody frame has been reinforced centrally so that the vehicle longitudinal channel members extend completely from the front to the rear as a continuous support for the most concentrated load. The hardwood floor is designed for convenient loading height and has steel skid strips.

Removable plates allow immediate access for body service. The tailgate when lowered forms a loading platform level with the floor. And for easy load, easy hold capacity measurement along floor to tailgate is 74", tray width is 57", width of the tailgate is a wide 48", height of side walls is 18.75", and the overall length of load area with the tailgate lowered is 96". A smart weather-proof tonneau cover is standard equipment.

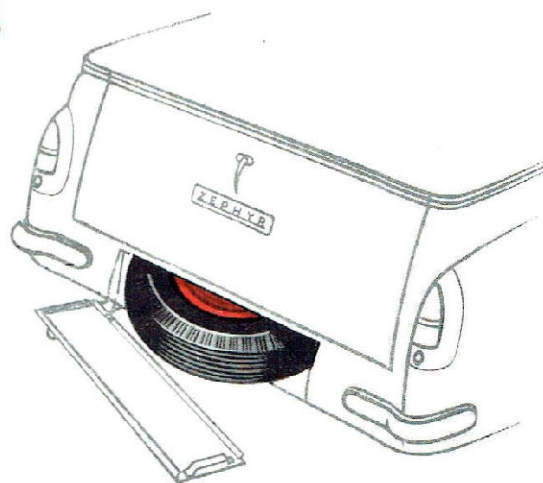

SPARE TYRE COMPARTMENT!

Conveniently placed under the tailgate, and without obstructing the load space area, is a completely separate and weather-tight locking compartment for the spare tyre. The cover-plate is hinged at the left to ensure against loss when spare is taken out.

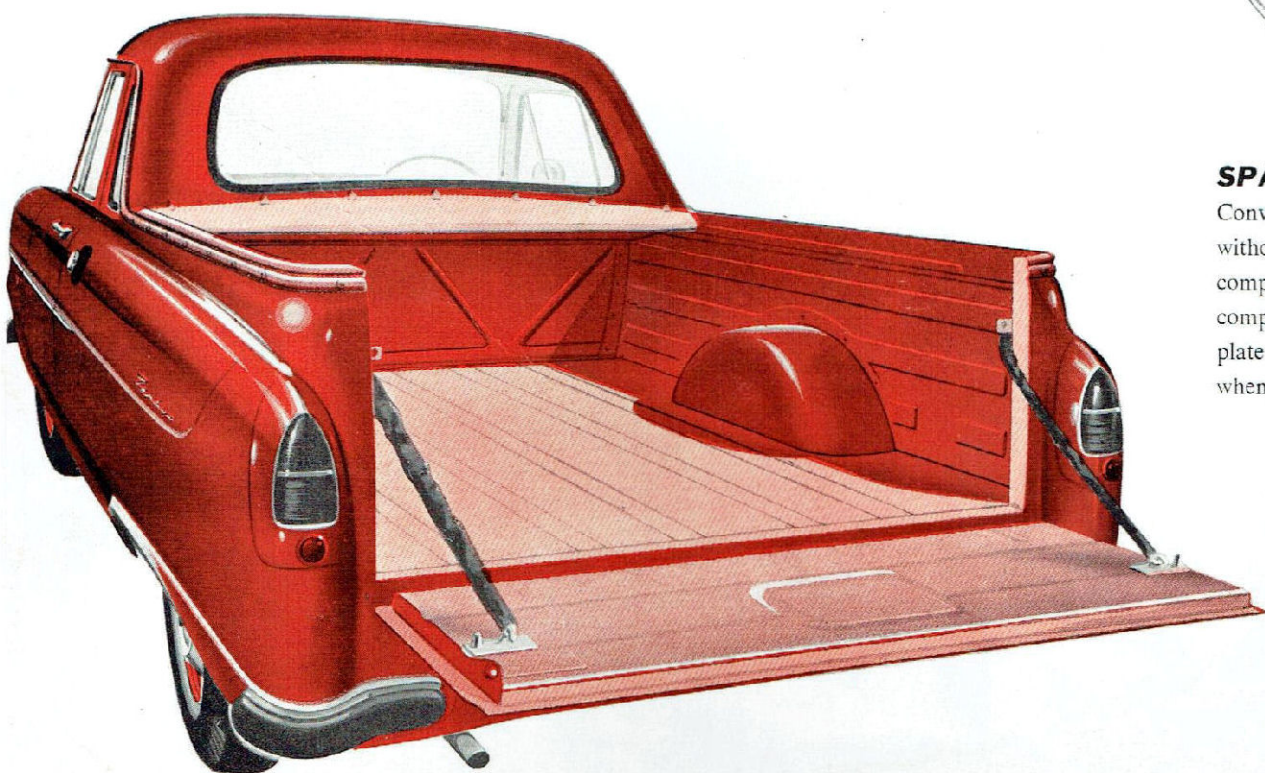

Miracle-Ride smoothness, greater driver control and more stability!

Zephyr's suspension is ideally suited to coupe utility usage. It not only provides a superlatively smooth ride but also extra stability and road-hugging which are particularly noticeable in cornering and on uncertain surfaces. This combination of comfort and safety is achieved through the unique front suspension shown at the left . . . long, heavy duty underslung rear springs . . . lower centre of gravity . . . heavy-duty telescopic shock absorbers . . . wide track . . . and 13" diameter wheels with wide base rims and correspondingly wide road contact of tyres.

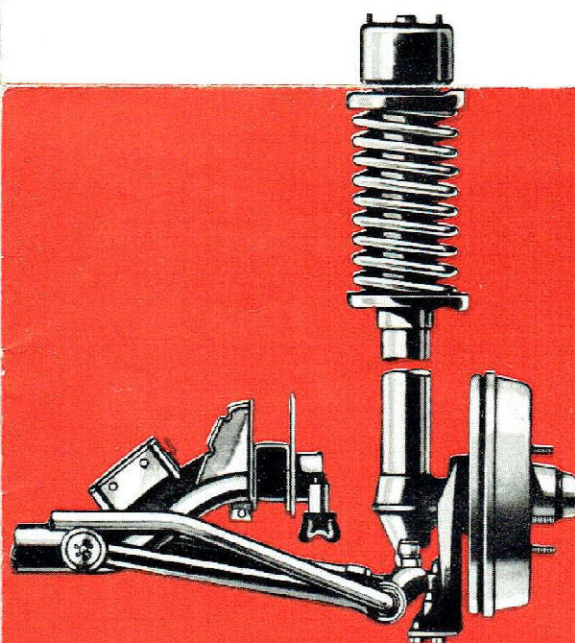

SHORTER TURNING CIRCLE

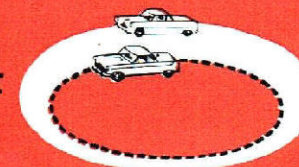

Zephyr is easier to manoeuvre in confined loading areas, in traffic and in any parking situation. The turning circle is only 36' and high-efficiency steering with light but positive action also assists in manoeuvrability. The driver's remarkable vision, front, rear and sides, is another big asset in handling-ease.

EVERY FEATURE INCREASES COUPE UTILITY EFFICIENCY!

Big 9" diameter brakes with a braking area of 147 sq. ins. . . longer wheelbase of 107" . . . pendant-type brake and clutch pedals and clutch action is hydraulically assisted . . . key-turn starting . . . 12-volt electrical system . . . safety "dished" design steering wheel . . . built-in and controllable ventilating system with air-intake coming in the centre

of the engine hood out of the way of road fumes and dust . . . extra strength of box-form integral body frame construction and special central reinforcement of underbody frame so that longitudinal channel members extend completely from front to rear as continuous support for the most concentrated load . . . flasher-type direction indicators . . . wide-opening doors lockable on both sides of vehicle.

Zephyr — the coupe-utility with the finer features!