

# NEW FORD

F250 MAX. GVW 8,000 LBS. / NORMAL CONTROL TRUCKS

240 CID 6 CYL PETROL ENGINE  
WHEELBASE 132 INS.

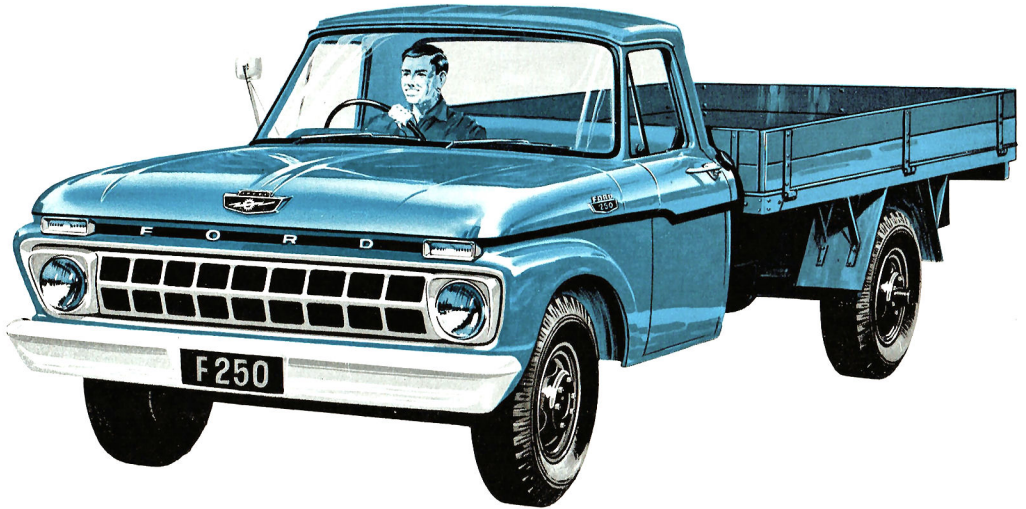

BUILT STRONGER TO LAST LONGER



# NEW FORD F250

BUILT STRONGER TO LAST LONGER!



The new Ford F250 brings new performance and value to trucking in the 8,000 lbs. GVW class. New performance comes from its entirely new 240 CID six cylinder engine and the all-new truck features detailed here. F250's new value comes in offering all this

performance at a price that's right. Before you buy a truck in this class, see how good this new Ford F250 really is. Compare the power, the cab . . . the price. Find out for yourself the advantages of operating a truck that's built stronger to last longer!

## 1. WITH NEW, MORE POWERFUL FORD 240 CID PETROL TRUCK ENGINE

Ford F250's new short stroke truck engine has every advanced design feature; developing a maximum net b.h.p. of 129 at 4,000 r.p.m., and a maximum net torque of 218 lbs. ft. at 2,000 r.p.m. It has these outstanding new features that mean higher performance and greater durability: seven main bearings for added crankshaft strength and long life; chrome-plated top compression rings; crankshaft counterweights for balance against vibration, adding life to crankshaft and engine mounts; hydraulic valve lifters to reduce maintenance and result in quieter running; internal oil lines

to eliminate breakages, ensure good oil retention; a silenced oil bath air cleaner for quiet running; road draft tube crankcase ventilation; wear resistant induction hardened crankshaft; a new, rigid flywheel housing mount; and a new positive displacement type oil pump, that delivers 10% more oil at idling speeds. **In terms of engine performance on your own job, F250 represents absolutely top truck value. So why not take a closer look at this new, more powerful truck engine soon? You'll find that under the engine hood, too, F250 is built stronger to last longer.**

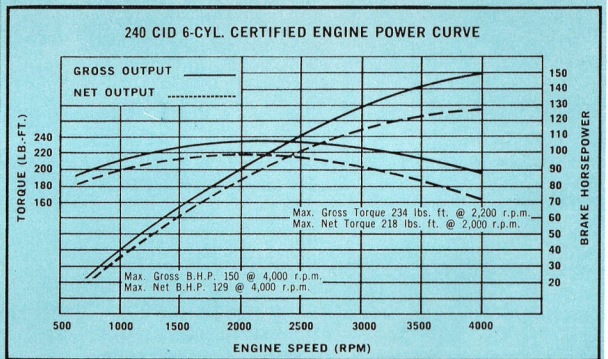
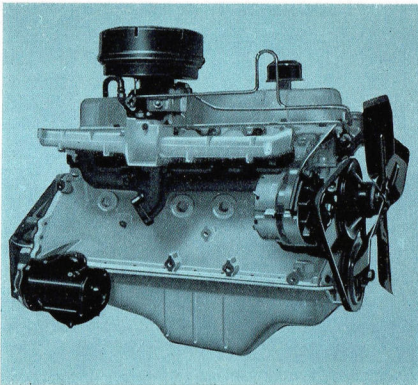

# 10 ways better—the best 8,000 lbs. G.V.W. truck yet!

## 2. "NEW PROCESS 435" 4-SPEED GEARBOX

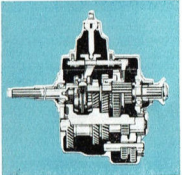

The "New Process 435" 4-speed synchro-silent transmission makes best use of F 250's power. New blocker-type synchronizers, integral with the mainshaft, give greater durability, and smooth, quiet gear engagement with little effort by the driver. It provides more pulling ability and economical operation than 3-speed transmissions.

## 3. NEW, TOUGH LADDER-TYPE FRAME

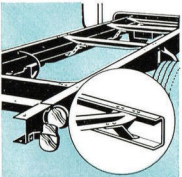

Ladder-type frame with five cross members has alligator-jaw attachment to side rails. Heavy-gauge steel construction gives great frame rigidity. Frames are of S.A.E. standard "X" width to facilitate mounting of standard or custom-built bodies. It gives you a lot of extra strength, durability and payload capacity where it counts.

## 4. NEW 3,800 LBS. FRONT AXLE

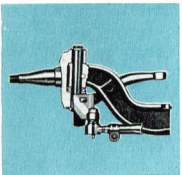

F 250's heat treated high carbon steel front axle has an increased 3,800 lbs. capacity. Its rigid I-Beam construction has increased strength at stress-point, and bronze kingpin bushings reduce friction and wear. There's extra strength in steering arms, knuckles and kingpins. Front axle shown viewed from the rear of the truck looking forward.

## 5. NEW BIG-CAPACITY FRONT SPRINGS

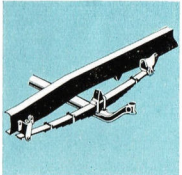

A better ride, empty or loaded, results from new front springs, which are stronger because at the front end the main leaf loop is supported by a half wrap of the second leaf. Double action shock absorbers are rubber insulated to deaden noise. Wide span, plus low deflection rate give most desirable riding qualities and stability.

## 6. NEW FULL-FLOATING REAR AXLE



The rugged full-floating hypoid rear axle has a rated capacity of 7,400 lbs. Heat-hardened alloy steel construction prepares it to take shocks and strains, and more accurate ring gear alignment keeps it working for long periods without adjustment. All gears of alloy steel, heat treated for dependable strength and durability.

## 7. NEW VARIABLE RATE REAR SPRINGS

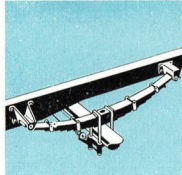

F 250's new variable rate rear springs are long and wide, with the correct resilience to handle the maximum load capacity under the most severe operating conditions. They give a smooth ride, loaded or unloaded. Their low deflection rate also adds to these desirable riding qualities, which greatly relieves operating fatigue.

## 8. NEW BIG RESERVE OF BRAKE POWER

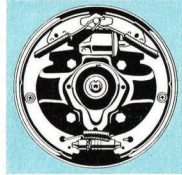

The heavy-duty hydraulic brakes, have had their total lining area increased to 238.04 inches. Internal shoe parking brake gives positive holding on steep inclines, supplements 4-wheel brakes in an emergency. You get the maximum stopping power on the move and the maximum security when standing stationary.

## 9. IMPROVED CAB MOUNTINGS

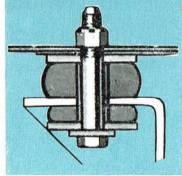

The system of rubber-cushioned 4-point cab mountings on Ford F-series trucks provide a better ride, and insulate the cab against frame stresses and vibration, reducing sheet-metal strains. The cab mountings accordingly improve the operator's comfort, increase cab life and maintain rigidity. They further add to F250's value for money.

## 10. NEW CAB VISIBILITY, COMFORT

The new F 250 cab is wider, closer to the ground, with plenty of room for three big men! Visibility is excellent, with a total of 2,800 square inches of safety glass around you. Every-

thing is there for comfort, safety and convenience. These Ford cabs are specifically designed by truck men to ease long hours at the wheel. Step up and test one for yourself.

1. 1280 sq. inches of safety glass windshield.
2. 4½" seat adjustment.

3. All-weather safety step.
4. Wide doors, with door checks make for easy entry and exit.

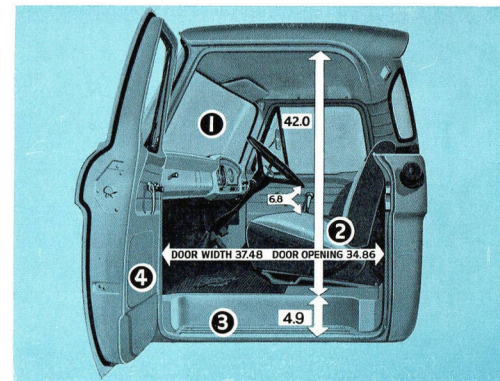

# NEW FORD F250 CHASSIS DIMENSIONS

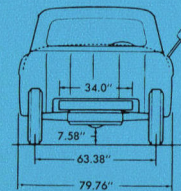
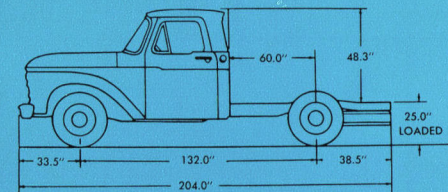

### WEIGHT RATINGS

(Approximate, including fuel, oil and water)

Wheelbase	Front	Rear	Total	Approx. weight available for payload, equipment, etc.
132"	2,415 lbs	1,256 lbs	3,671 lbs	4,329 lbs.



Ford Trucks give you warranty protection for 12,000 miles or 12 months, whichever comes first. Every Ford Truck is warranted against defects in materials and workmanship for this extended period. Owners are responsible only for normal maintenance items. This big extra owner-benefit is provided without any increase in the low prices of Ford trucks.

# NEW FORD F250

ABRIDGED  
SPECIFICATIONS

**ENGINE:** Six cylinder O.H.V. Petrol 4" bore, 3, 18" stroke. Displacement, 240 cu. in. Compression ratio: 8.75 : 1 Horsepower, SAE rating, 38.40. Maximum BHP: Gross, 150 at 4,000 r.p.m. Net, 129 at 4,000 r.p.m. Maximum torque: 234 lbs/ft. at 2,200 r.p.m. Net 218 lbs/ft. at 2,000 r.p.m.

**ENGINE LUBRICATION:** High pressure from high-capacity rotor-type pump with pressure feed to all main and camshaft bearings via drilled passages in engine block and to all connecting rod bearings through drilled leads in crankshaft. Controlled flow to valve train.

**OIL FILTRATION:** Full flow oil filtration through a replaceable cartridge-type filter element. Filter assembly base mounted integral with cylinder block on lower right-hand side of engine completely eliminating external oil lines.

**CRANKCASE VENTILATION:** Road draught tube crankcase ventilation removes corrosive vapours to atmosphere due to the location of tube outlet. This assists in better crankcase breathing.

**OIL CAPACITY:** 5.8 qts.

**FUEL:** Downdraught low silhouette carburettor with externally adjusted fuel setting. Acceleration pump, diaphragm mechanically operated and power valve vacuum operated for maximum power with fuel economy performance. Manually controlled choke with choke and throttle controls interconnected. Oil-bath air cleaner.

**FUEL SUPPLY:** By mechanical pump, driven from engine camshaft. Disposable-type fuel filter integrally mounted on the fuel pump. Protects fuel supply to engine and is readily removable for periodic service or maintenance.

**FUEL TANK CAPACITY:** 15 imperial gallons.

**COOLING SYSTEM:** Pressurised series flow cooling system resulting in direct water flow at high velocity from the front to rear of block then through connecting passages in the cylinder heads over each combustion chamber and back to the outlet at the front for closer temperature control and eliminating hot spots, with the consequent reduction of tendency for engine to detonate. 4-bladed fan, with unequal spacing.

# NEW FORD F250

ABRIDGED SPECIFICATIONS

**ELECTRICAL:** Coil and distributor with vacuum control for automatic advance and retard. 18 mm spark plug. The conical-tapered plugs seat eliminates the need for gaskets and one the plug is properly tightened, no torque loss is encountered providing positive seating under high combustion pressures. Battery located under cab floor.

**BATTERY:** 12 volt 55 amp. 66 plate. Negative terminal grounded.

**CLUTCH:** Single cushion plate dry-disc type. Diameter 11" H.D. Spring-loaded centre for smooth drive. Frictional area 123.7 sq. ins.

**GEARBOX:** "New Process 435" standard equipment. New process cast iron casing. Four forward, one reverse speed standard equipment. Synchromesh on top, third and second. Constant mesh helical gears in all forward speeds.

**GEARBOX RATIOS:** Four-speed—First, 6.685:1; Second, 3.34:1; Third, 1.66:1; Fourth, 1:1; Reverse, 8.26:1.

**POWER TAKE-OFF:** Six-bolt SAE Power take-off on right-hand side of transmission.

**GEARBOX CAPACITY:** 5.4 Imperial pints.

**DRIVE LINE:** Two open propeller shafts are aligned to transmit power with smallest variation between loaded and unloaded positions, this minimising power loss due to deflection of drive line. Adjusted easily by sliding coupling at front end of rear shaft.

**REAR AXLE:** Full floating hypoid type. Single speed. Dana No. 70. ratio 5.13:1. Rated capacity, 7,400 lbs.

**FRONT AXLE:** Front axle features high strength, heat-treated forged alloy-steel I Beam. Rated capacity 3,800 lbs.

**FRAME:** Deep channel section side members, parallel ladder-type frame construction. Cross members flanged "U" type with alligator jaw and channel sections. The parallel-type frame allows installation of both engine and steering gear mechanism with the protection of side rails.

**SPRINGS:** Semi-elliptic springs front and rear. Front springs are wide span, with low deflection rate for desirable riding qualities and stability. The rear springs are long and wide for proper resilience and to carry the recommended load capacity under the most severe conditions.

**STEERING BOX:** Worm and roller-type steering gear design provides quick response to wheel, steady handling ease and rugged construction. Both worm and sector shaft are adjustable to provide long dependable service. The sector shaft in steering mechanism has a long bearing surface and bronze bushings. Steering gear ratio 24.2:1. Wheel dia. 18".

**STEERING BALL SOCKETS:** Tie-rod ends are spring loaded, ball-socket type for automatic take-up of normal ball-socket wear.

**TURNING CIRCLE DIAMETERS:** 132" W/B—44.83' to outer tyre.

**BRAKES:** Full hydraulic system. Total area drum lining front and rear combined, 238.04 sq. ins.

**HAND BRAKES:** Internal shoe parking brake. Parking brake drum is mounted on the rear of the drive line at the rear of transmission. The brake drum is bolted to the flange of the front universal joint and the internal expanding shoe is self-energising. Area: 42.28 sq. ins.

**FRONT BRAKES:** Single-anchor self-energising type.

**REAR BRAKES:** Single servo anchor Bendix 13 x 2.5.

**WHEELS AND TYRES:** Wheels are of the 2-piece pressed steel disc-type with split spring-steel locking rings. Rim sizes: 5.5 x 20—5 wheels. Standard type equipment: 7.50 x 17—8 ply. Wheel base 132".

**CAB:** All-steel welded structure of 3-man design. Boxed section construction in windshield header and filler posts for maximum safety and durability.

**CAB MOUNTING:** The heavy truck 4-point cab-mount system has a far-reaching effect toward virtually eliminating vibration, noise and torsional twist between cab and frame for greater driver comfort and extended sheet metal life.

**INSTRUMENT PANEL:** With easy-to-read full vision instrument cluster containing fuel gauge, oil pressure, high beam and alternator indicator lights, speedometer, mileage recorder and temperature gauge.

**DOORS:** All steel construction mounted on concealed goose-necked hinges. Door checks built into hinges hold doors in open position. Push button handles with rugged rotor-type safety latches. Continuous weather stripping around doors with weather sealed Air Wing Vents.

**WINDOWS:** Full-width windshield, with rear window over 4' wide, large door windows, giving all-round visibility.

**SEATING:** Full-width seat with formed wire springs. Improved basic constructions gives added support for back and knees. 4½" fingertip seat adjustment. Cushion and back-rest covered with durable vinyl.

**VENTILATION:** Hi-dri all-weather ventilation, round grille-type defroster vents that direct air to eye level on windshield for quick, safe visibility.

**CHASSIS EQUIPMENT:** Includes as standard in addition to items mentioned above: Hood, cowl, and dash assembly; front fenders; Hi-dri cowl ventilators; steel toe board; ash receptacle; glove box; horn; electric windshield wipers; treadle-type accelerator pedal; long arm outside rear view mirror on chassis cab; internal sun visor; standard tools in bag, jack; spare wheel.

*Ford Sales Company of Australia Limited, whose policy is one of continuous improvement, reserves the right, subject to such regulations as may from time to time apply, to change specifications and prices at any time without notice or incurring liability to purchasers.*

FORD SALES COMPANY OF AUSTRALIA LIMITED — Registered Office: 1735 Sydney Road, Campbellfield, Victoria.

# NEW FORD F250

ABRIDGED  
SPECIFICATIONS

**ENGINE:** Six cylinder O.H.V. Petrol 4" bore, 3, 18" stroke. Displacement, 240 cu. in. Compression ratio: 8.75 : 1 Horsepower, SAE rating, 38.40. Maximum BHP: Gross, 150 at 4,000 r.p.m. Net, 129 at 4,000 r.p.m. Maximum torque: 234 lbs/ft. at 2,200 r.p.m. Net 218 lbs/ft. at 2,000 r.p.m.

**ENGINE LUBRICATION:** High pressure from high-capacity rotor-type pump with pressure feed to all main and camshaft bearings via drilled passages in engine block and to all connecting rod bearings through drilled leads in crankshaft. Controlled flow to valve train.

**OIL FILTRATION:** Full flow oil filtration through a replaceable cartridge-type filter element. Filter assembly base mounted integral with cylinder block on lower right-hand side of engine completely eliminating external oil lines.

**CRANKCASE VENTILATION:** Road draught tube crankcase ventilation removes corrosive vapours to atmosphere due to the location of tube outlet. This assists in better crankcase breathing.

**OIL CAPACITY:** 5.8 qts.

**FUEL:** Down draught low silhouette carburettor with externally adjusted fuel setting. Acceleration pump, diaphragm mechanically operated and power valve vacuum operated for maximum power with fuel economy performance. Manually controlled choke with choke and throttle controls interconnected. Oil-bath air cleaner.

**FUEL SUPPLY:** By mechanical pump, driven from engine camshaft. Disposable-type fuel filter integrally mounted on the fuel pump. Protects fuel supply to engine and is readily removable for periodic service or maintenance.

**FUEL TANK CAPACITY:** 15 imperial gallons.

**COOLING SYSTEM:** Pressurised series flow cooling system resulting in direct water flow at high velocity from the front to rear of block then through connecting passages in the cylinder heads over each combustion chamber and back to the outlet at the front for closer temperature control and eliminating hot spots, with the consequent reduction of tendency for engine to detonate. 4-bladed fan, with unequal spacing.

# NEW FORD F250

ABRIDGED SPECIFICATIONS

**ELECTRICAL:** Coil and distributor with vacuum control for automatic advance and retard. 18 mm spark plus. The conical-tapered plugs seat eliminates the need for gaskets and one the plug is properly tightened, no torque loss is encountered providing positive seating under high combustion pressures. Battery located under cab floor.

**BATTERY:** 12 volt 55 amp. 66 plate. Negative terminal grounded.

**CLUTCH:** Single cushion plate dry-disc type. Diameter 11" H.D. Spring-loaded centre for smooth drive. Frictional area 123.7 sq. ins.

**GEARBOX:** "New Process 435" standard equipment. New process cast iron casing. Four forward, one reverse speed standard equipment. Synchromesh on top, third and second. Constant mesh helical gears in all forward speeds.

**GEARBOX RATIOS:** Four-speed—First, 6.685:1; Second, 3.34:1; Third, 1.66:1; Fourth, 1:1; Reverse, 8.26:1.

**POWER TAKE-OFF:** Six-bolt SAE Power take-off on right-hand side of transmission.

**GEARBOX CAPACITY:** 5.4 Imperial pints.

**DRIVE LINE:** Two open propeller shafts are aligned to transmit power with smallest variation between loaded and unloaded positions, this minimising power loss due to deflection of drive line. Adjusted easily by sliding coupling at front end of rear shaft.

**REAR AXLE:** Full floating hypoid type. Single speed. Dana No. 70. ratio 5.13:1. Rated capacity, 7,400 lbs.

**FRONT AXLE:** Front axle features high strength, heat-treated forged alloy-steel I Beam. Rated capacity 3,800 lbs.

**FRAME:** Deep channel section side members, parallel ladder-type frame construction. Cross members flanged "U" type with alligator jaw and channel sections. The parallel type frame allows installation of both engine and steering gear mechanism with the protection of side rails.

**SPRINGS:** Semi-elliptic springs front and rear. Front springs are wide span, with low deflection rate for desirable riding qualities and stability. The rear springs are long and wide for proper resilience and to carry the recommended load capacity under the most severe conditions.

**STEERING BOX:** Worm and roller-type steering gear design provides quick response to wheel, steady handling ease and rugged construction. Both worm and sector shaft are adjustable to provide long dependable service. The sector shaft in steering mechanism has a long bearing surface and bronze bushings. Steering gear ratio 24.2:1. Wheel dia. 18".

**STEERING BALL SOCKETS:** Tie-rod ends are spring loaded, ball-socket type for automatic take-up of normal ball-socket wear.

**TURNING CIRCLE DIAMETERS:** 132" W/B—44.83' to outer tyre.

**BRAKES:** Full hydraulic system. Total area drum lining front and rear combined, 238.04 sq. ins.

FORD SALES COMPANY OF AUSTRALIA LIMITED — Registered Office: 1735 Sydney Road, Campbellfield, Victoria.

**HAND BRAKES:** Internal shoe parking brake. Parking brake drum is mounted on the rear of the drive line at the rear of transmission. The brake drum is bolted to the flange of the front universal joint and the internal expanding shoe is self-energising. Area: 42.28 sq. ins.

**FRONT BRAKES:** Single-anchor self-energising type.

**REAR BRAKES:** Single servo anchor Bendix 13 x 2.5.

**WHEELS AND TYRES:** Wheels are of the 2-piece pressed steel disc-type with split spring-steel locking rings. Rim sizes: 5.5 x 20—5 wheels. Standard type equipment: 7.50 x 17—8 ply. Wheel base 132".

**CAB:** All-steel welded structure of 3-man design. Boxed section construction in windshield header and filler posts for maximum safety and durability.

**CAB MOUNTING:** The heavy truck 4-point cab-mount system has a far-reaching effect toward virtually eliminating vibration, noise and torsional twist between cab and frame for greater driver comfort and extended sheet metal life.

**INSTRUMENT PANEL:** With easy-to-read full vision instrument cluster containing fuel gauge, oil pressure, high beam and alternator indicator lights, speedometer, mileage recorder and temperature gauge.

**DOORS:** All steel construction mounted on concealed goose-necked hinges. Door checks built into hinges hold doors in open position. Push button handles with rugged rotor-type safety latches. Continuous weather stripping around doors with weather sealed Air Wing Vents.

**WINDOWS:** Full-width windshield, with rear window over 4' wide, large door windows, giving all-round visibility.

**SEATING:** Full-width seat with formed wire springs. Improved basic constructions gives added support for back and knees. 4½" fingertip seat adjustment. Cushion and back-rest covered with durable vinyl.

**VENTILATION:** Hi-dri- all-weather ventilation, round grille-type defroster vents that direct air to eye level on windshield for quick, safe visibility.

**CHASSIS EQUIPMENT:** Includes as standard in addition to items mentioned above: Hood, cowl, and dash assembly; front fenders; Hi-dri cowl ventilators; steel toe board; ash receptacle; glove box; horn; electric windshield wipers; treadle-type accelerator pedal; long arm outside rear view mirror on chassis cab; internal sun visor; standard tools in bag, jack; spare wheel.

*Ford Sales Company of Australia Limited, whose policy is one of continuous improvement, reserves the right, subject to such regulations as may from time to time apply, to change specifications and prices at any time without notice or incurring liability to purchasers.*

# NEW FORD

F250 MAX. GVW 8,000 LBS. / NORMAL CONTROL TRUCKS

240 CID 6 CYL PETROL ENGINE  
WHEELBASE 132 INS.

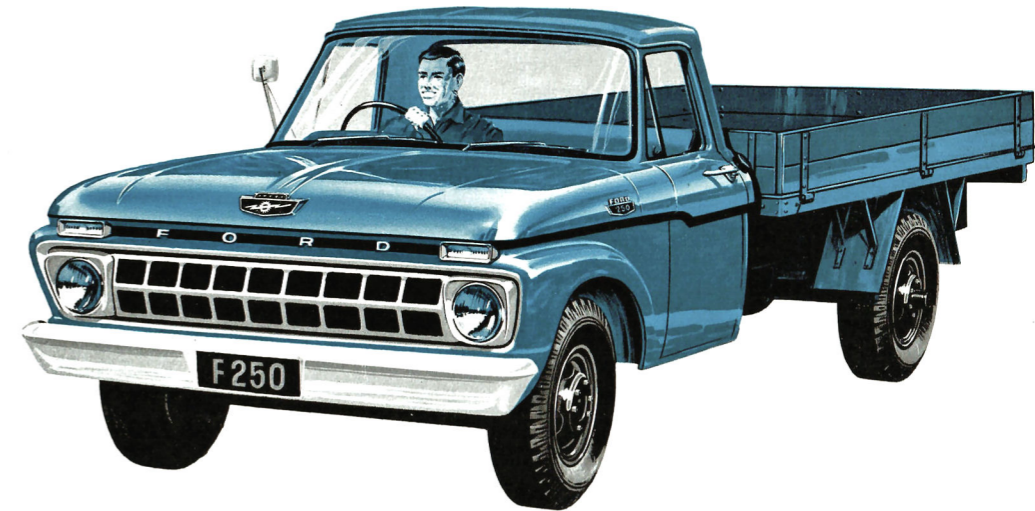

BUILT STRONGER TO LAST LONGER



# NEW FORD F250

BUILT STRONGER TO LAST LONGER!

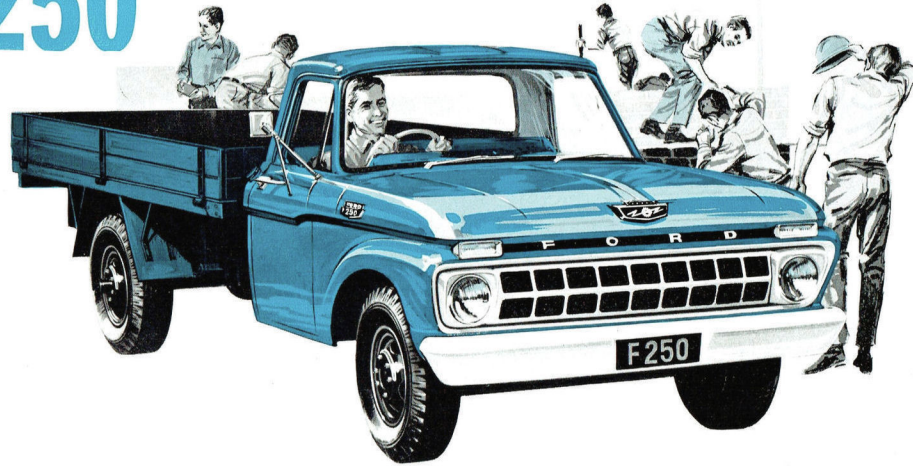

The new Ford F250 brings new performance and value to trucking in the 8,000 lbs. GVW class. New performance comes from its entirely new 240 CID six cylinder engine and the all-new truck features detailed here. F250's new value comes in offering all this

## 1. WITH NEW, MORE POWERFUL FORD 240 CID PETROL TRUCK ENGINE

Ford F250's new short stroke truck engine has every advanced design feature; developing a maximum net b.h.p. of 129 at 4,000 r.p.m., and a maximum net torque of 218 lbs. ft. at 2,000 r.p.m. It has these outstanding new features that mean higher performance and greater durability: seven main bearings for added crankshaft strength and long life; chrome-plated top compression rings; crankshaft counterweights for balance against vibration, adding life to crankshaft and engine mounts; hydraulic valve lifters to reduce maintenance and result in quieter running; internal oil lines

performance at a price that's right. Before you buy a truck in this class, see how good this new Ford F250 really is. Compare the power, the cab . . . the price. Find out for yourself the advantages of operating a truck that's built stronger to last longer!

to eliminate breakages, ensure good oil retention; a silenced oil bath air cleaner for quiet running; road draft tube crankcase ventilation; wear resistant induction hardened crankshaft; a new, rigid flywheel housing mount; and a new positive displacement type oil pump, that delivers 10% more oil at idling speeds. **In terms of engine performance on your own job, F250 represents absolutely top truck value. So why not take a closer look at this new, more powerful truck engine soon? You'll find that under the engine hood, too, F250 is built stronger to last longer.**

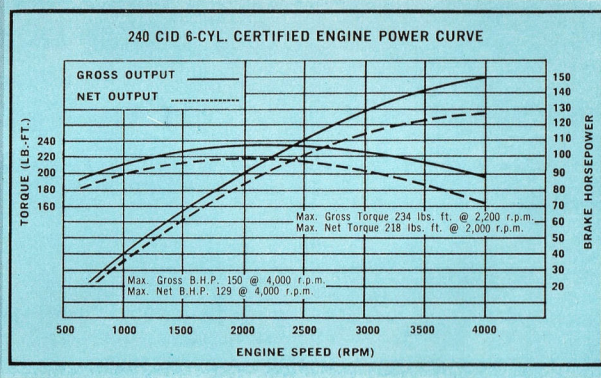
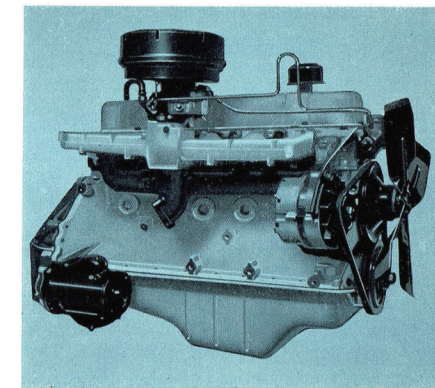

## 10 ways better — the best 8,000 lbs. G.V.W. truck yet!

### 2. "NEW PROCESS 435" 4-SPEED GEARBOX

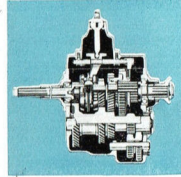

The "New Process 435" 4-speed synchro-silent transmission makes best use of F 250's power. New blocker-type synchronizers, integral with the mainshaft, give greater durability, and smooth, quiet gear engagement with little effort by the driver. It provides more pulling ability and economical operation than 3-speed transmissions.

### 3. NEW, TOUGH LADDER-TYPE FRAME

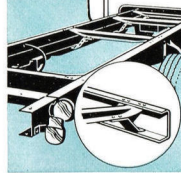

Ladder-type frame with five cross members has alligator-jaw attachment to side rails. Heavy-gauge steel construction gives great frame rigidity. Frames are of S.A.E. standard "X" width to facilitate mounting of standard or custom-built bodies. It gives you a lot of extra strength, durability and payload capacity where it counts.

### 4. NEW 3,800 LBS. FRONT AXLE

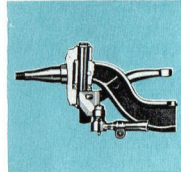

F 250's heat treated high carbon steel front axle has an increased 3,800 lbs. capacity. Its rigid I-Beam construction has increased strength at stress-point, and bronze kingpin bushings reduce friction and wear. There's extra strength in steering arms, knuckles and kingpins. Front axle shown viewed from the rear of the truck looking forward.

### 5. NEW BIG-CAPACITY FRONT SPRINGS

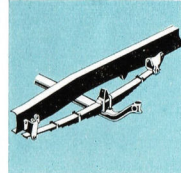

A better ride, empty or loaded, results from new front springs, which are stronger because at the front end the main leaf loop is supported buy a half wrap of the second leaf. Double action shock absorbers are rubber insulated to deaden noise. Wide span, plus low deflection rate give most desirable riding qualities and stability.

### 6. NEW FULL-FLOATING REAR AXLE

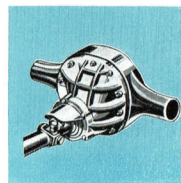

The rugged full-floating hypoid rear axle has a rated capacity of 7,400 lbs. Heat-hardened alloy steel construction prepares it to take shocks and strains, and more accurate ring gear alignment keeps it working for long periods without adjustment. All gears of alloy steel, heat treated for dependable strength and durability.

### 7. NEW VARIABLE RATE REAR SPRINGS

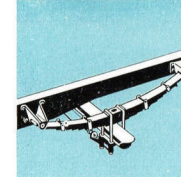

F 250's new variable rate rear springs are long and wide, with the correct resilience to handle the maximum load capacity under the most severe operating conditions. They give a smooth ride, loaded or unloaded. Their low deflection rate also adds to these desirable riding qualities, which greatly relieves operating fatigue.

### 8. NEW BIG RESERVE OF BRAKE POWER



The heavy-duty hydraulic brakes, have had their total lining area increased to 238.04 inches. Internal shoe parking brake gives positive holding on steep inclines, supplements 4-wheel brakes in an emergency. You get the maximum stopping power on the move and the maximum security when standing stationary.

### 9. IMPROVED CAB MOUNTINGS

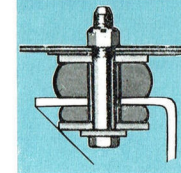

The system of rubber-cushioned 4-point cab mountings on Ford F-series trucks provide a better ride, and insulate the cab against frame stresses and vibration, reducing sheet-metal strains. The cab mountings accordingly improve the operator's comfort, increase cab life and maintain rigidity. They further add to F250's value for money.

### 10. NEW CAB VISIBILITY, COMFORT

The new F 250 cab is wider, closer to the ground, with plenty of room for three big men! Visibility is excellent, with a total of 2,800 square inches of safety glass around you. Every-

thing is there for comfort, safety and convenience. These Ford cabs are specifically designed by truck men to ease long hours at the wheel. Step up and test one for yourself.

1. 1280 sq. inches of safety glass windscreens.
2. 4 1/2" seat adjustment.

3. All-weather safety step.
4. Wide doors, with door checks make for easy entry and exit.

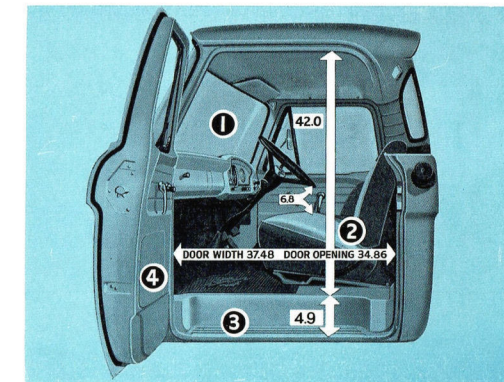

# NEW FORD F250 CHASSIS DIMENSIONS

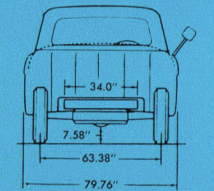
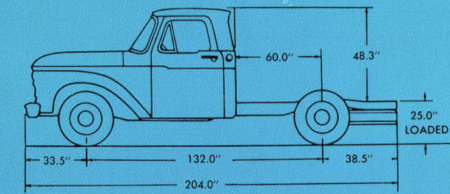

### WEIGHT RATINGS

(Approximate, including fuel, oil and water)

Wheelbase	Front	Rear	Total	Approx. weight available for payload, equipment, etc.
132"	2,415 lbs	1,256 lbs	3,671 lbs	4,329 lbs.

12,000-MILE, 12-MONTH WARRANTY ON ALL FORD TRUCKS

Ford Trucks give you warranty protection for 12,000 miles or 12 months, whichever comes first. Every Ford Truck is warranted against defects in materials and workmanship for this extended period. Owners are responsible only for normal maintenance items. This big extra owner-benefit is provided without any increase in the low prices of Ford trucks.