

# NEW FORD

**F700** MAX. GVW—23,000 LBS. / **NORMAL CONTROL TRUCKS**  
MAX. GCW—38,500 LBS.

300 CID 6 CYL. PETROL ENGINE

WHEELBASES 156", 174", 194".

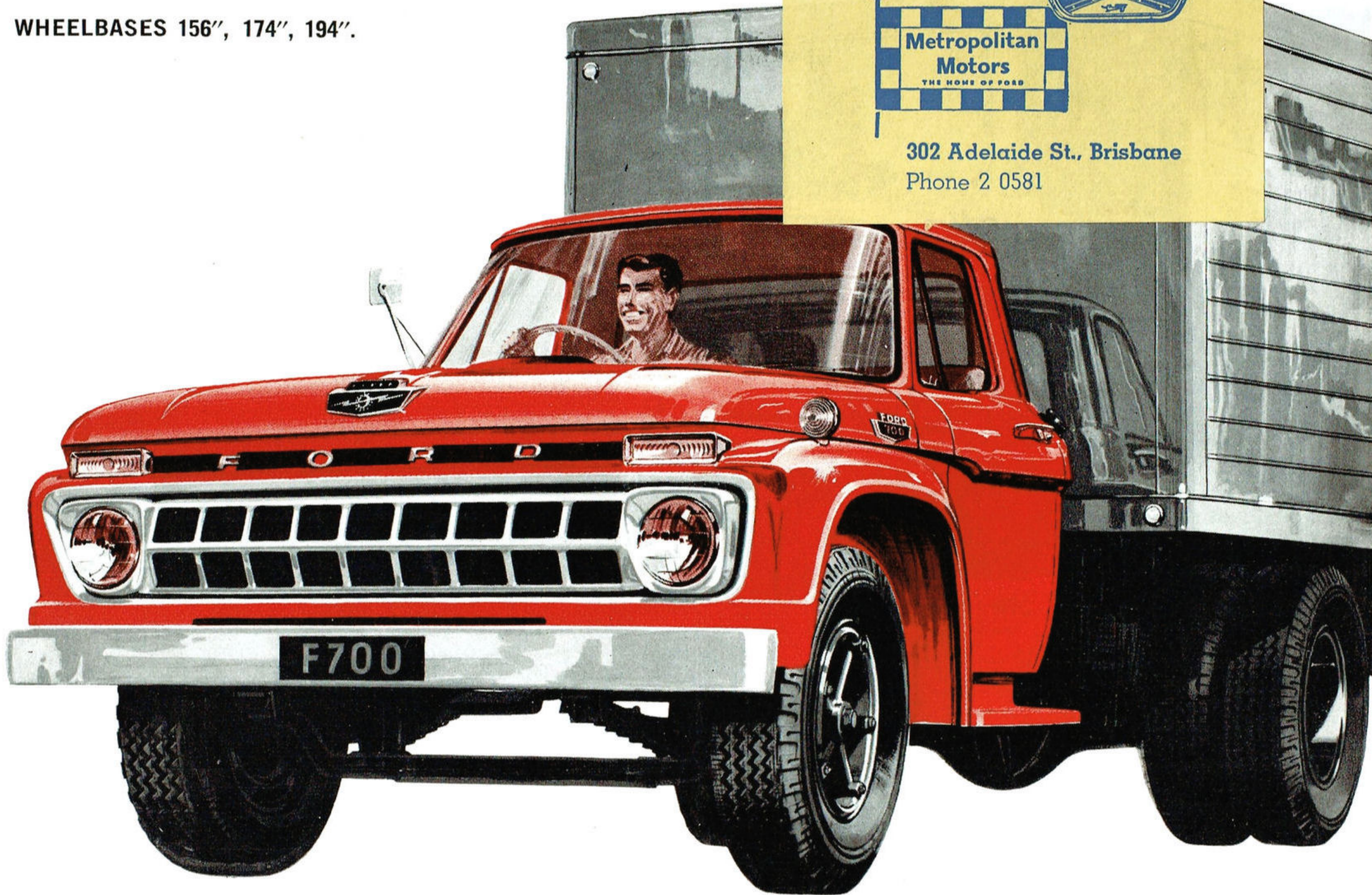

With Compliments from



302 Adelaide St., Brisbane  
Phone 2 0581

**BUILT STRONGER TO LAST LONGER**



# NEW FORD

# F700

**BUILT  
STRONGER  
TO LAST  
LONGER!**



Ford's new F 700 is a truck with more of the extra power and strength you look for in the heavy-duty 23,000 lbs. GVW class. This new Ford truck gets the performance you want from its new 300 CID 6-cylinder petrol truck engine. You'll find it's right for the really tough jobs . . . logging, quarry work or interstate haulage. F 700 will work for you on a wider margin of profit, too. That's

because you buy this new F 700 performance at a price that's right. The new F 700 offers a choice of 3 wheelbases with 5-speed heavy-duty transmission 1 and 2-speed rear axles and it has a great capacity for work. It is built stronger to last longer. And like all the 1965 F-Series, it's the greatest truck value ever.

## 1. WITH NEW, MORE POWERFUL HEAVY DUTY FORD 300 CID PETROL ENGINE

Ford F700's new short stroke heavy-duty 6-cylinder petrol truck engine is of the most modern design. It develops a maximum net b.h.p. of 150 at 3,600 r.p.m. and a maximum net torque of 272 lbs/ft at 1,400-2,100 r.p.m. This new engine is equipped for a long life-time of punishing work. Outstanding features mean higher performance and greater durability: seven main bearings for added crankshaft strength and long life; chrome-plated top compression

rings; crankshaft counterweights for balance against vibration, adding life to crankshaft and engine mounts; hydraulic valve lifters to reduce maintenance and result in quieter running, internal oil lines eliminate breakages, ensure good oil retention; a silenced oil bath air cleaner for quieter running; road draft tube crankcase ventilation; wear resistant induction hardened crankshaft.

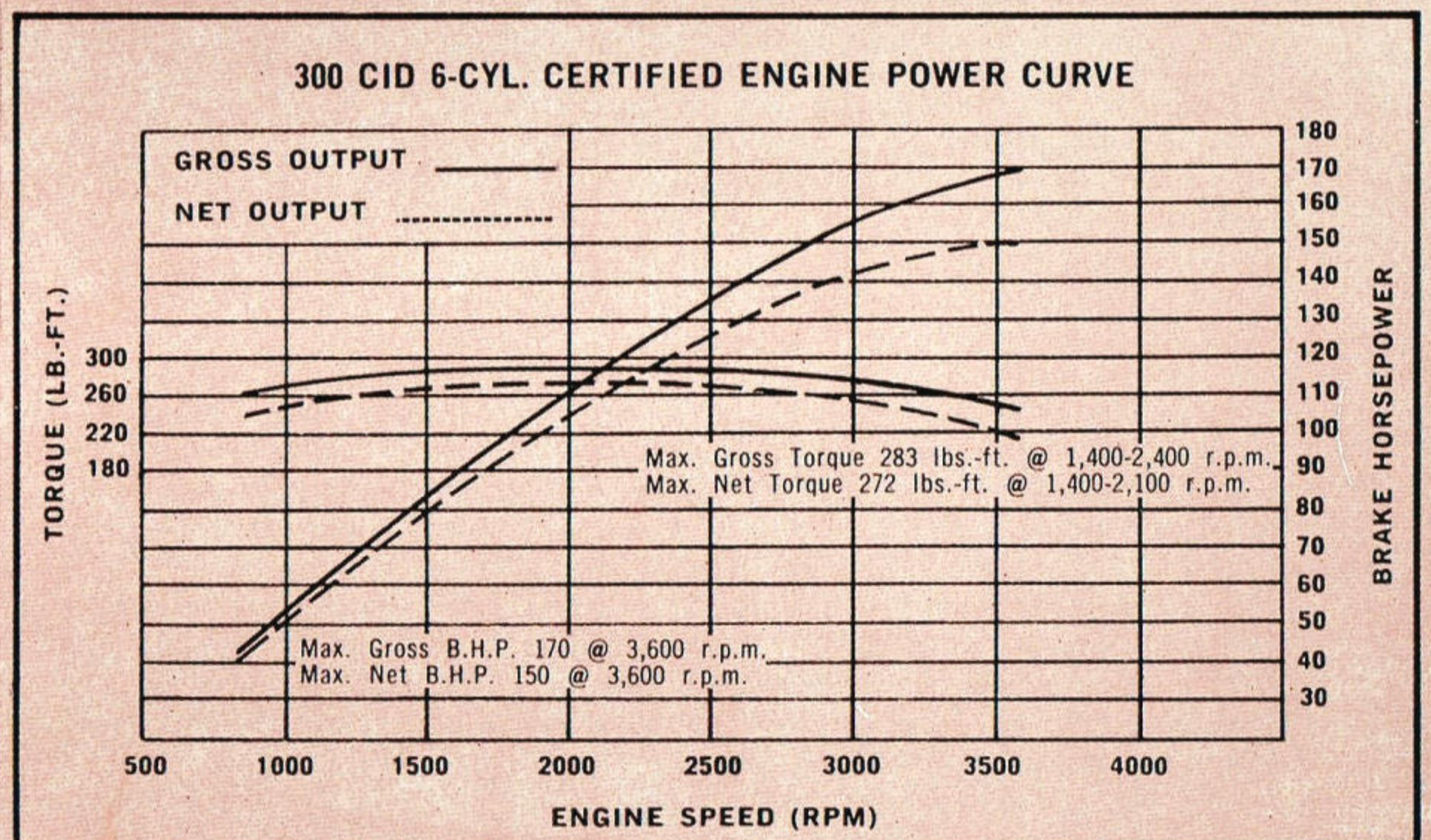
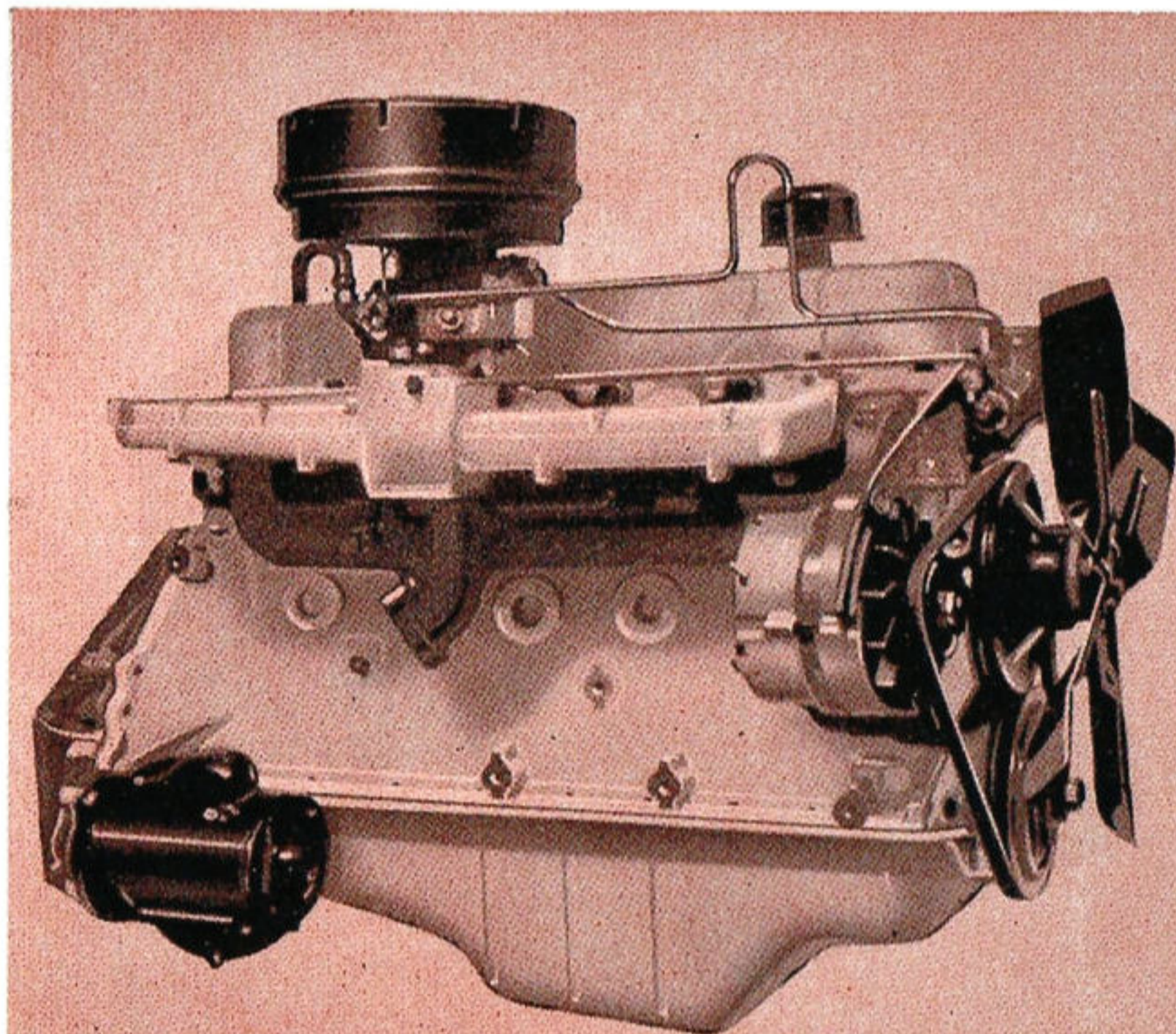

# 9 reasons why F700 is king of the 23,000 lbs. GVW class

## 2. HEAVY-DUTY 5-SP TRANSMISSION

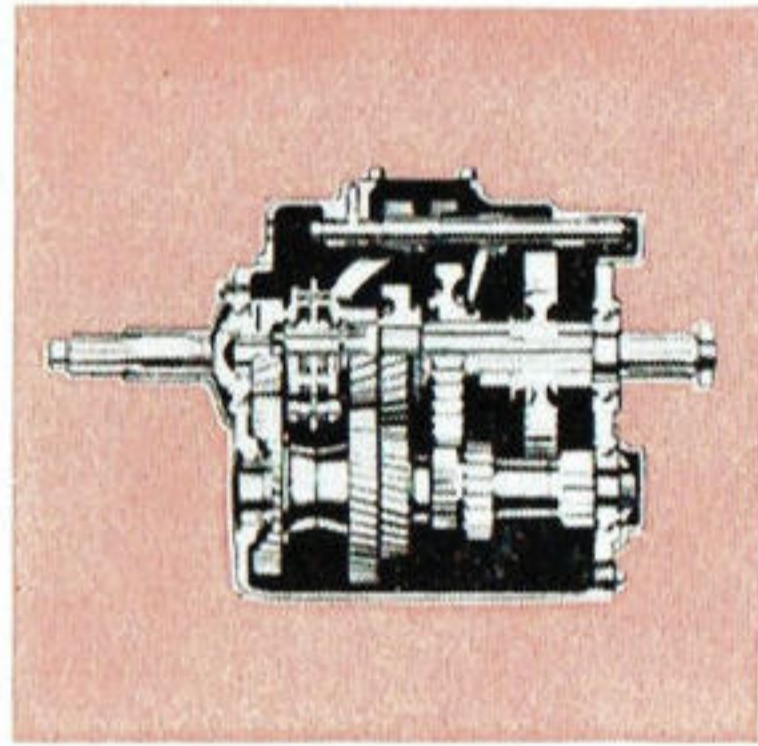

Ford F 700's extra capacity Clark 250V heavy-duty transmission is standard equipment. It has five forward and one reverse speed with synchromesh on fourth and fifth. Constant mesh helical gears are fitted for the top three speeds. The transmission is one of the most proven in the business; with short gear lever travel in low and reverse.

## 3. RUGGED 6,000 LBS. FRONT AXLE

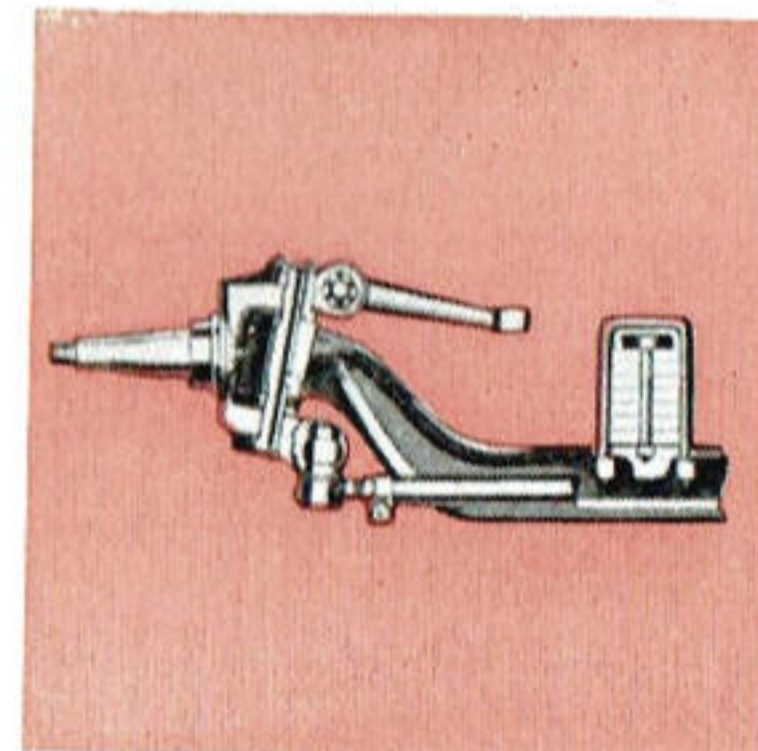

F 700's heat treated high carbon steel front axle has 6,000 lbs. capacity. Its rigid I-Beam construction has extra strength at stress-points, and delrin acetal resin kingpin bushings reduce friction and wear. There's big strength in steering arms, knuckles and kingpins. Illustrated from rear of truck, looking forward.

## 4. BIG CAPACITY RADIUS-LEAF SPRINGS

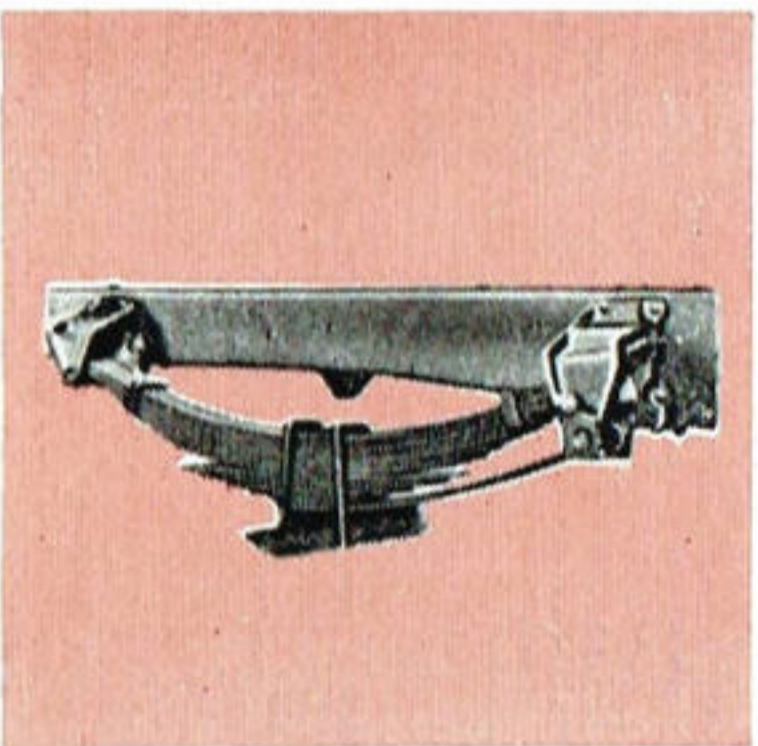

Front springs, of 2,700 lbs. capacity at pad are wide-span semi elliptics with low deflection rate. Rear semi-elliptic springs of 8,100 lbs. capacity use radius leaves to take driving thrust. This allows the main springs to perform their correct function, with desirable riding qualities and stability. They are built stronger, too.

## 5. HEAVY-DUTY 17,000 LBS. REAR AXLE

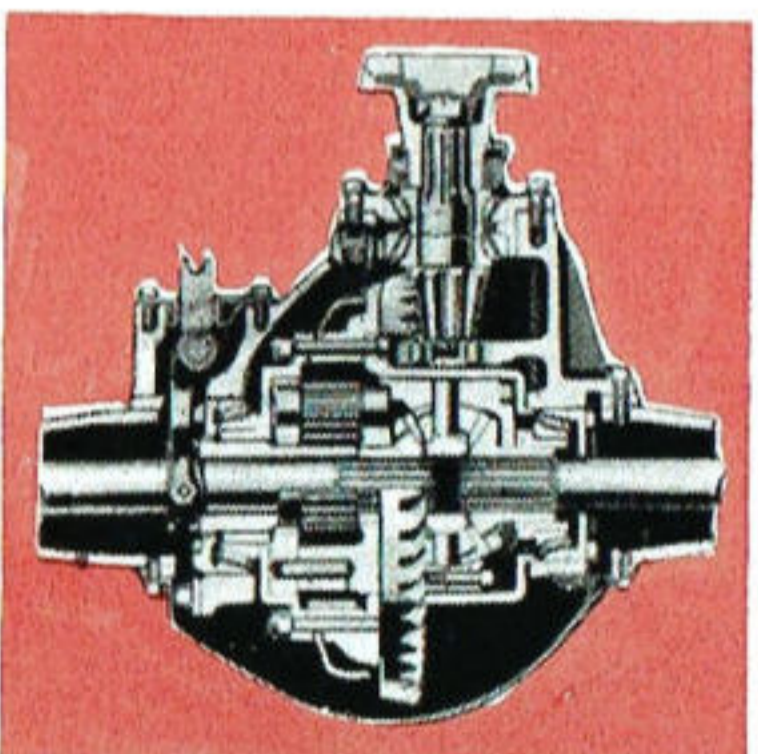

An extra-capacity 17,000 lbs. Eaton spiral bevel full-floating 2-speed rear axle allows a combination of 10 forward and 2 reverse speeds. The 6.50:1 ratio, in high, is ideal for high speeds and light loads, while the 9.04: reduction is for maximum pull for heavy-load work, on steep grades. Here is real rear axle toughness.

## 6. RESERVE BRAKE POWER WITH BIG BOOST

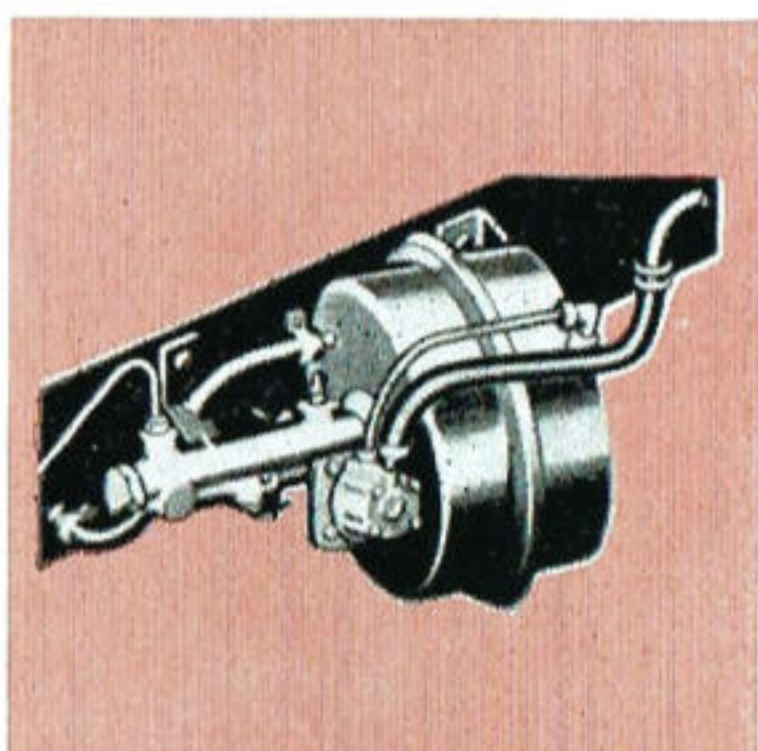

Heavy duty hydraulic brakes have a total drum lining area of 459.46 sq. inches. A big 12 3/4 in. diameter vacuum boost gives great assistance to the operator, reducing fatigue, and keeping brake fade to a minimum under full load conditions. Internal shoe parking brake supplements 4-wheel brakes, giving security while stationary.

## 7. TOUGH, HEAVY LADDER-TYPE FRAME

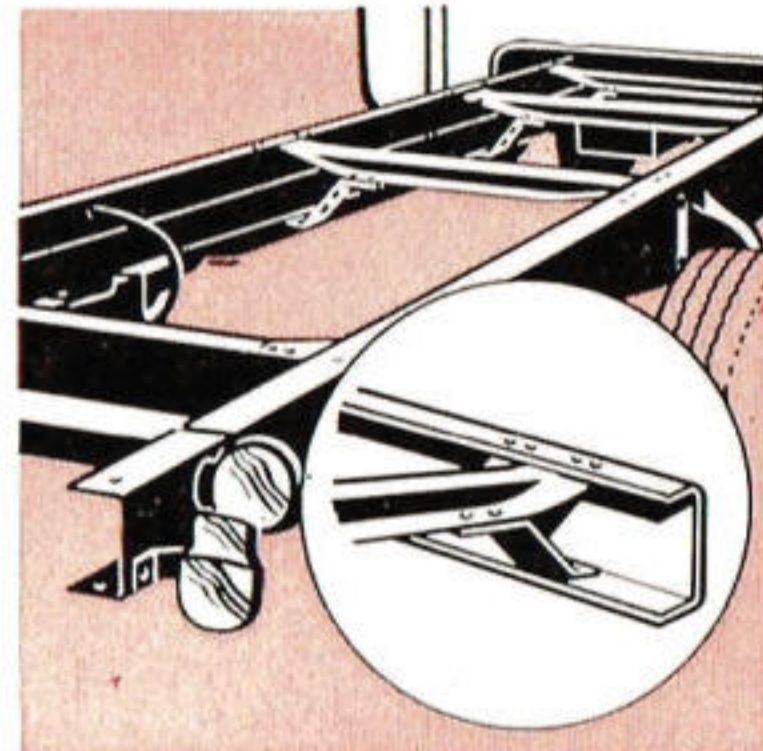

F 700's heavy gauge steel ladder-type frame has cross-members with alligator jaw attachment to side rails. Standard S.A.E. "X" width facilitates fitting of standard or custom-built bodies. The extra strength built into the construction of F700's frame gives great rigidity, durability and payload capacity where it counts most.

Wheelbase	Max. Side Rail Section	Section Modulus	Number of Cross Members
156", 174" 194"	9.31 x 2.97 x 0.28 Inverted L side member reinforcement 9.56 x 3.22 x 0.25	18.0	156", 174" 194" 6 7

## 8. IMPROVED CAB MOUNTINGS

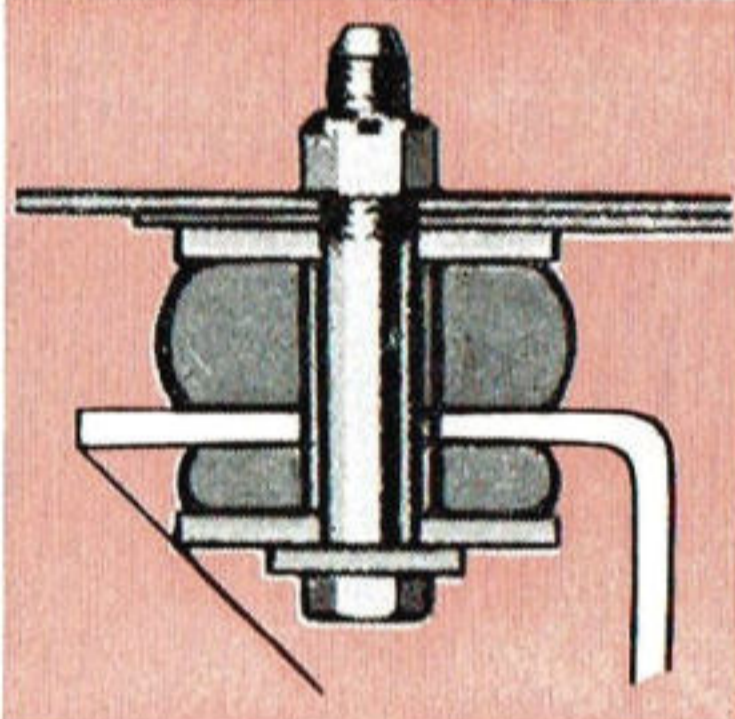

The system of rubber-cushioned 4-point cab mountings on Ford F-series trucks provide a better ride, and insulate the cab against frame stresses and vibration, reducing sheet-metal strains. The cab mountings accordingly improve the operator's comfort and increase cab life. Get into F700's cab and try it for yourself.

## 9. CAB VISIBILITY AND COMFORT

The new F 700 cab is wide, with low step height to the ground. It has plenty of room for three big men, and visibility is excellent, with a total of 2,800 square inches of safety glass around you.

Everything is there for comfort, safety and convenience. Four point rubber cushioned cab mounts reduce cab vibration and stresses on metal-work. It's designed to ease the work.

1. 1280 sq. inches of safety glass windscreen.
2. 4 1/2" seat adjustment.

3. All-weather safety step.
4. Wide doors, with door checks make for easy entry and exit.

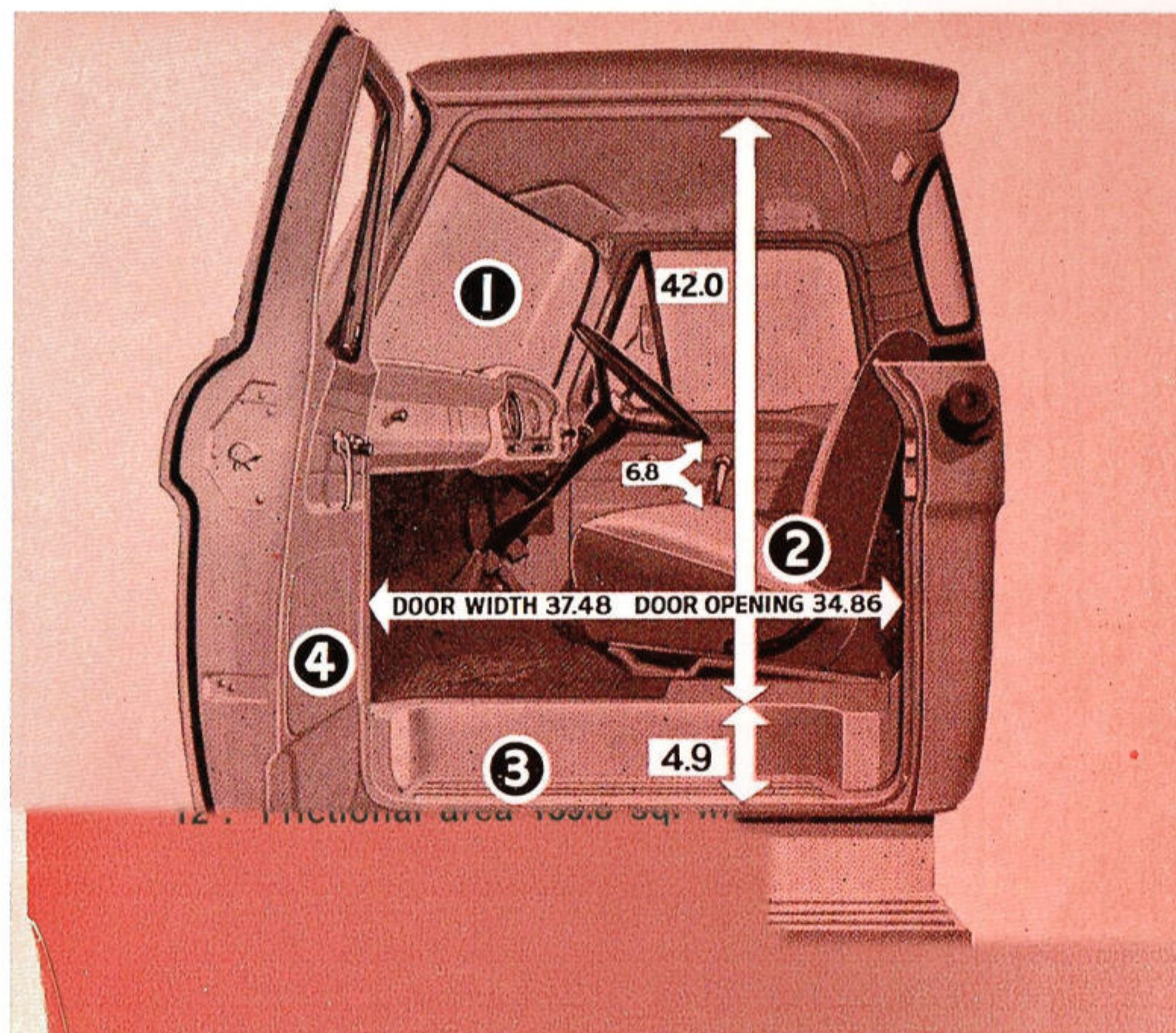

# NEW FORD F700

## CHASSIS DIMENSIONS

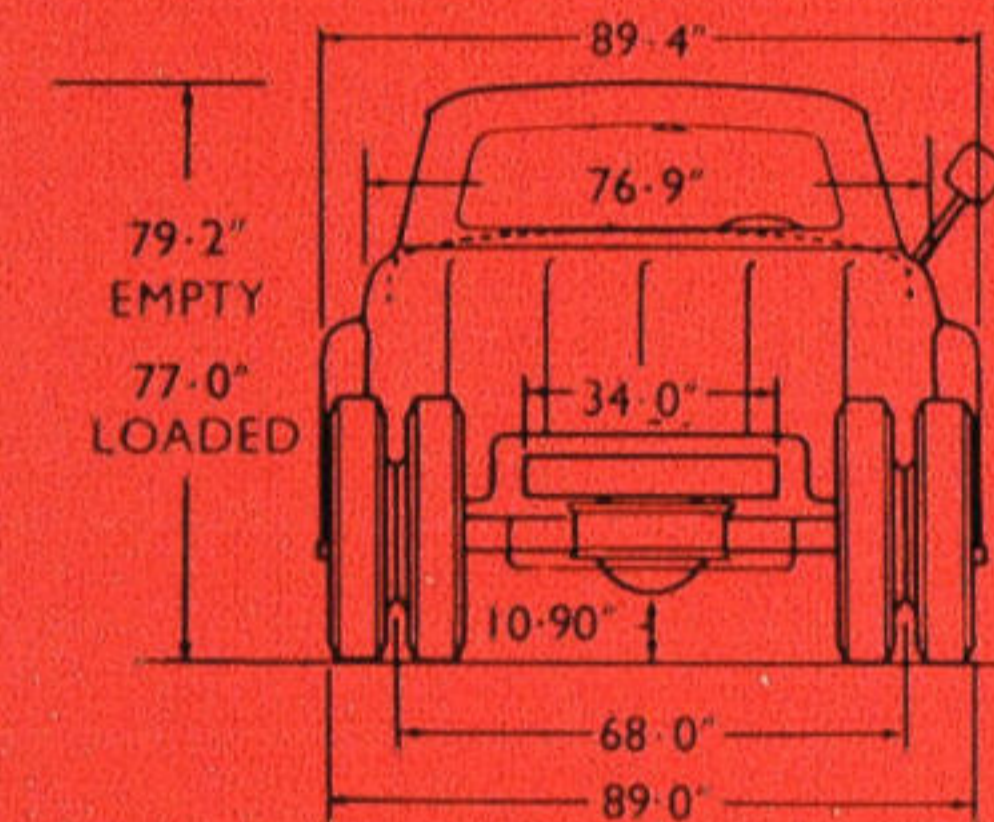
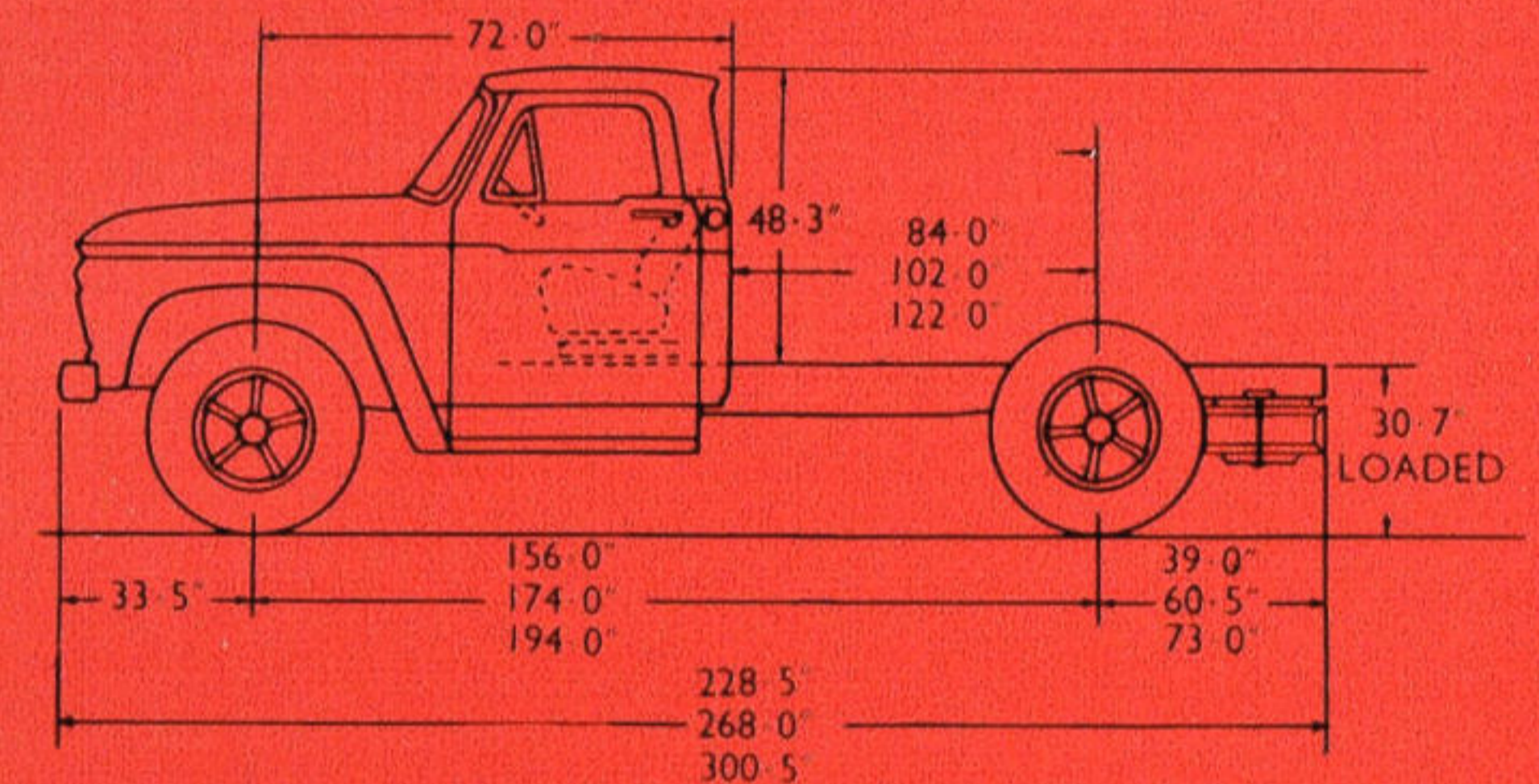

## WEIGHT RATINGS

(GVW's approximate, including fuel, oil and water)

156" W/Base	Front	2,932 lbs
	Rear	2,772 lbs
	Total	5,704 lbs
Approx. weight available for payload and equipment		17,296 lbs
174" W/Base	Front	2,989 lbs
	Rear	2,818 lbs
	Total	5,807 lbs
Approx. weight available for payload and equipment		17,193 lbs
194" W/Base	Front	3,051 lbs
	Rear	2,881 lbs
	Total	5,932 lbs
Approx. weight available for payload and equipment		17,068 lbs

12,000-MILE, 12-MONTH  
(whichever comes first)

# WARRANTY

ON ALL FORD TRUCKS

(excluding normal maintenance parts and services)

Ford Trucks give you warranty protection for 12,000 miles or 12 months, whichever comes first. Every Ford Truck is warranted against defects in materials and workmanship for this extended period. Owners are responsible only for normal maintenance items. This big extra owner-benefit is provided without any increase in the low prices of Ford trucks.

# NEW FORD

## F700 ABRIDGED SPECIFICATIONS

**ENGINE:** STANDARD—Six cylinder O.H.V. 4" bore, 3.98" stroke. Displacement, 300 cu. in. Compression ratio: 8.00:1 Horsepower, RAC rating, 38.40. Maximum BHP: Gross, 170 at 3600 r.p.m. Net, 150 at 3600 r.p.m. Maximum Torque 283 lbs/ft., at 1400-2400 r.p.m. Net, 272 lbs/ft. at 1400-2100 r.p.m.

**ENGINE LUBRICATION:** High pressure from high-capacity rotor-type pump with pressure feed to all main and camshaft bearings via drilled passages in engine block and to all connecting rod bearings through drilled leads in crankshaft. Controlled flow to valve train.

**OIL FILTRATION:** Full flow oil filtration through a replaceable cartridge-type filter element. Filter assembly base mounted integral with cylinder block on lower left-hand side of engine completely eliminating external oil lines.

**CRANKCASE VENTILATION:** Road draught tube crankcase ventilation removes corrosive vapours to atmosphere due to the location of tube outlet. This assists in better crankcase breathing.

**OIL CAPACITY:** 5.8 qts.

**FUEL:** Downdraught low Silhouette Carburettor with externally adjusted fuel setting. Acceleration pump, diaphragm mechanically operated and power valve vacuum operated for maximum power with fuel economy performance. Manually controlled choke with choke and throttle controls interconnected. Oil-bath air cleaner.

**FUEL SUPPLY:** By mechanical pump, driven from engine camshaft. Fuel pump sediment bowl integral with pump.

**COOLING SYSTEM:** Pressurised series flow cooling system resulting in direct water flow from the front to rear of block then through connecting passages in the cylinder heads over each combustion chamber and back to the outlet at the front for closer temperature control and eliminating hot spots, with the consequent reduction of tendency for engine to detonate. 4-bladed fan, with unequal spacing.

**COOLING SYSTEM CAPACITY:** 15.7 Imperial quarts.

**ELECTRICAL:** Coil and distributor with combined centrifugal and vacuum control for automatic advance and retard. 18 mm spark plugs. The conical-tapered plug seat eliminates the need for gaskets and once the plug is properly tightened, no torque loss is encountered, providing positive seating under high combustion pressures. Battery located under cab floor.

**BATTERY:** 12 volt 55 amp. 66 plate. Negative terminal grounded.

**CLUTCH:** Cushion plate, with spring damper. Diameter 12". Frictional area 159.8 sq. ins.

# NEW FORD

## F700 ABRIDGED SPECIFICATIONS

**GEARBOX:** Clark 250v. Five forward, one reverse speed standard equipment. Synchromesh on fourth and fifth. Constant mesh helical gears in top three speeds.

**GEARBOX RATIOS:** First, 7.08:1; Second, 4.09:1; Third, 2.38:1; Fourth, 1.47:1; Fifth, 1:1; Reverse, 7.012:1.

**POWER TAKE-OFF:** Six bolt SAE Power take-off on both sides of transmission.

**GEARBOX CAPACITY:** 7.1 Imperial pints.

**DRIVE LINES:** Two open propeller shafts provide smooth flow of power from the transmission to the rear axle. All units of the drive line are carefully designed and installed in the chassis with the proper inclination to produce straight line drive with minimum angularity between light and loaded positions. Sliding coupling at front-end of rear shaft.

**REAR AXLE:** Full floating spiral bevel type. Eaton 16802, ratios 6.50/9.04. Rated capacity, 17,000 lbs.

**FRONT AXLE:** Front axle features high strength, heat-treated forged alloy-steel. Rated capacity 6000 lbs.

**FRAME:** Deep channel section side members, parallel ladder-type frame construction. Cross members flanged "U" type with alligator jaw and channel sections. The parallel-type frame allows installation of both engine and steering gear mechanism within the protection of side rails.

**SPRINGS:** Front semi-elliptic springs are wide span, with low deflection rate for desirable riding qualities and stability. Rear, semi-elliptic combined with radius leaf enables main springing to perform its correct function without the added strain of taking the driving thrust.

GVW (lbs)	W/BASE	SPRINGS	
		FRONT	REAR
23,000	156" 174" 194"	48" x 2.5", 9-leaf capacity at pad 2700 lbs.	46-59" x 3", 10 main, 2 radius leaves capacity at pad: 8100 lbs. (Auxiliary: 35.5" x 3" 4-leaf, 2250 lbs. cap at pad.-standard equipment)

**STEERING BOX:** Worm and roller-type steering gear design provides quick response to wheel, steady handling ease and rugged construction. Both worm and sector shaft are adjustable to provide long dependable service. The sector shaft has a long bearing surface and bronze bushings. Overall steering gear ratio 27.6:1. Steering wheel diameter—18".

**STEERING BALL SOCKETS:** Tie-rod ends are spring loaded, ball-socket type for automatic take-up of normal ball-socket wear.

**TURNING CIRCLE DIAMETERS:** 156" W/B 52.51'. 174" W/B 57.46'. 194" W/B 62.98. All measurements approximate—taken to centre line of outer tyre.

**BRAKES:** Pedal operated full hydraulic system, vacuum boosted, acting on front and rear wheels. Total area drum lining front and rear combined, 459.46 sq. ins.

**HAND BRAKES:** Internal shoe parking brake. Parking brake drum is mounted on the rear of the drive line at the rear of transmission. The brake drum is bolted to the flange of the front universal joint and the internal expanding shoe is self-energising. Area: 42.28 sq. ins.

**FRONT BRAKES:** Single-anchor self-energising type. Dimensions 14" x 2½".

**REAR BRAKES:** Two cylinder self energising. Dimensions: 15" x 5.0".

**WHEELS AND TYRES:** Wheels are cast spoke. Rim sizes: 20 x 6.5—7 wheels. Standard tyre equipment: Front 8.25 x 20—10 ply; Rear (DUAL) 9.00 x 20—10 ply.

**CAB:** All-steel welded structure of 3-man design. Boxed section construction in windshield header and filler posts for maximum safety and durability.

**CAB MOUNTING:** The heavy truck 4-point cab-mount system has a far-reaching effect toward virtually eliminating vibration, noise and torsional twist between cab and frame for greater driver comfort and extended sheet metal life.

**INSTRUMENT PANEL:** Curved panel with easy-to-read full vision instrument cluster containing fuel gauge, oil pressure and alternator indicator lights, speedometer and temperature gauge.

**DOORS:** All steel construction mounted on concealed goose-necked hinges. Door checks built into hinges hold doors in open position. Push button handles with rugged rotor-type safety latches. Continuous weather stripping around doors with weather sealed Air Wing Vents.

**WINDOWS:** Full-width windshield, with rear window over 4' wide, large door windows, giving all-round visibility.

**SEATING:** Full-width seat with formed wire springs. Improved basic construction gives added support for back and knees. 4½" fingertip seat adjustment. Cushion and back-rest covered with durable vinyl.

**VENTILATION:** Hi-dri all-weather ventilation, round grille-type defroster vents that direct air to eye level on windshield for quick, safe visibility.

**CHASSIS EQUIPMENT:** Included as standard in addition to items mentioned above: Hood, cowl and dash assembly; front fenders; Hi-dri cowl ventilators; steel toe board; instrument panel; speedometer; water temperature gauge; oil pressure and alternator gauges; fuel gauge; ash receptacle; glove box; horn; electric windshield wipers; treadle-type accelerator pedal; long arm outside rear view mirror on chassis cab; internal sun visor; standard tools in bag, jack; spare wheel.

*Ford Sales Company of Australia Limited, whose policy is one of continuous improvement, reserves the right, subject to such regulations as may from time to time apply, to change specifications and prices at any time without notice or incurring liability to purchasers.*

FORD SALES COMPANY OF AUSTRALIA LIMITED—Regd. Office: 1735 Sydney Rd., Campellfield, Vic.

# NEW FORD F700 ABRIDGED SPECIFICATIONS

**ENGINE:** STANDARD—Six cylinder O.H.V. 4" bore, 3.98" stroke. Displacement, 300 cu. in. Compression ratio: 8.00:1 Horsepower, RAC rating, 38.40. Maximum BHP: Gross, 170 at 3600 r.p.m. Net, 150 at 3600 r.p.m. Maximum Torque 283 lbs/ft., at 1400-2400 r.p.m. Net, 272 lbs/ft. at 1400-2100 r.p.m.

**ENGINE LUBRICATION:** High pressure from high-capacity rotor-type pump with pressure feed to all main and camshaft bearings via drilled passages in engine block and to all connecting rod bearings through drilled leads in crankshaft. Controlled flow to valve train.

**OIL FILTRATION:** Full flow oil filtration through a replaceable cartridge-type filter element. Filter assembly base mounted integral with cylinder block on lower left-hand side of engine completely eliminating external oil lines.

**CRANKCASE VENTILATION:** Road draught tube crankcase ventilation removes corrosive vapours to atmosphere due to the location of tube outlet. This assists in better crankcase breathing.

**OIL CAPACITY:** 5.8 qts.

**FUEL:** Downdraught low Silhouette Carburettor with externally adjusted fuel setting. Acceleration pump, diaphragm mechanically operated and power valve vacuum operated for maximum power with fuel economy performance. Manually controlled choke with choke and throttle controls interconnected. Oil-bath air cleaner.

**FUEL SUPPLY:** By mechanical pump, driven from engine camshaft. Fuel pump sediment bowl integral with pump.

**COOLING SYSTEM:** Pressurised series flow cooling system resulting in direct water flow from the front to rear of block then through connecting passages in the cylinder heads over each combustion chamber and back to the outlet at the front for closer temperature control and eliminating hot spots, with the consequent reduction of tendency for engine to detonate. 4-bladed fan, with unequal spacing.

**COOLING SYSTEM CAPACITY:** 15.7 Imperial quarts.

**ELECTRICAL:** Coil and distributor with combined centrifugal and vacuum control for automatic advance and retard. 18 mm spark plugs. The conical-tapered plug seat eliminates the need for gaskets and once the plug is properly tightened, no torque loss is encountered, providing positive seating under high combustion pressures. Battery located under cab floor.

**BATTERY:** 12 volt 55 amp. 66 plate. Negative terminal grounded.

**CLUTCH:** Cushion plate, with spring damper. Diameter 12". Frictional area 159.8 sq. ins.

# NEW FORD F700 ABRIDGED SPECIFICATIONS

**GEARBOX:** Clark 250v. Five forward, one reverse speed standard equipment. Synchromesh on fourth and fifth. Constant mesh helical gears in top three speeds.

**GEARBOX RATIOS:** First, 7.08:1; Second, 4.09:1; Third, 2.38:1; Fourth, 1.47:1; Fifth, 1:1; Reverse, 7.012:1.

**POWER TAKE-OFF:** Six bolt SAE Power take-off on both sides of transmission.

**GEARBOX CAPACITY:** 7.1 Imperial pints.

**DRIVE LINES:** Two open propeller shafts provide smooth flow of power from the transmission to the rear axle. All units of the drive line are carefully designed and installed in the chassis with the proper inclination to produce straight line drive with minimum angularity between light and loaded positions. Sliding coupling at front-end of rear shaft.

**REAR AXLE:** Full floating spiral bevel type. Eaton 16802, ratios 6.50/9.04. Rated capacity, 17,000 lbs.

**FRONT AXLE:** Front axle features high strength, heat-treated forged alloy-steel. Rated capacity 6000 lbs.

**FRAME:** Deep channel section side members, parallel ladder-type frame construction. Cross members flanged "U" type with alligator jaw and channel sections. The parallel-type frame allows installation of both engine and steering gear mechanism within the protection of side rails.

**SPRINGS:** Front semi-elliptic springs are wide span, with low deflection rate for desirable riding qualities and stability. Rear, semi-elliptic combined with radius leaf enables main springing to perform its correct function without the added strain of taking the driving thrust.

GVW (lbs)	W/BASE	SPRINGS	
		FRONT	REAR
23,000	156"	48" x 2.5", 9-leaf capacity at pad 2700 lbs.	46-59" x 3", 10 main, 2 radius leaves capacity at pad: 8100 lbs. (Auxiliary: 35.5" x 3" 4-leaf, 2250 lbs. cap at pad.-standard equipment)
	174"		
	194"		

**STEERING BOX:** Worm and roller-type steering gear design provides quick response to wheel, steady handling ease and rugged construction. Both worm and sector shaft are adjustable to provide long dependable service. The sector shaft has a long bearing surface and bronze bushings. Overall steering gear ratio 27.6:1. Steering wheel diameter—18".

**STEERING BALL SOCKETS:** Tie-rod ends are spring loaded, ball-socket type for automatic take-up of normal ball-socket wear.

**TURNING CIRCLE DIAMETERS:** 156" W/B 52.51'. 174" W/B 57.46'. 194" W/B 62.98. All measurements approximate—taken to centre line of outer tyre.

**BRAKES:** Pedal operated full hydraulic system, vacuum boosted, acting on front and rear wheels. Total area drum lining front and rear combined, 459.46 sq. ins.

**HAND BRAKES:** Internal shoe parking brake. Parking brake drum is mounted on the rear of the drive line at the rear of transmission. The brake drum is bolted to the flange of the front universal joint and the internal expanding shoe is self-energising. Area: 42.28 sq. ins.

**FRONT BRAKES:** Single-anchor self-energising type. Dimensions 14" x 2½".

**REAR BRAKES:** Two cylinder self energising. Dimensions: 15" x 5.0".

**WHEELS AND TYRES:** Wheels are cast spoke. Rim sizes: 20 x 6.5—7 wheels.

Standard tyre equipment: Front 8.25 x 20—10 ply; Rear (DUAL) 9.00 x 20—10 ply.

**CAB:** All-steel welded structure of 3-man design. Boxed section construction in windshield header and filler posts for maximum safety and durability.

**CAB MOUNTING:** The heavy truck 4-point cab-mount system has a far-reaching effect toward virtually eliminating vibration, noise and torsional twist between cab and frame for greater driver comfort and extended sheet metal life.

**INSTRUMENT PANEL:** Curved panel with easy-to-read full vision instrument cluster containing fuel gauge, oil pressure and alternator indicator lights, speedometer and temperature gauge.

**DOORS:** All steel construction mounted on concealed goose-necked hinges. Door checks built into hinges hold doors in open position. Push button handles with rugged rotor-type safety latches. Continuous weather stripping around doors with weather sealed Air Wing Vents.

**WINDOWS:** Full-width windshield, with rear window over 4' wide, large door windows, giving all-round visibility.

**SEATING:** Full-width seat with formed wire springs. Improved basic construction gives added support for back and knees. 4½" fingertip seat adjustment. Cushion and back-rest covered with durable vinyl.

**VENTILATION:** Hi-dri all-weather ventilation, round grille-type defroster vents that direct air to eye level on windshield for quick, safe visibility.

**CHASSIS EQUIPMENT:** Included as standard in addition to items mentioned above: Hood, cowl and dash assembly; front fenders; Hi-dri cowl ventilators; steel toe board; instrument panel; speedometer; water temperature gauge; oil pressure and alternator gauges; fuel gauge; ash receptacle; glove box; horn; electric windshield wipers; treadle-type accelerator pedal; long arm outside rear view mirror on chassis cab; internal sun visor; standard tools in bag, jack; spare wheel.

*Ford Sales Company of Australia Limited, whose policy is one of continuous improvement, reserves the right, subject to such regulations as may from time to time apply, to change specifications and prices at any time without notice or incurring liability to purchasers.*

# NEW FORD

F700 MAX. GVW—23,000 LBS. / MAX. GCW—38,500 LBS. / NORMAL CONTROL TRUCKS

300 CID 6 CYL. PETROL ENGINE

WHEELBASES 156", 174", 194".

With Compliments from

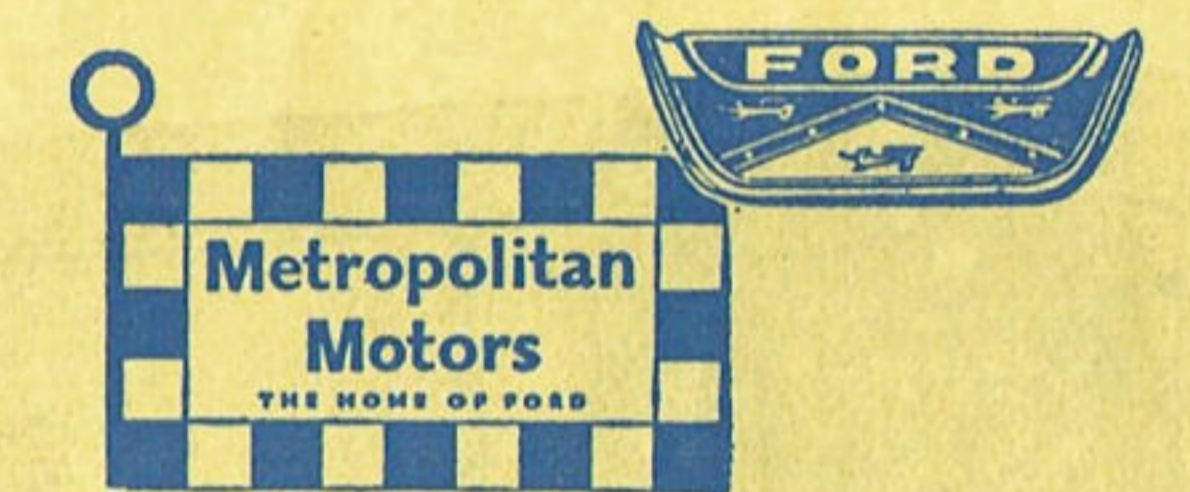

302 Adelaide St., Brisbane  
Phone 2 0581

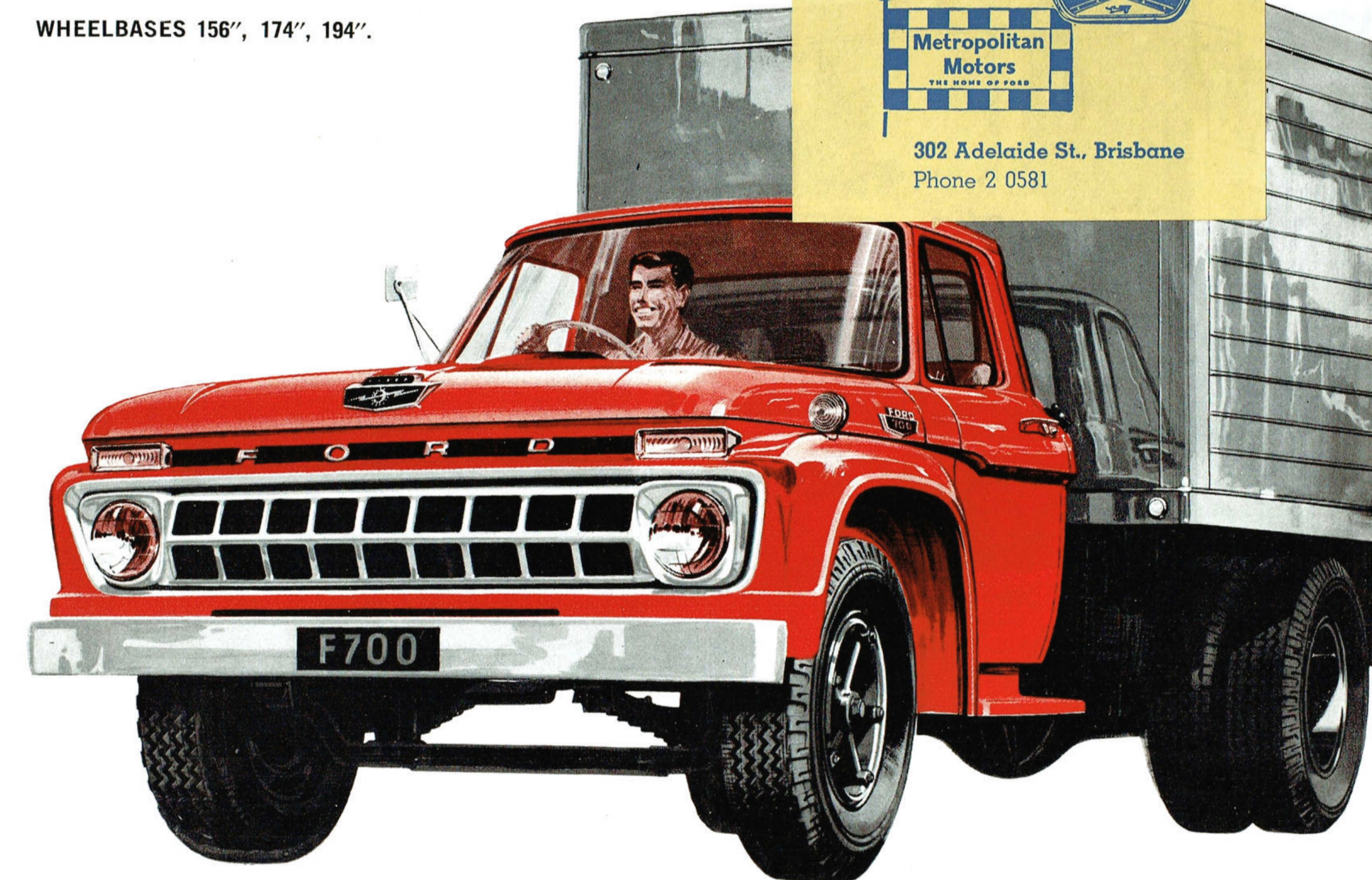

BUILT STRONGER TO LAST LONGER



# NEW FORD F700

**BUILT  
STRONGER  
TO LAST  
LONGER!**



Ford's new F 700 is a truck with more of the extra power and strength you look for in the heavy-duty 23,000 lbs. GVW class. This new Ford truck gets the performance you want from its new 300 CID 6-cylinder petrol truck engine. You'll find it's right for the really tough jobs . . . logging, quarry work or interstate haulage. F 700 will work for you on a wider margin of profit, too. That's

because you buy this new F 700 performance at a price that's right. The new F 700 offers a choice of 3 wheelbases with 5-speed heavy-duty transmission 1 and 2-speed rear axles and it has a great capacity for work. It is built stronger to last longer. And like all the 1965 F-Series, it's the greatest truck value ever.

## 1. WITH NEW, MORE POWERFUL HEAVY DUTY FORD 300 CID PETROL ENGINE

Ford F700's new short stroke heavy-duty 6-cylinder petrol truck engine is of the most modern design. It develops a maximum net b.h.p. of 150 at 3,600 r.p.m. and a maximum net torque of 272 lbs/ft at 1,400-2,100 r.p.m. This new engine is equipped for a long life-time of punishing work. Outstanding features mean higher performance and greater durability: seven main bearings for added crankshaft strength and long life; chrome-plated top compression

rings; crankshaft counterweights for balance against vibration, adding life to crankshaft and engine mounts; hydraulic valve lifters to reduce maintenance and result in quieter running, internal oil lines eliminate breakages, ensure good oil retention; a silenced oil bath air cleaner for quieter running; road draft tube crankcase ventilation; wear resistant induction hardened crankshaft.

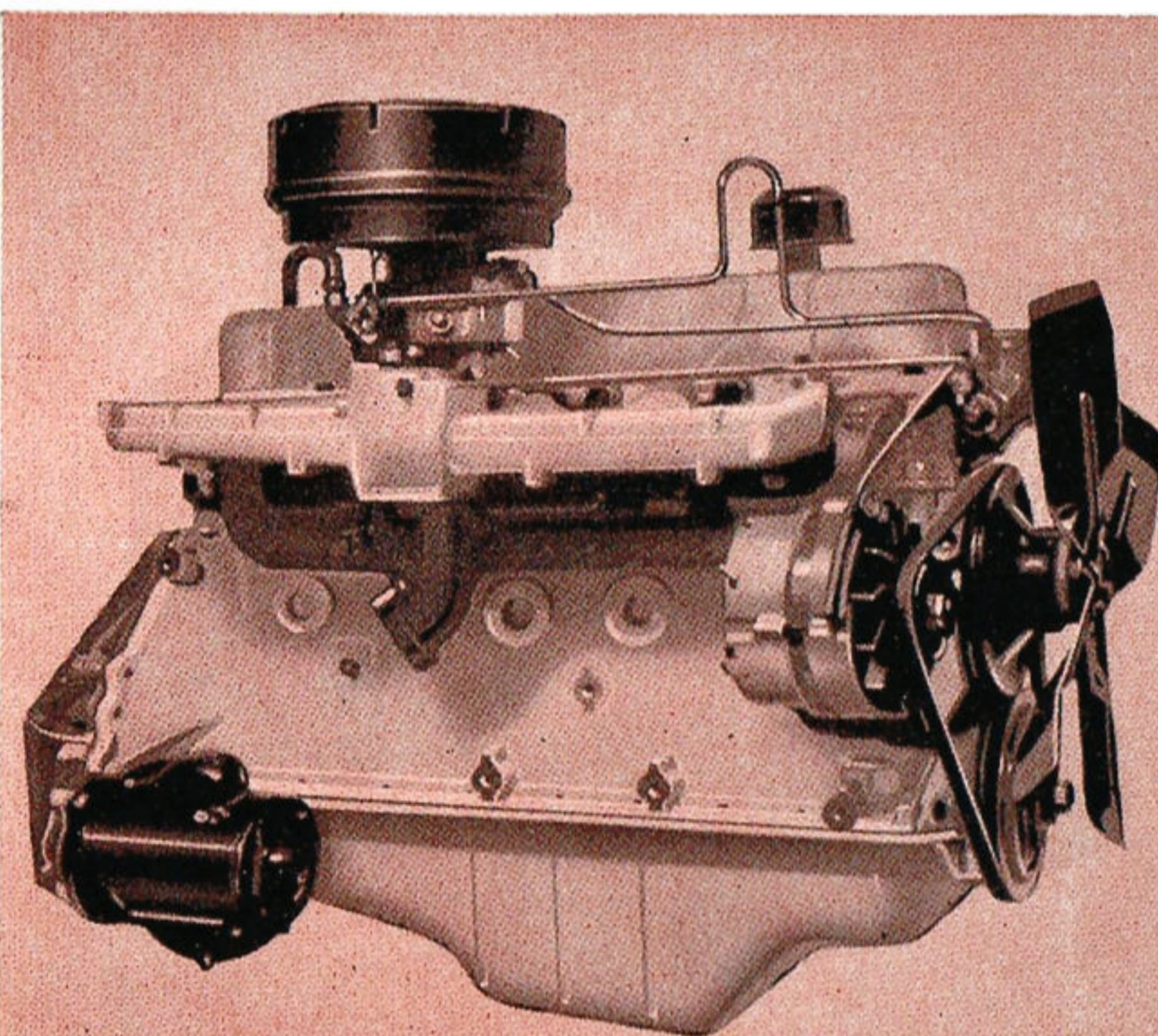
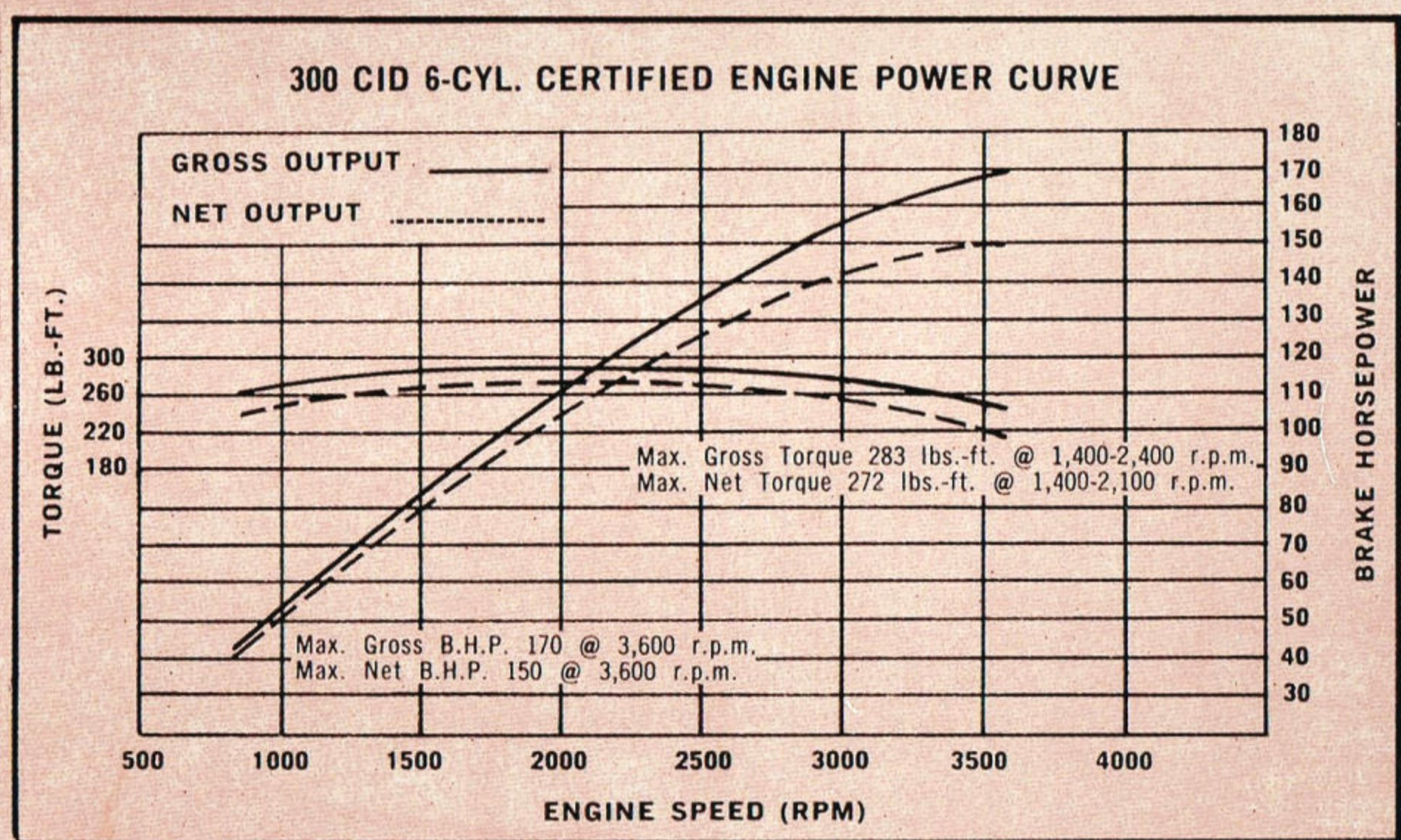

## 9 reasons why F700 is king of the 23,000 lbs. GVW class

### 2. HEAVY-DUTY 5-SP TRANSMISSION

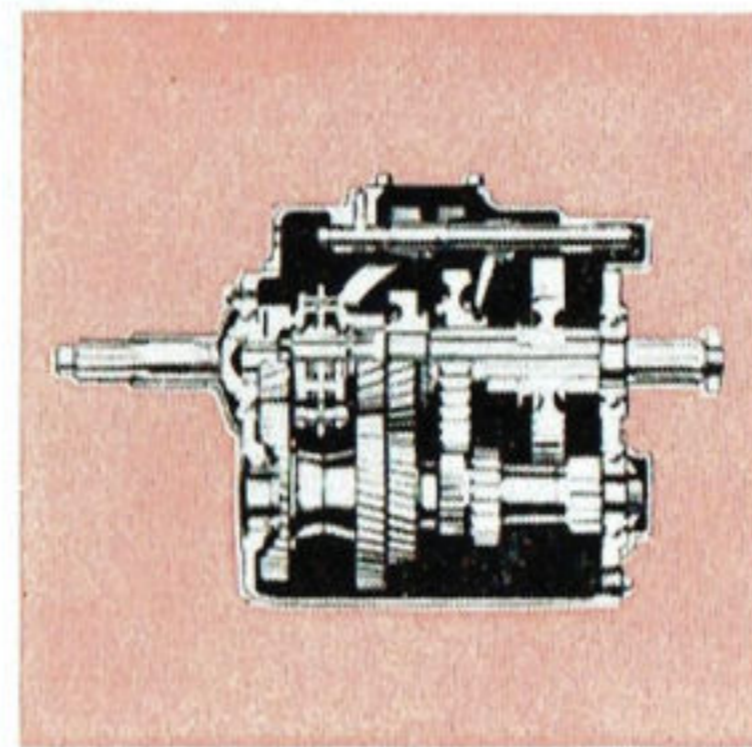

Ford F 700's extra capacity Clark 250V heavy-duty transmission is standard equipment. It has five forward and one reverse speed with synchromesh on fourth and fifth. Constant mesh helical gears are fitted for the top three speeds. The transmission is one of the most proven in the business; with short gear lever travel in low and reverse.

### 3. RUGGED 6,000 LBS. FRONT AXLE

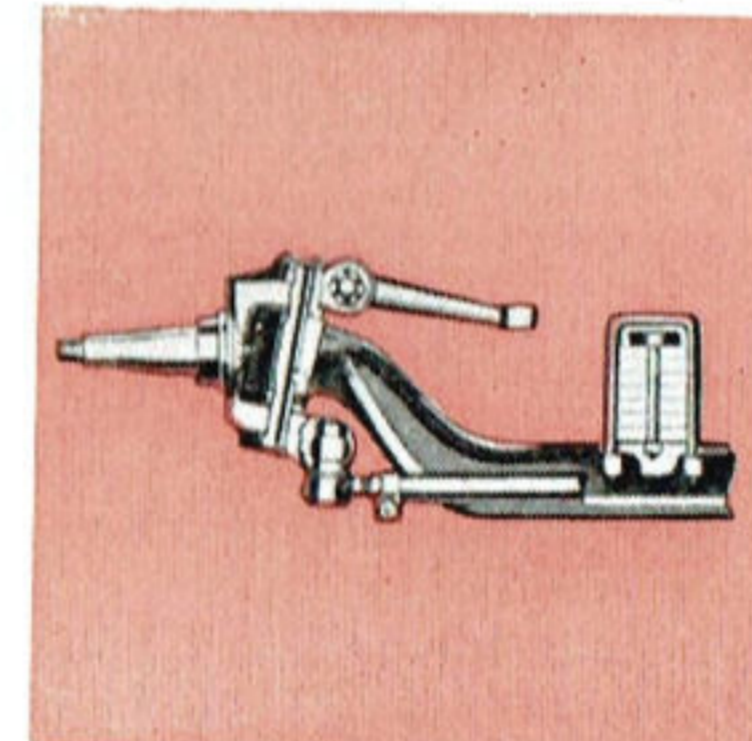

F 700's heat treated high carbon steel front axle has 6,000 lbs. capacity. Its rigid I-Beam construction has extra strength at stress-points, and delrin acetal resin kingpin bushings reduce friction and wear. There's big strength in steering arms, knuckles and kingpins. Illustrated from rear of truck, looking forward.

### 4. BIG CAPACITY RADIUS-LEAF SPRINGS

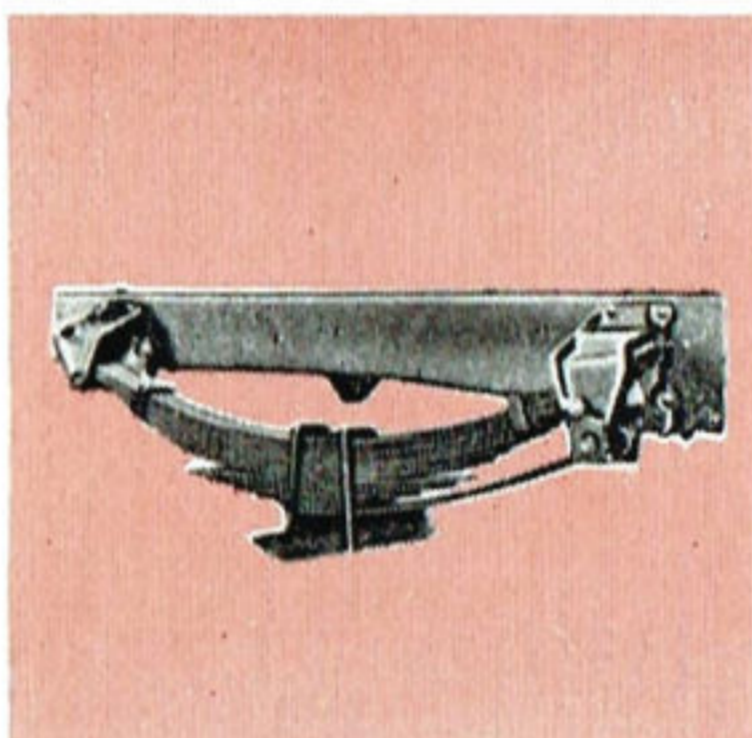

Front springs, of 2,700 lbs. capacity at pad are wide-span semi elliptics with low deflection rate. Rear semi-elliptic springs of 8,100 lbs. capacity use radius leaves to take driving thrust. This allows the main springs to perform their correct function, with desirable riding qualities and stability. They are built stronger, too.

### 5. HEAVY-DUTY 17,000 LBS. REAR AXLE

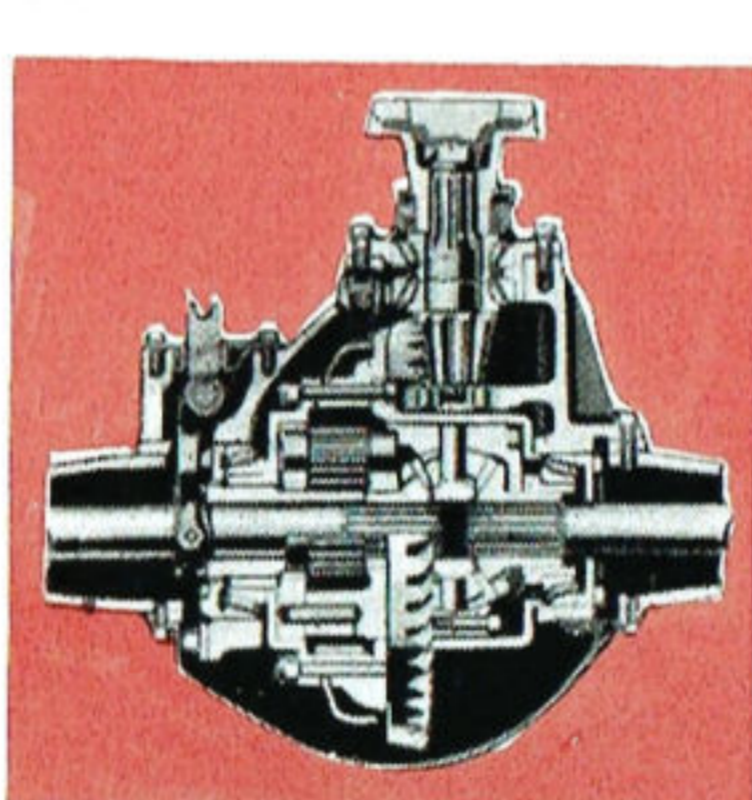

An extra-capacity 17,000 lbs. Eaton spiral bevel full-floating 2-speed rear axle allows a combination of 10 forward and 2 reverse speeds. The 6.50:1 ratio, in high, is ideal for high speeds and light loads, while the 9.04: reduction is for maximum pull for heavy-load work, on steep grades. Here is real rear axle toughness.

### 6. RESERVE BRAKE POWER WITH BIG BOOST

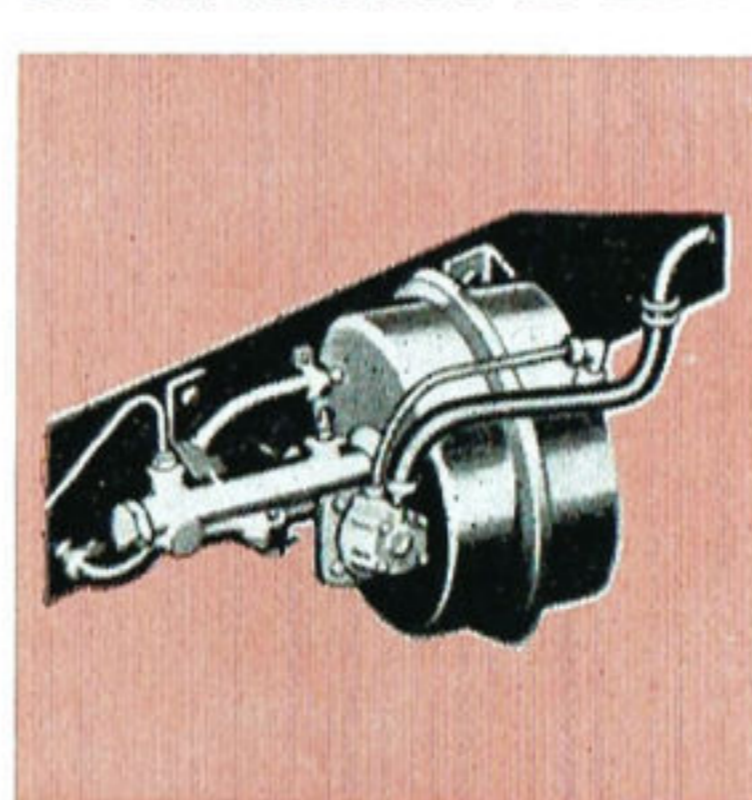

Heavy duty hydraulic brakes have a total drum lining area of 459.46 sq. inches. A big 12 3/4 in. diameter vacuum boost gives great assistance to the operator, reducing fatigue, and keeping brake fade to a minimum under full load conditions. Internal shoe parking brake supplements 4-wheel brakes, giving security while stationary.

### 7. TOUGH, HEAVY LADDER-TYPE FRAME

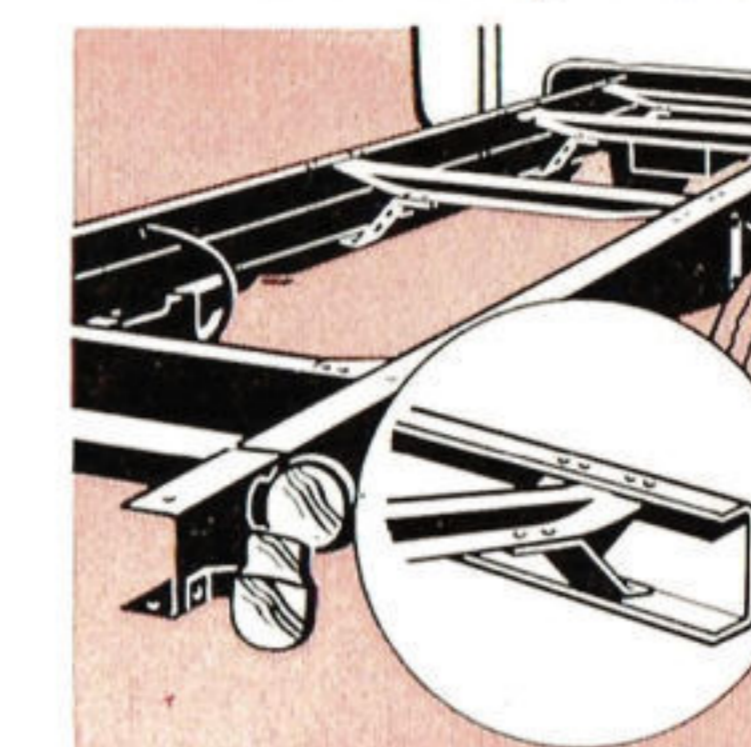

F 700's heavy gauge steel ladder-type frame has cross-members with alligator jaw attachment to side rails. Standard S.A.E. "X" width facilitates fitting of standard or custom-built bodies. The extra strength built into the construction of F700's frame gives great rigidity, durability and payload capacity where it counts most.

Wheelbase	Max. Side Rail Section	Section Modulus	Number of Cross Members
156", 174"	9.31 x 2.97 x 0.28	18.0	156", 174" 6
194"	Inverted L side member reinforcement 9.56 x 3.22 x 0.25		194" 7

### 8. IMPROVED CAB MOUNTINGS

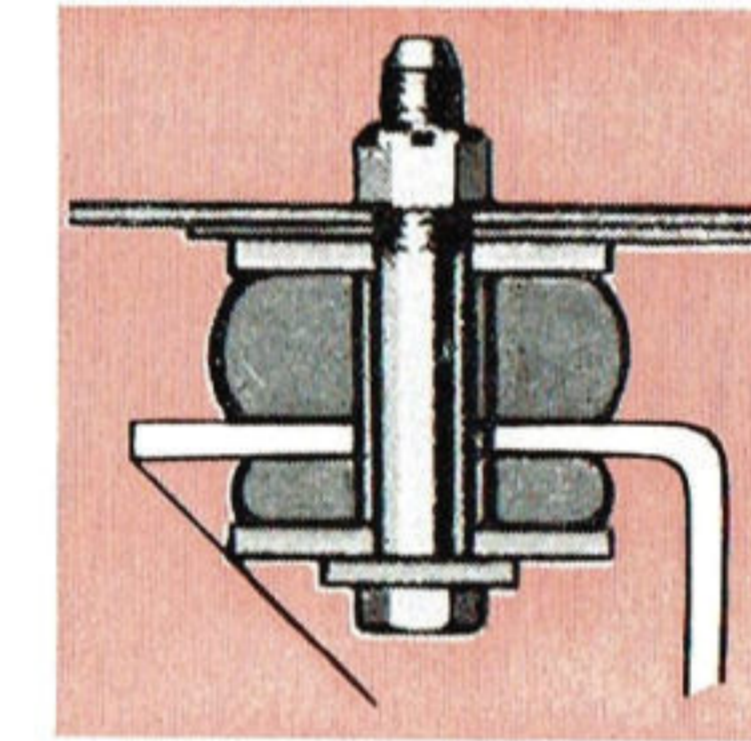

The system of rubber-cushioned 4-point cab mountings on Ford F-series trucks provide a better ride, and insulate the cab against frame stresses and vibration, reducing sheet-metal strains. The cab mountings accordingly improve the operator's comfort and increase cab life. Get into F700's cab and try it for yourself.

### 9. CAB VISIBILITY AND COMFORT

The new F 700 cab is wide, with low step height to the ground. It has plenty of room for three big men, and visibility is excellent, with a total of 2,800 square inches of safety glass around you.

Everything is there for comfort, safety and convenience. Four point rubber cushioned cab mounts reduce cab vibration and stresses on metal-work. It's designed to ease the work.

1. 1280 sq. inches of safety glass windscreen.
2. 4 1/2" seat adjustment.
3. All-weather safety step.
4. Wide doors, with door checks make for easy entry and exit.

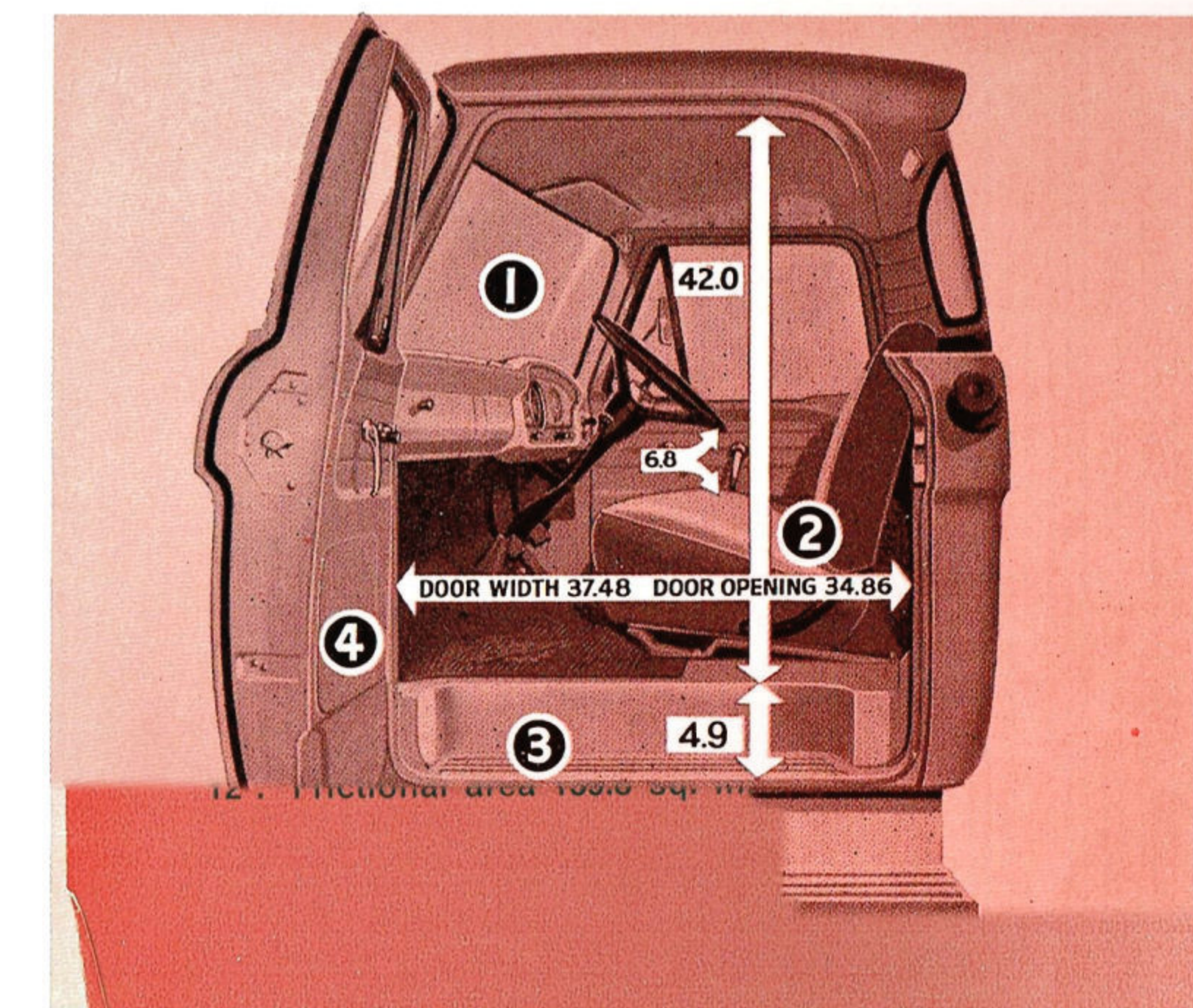

# NEW FORD F700

CHASSIS DIMENSIONS

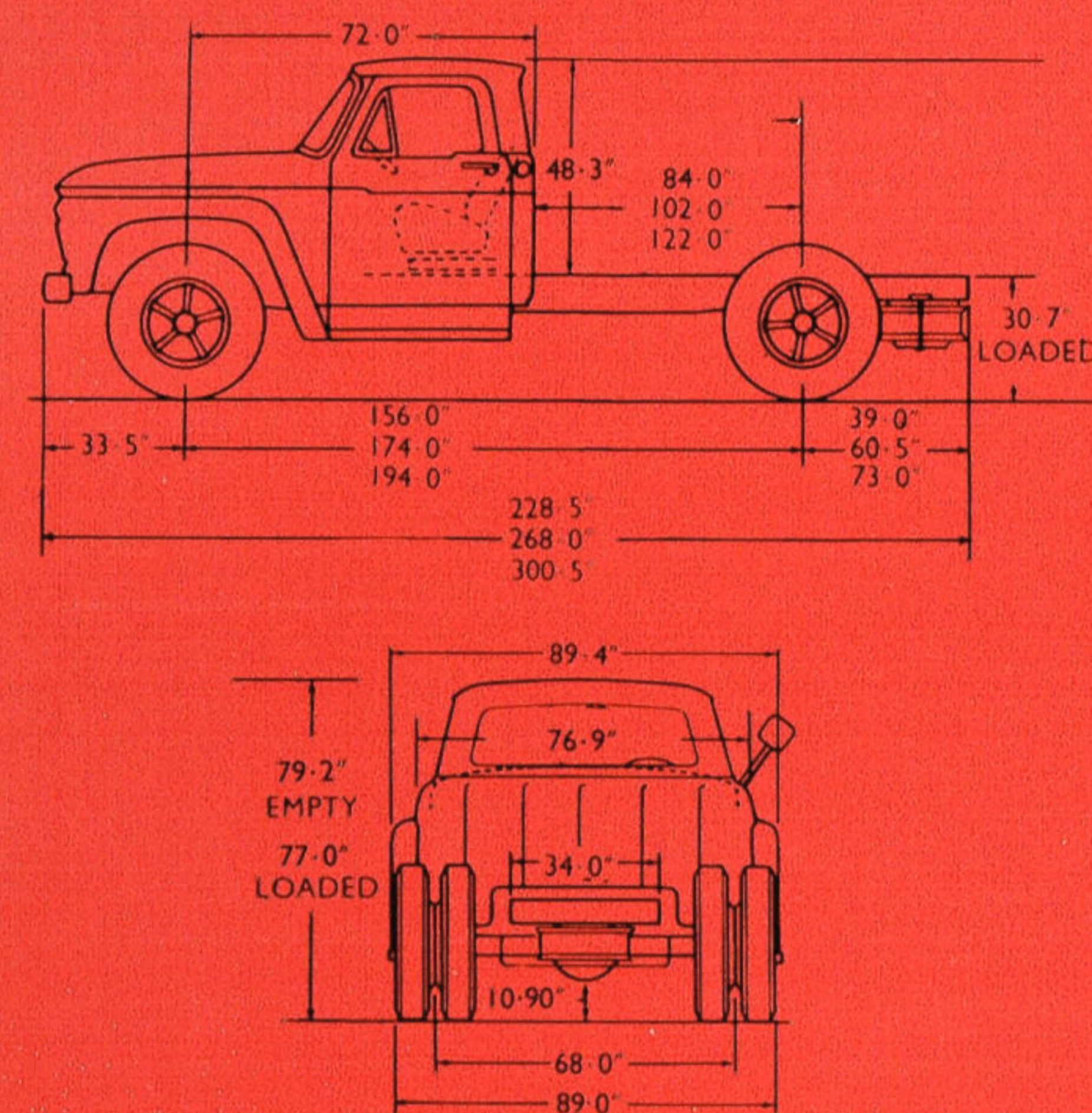

### WEIGHT RATINGS

(GVW's approximate, including fuel, oil and water)

156" W/Base	Front	2,932 lbs
	Rear	2,772 lbs
	Total	5,704 lbs
Approx. weight available for payload and equipment 17,296 lbs		
174" W/Base	Front	2,989 lbs
	Rear	2,818 lbs
	Total	5,807 lbs
Approx. weight available for payload and equipment 17,193 lbs		
194" W/Base	Front	3,051 lbs
	Rear	2,881 lbs
	Total	5,932 lbs
Approx. weight available for payload and equipment 17,068 lbs		

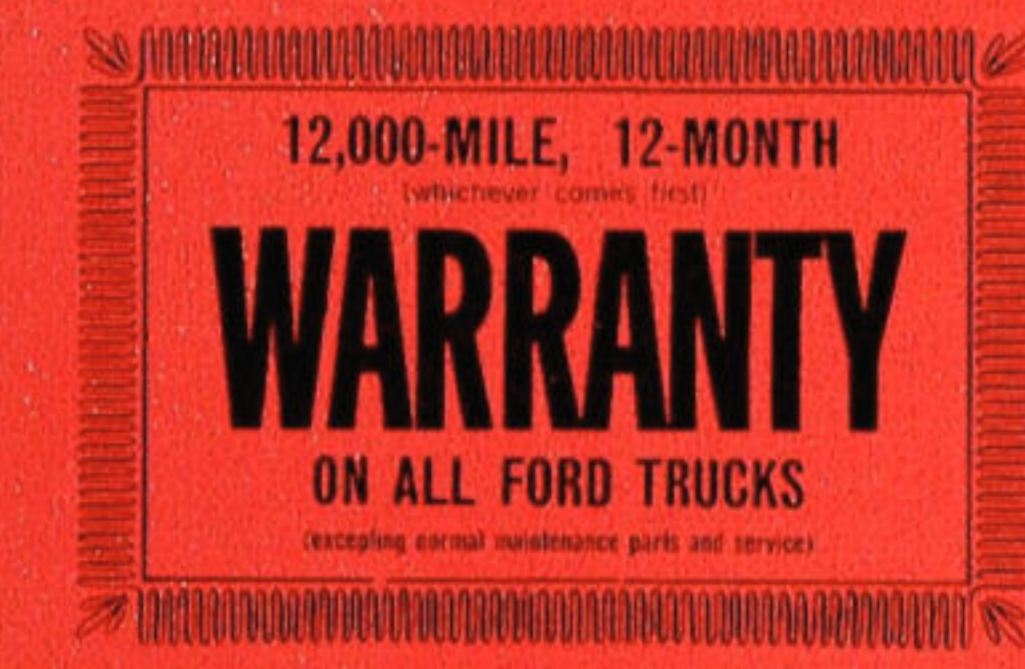

Ford Trucks give you warranty protection for 12,000 miles or 12 months, whichever comes first. Every Ford Truck is warranted against defects in materials and workmanship for this extended period. Owners are responsible only for normal maintenance items. This big extra owner-benefit is provided without any increase in the low prices of Ford trucks.