



VALIANT  
*Galant*



## A good look at two good-looking cars

You see above the Galant 1500 Deluxe and the standard Galant. Just two of the four-model Galant range. All share the Dyna Wedge shape – and hop-up rear fender line that not only contributes to appearance but passengers and luggage space.

We've kept the shape simple, with recessed door handles and ventless window glass. Which looks good if you're outside looking in – and helps visibility if you're inside looking out.

We designed wrap-around turn-indicators just to be on the safe side.

The 1500 deluxe, closest to us, includes wheel trim rings, chrome sill and belt mouldings and whitewall tyres to set off the whole effect.

Poised just behind the Deluxe is the standard Galant. Here's a good view of the crisp, contemporary Galant profile.

It's this simple. Valiant Galant is the best appointed, best equipped car for the money.

Here's a list of features that show in the cars but not in the pictures: Illuminated consolette. Concealed trunk-lid radio aerial. Courtesy light. 2-speed

wipers. Interior rearview mirror. Automatic choke. Remote-control bonnet lock. Radiator pressure release valve. And more. (Over 70 standard safety features, for example.)

Drive the Galants soon, at your Chrysler/Valiant Dealer. And when you

do, remember one final point.

You'll never have a problem finding parts or service. Not with 390 Chrysler/Valiant Dealers to serve you, across the nation.



## Interiors that are worth looking into

Here are some of the main interior features found in all four Galants — the Galant, Galant Deluxe, Galant 1500 Deluxe and Galant 1500 Deluxe Automatic. Just before you hop in, notice: Four doors, a big feature on a small car.

And look, armrests on every door. As well as soft-handled window winders.

While the courtesy light is on, look

down. That's full carpeting, if it's one of the Deluxe models. A carpet/vinyl combination is standard on the Galant.

Funny, you don't feel closed in once the door's shut. Curved side glass gives plenty of shoulder room. Leg room's as generous as you need. The front bucket seats travel fore and aft.

That supple upholstery is easy-to-clean

vinyl stretched over plump urethane foam that moulds itself to your shape.

It would be easy for a car this well-equipped to get cluttered. But look around. Everything's there — tucked away neatly and conveniently.

That's the thing about Galant. We've done it all, and done it right.



## A small car that's big on equipment

- Standard full-synchro floor shift.
- Adjustable tilt steering wheel.
- Multi-use lever for fingertip operation of turn indicators, twin-jet windshield washers, wipers and dip switch.
- Push-button glove box and face-level air vents (flow-through ventilation.)
- Push-button 11 transistor radio (1500 Deluxe), cigar lighter and hand heater-demister controls (standard all models).
- Ignition/steering column lock with two-way key.
- Lockable fuel cover.
- Hub caps (standard all models), trim rings and whitewall tyres (Deluxe models).
- 3-speed automatic "T-bar shifter" (1500 Deluxe).
- Standard front disc brakes (1500 Deluxe).
- Floor-mounted hand brake.
- Exterior rearview mirror.
- Dash layout with easy-to-read instruments. (Those two red lights on the left are saying a door is open and the hand brake's on.)
- Standard model vinyl seat upholstery over urethane foam.
- Large flat boot.
- Distinctive tail lamp, housing (in order from left): Reversing light, tail and brake lights, and the turn indicator light.

# Engineering

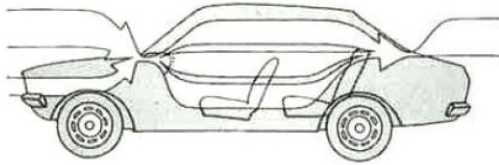

Galant's all-weather flow-through ventilation system changes the cabin air every 10 minutes. Keeps the atmosphere (and the driver's head) clear, even on rainy days.

Galant's 95hp, 1500cc or 87hp, 1300cc Hemi Saturn engines feature high overhead camshaft; lightweight head; minimum-surface combustion chambers; 5-bearing crankshaft; water-heated intake manifold; dual exhausts. They're the strongest, most economical little brutes ever lowered into a small car.

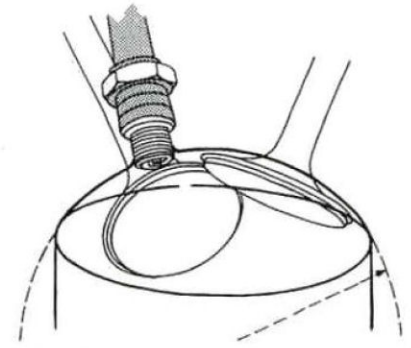
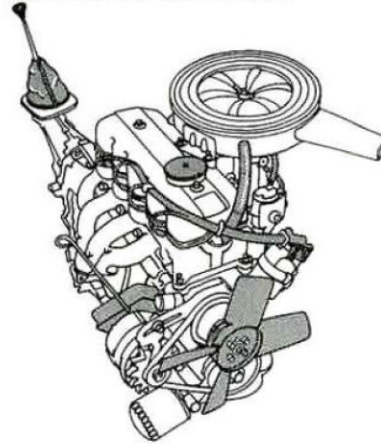

What does Hemi mean? Hemispherical combustion chambers allow more complete and even burning of fuel. So you get maximum power output—and the best performance in Galant's price class.

Galant engines also feature a cross flow intake/exhaust system. Strong turbulence created by this system gives a more thorough mixing of air and fuel. Combustion is complete, with virtually no waste or carbon deposits.

# Specifications

**Engine (General):** 4-cycle, 4-cylinder in-line with overhead camshaft, lightweight cross-flow head; Crankshaft and camshaft mounted in 5 bearings; Hemispherical, minimum-surface combustion chamber.

**Galant 1300:** Bore x stroke, 2.876 ins x 3.033 ins. Piston displacement: 1,289 cc. Compression ratio, 9.0 : 1. Maximum output, 87 hp at 6,300 r.p.m. (S.A.E.).

**Galant 1500:** Bore x stroke, 2.935 ins x 3.388 ins. Piston displacement: 1,499 cc. Compression ratio, 9.0 : 1. Maximum output, 95 hp at 6,300 r.p.m. (S.A.E.).

**Fuel System:** Down-draught, two-barrel carburettor with mechanical diaphragm pump. Fuel tank capacity, 9.9 gals.

**Lubrication System:** Force-feed by trochoid pump. Paper-element oil filter. Crankcase capacity, 6.2 pints.

**Cooling System:** Pressurized radiator with centrifugal pump and fan. (Circulation

controlled by thermostat.) Water capacity, 1.32 gals (1300); 1.36 gals (1500).

**Ignition System:** Coil and distributor with mechanical and vacuum control.

**Electrical System:** 12-volt, 28-amp., alternator; 12-40 ampere-hour battery.

**Clutch:** Single dry-plate clutch with hydraulic actuation.

**Transmission:** Manual: 4-speed, floor-mounted, synchromesh in all forward gears. 1st, 3.52 : 1; 2nd, 2.93 : 1, 3rd, 1.442 : 1; 4th, 1.000 : 1; reverse, 3.867 : 1.

Automatic: 3-speed, floor-mounted with manual over-ride. 1st, 2.393 : 1; 2nd, 1.450 : 1; 3rd, 1.000 : 1; reverse, 2.094 : 1.

**Rear Axle:** Semi-floating axle. Hypoid bevel final drive. Gear ratio 4.222 : 1 (1300), 3.889 : 1 (1500).

**Suspension:** Front: Independent, strut-type with double-acting shock absorbers.

Anti-roll bar. Rear: Semi-elliptic leaf springs with double-acting shock absorbers.

**Brakes:** 1300—Hydraulic, two leading shoe, 9" diam., front drum brakes. Leading-trailing shoe, 8" diam. rear drum brakes. Total lining area 95.4 sq. ins. 1500—Hydraulic, front disc brakes. Leading-trailing shoe 8" diam., rear drum brakes. Tandem master cylinder. Parking brake operates mechanically on rear wheels.

**Steering:** Recirculating ball type with variable ratio gear. Gear ratio, 15.58-18.18. Tilt steering wheel. Minimum turning circle, 30.2 feet.

**Wheels and Tyres:** Pressed-steel disc wheels; 6.15 x 13 x 4 P.R. Tyres.

**Dimensions:** Overall length, 159.8 ins. Overall width, 61.4 ins. Overall height, 54.5 ins. Wheelbase, 95.3 ins.

**Weight:** 1960 lbs. approx.

# Nationwide Parts and Service

Now, finding service and spare parts for your Galant is a simple matter. It's as near as your nearest Chrysler/Valiant dealer.

There are more than 390 of them across the nation—the biggest dealer network for any Japanese car in Australia. With factory trained technicians to take care of your car, and a complete stock of genuine Chrysler replacement parts and panels on hand.

So no matter where you go in your Galant, you can always be sure of finding friendly, capable service.

Just look for the Chrysler sign.

The policy of Chrysler Australia Limited is one of continual improvement in design and manufacture wherever possible to assure a still finer car. Hence specifications, equipment and prices are subject to change without notice.

