



CARGO





A Word About This Catalog: Some equipment shown or described in the catalog is available at extra cost.

Ford CARGO An Investment In Value



Low Cost Of Ownership

From the heavy-duty, mid-range Ford Diesel engine, to the ease of service built into its tilt-cab design, economy of operation is a fact of trucking life with CARGO. Impressive payload capacities decrease handling costs per unit of loading. And tight maneuverability—51.3 foot turning diameter (w/153" wheelbase)—means outstanding performance plus fast trip times.

Ford Diesel Power

CARGO quality begins with power. Ford Diesel Power. The Ford Diesel engine features a Garrett turbo-charger for improved power, a Bosch direct high pressure injection fuel pump for precise fuel delivery at all engine speeds and an advanced air management and combustion system for enhanced fuel economy.

Work-Ready For Added Value

Ford makes it easy to get the CARGO that's right for you with our "Work-Ready" Program. Choose from over 100 models covering 5 wheelbases, three Ford Diesel engines up to 210 HP*, including select CF-8000 models—new for 1987—with 33 and 36,000 pound GVWR's. Available for quick delivery, pre-engineered Work-Ready trucks are designed to provide you with the powertrain, frame, axles and suspension that best match your vocational needs. And, as an added benefit, they carry Extended Service Coverage—an \$800 manufacturer's suggested retail value.

*SAE J1349

Contents

Tomorrow's Truck From Today's Leader	4-5
Ford Diesel Power	6-9
Work-Ready Trucks	10-11
Components, Chassis Features and Warranty	12-13
Interior	14-15
Service Ease	16-17
Specifications and Standard Equipment	18-19



Ford CARGO--Tomorrow's Truck From Today's Leader

Ford Grabs Low-Tilt Leadership

Ford CARGO—combined with the C-Series—sold more low-tilt cabs in 1986 than any other manufacturer.* More than the Mack Midliner. More than Mercedes. More than GM. More than International. That says a lot for CARGO. Since its introduction it's quickly gained leadership as Ford's fastest growing medium truck line.

Leadership. You could say it's the Ford tradition. A tradition that's made Ford America's medium truck leader. You've come to depend on us. For quality. For toughness. And for value. For the low cost of operation that maximizes your return on dollars spent.

*Based on R.L. Polk & Co. cumulative truck registrations through Oct., 1986.

Tradition Plus Innovation

CARGO combines the best of a long Ford tradition of value with modern engineering innovation to help keep your truck on the road and you in business.

Powered by the Ford Diesel heavy-duty mid-range engine, CARGO has the contemporary look of the new medium truck market. Backed by a vast national parts and service network, CARGO represents tomorrow's level of performance, toughness and low cost of ownership...today.

New For 1987: CARGO CF-8000

New for 1987, CARGO CF-8000—powered by the Ford Diesel 185 or 210 HP engine—carries a 33 or 36,000 pound GVWR and is available in four wheelbases from 171-225 inches. Work-Ready models are listed for quick delivery.

Ford-Tough From The Ground Up

CARGO combines the ruggedness of proven chassis components and tight turning diameters for outstanding performance and maneuverability—45° wheel-cut angles provide close

cornering for those tight city streets and loading areas.

Extra long front and rear springs, front stabilizer bar and front shock absorbers produce an uncommonly smooth ride and remarkable handling ease. The tough medium/heavy chassis features straight-through frame rails, clear top flanges and standard 34-inch spacing for easy body mounting.

CARGO Aerodynamics

As much as 50% of the horsepower required to move your truck down the road at legal highway speeds can be spent overcoming wind resistance. CARGO's aerodynamic design cuts through the wind instead of your profits:

- Double curvature windshield
- Spoiler collar to deflect air around the body
- No external drip rails
- Aerodynamically engineered windshield pillars
- Bumper extension end caps
- Aerodynamically shaped mirrors and arms
- Flush door handles to minimize air drag.



Ford—America's Medium Truck Sales Leader

CUMULATIVE REGISTRATIONS x000

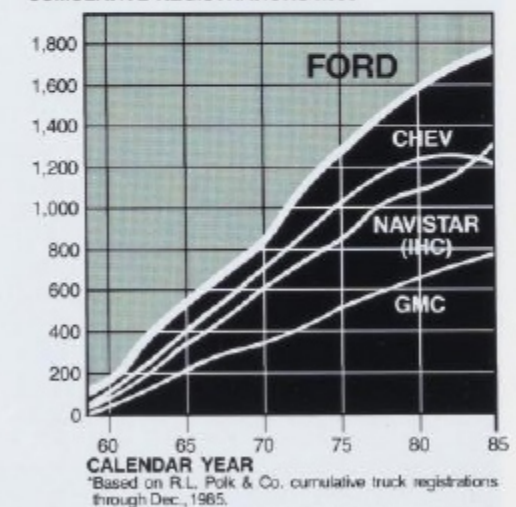

Value Begins With Quality

From its built-tough frame to its contemporary build, CARGO comes out of a long Ford tradition of quality based upon engineering excellence and manufacturing care. With CARGO Ford continues to put quality on the line.

Ford Diesel Power

20 Years And 2,000,000 Diesel Engines Ago

That's how long Ford has been in the heavy-duty diesel engine business.

We've been a pioneer in the development of diesel power since we introduced our first diesel engine in 1965. Our agricultural and industrial diesels have been used in 100 countries since then.

The Ford Diesel is a direct product of that long and proud service history.

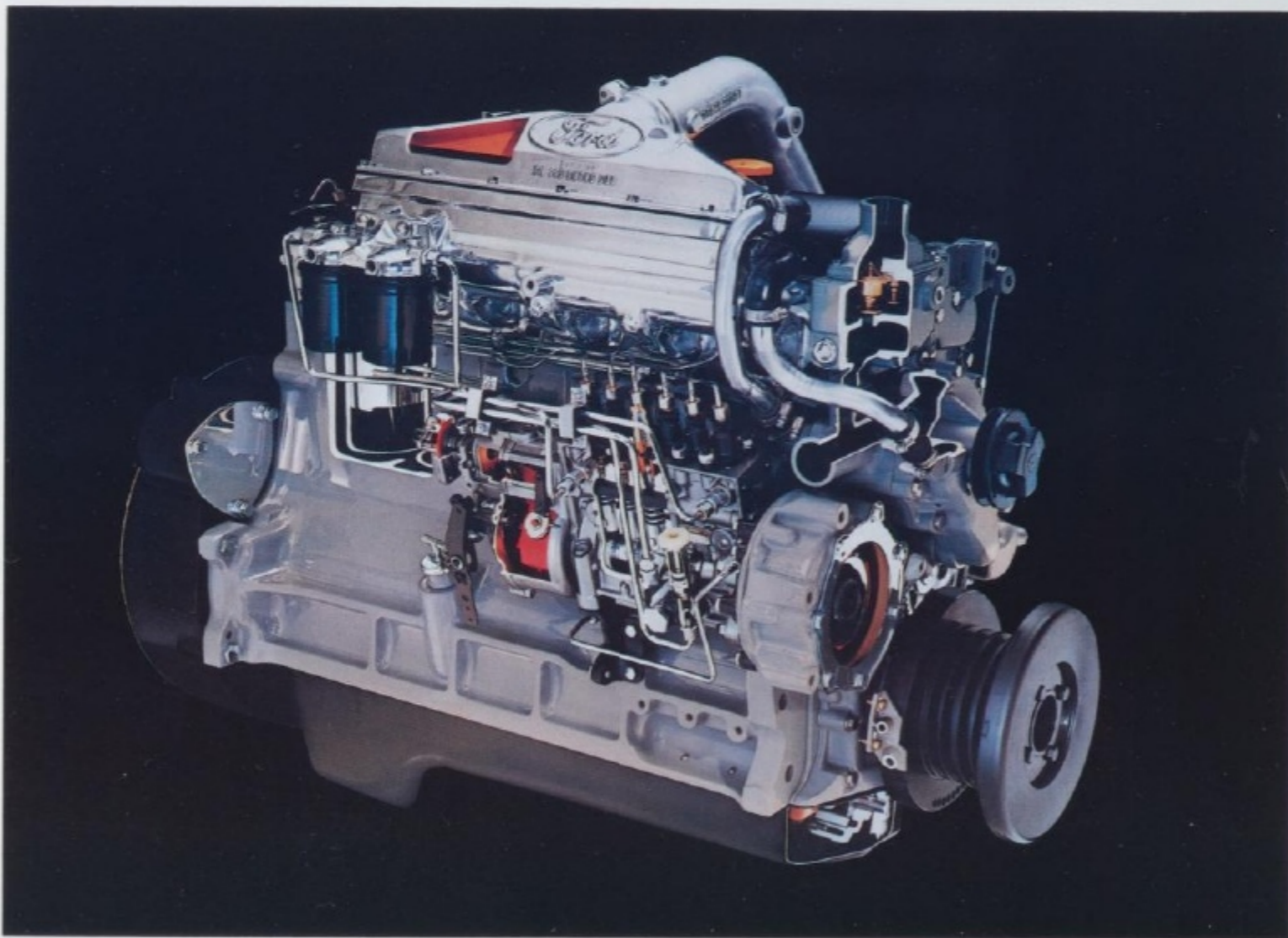

Premium Diesel Performance Without The Price

(A) Stress-Relieved Cast Iron Cylinder Block is built for toughness, excellent heat transfer and cooling. The deep skirt design extends well beneath the crankshaft to maximize rigidity and strength. And its parent-bore construction (a solid iron block, with no sleeves or liners) makes it tough and rebuildable—up to four times to .040 inches.

(B) Stress-Relieved Cast Iron Cylinder Head features 6 large-diameter head bolts per cylinder for efficient and solid clamping of the head gasket.

(C) Stellite-Faced, Chrome-Stem Exhaust Valves offer protection against wear, burning and warping. Used for years in high-performance engines and reciprocating aircraft engines for its resistance to wear at high temperatures, Stellite is an alloy composed largely of chromium and cobalt.

(D) Autothermic Piston Design results in controlled expansion and tight fit within the cylinder for reduced piston "slap" and wear. Two chrome-plated oil-control rings provide excellent oil-retention. The "tight" cast-iron top ring combines excellent wear characteristics with increased combustion pressure and performance.

(E) Forged Alloy Steel Crankshaft is designed for strength. Its 7 main bearings provide an exceptionally large area—26.7 square inches—for enhanced support and bearing life. The induction-hardened journals can be reground up to five times. Dynamic balance decreases vibration and extends bearing life.

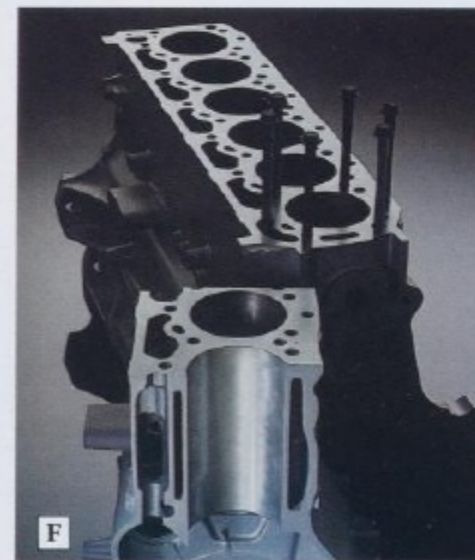
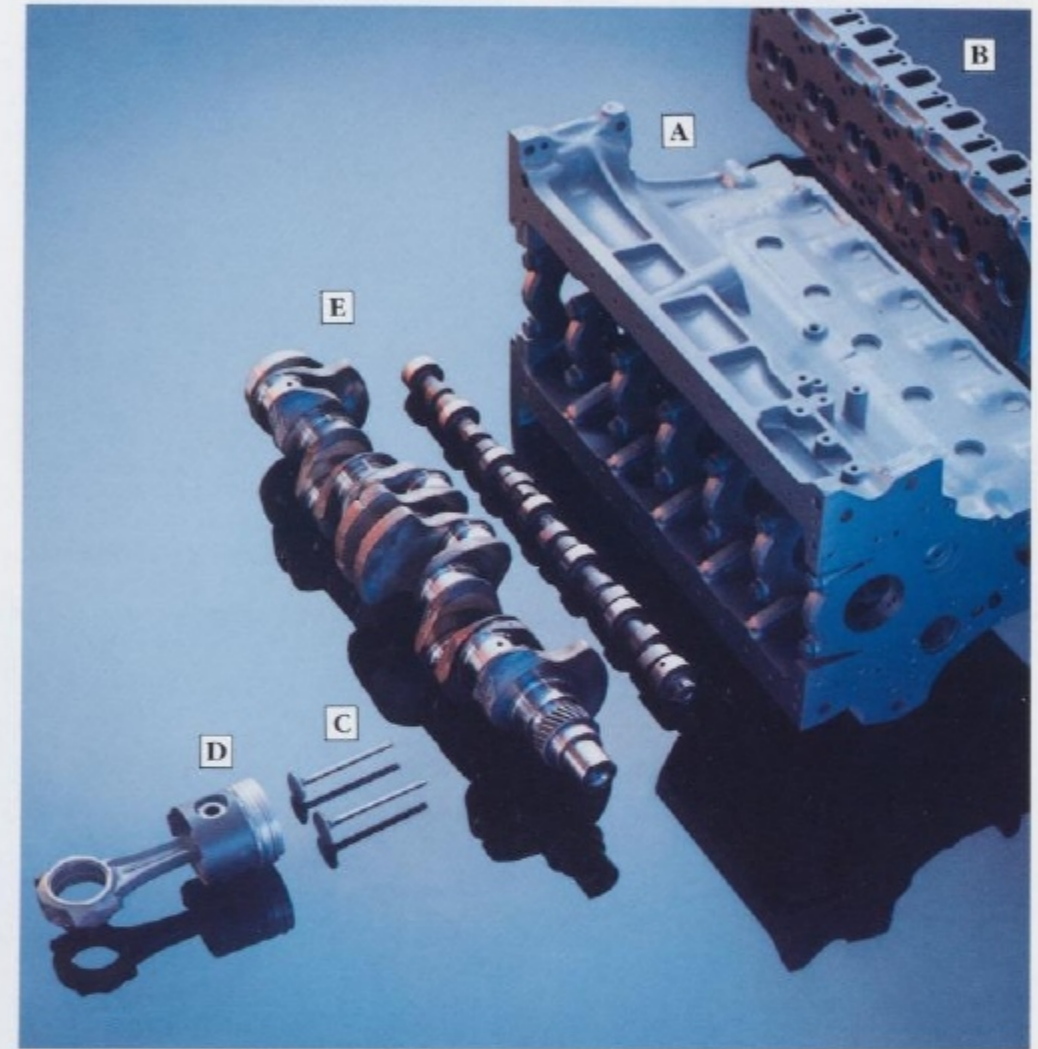

(F) Parent Bore Advantages

The Ford Diesel's parent bore design offers distinct advantages:

- **Strength**—The solid iron, parent bore block actually forms a double cylinder wall compared to the single wall of a wet-liner engine. The result—increased rigidity and wear resistance.
- **Elimination Of Leak Points**—The parent bore engine eliminates the o-rings used at the top and bottom of an inserted wet-sleeve design. Over time, o-rings deteriorate, allowing engine coolant and oil to leak into the cylinders.

Ford Diesel Specifications

General Specifications

ENGINES	170 HP	185 HP*	210 HP*
TYPE AND NUMBER OF CYLINDERS	In-line 6		
AIR INTAKE	Turbocharged		
FUEL SYSTEM	Direct injection		
BORE AND STROKE (INCHES)	4.4 x 4.4	4.40 x 5.20	4.40 x 5.20
DISPLACEMENT (LITERS/CUBIC INCHES)	6.8L/401	7.8L/474	7.8L/474
MAX. GROSS HP (BHP @ RPM) (SAE J1349)	170 @ 2600	185 @ 2600	210 @ 2600
MAX. GROSS TORQUE (LBS. FT. @ RPM)	402 @ 1600	467 @ 1600	509 @ 1600
TORQUE RISE	17%	25%	20%
COMPRESSION RATIO	16.7:1		
ENGINE MOUNTING	3-point rubber		
FUEL PUMP	Bosch, P-Series		
GOVERNOR MAKE	Bosch		
GOVERNOR TYPE	variable speed mech. integ. w/inj. pump		
GOVERNED SPEED (RPM)	2600		
INJECTORS	Bosch		

*N.A. California.

Ford Diesel Performance Pledge

The Ford Diesel is backed by the Ford Diesel Performance Pledge. An added value—at no cost to you.

- 36 months/150,000 miles Extended Service Coverage on the engine.
- 48-hour parts delivery guarantee. Ask your Ford Dealer for details.
- Backed by 600 certified service dealers nationwide.
- Toll-free hotline 1-800-FORD 1ST (367-3178)*

*In Alaska call 1-800-433-6292.



Premium Payback In Mid-Range Operations

Premium Performance Features

The Ford Diesel employs the latest in modern engine technology to provide the kind of performance usually associated only with big-bore diesels.

Premium performance features. Rebuildability. Fuel efficiency. That's Ford Diesel—premium payback in mid-range operations.

(A) Combustion System

Large section inlet and exhaust manifolds, helical-type inlet ports and advanced piston bowl shaping create a highly turbulent air-fuel mixture resulting in very efficient combustion, good fuel economy and exhaust emissions control.

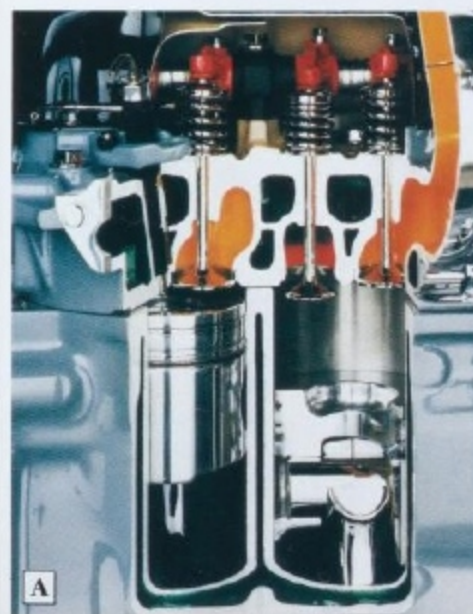

Bosch Direct-Injection Fuel Pump

The Bosch high pressure direct-injection fuel pump has been specifically tailored to provide precise fuel delivery at all engine speeds, resulting in consistent power, good fuel economy and excellent performance. The P-Series pump is normally associated only with linehaul diesels and, therefore, can be expected to provide heavy-duty service.



(B) Garrett Turbocharger

The Garrett turbocharger has been designed and developed as an integral part of the Ford Diesel engine. The exact matching of the turbo with a highly efficient combustion system provides excellent power and torque performance, even at high altitudes.

Ford Diesel Premium Performance

The Ford Diesel is a high torque rise engine for premium performance, producing remarkable pulling power at low engine speeds. This means easier high climbing with fewer gear changes for less strain on the driver as well as reduced engine wear.

The Garrett turbocharger has been designed for quick response with virtually no power loss at high altitudes, a definite advantage over naturally aspirated engines.

Proven In Fleet Tests—4 Million Miles

Ford Diesel comes out of a proven design. And it's been fleet tested through 4,000,000 miles of tough customer use including pick-up and delivery, construction, inter- and intra-city use.

Proven In Fuel Economy Tests

The results are in. SAE Type II fuel economy tests (conducted by the Transportation Research Center of Ohio, April, 1986) show the Ford Diesel tops in the field. Ford Cargo—powered by the 165 hp Ford Diesel—outperformed comparable GMC, International and Mercedes-Benz trucks—powered by Caterpillar, Mercedes, DDA, and International engines—in head-to-head fuel economy competition. By up to 17%.

Ford Diesel—Fuel Economy Champion

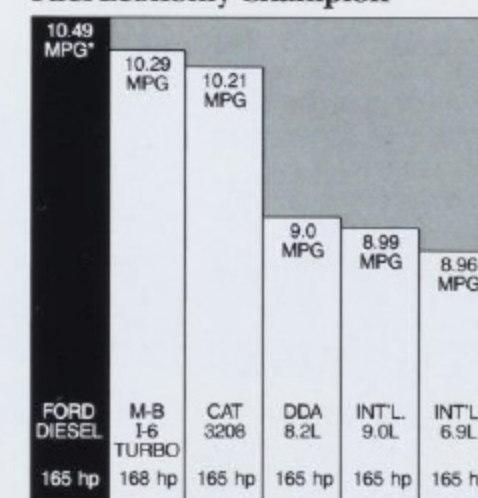

*MPG figures represent the average long/short haul test.

Don't Take Our Word For It—Call Toll-Free 1-800-FORD 1ST (367-3178)*

We think you'll agree. The Ford Diesel has been built to the same high standards of quality and toughness that have helped make Ford America's best selling medium truck line.

But don't take our word for it. We've got the testimonials of "Big Users" and the engine spec sheets to back our claims.

Call toll-free 1-800-FORD 1ST (367-3178)* and we'll send them to you with no obligations.

*In Alaska call 1-800-433-6292.

Note: Chromed and painted engine parts are for display only.

Work-Ready Trucks

Name Your Job... Chances Are We've Already Built Your Truck
You're ready to work. Why wait for a truck that isn't? Waiting for your truck to show up costs time and money. With Ford's Work-Ready Program your ship's already in.

Work-Ready CARGOs are pre-spec'd and ready for quick delivery. They fit the truck to the job, not the job to the truck. They're engineered to provide the powertrain, frame, axle and suspension that best match your needs. And, as an added benefit, they carry Extended Service Coverage.

Extended Service Coverage

An \$800 Value

All CARGO Work-Ready trucks carry Extended Service Coverage (ESC). ESC helps you reduce operating, maintenance and repair costs

ESC Coverage vs. Basic Warranty

Full Parts And Labor For:			
WORK-READY			BASIC WARRANTY
Total Vehicle*	Engine	Powertrain†	
24 Months/ Unlimited Miles	36 Months/ 150,000 Miles‡	36 Months/ 150,000 Miles	12 Months/ Unlimited Miles

*Excludes tires, batteries, maintenance items and all equipment not installed by Ford.
†Includes clutch (except clutch lining), manual transmission, driveshaft and rear axle.
‡Non Work-Ready CARGOs with the Ford Diesel engine also include a no-charge 36 months/150,000 miles engine-only ESC.

by improving your basic warranty protection.

ESC protection covers your basic vehicle for 24 months/unlimited mileage and the Ford Diesel engine for 36 months/150,000 miles. That's an \$800 manufacturer's suggested retail value!



Ford CARGO Work-Ready Performance Packages

When It's Time To Work—Be "Work-Ready!"

Work-Ready Trucks Make Ordering Easy

Ford makes it easy for you to get the right truck for your job through our Work-Ready Program. Tailored specifically to Dump (Construction), Van/Platform, Refuse, Beverage and Tractor applications, Work-Ready trucks are pre-spec'd for ordering ease. And they're available for quick delivery. All CARGO Work-Ready units for 1987 are intended for Cargo/Van application.

Ask a Ford salesperson to help you clearly identify your job requirements. Then select the Work-Ready Performance Package that matches your needs. Ordering is as easy as circling a code number.

Extended Service Coverage—An \$800 Value

Every Ford Work-Ready truck carries Extended Service Coverage (ESC)—full parts and labor for 24 months/unlimited mileage on the total vehicle plus 36 months/150,000 miles on the Ford Diesel engine. Purchased separately, that's a manufacturer's suggested retail value of up to \$800—depending on truck model.

Extended Service Coverage is transferable to any number of owners—within the limits of coverage. It "goes with the truck," making your unit potentially more valuable at trade-in.

ESC Coverage vs. Basic Warranty

Full Parts And Labor For:			
WORK-READY			BASIC WARRANTY
Total Vehicle*	Engine	Powertrain†	
24 Months/ Unlimited Miles	36 Months/ 150,000 Miles‡	36 Months/ 150,000 Miles	12 Months/ Unlimited Miles

*Excludes tires, batteries, maintenance items and all equipment not installed by Ford.
†Includes clutch (except clutch lining), manual transmission, driveshaft and rear axle.
‡Non Work-Ready CARGOs with the Ford Diesel engine also include a no-charge 36 months/150,000 miles engine-only ESC.

Buy Work-Ready... Or Spec It Your Way

Work-Ready may be the easy way to order a truck. But it's not the only way. Ford still builds trucks in the traditional manner—customized to your own set of unique specifications. Ask your Ford Dealer for details. Work-Ready or Custom Built, either way is Ford tough!

Work-Ready Specification Sheets

Here is a sample Work-Ready specification sheet with bullet-points highlighting key areas. The following pages contain selected spec sheets plus a complete listing of the available Packages within the CARGO Series.

- Work-Ready Model Designation Code.

- Line drawing of cab and body with WB/CA dimensions.

- Chassis-Cab Specifications.

CF-6000-704

FOR 18 FOOT BODY

PERFORMANCE DATA		CHASSIS-CAB SPECIFICATIONS	
04	EXTERIOR COLOR: (See Price Book)	04	ENGINE: Ford Diesel (864)
05	WHEEL FRONT: 8.00 x 16 (Std)	05	ENGINE EQUIPMENT: Air Cleaner, Single Stage Oil Filter (Std), Oil Filter, 17" Fuel Filter (Std), 2-Speed Fan, Single 16" Voltage Regulator and Thermostat (Std)
06	WHEEL REAR: 8.00 x 16 (Std)	06	WHEEL WEIGHT: 3600 lbs (Std)
07	AXLE: 17" (Std)	07	DRIVE TRAIN EQUIPMENT: 4-Speed Manual Transmission (Std), 2-Speed Overdrive (Std), 17" Oil Filter, 17" Fuel Filter, Depressible Pedal, 17" Oil Filter (Std)
08	FRONT END: 6,000 lb	08	FRONT END EQUIPMENT: 4-Speed Manual Transmission (Std), 2-Speed Overdrive (Std), 17" Oil Filter, 17" Fuel Filter, Depressible Pedal, 17" Oil Filter (Std)
09	REAR END: 11,000 lb	09	FRONT END WEIGHT: 4,500 lb (Std)
10	TOTAL GVWR: 17,000 lb	10	FRONT END WEIGHT: 4,500 lb (Std)
11	CHASSIS WEIGHT: 4,500 lb	11	FRONT END WEIGHT: 4,500 lb (Std)
12	FRONT: 2,275 lb	12	FRONT END WEIGHT: 4,500 lb (Std)
13	REAR: 8,725 lb	13	FRONT END WEIGHT: 4,500 lb (Std)
14	WHEEL WEIGHT: 3,600 lb	14	FRONT END WEIGHT: 4,500 lb (Std)
15	WHEEL WEIGHT: 3,600 lb	15	FRONT END WEIGHT: 4,500 lb (Std)
16	WHEEL WEIGHT: 3,600 lb	16	FRONT END WEIGHT: 4,500 lb (Std)
17	WHEEL WEIGHT: 3,600 lb	17	FRONT END WEIGHT: 4,500 lb (Std)
18	WHEEL WEIGHT: 3,600 lb	18	FRONT END WEIGHT: 4,500 lb (Std)
19	WHEEL WEIGHT: 3,600 lb	19	FRONT END WEIGHT: 4,500 lb (Std)
20	WHEEL WEIGHT: 3,600 lb	20	FRONT END WEIGHT: 4,500 lb (Std)
21	WHEEL WEIGHT: 3,600 lb	21	FRONT END WEIGHT: 4,500 lb (Std)
22	WHEEL WEIGHT: 3,600 lb	22	FRONT END WEIGHT: 4,500 lb (Std)
23	WHEEL WEIGHT: 3,600 lb	23	FRONT END WEIGHT: 4,500 lb (Std)
24	WHEEL WEIGHT: 3,600 lb	24	FRONT END WEIGHT: 4,500 lb (Std)
25	WHEEL WEIGHT: 3,600 lb	25	FRONT END WEIGHT: 4,500 lb (Std)
26	WHEEL WEIGHT: 3,600 lb	26	FRONT END WEIGHT: 4,500 lb (Std)
27	WHEEL WEIGHT: 3,600 lb	27	FRONT END WEIGHT: 4,500 lb (Std)
28	WHEEL WEIGHT: 3,600 lb	28	FRONT END WEIGHT: 4,500 lb (Std)
29	WHEEL WEIGHT: 3,600 lb	29	FRONT END WEIGHT: 4,500 lb (Std)
30	WHEEL WEIGHT: 3,600 lb	30	FRONT END WEIGHT: 4,500 lb (Std)
31	WHEEL WEIGHT: 3,600 lb	31	FRONT END WEIGHT: 4,500 lb (Std)
32	WHEEL WEIGHT: 3,600 lb	32	FRONT END WEIGHT: 4,500 lb (Std)
33	WHEEL WEIGHT: 3,600 lb	33	FRONT END WEIGHT: 4,500 lb (Std)
34	WHEEL WEIGHT: 3,600 lb	34	FRONT END WEIGHT: 4,500 lb (Std)
35	WHEEL WEIGHT: 3,600 lb	35	FRONT END WEIGHT: 4,500 lb (Std)
36	WHEEL WEIGHT: 3,600 lb	36	FRONT END WEIGHT: 4,500 lb (Std)
37	WHEEL WEIGHT: 3,600 lb	37	FRONT END WEIGHT: 4,500 lb (Std)
38	WHEEL WEIGHT: 3,600 lb	38	FRONT END WEIGHT: 4,500 lb (Std)
39	WHEEL WEIGHT: 3,600 lb	39	FRONT END WEIGHT: 4,500 lb (Std)
40	WHEEL WEIGHT: 3,600 lb	40	FRONT END WEIGHT: 4,500 lb (Std)
41	WHEEL WEIGHT: 3,600 lb	41	FRONT END WEIGHT: 4,500 lb (Std)
42	WHEEL WEIGHT: 3,600 lb	42	FRONT END WEIGHT: 4,500 lb (Std)
43	WHEEL WEIGHT: 3,600 lb	43	FRONT END WEIGHT: 4,500 lb (Std)
44	WHEEL WEIGHT: 3,600 lb	44	FRONT END WEIGHT: 4,500 lb (Std)
45	WHEEL WEIGHT: 3,600 lb	45	FRONT END WEIGHT: 4,500 lb (Std)
46	WHEEL WEIGHT: 3,600 lb	46	FRONT END WEIGHT: 4,500 lb (Std)
47	WHEEL WEIGHT: 3,600 lb	47	FRONT END WEIGHT: 4,500 lb (Std)
48	WHEEL WEIGHT: 3,600 lb	48	FRONT END WEIGHT: 4,500 lb (Std)
49	WHEEL WEIGHT: 3,600 lb	49	FRONT END WEIGHT: 4,500 lb (Std)
50	WHEEL WEIGHT: 3,600 lb	50	FRONT END WEIGHT: 4,500 lb (Std)
51	WHEEL WEIGHT: 3,600 lb	51	FRONT END WEIGHT: 4,500 lb (Std)
52	WHEEL WEIGHT: 3,600 lb	52	FRONT END WEIGHT: 4,500 lb (Std)
53	WHEEL WEIGHT: 3,600 lb	53	FRONT END WEIGHT: 4,500 lb (Std)
54	WHEEL WEIGHT: 3,600 lb	54	FRONT END WEIGHT: 4,500 lb (Std)
55	WHEEL WEIGHT: 3,600 lb	55	FRONT END WEIGHT: 4,500 lb (Std)
56	WHEEL WEIGHT: 3,600 lb	56	FRONT END WEIGHT: 4,500 lb (Std)
57	WHEEL WEIGHT: 3,600 lb	57	FRONT END WEIGHT: 4,500 lb (Std)
58	WHEEL WEIGHT: 3,600 lb	58	FRONT END WEIGHT: 4,500 lb (Std)
59	WHEEL WEIGHT: 3,600 lb	59	FRONT END WEIGHT: 4,500 lb (Std)
60	WHEEL WEIGHT: 3,600 lb	60	FRONT END WEIGHT: 4,500 lb (Std)
61	WHEEL WEIGHT: 3,600 lb	61	FRONT END WEIGHT: 4,500 lb (Std)
62	WHEEL WEIGHT: 3,600 lb	62	FRONT END WEIGHT: 4,500 lb (Std)
63	WHEEL WEIGHT: 3,600 lb	63	FRONT END WEIGHT: 4,500 lb (Std)
64	WHEEL WEIGHT: 3,600 lb	64	FRONT END WEIGHT: 4,500 lb (Std)
65	WHEEL WEIGHT: 3,600 lb	65	FRONT END WEIGHT: 4,500 lb (Std)
66	WHEEL WEIGHT: 3,600 lb	66	FRONT END WEIGHT: 4,500 lb (Std)
67	WHEEL WEIGHT: 3,600 lb	67	FRONT END WEIGHT: 4,500 lb (Std)
68	WHEEL WEIGHT: 3,600 lb	68	FRONT END WEIGHT: 4,500 lb (Std)
69	WHEEL WEIGHT: 3,600 lb	69	FRONT END WEIGHT: 4,500 lb (Std)
70	WHEEL WEIGHT: 3,600 lb	70	FRONT END WEIGHT: 4,500 lb (Std)
71	WHEEL WEIGHT: 3,600 lb	71	FRONT END WEIGHT: 4,500 lb (Std)
72	WHEEL WEIGHT: 3,600 lb	72	FRONT END WEIGHT: 4,500 lb (Std)
73	WHEEL WEIGHT: 3,600 lb	73	FRONT END WEIGHT: 4,500 lb (Std)
74	WHEEL WEIGHT: 3,600 lb	74	FRONT END WEIGHT: 4,500 lb (Std)
75	WHEEL WEIGHT: 3,600 lb	75	FRONT END WEIGHT: 4,500 lb (Std)
76	WHEEL WEIGHT: 3,600 lb	76	FRONT END WEIGHT: 4,500 lb (Std)
77	WHEEL WEIGHT: 3,600 lb	77	FRONT END WEIGHT: 4,500 lb (Std)
78	WHEEL WEIGHT: 3,600 lb	78	FRONT END WEIGHT: 4,500 lb (Std)
79	WHEEL WEIGHT: 3,600 lb	79	FRONT END WEIGHT: 4,500 lb (Std)
80	WHEEL WEIGHT: 3,600 lb	80	FRONT END WEIGHT: 4,500 lb (Std)
81	WHEEL WEIGHT: 3,600 lb	81	FRONT END WEIGHT: 4,500 lb (Std)
82	WHEEL WEIGHT: 3,600 lb	82	FRONT END WEIGHT: 4,500 lb (Std)
83	WHEEL WEIGHT: 3,600 lb	83	FRONT END WEIGHT: 4,500 lb (Std)
84	WHEEL WEIGHT: 3,600 lb	84	FRONT END WEIGHT: 4,500 lb (Std)
85	WHEEL WEIGHT: 3,600 lb	85	FRONT END WEIGHT: 4,500 lb (Std)
86	WHEEL WEIGHT: 3,600 lb	86	FRONT END WEIGHT: 4,500 lb (Std)
87	WHEEL WEIGHT: 3,600 lb	87	FRONT END WEIGHT: 4,500 lb (Std)
88	WHEEL WEIGHT: 3,600 lb	88	FRONT END WEIGHT: 4,500 lb (Std)
89	WHEEL WEIGHT: 3,600 lb	89	FRONT END WEIGHT: 4,500 lb (Std)
90	WHEEL WEIGHT: 3,600 lb	90	FRONT END WEIGHT: 4,500 lb (Std)
91	WHEEL WEIGHT: 3,600 lb	91	FRONT END WEIGHT: 4,500 lb (Std)
92	WHEEL WEIGHT: 3,600 lb	92	FRONT END WEIGHT: 4,500 lb (Std)
93	WHEEL WEIGHT: 3,600 lb	93	FRONT END WEIGHT: 4,500 lb (Std)
94	WHEEL WEIGHT: 3,600 lb	94	FRONT END WEIGHT: 4,500 lb (Std)
95	WHEEL WEIGHT: 3,600 lb	95	FRONT END WEIGHT: 4,500 lb (Std)
96	WHEEL WEIGHT: 3,600 lb	96	FRONT END WEIGHT: 4,500 lb (Std)
97	WHEEL WEIGHT: 3,600 lb	97	FRONT END WEIGHT: 4,500 lb (Std)
98	WHEEL WEIGHT: 3,600 lb	98	FRONT END WEIGHT: 4,500 lb (Std)
99	WHEEL WEIGHT: 3,600 lb	99	FRONT END WEIGHT: 4,500 lb (Std)
100	WHEEL WEIGHT: 3,600 lb	100	FRONT END WEIGHT: 4,500 lb (Std)

- Suggested body type and length.

- Front, Rear and Total Chassis Weights with indicated specifications.

- Weight Distribution.

- Drivetrain Performance.

CF-6000-704



CA: 141 in.
WB: 171 in.

Front GAWR: 9,000 lb.
Rear GAWR: 17,500 lb.
Total GVWR: 26,500 lb.

CHASSIS WEIGHT
Front: 6,359 lb.
Rear: 3,374 lb.
Total: 9,733 lb.

PERFORMANCE DATA
BODY PAYLOAD
WEIGHT DISTRIBUTION (Water Level Loading)
Front: (21%)
Rear: (79%)
Total: (100%)

DRIVETRAIN PERFORMANCE
Gradeability: 30%
Geared Speed: 66 MPH
Total Reduction: 44:1

FOR 18 FOOT BODY

Chassis-Cab Specifications					
08	94	EXTERIOR COLOR: Diamond White (Std.)	30	CD	ENGINE: Ford Diesel (Std.) (170 HP) @ 2600 RPM
10	AG	AXLE, FRONT: 9,000 lb. (Std.)	36	36	ENGINE EQUIPMENT: Air Cleaner, Single Stage Dry Type (Std.) Clutch, 14" 1-Plate, Full Type (Std.) Exhaust System, Single Horizontal Muffler and Pipe-LH (Std.) Fuel/Water Separator (Std.) Oil Cooler-Engine Mounted (Std.) Oil Filter-Two, 1-1/2 Qt. Full Flow, Disposable (Std.) Radiator-643 Sq. In. (Std.)
11	W7	AXLE, REAR: Rockwell, RS-17-220 (4.56/6.36) 17,500 lb.	37	37	ENGINE EQUIPMENT: (Cont'd) Fan Clutch Viscous (Std.) Gauge, Air Cleaner Restriction Indicator (Std.) Throttle, Hand Control (Std.)
13	13	AXLE EQUIPMENT: Mag. Top Fill & Drain Plugs (Std.) Power Steering, 20" Soft-Fee, Locking Steering Wheel (Std.) Shock Absorbers, Front (Std.) Stabilizer Bar, Front (Std.) Wheel Seals, Front, Unized (Std.) Wheel Seals, Rear, Two-Piece Wet-Type (Std.)	40	40	FRAME: 10.2 SM-50,000 PSI Single Channel (Std.) (N.A. for OH-Highway Service)
16	HD	BRAKES, SERVICE: Split Power-Air Assisted Hydraulic (Std.) Disc Front (Std.) Drum Rear 15" x 7" (Std.)	43	43	FUEL TANK: Dual 40 Gallon LH & RH Rectangular Steel
19	19	BRAKE EQUIPMENT: Air Compressor, 9.5 CFM (Std.) Parking Brake, Rear Wheel, Spring-Set w/Dash Mounted Control (Std.)	47	47	SUSPENSION, FRONT: 9,000 lb. (Std.)
22	NA	CAB: Cargo Cab (Std.) Seats, Non-Suspended Individual Drivers and 2-Passenger Bench (Std.) Seat Trim, Black Cloth w/Red Laser Stripes	47	47	SUSPENSION, REAR: 17,500 lb. (Std.)
24	24	CAB EQUIPMENT: Gauges: Ammeter, Oil Pressure, Coolant Temp., Fuel, Air Pressure (Dual), Tachometer and Speedometer (Std.) Warning Lights: Battery, Cab Latch, Water in Fuel, Parking Brake and Hyd. Brake Press. Off (Std.) Warning Lights w/Buzzer: Brake Low Air Pressure, Low Coolant Level, Low Oil Press. and High Coolant Temp. (Std.)	50/51	50/51	TIRES: Front (2) 010R22.5G (14PR) Hwy Rear (4) 010R22.5G (14PR) Hwy
25	25	CAB EQUIPMENT: (Cont'd) Windshield Wipers, Two-Speed Elec. w/Elec. Washers (Std.) Radio, AM Push Button	56	56	TRANSMISSION: Clark CL-455 Soft Fourth, 5-Speed
27	27	ELECTRICAL: Alternator, 75 Amp. (1125 Watt) Battery, Low Maintenance-Three 12 Volt. (535CCA) (63 Amp. Hr.) (Std.)			

CF-7000-705



CA: 159 in.
WB: 189 in.

Front GAWR: 11,000 lb.
Rear GAWR: 18,500 lb.
Total GVWR: 29,500 lb.

CHASSIS WEIGHT
Front: 6,507 lb.
Rear: 3,774 lb.
Total: 10,281 lb.

PERFORMANCE DATA
BODY PAYLOAD
WEIGHT DISTRIBUTION (Water Level Loading)
Front: (19%)
Rear: (81%)
Total: (100%)

DRIVETRAIN PERFORMANCE
Gradeability: 30%
Geared Speed: 62 MPH
Total Reduction: 48:1

FOR 20 FOOT BODY

Chassis-Cab Specifications					
08	94	EXTERIOR COLOR: Diamond White (Std.)	30	CD	ENGINE: Ford Diesel (Std.) (170 HP) @ 2600 RPM
10	AJ	AXLE, FRONT: 12,000 lb. (Std.)	36	36	ENGINE EQUIPMENT: Air Cleaner, Single Stage Dry Type (Std.) Clutch, 14" 1-Plate, Full Type (Std.) Exhaust System, Single Horizontal Muffler and Pipe-LH (Std.) Fuel/Water Separator (Std.) Oil Cooler-Engine Mounted (Std.) Oil Filter-Two, 1-1/2 Qt. Full Flow, Disposable (Std.) Radiator-709 Sq. In. (Std.)
11	3H	AXLE, REAR: Rockwell, RS-21-230 (4.88/6.88) 21,000 lb.	37	37	ENGINE EQUIPMENT: (Cont'd) Fan Clutch Viscous (Std.) Gauge, Air Cleaner Restriction Indicator (Std.) Throttle, Hand Control (Std.)
13	13	AXLE EQUIPMENT: Mag. Top Fill & Drain Plugs (Std.) Power Steering, 20" Soft-Fee, Locking Steering Wheel (Std.) Shock Absorbers, Front (Std.) Stabilizer Bar, Front (Std.) Wheel Seals, Front, Unized (Std.) Wheel Seals, Rear, Two-Piece Wet-Type (Std.)	40	40	FRAME: 10.2 SM-50,000 PSI w/L" Reinforcement (Std.)
16	HE	BRAKES, SERVICE: Full Air Brakes Cam Type Drum Front (15"x4") Drum Rear (16.12"x7")	43	43	FUEL TANK: 40 Gallon RH Rectangular Steel (Std.)
19	19	BRAKE EQUIPMENT: Air Compressor, 9.5 CFM (Std.) Parking Brake, Rear Wheel, Spring-Set w/Dash Mounted Control (Std.)	47	47	SUSPENSION, FRONT: 11,000 lb. (Std.)
22	NA	CAB: Cargo Cab (Std.) Seats, Non-Suspended Individual Drivers and 2-Passenger Bench (Std.) Seat Trim, Black Cloth w/Red Laser Stripes	47	47	SUSPENSION, REAR: 18,500 lb. (Std.)
24	24	CAB EQUIPMENT: Gauges: Ammeter, Oil Pressure, Coolant Temp., Fuel, Air Pressure (Dual), Tachometer and Speedometer (Std.) Warning Lights: Battery, Cab Latch, Water in Fuel, Parking Brake and Hyd. Brake Press. Off (Std.) Warning Lights w/Buzzer: Brake Low Air Pressure, Low Coolant Level, Low Oil Press. and High Coolant Temp. (Std.)	50/51	50/51	TIRES: Front (2) 010R22.5G (14PR) Hwy Rear (4) 010R22.5G (14PR) Hwy
25	25	CAB EQUIPMENT: (Cont'd) Windshield Wipers, Two-Speed Elec. w/Elec. Washers (Std.) Radio, AM Push Button	56	56	TRANSMISSION: Clark CL-455 Soft Fourth, 5-Speed
27	27	ELECTRICAL: Alternator, 60 Amp. (900 Watt) (Std.) Battery, Low Maintenance-Two 12 Volt. (535CCA) (63 Amp. Hr.) (Std.)			

CF-6000-717



CA: 195 in.
WB: 225 in.

Front GAWR: 9,000 lb.
Rear GAWR: 17,500 lb.
Total GVWR: 26,500 lb.

CHASSIS WEIGHT
Front: 6,407 lb.
Rear: 3,574 lb.
Total: 10,081 lb.

PERFORMANCE DATA
BODY PAYLOAD
WEIGHT DISTRIBUTION (Water Level Loading)
Front: (21%)
Rear: (79%)
Total: (100%)

DRIVETRAIN PERFORMANCE
Gradeability: 30%
Geared Speed: 66 MPH
Total Reduction: 44:1

FOR 24 FOOT BODY

Chassis-Cab Specifications					
08	94	EXTERIOR COLOR: Diamond White (Std.)	30	CD	ENGINE: Ford Diesel (Std.) (170 HP) @ 2600 RPM
10	AG	AXLE, FRONT: 9,000 lb. (Std.)	36	36	ENGINE EQUIPMENT: Air Cleaner, Single Stage Dry Type (Std.) Clutch, 14" 1-Plate, Full Type (Std.) Exhaust System, Single Horizontal Muffler and Pipe-LH (Std.) Fuel/Water Separator (Std.) Oil Cooler-Engine Mounted (Std.) Oil Filter-Two, 1-1/2 Qt. Full Flow, Disposable (Std.) Radiator-643 Sq. In. (Std.)
11	W7	AXLE, REAR: Rockwell, RS-17-220 (4.56/6.36) 17,500 lb.	37	37	ENGINE EQUIPMENT: (Cont'd) Fan Clutch Viscous (Std.) Gauge, Air Cleaner Restriction Indicator (Std.) Throttle, Hand Control (Std.)
13	13	AXLE EQUIPMENT: Mag. Top Fill & Drain Plugs (Std.) Power Steering, 20" Soft-Fee, Locking Steering Wheel (Std.) Shock Absorbers, Front (Std.) Stabilizer Bar, Front (Std.) Wheel Seals, Front, Unized (Std.) Wheel Seals, Rear, Two-Piece Wet-Type (Std.)	40	40	FRAME: 10.2 SM-50,000 PSI Single Channel (Std.)
16	HD	BRAKES, SERVICE: Split Power-Air Assisted Hydraulic (Std.) Disc Front (Std.) Drum Rear 15" x 7" (Std.)	43	43	FUEL TANK: 40 Gallon RH Rectangular Steel (Std.)
19	19	BRAKE EQUIPMENT: Air Compressor, 9.5 CFM (Std.) Parking Brake, Rear Wheel, Spring-Set w/Dash Mounted Control (Std.)	47	47	SUSPENSION, FRONT: 9,000 lb. (Std.)
22	NA	CAB: Cargo Cab (Std.) Seats, Non-Suspended Individual Drivers and 2-Passenger Bench (Std.) Seat Trim, Black Cloth w/Red Laser Stripes	47	47	SUSPENSION, REAR: 17,500 lb. (Std.)
24	24	CAB EQUIPMENT: Gauges: Ammeter, Oil Pressure, Coolant Temp., Fuel, Air Pressure (Dual), Tachometer and Speedometer (Std.) Warning Lights: Battery, Cab Latch, Water in Fuel, Parking Brake and Hyd. Brake Press. Off (Std.) Warning Lights w/Buzzer: Brake Low Air Pressure, Low Coolant Level, Low Oil Press. and High Coolant Temp. (Std.)	50/51	50/51	TIRES: Front (2) 010R22.5G (14PR) Hwy Rear (4) 010R22.5G (14PR) Hwy
25	25	CAB EQUIPMENT: (Cont'd) Windshield Wipers, Two-Speed Elec. w/Elec. Washers (Std.) Radio, AM Push Button	56	56	TRANSMISSION: Clark CL-455 Soft Fourth, 5-Speed
27	27	ELECTRICAL: Alternator, 60 Amp. (900 Watt) (Std.) Battery, Low Maintenance-Two 12 Volt. (535CCA) (63 Amp. Hr.) (Std.)			

CF-8000-734



CA: 177 in.
WB: 207 in.

Front GAWR: 12,000 lb.
Rear GAWR: 21,000 lb.
Total GVWR: 33,000 lb.

CHASSIS WEIGHT
Front: 6,557 lb.
Rear: 3,924 lb.
Total: 10,481 lb.

PERFORMANCE DATA
BODY PAYLOAD
WEIGHT DISTRIBUTION (Water Level Loading)
Front: (20%)
Rear: (80%)
Total: (100%)

DRIVETRAIN PERFORMANCE
Gradeability: 30%
Geared Speed: 62 MPH
Total Reduction: 43:1

FOR 22 FOOT BODY

Chassis-Cab Specifications					
08	94	EXTERIOR COLOR: Diamond White (Std.)	30	AA	ENGINE: Ford Diesel (185 HP) @ 2600 RPM
10	AJ	AXLE, FRONT: 12,000 lb. (Std.)	36	36	ENGINE EQUIPMENT: Air Cleaner, Single Stage Dry Type (Std.) Clutch, 14" 1-Plate, Full Type (Std.) Exhaust System, Single Horizontal Muffler and Pipe-LH (Std.) Fuel/Water Separator (Std.) Oil Cooler-Engine Mounted (Std.) Oil Filter-Two, 1-1/2 Qt. Full Flow, Disposable (Std.) Radiator-709 Sq. In. (Std.)
11	3H	AXLE, REAR: Rockwell, RS-21-230 (4.88/6.88) 21,000 lb.	37	37	ENGINE EQUIPMENT: (Cont'd) Fan Clutch Viscous (Std.) Gauge, Air Cleaner Restriction Indicator (Std.) Throttle, Hand Control (Std.)
13	13	AXLE EQUIPMENT: Mag. Top Fill & Drain Plugs (Std.) Power Steering, 20" Soft-Fee, Locking Steering Wheel (Std.) Shock Absorbers, Front (Std.) Stabilizer Bar, Front (Std.) Wheel Seals, Front, Unized (Std.) Wheel Seals, Rear, Two-Piece Wet-Type (Std.)	40	40	FRAME: 10.2 SM-50,000 PSI (Std.)
16	HD	BRAKES, SERVICE: Split Power-Air Assisted Hydraulic (Std.) Disc Front (Std.) Drum Rear 15" x 7" (Std.)	43	43	FUEL TANK: 40 Gallon RH Rectangular Steel (Std.)
19	19	BRAKE EQUIPMENT: Air Compressor, 9.5 CFM (Std.) Parking Brake, Rear Wheel, Spring-Set w/Dash Mounted Control (Std.)	47	47	SUSPENSION, FRONT: 12,000 lb. (Std.)
22	NA	CAB: Cargo Cab (Std.) Seats, Non-Suspended Individual Drivers and 2-Passenger Bench (Std.) Seat Trim, Black Cloth w/Red Laser Stripes	47	47	SUSPENSION, REAR: 22,000 lb.
24	24	CAB EQUIPMENT: Gauges: Ammeter, Oil Pressure, Coolant Temp., Fuel, Air Pressure (Dual), Tachometer and Speedometer (Std.) Warning Lights: Battery, Cab Latch, Water in Fuel, Parking Brake and Hyd. Brake Press. Off (Std.) Warning Lights w/Buzzer: Brake Low Air Pressure, Low Coolant Level, Low Oil Press. and High Coolant Temp. (Std.)	50/51	50/51	TIRES: Front (2) 011R22.5G (14PR) Hwy Rear (4) 011R22.5G (14PR) Hwy
25	25	CAB EQUIPMENT: (Cont'd) Windshield Wipers, Two-Speed Elec. w/Elec. Washers (Std.) Radio, AM Push Button	56	56	TRANSMISSION: Clark CL-558 Soft Fourth, 5-Speed
27	27	ELECTRICAL: Alternator, 60 Amp. (900 Watt) (Std.) Battery, Low Maintenance-Two 12 Volt. (535CCA) (63 Amp. Hr.) (Std.)			

CF-7000-702



CA: 159 in.
WB: 189 in.

Front GAWR: 11,000 lb.
Rear GAWR: 18,500 lb.
Total GVWR: 29,500 lb.

CHASSIS WEIGHT
Front: 6,709 lb.
Rear: 3,700 lb.
Total: 10,409 lb.

PERFORMANCE DATA
BODY PAYLOAD
WEIGHT DISTRIBUTION (Water Level Loading)
Front: (19%)
Rear: (81%)
Total: (100%)

DRIVETRAIN PERFORMANCE
Gradeability: 25%
Geared Speed: 62 MPH
Total Reduction: 30:1

FOR 20 FOOT BODY

Chassis-Cab Specifications					
08	94	EXTERIOR COLOR: Diamond White (Std.)	30	CD	ENGINE: Ford Diesel (Std.) (170 HP) @ 2600 RPM
10	AJ	AXLE, FRONT: 12,000 lb. (Std.)	36	36	ENGINE EQUIPMENT: Air Cleaner, Single Stage Dry Type (Std.) Clutch, 14" 1-Plate, Full Type (Std.) Exhaust System, Single Horizontal Muffler and Pipe-LH (Std.) Fuel/Water Separator (Std.) Oil Cooler-Engine Mounted (Std.) Oil Filter-Two, 1-1/2 Qt. Full Flow, Disposable (Std.) Radiator-643 Sq. In. w/Bottom Tank Trans. Oil Cooler (Std.)
11	3H	AXLE, REAR: Rockwell, RS-21-145 (4.88) 21,000 lb.	37	37	ENGINE EQUIPMENT: (Cont'd) Fan Clutch Viscous (Std.) Gauge, Air Cleaner Restriction Indicator (Std.) Throttle, Hand Control (Std.)
13	13	AXLE EQUIPMENT: Mag. Top Fill & Drain Plugs (Std.) Power Steering, 20" Soft-Fee, Locking Steering Wheel (Std.) Shock Absorbers, Front (Std.) Stabilizer Bar, Front (Std.) Wheel Seals, Front, Unized (Std.) Wheel Seals, Rear, Two-Piece Wet-Type (Std.)	40	40	FRAME: 10.2 SM-50,000 PSI w/L" Reinforcement (Std.)
16	HD	BRAKES, SERVICE: Split Power-Air Assisted Hydraulic (Std.) Disc Front (Std.) Drum Rear 15" x 7" (Std.)	43	43	FUEL TANK: Dual 40 Gallon LH & RH Rectangular Steel
19	19	BRAKE EQUIPMENT: Air Compressor, 9.5 CFM (Std.) Parking Brake, Rear Wheel, Spring-Set w/Dash Mounted Control (Std.)	47	47	SUSPENSION, FRONT: 11,000 lb. (Std.)
22	NA	CAB: Cargo Cab (Std.) Seats, Non-Suspended Individual Drivers and 2-Passenger Bench (Std.) Seat Trim, Black Cloth w/Red Laser Stripes	47	47	SUSPENSION, REAR: 18,500 lb. (Std.)
24	24	CAB EQUIPMENT: Gauges: Ammeter, Oil Pressure, Coolant Temp., Fuel, Air Pressure (Dual), Tachometer and Speedometer (Std.) Warning Lights: Battery, Cab Latch, Water in Fuel, Parking Brake and Hyd. Brake Press. Off (Std.) Warning Lights w/Buzzer: Brake Low Air Pressure, Low Coolant Level, Low Oil Press. and High Coolant Temp. (Std.)	50/51	50/51	TIRES: Front (2) 010R22.5G (14PR) Hwy Rear (4) 010R22.5G (14PR) Hwy
25	25	CAB EQUIPMENT: (Cont'd) Windshield Wipers, Two-Speed Elec. w/Elec. Washers (Std.) Radio, AM Push Button	56	56	TRANSMISSION: Allison AT-545 4-Speed Automatic
27	27	ELECTRICAL: Alternator, 75 Amp. (1125 Watt) Battery, Low Maintenance-Three 12 Volt. (535CCA) (63 Amp. Hr.) (Std.)			

CF-8000-740



CA: 141 in.
WB: 171 in.

Front GAWR: 12,000 lb.
Rear GAWR: 21,000 lb.
Total GVWR: 33,000 lb.

CHASSIS WEIGHT
Front: 6,557 lb.
Rear: 3,550 lb.
Total: 10,207 lb.

PERFORMANCE DATA
BODY PAYLOAD
WEIGHT DISTRIBUTION (Water Level Loading)
Front: (19%)
Rear: (81%)
Total: (100%)

DRIVETRAIN PERFORMANCE
Gradeability: 25%
Geared Speed: 62 MPH
Total Reduction: 37:1

FOR 18 FOOT BODY

Chassis-Cab Specifications					
08	94	EXTERIOR COLOR: Diamond White (Std.)	30	AB	ENGINE: Ford Diesel (210 HP) @ 2600 RPM
10	AJ	AXLE, FRONT: 12,000 lb. (Std.)	36	36	ENGINE EQUIPMENT: Air Cleaner, Single Stage Dry Type (Std.) Clutch, 14" 1-Plate, Full Type (Std.) Exhaust System, Single Horizontal Muffler and Pipe-LH (Std.) Fuel/Water Separator (Std.) Oil Cooler-Engine Mounted (Std.) Oil Filter-Two, 1-1/2 Qt. Full Flow, Disposable (Std.) Radiator-709 Sq. In. (Std.)
11	3H	AXLE, REAR: Rockwell, RS-21-145 (4.88) 21,000 lb.	37	37	ENGINE EQUIPMENT: (Cont'd) Fan Clutch Viscous (Std.) Gauge, Air Cleaner Restriction Indicator (Std.) Throttle, Hand Control (Std.)
13	13	AXLE EQUIPMENT: Mag. Top Fill & Drain Plugs (Std.) Power Steering, 20" Soft-Fee, Locking Steering Wheel (Std.) Shock Absorbers, Front (Std.) Stabilizer Bar, Front (Std.) Wheel Seals, Front, Unized (Std.) Wheel Seals, Rear, Two-Piece Wet-Type (Std.)	40	40	FRAME: 10.2 SM-50,000 PSI (Std.)
16	HD	BRAKES, SERVICE: Split Power-Air Assisted Hydraulic (Std.) Disc Front (Std.) Drum Rear 15" x 7" (Std.)	43	43	FUEL TANK: 40 Gallon RH Rectangular Steel
19	19	BRAKE EQUIPMENT: Air Compressor, 9.5 CFM (Std.) Parking Brake, Rear Wheel, Spring-Set w/Dash Mounted Control (Std.)	47	47	SUSPENSION, FRONT: 12,000 lb. (Std.)
22	NA	CAB: Cargo Cab (Std.) Seats, Non-Suspended Individual Drivers and 2-Passenger Bench (Std.) Seat Trim, Vinyl (Std.)	47	47	SUSPENSION, REAR: 22,000 lb.
24	24	CAB EQUIPMENT: Gauges: Ammeter, Oil Pressure, Coolant Temp., Fuel, Air Pressure (Dual), Tachometer and Speedometer (Std.) Warning Lights: Battery, Cab Latch, Water in Fuel, Parking Brake and Hyd. Brake Press. Off (Std.) Warning Lights w/Buzzer: Brake Low Air Pressure, Low Coolant Level, Low Oil Press. and High Coolant Temp. (Std.)	50/51	50/51	TIRES: Front (2) 011R22.5G (14PR) Hwy Rear (4) 011R22.5G (14PR) Hwy
25	25	CAB EQUIPMENT: (Cont'd) Windshield Wipers, Two-Speed Elec. w/Elec. Washers (Std.) Radio, AM Push Button	56	56	TRANSMISSION: Clark CL-551 Wide Ratio 5-Speed
27	27	ELECTRICAL: Alternator, 60 Amp. (900 Watt) (Std.) Battery, Low Maintenance-Two 12 Volt. (535CCA) (63 Amp. Hr.) (Std.)			

SELECTED WORK-READY SPEC SHEETS

SELECTED WORK-READY SPEC SHEETS

CF-8000-747



CA: 195 in.
WB: 225 in.

Front GAWR: 12,000 lb.
Rear GAWR: 21,000 lb.
Total GVWR: 33,000 lb.

CHASSIS WEIGHT
Front: 5,707 lb.
Rear: 4,074 lb.
Total: 10,581 lb.

PERFORMANCE DATA
BODY PAYLOAD
WEIGHT DISTRIBUTION
(Water Level Loading)
Front: (21%)
Rear: (79%)
Total: (100%)

DRIVETRAIN PERFORMANCE
Gradeability: 32%
Gained Speed: 65 MPH
Total Reduction: 42:1

FOR
24 FOOT
BODY

Chassis-Cab Specifications

08 94	EXTERIOR COLOR: Diamond White (Std.)	30 AB	ENGINE: Ford Diesel (Std.) (210 HP) @ 2600 RPM
10 AJ	AXLE, FRONT: 13,000 lb. (Std.)	36	ENGINE EQUIPMENT: Air Cleaner, Single Stage Dry Type (Std.) Clutch, 14" 1-Plate, Pull Type (Std.) Exhaust System, Single Horizontal Muffler and Pipe-LH (Std.) Fuel/Water Separator (Std.) Oil Cooler—Engine Mounted (Std.) Oil Filter—Two, 1-1/2 Qt. Full Flow, Disposable (Std.) Radiator—709 Sq. in. (Std.)
11 ZH	AXLE, REAR: Rockerel, HS-21-290 (4.88/6.80) 23,000 lb.	37	ENGINE EQUIPMENT: (Cont'd) Fan Clutch Viscous (Std.) Gauge, Air Cleaner Restriction Indicator (Std.) Throttle, Hand Control (Std.)
13	AXLE EQUIPMENT: Mag. Trap Fil & Drain Plugs (Std.) Power Steering, 20" Soft Foot, Locking Steering Wheel (Std.) Shock Absorbers, Front (Std.) Stabilizer Bar, Front (Std.) Wheel Seals, Front, Unteized (Std.) Wheel Seals, Rear, Two-Piece Wet-Type (Std.)	40 BN	FRAME: 15.0 5M—50,000 PSI (Inc.)
16 HE	BRAKES, SERVICE: Full Air Brakes Cam Type Drum Front 15" x 4" Drum Rear 16 1/2" x 7"	43 EB	FUEL TANK: Dual 40 Gallon LH & RH Rectangular Steel
19	BRAKE EQUIPMENT: Air Compressor 9.5 CFM (Std.) Parking Brake, Rear Wheel, Spring-Set w/ Dash Mounted Control (Std.)	47 CC	SUSPENSION, FRONT: 12,000 lb. (Inc.)
22 NA MA	CAB: Cargo Cab (Std.) Seats, Mechanical Suspension Driver's and 2-Passenger Bench (Std.) Seat Trim, Black Vinyl (Std.)	47 DE	SUSPENSION, REAR: 22,000 lb.
24	CAB EQUIPMENT: Gauges, Ammeter, Oil Pressure, Coolant Temp., Fuel, Air Pressure (Dual), Tachometer and Speedometer (Std.) Warning Lights, Battery, Cab Latch, Water in Fuel, Parking Brake and Hyd. Brake Press. Dfl. (Std.) Warning Lights w/ Buzzer, Brake Low Air Pressure, Low Coolant Level, Low Oil Press. and High Coolant Temp. (Std.)	50/51	TIRES: Front (2) 011R22.5G (16PR) Hwy Rear (4) 22.5x7.5 10-Hole Steel Disc
25	CAB EQUIPMENT: (Cont'd) Windshield Wipers, Two-Speed Elec. w/ Elec. Washers (Std.) Radio, AM Push Button	56 CH	TRANSMISSION: Clark CL-558 Soft Fourth, 5-Speed
27 TL LA	ELECTRICAL: Alternator 90 Amp (1365 Volt) Battery, Low Maintenance—Three 12 Volt, (S35CCA) (63 Amp. Hr.)		

Chassis-Cab Specifications

08 94	EXTERIOR COLOR: Diamond White (Std.)	30 AB	ENGINE: Ford Diesel (Std.) (210 HP) @ 2600 RPM
10 AX	AXLE, FRONT: 13,000 lb. (Std.)	36	ENGINE EQUIPMENT: Air Cleaner, Single Stage Dry Type (Std.) Clutch, 14" 1-Plate, Pull Type (Std.) Exhaust System, Single Horizontal Muffler and Pipe-LH (Std.) Fuel/Water Separator (Std.) Oil Cooler—Engine Mounted (Std.) Oil Filter—Two, 1-1/2 Qt. Full Flow, Disposable (Std.) Radiator—709 Sq. in. (Std.)
11 X4	AXLE, REAR: Rockerel, HS-23-240 (4.88/6.65) 23,000 lb.	37	ENGINE EQUIPMENT: (Cont'd) Fan Clutch Viscous (Std.) Gauge, Air Cleaner Restriction Indicator (Std.) Throttle, Hand Control (Std.) Exhaust Brake, Automatic
13	AXLE EQUIPMENT: Mag. Trap Fil & Drain Plugs (Std.) Power Steering, 20" Soft Foot, Locking Steering Wheel (Std.) Shock Absorbers, Front (Std.) Stabilizer Bar, Front (Std.) Wheel Seals, Front, Unteized (Std.) Wheel Seals, Rear, Two-Piece Wet-Type (Std.) Rear Stabilizer Bar and Shock Absorber Package	40 BP	FRAME: 20.0 5M—50,000 PSI w/ "L" Reinforcement (Std.)
16 HE	BRAKES, SERVICE: Full Air Brakes Cam Type (Std.) Drum Front 15" x 4" (Std.) Drum Rear 16 1/2" x 7" (Std.)	43 EB	FUEL TANK: 40 Gallon RH Rectangular Steel (Std.)
19	BRAKE EQUIPMENT: Air Compressor 9.5 CFM (Std.) Parking Brake, Rear Wheel, Spring-Set w/ Dash Mounted Control (Std.)	47 CD	SUSPENSION, FRONT: 13,000 lb. (Std.)
22 NA MG	CAB: Cargo Cab (Std.) Seats, Non-Suspended Individual Driver's and 2-Passenger Bench (Std.) Seat Trim, Black Vinyl (Std.)	47 DD	SUSPENSION, REAR: 23,000 lb. (Std.)
24	CAB EQUIPMENT: Gauges, Ammeter, Oil Pressure, Coolant Temp., Fuel, Air Pressure (Dual), Tachometer and Speedometer (Std.) Warning Lights, Battery, Cab Latch, Water in Fuel, Parking Brake and Hyd. Brake Press. Dfl. (Std.) Warning Lights w/ Buzzer, Brake Low Air Pressure, Low Coolant Level, Low Oil Press. and High Coolant Temp. (Std.)	50/51	TIRES: Front (2) 011R22.5H (16PR) Hwy Rear (4) 011R22.5H (16PR) Hwy
25	CAB EQUIPMENT: (Cont'd) Windshield Wipers, Two-Speed Elec. w/ Elec. Washers (Std.) Radio, AM Push Button	56 CH	TRANSMISSION: Clark CL-558 Soft Fourth, 5-Speed
27 TL LA	ELECTRICAL: Alternator 75 Amp (1125 Volt) Battery, Low Maintenance—Three 12 Volt, (S35CCA) (63 Amp. Hr.)		

Chassis-Cab Specifications

08 94	EXTERIOR COLOR: Diamond White (Std.)	30 AB	ENGINE: Ford Diesel (Std.) (210 HP) @ 2600 RPM
10 AX	AXLE, FRONT: 13,000 lb. (Std.)	36	ENGINE EQUIPMENT: Air Cleaner, Single Stage Dry Type (Std.) Clutch, 14" 1-Plate, Pull Type (Std.) Exhaust System, Single Horizontal Muffler and Pipe-LH (Std.) Fuel/Water Separator (Std.) Oil Cooler—Engine Mounted (Std.) Oil Filter—Two, 1-1/2 Qt. Full Flow, Disposable (Std.) Radiator—709 Sq. in. (Std.)
11 X4	AXLE, REAR: Rockerel, HS-23-240 (4.88/6.65) 23,000 lb.	37	ENGINE EQUIPMENT: (Cont'd) Fan Clutch Viscous (Std.) Gauge, Air Cleaner Restriction Indicator (Std.) Throttle, Hand Control (Std.) Exhaust Brake, Automatic
13	AXLE EQUIPMENT: Mag. Trap Fil & Drain Plugs (Std.) Power Steering, 20" Soft Foot, Locking Steering Wheel (Std.) Shock Absorbers, Front (Std.) Stabilizer Bar, Front (Std.) Wheel Seals, Front, Unteized (Std.) Wheel Seals, Rear, Two-Piece Wet-Type (Std.) Rear Stabilizer Bar and Shock Absorber Package	40 BP	FRAME: 20.0 5M—50,000 PSI w/ "L" Reinforcement (Std.)
16 HE	BRAKES, SERVICE: Full Air Brakes Cam Type (Std.) Drum Front 15" x 4" (Std.) Drum Rear 16 1/2" x 7" (Std.)	43 EB	FUEL TANK: Dual 40 Gallon LH & RH Rectangular Steel
19	BRAKE EQUIPMENT: Air Compressor 9.5 CFM (Std.) Parking Brake, Rear Wheel, Spring-Set w/ Dash Mounted Control (Std.)	47 CD	SUSPENSION, FRONT: 13,000 lb. (Std.)
22 NA MA	CAB: Cargo Cab (Std.) Seats, Mechanical Suspension Driver's and 2-Passenger Bench (Std.) Seat Trim, Black Cloth w/ Red Laser Stripes	47 DD	SUSPENSION, REAR: 23,000 lb. (Std.)
24	CAB EQUIPMENT: Gauges, Ammeter, Oil Pressure, Coolant Temp., Fuel, Air Pressure (Dual), Tachometer and Speedometer (Std.) Warning Lights, Battery, Cab Latch, Water in Fuel, Parking Brake and Hyd. Brake Press. Dfl. (Std.) Warning Lights w/ Buzzer, Brake Low Air Pressure, Low Coolant Level, Low Oil Press. and High Coolant Temp. (Std.)	50/51	TIRES: Front (2) 011R22.5H (16PR) Hwy Rear (4) 011R22.5H (16PR) Hwy
25	CAB EQUIPMENT: (Cont'd) Windshield Wipers, Two-Speed Elec. w/ Elec. Washers (Std.) Radio, AM Push Button	56 CH	TRANSMISSION: Clark CL-558 Soft Fourth, 5-Speed
27 TL LA	ELECTRICAL: Alternator 75 Amp (1125 Volt) Battery, Low Maintenance—Three 12 Volt, (S35CCA) (63 Amp. Hr.)		

CF-8000-704



CA: 177 in.
WB: 207 in.

Front GAWR: 13,000 lb.
Rear GAWR: 23,000 lb.
Total GVWR: 36,000 lb.

CHASSIS WEIGHT
Front: TBD lb.
Rear: TBD lb.
Total: TBD lb.

PERFORMANCE DATA
BODY PAYLOAD
WEIGHT DISTRIBUTION
(Water Level Loading)
Front: (50%)
Rear: (50%)
Total: (100%)

DRIVETRAIN PERFORMANCE
Gradeability: 26%
Gained Speed: 64 MPH
Total Reduction: 42:1

FOR
22 FOOT
BODY

CARGO

1987 "WORK-READY"—49 STATE VEHICLES SPECIFICATION SUMMARY

1987 "WORK-READY" Code	WB/CA	GVW-GCW (000)	Engine	F/A (000)	R/A (000)	Trans.	Tires	Wheels	Brake Type	Vocation
CF-6000-701	153/123	26.5	Ford Dsl. (170 HP)	9	17.5	CL-450	010R x 22.5(14)	22.5 x 7.5(D)	H	CV
CF-6000-702	171/141	26.5	Ford Dsl. (170 HP)	9	17.5	AT-545	010R x 22.5(14)	22.5 x 7.5(D)	H	CV
CF-6000-703	171/141	26.5	Ford Dsl. (170 HP)	9	17.5(2)	CL-455	010R x 22.5(14)	22.5 x 7.5(D)	H	CV
CF-6000-704	171/141	26.5	Ford Dsl. (170 HP)	9	17.5(2)	CL-455	010R x 22.5(14)	22.5 x 7.5(D)	H	CV
CF-6000-705	189/159	26.5	Ford Dsl. (170 HP)	9	17.5	AT-545	010R x 22.5(14)	22.5 x 7.5(D)	H	CV
CF-6000-706	189/159	26.5	Ford Dsl. (170 HP)	9	17.5	CL-450	010R x 22.5(14)	22.5 x 7.5(D)	H	CV
CF-6000-707	189/159	26.5	Ford Dsl. (170 HP)	9	17.5(2)	CL-455	010R x 22.5(14)	22.5 x 7.5(D)	H	CV
CF-6000-708	189/159	26.5	Ford Dsl. (170 HP)	9	17.5	CL-450	010R x 22.5(14)	22.5 x 7.5(D)	H	CV
CF-6000-709	189/159	26.5	Ford Dsl. (170 HP)	9	17.5(2)	CL-455	010R x 22.5(14)	22.5 x 7.5(D)	H	CV
CF-6000-710	207/177	26.5	Ford Dsl. (170 HP)	9	17.5	AT-545	010R x 22.5(14)	22.5 x 7.5(D)	H	CV
CF-6000-711	207/177	26.5	Ford Dsl. (170 HP)	9	17.5	CL-450	010R x 22.5(14)	22.5 x 7.5(D)	H	CV
CF-6000-712	207/177	26.5	Ford Dsl. (170 HP)	9	17.5(2)	CL-455	010R x 22.5(14)	22.5 x 7.5(D)	H	CV
CF-6000-713	207/177	26.5	Ford Dsl. (170 HP)	9	17.5	CL-450	010R x 22.5(14)	22.5 x 7.5(D)	H	CV
CF-6000-714	207/177	26.5	Ford Dsl. (170 HP)	9	17.5(2)	CL-455	010R x 22.5(14)	22.5 x 7.5(D)	H	CV
CF-6000-715	225/195	26.5	Ford Dsl. (170 HP)	9	17.5	AT-545	010R x 22.5(14)	22.5 x 7.5(D)	H	CV
CF-6000-716	225/195	26.5	Ford Dsl. (170 HP)	9	17.5	CL-450	010R x 22.5(14)	22.5 x 7.5(D)	H	CV
CF-6000-717	225/195	26.5	Ford Dsl. (170 HP)	9	17.5(2)	CL-455	010R x 22.5(14)	22.5 x 7.5(D)	H	CV
CF-6000-718	225/195	26.5	Ford Dsl. (170 HP)	9	17.5	CL-450	010R x 22.5(14)	22.5 x 7.5(D)	H	CV
CF-6000-719	225/195	26.5	Ford Dsl. (170 HP)	9	17.5(2)	CL-455	010R x 22.5(14)	22.5 x 7.5(D)	H	CV
CF-7000-723	171/141	29.5	Ford Dsl. (170 HP)	12	21(2)	AT-545	010R x 22.5(14)	22.5 x 7.5(D)	H	CV
CF-7000-701	171/141	29.5	Ford Dsl. (170 HP)	12	21(2)	CL-455	010R x 22.5(14)	22.5 x 7.5(D)	H	CV
CF-7000-702	189/159	29.5	Ford Dsl. (170 HP)	12	21	AT-545	010R x 22.5(14)	22.5 x 7.5(D)	H	CV
CF-7000-703	189/159	29.5	Ford Dsl. (170 HP)	12	21	CL-450	010R x 22.5(14)	22.5 x 7.5(D)	H	CV
CF-7000-704	189/159	29.5	Ford Dsl. (170 HP)	12	21(2)	CL-455	010R x 22.5(14)	22.5 x 7.5(D)	H	CV
CF-7000-705	189/159	29.5	Ford Dsl. (170 HP)	12	21(2)	CL-455	010R x 22.5(14)	22.5 x 7.5(D)	A	CV
CF-7000-706	189/159	29.5	Ford Dsl. (170 HP)	12	21(2)	CL-455	010R x 22.5(14)	22.5 x 7.5(D)	H	CV
CF-7000-707	189/159	29.5	Ford Dsl. (170 HP)	12	21(2)	CL-455	010R x 22.5(14)	22.5 x 7.5(D)	A	CV
CF-7000-708	189/159	29.5	Ford Dsl. (170 HP)	12	21(2)	CL-455	010R x 22.5(14)	22.5 x 7.5(D)	A	CV
CF-7000-709	207/177	29.5	Ford Dsl. (170 HP)	12	21	AT-545	010R x 22.5(14)	22.5 x 7.5(D)	H	CV
CF-7000-710	207/177	29.5	Ford Dsl. (170 HP)	12	21	CL-450	010R x 22.5(14)	22.5 x 7.5(D)	H	CV
CF-7000-711	207/177	29.5	Ford Dsl. (170 HP)	12	21(2)	CL-455	010R x 22.5(14)	22.5 x 7.5(D)	H	CV
CF-7000-712	207/177	29.5	Ford Dsl. (170 HP)	12	21(2)	CL-455	010R x 22.5(14)	22.5 x 7.5(D)	A	CV

(2) — Indicates two-speed rear axle; (D) — Disc wheel; (H) — Hydraulic Brakes; (A) — Air Brakes; (CV) — Cargo Van.

CARGO

1987 "WORK-READY" - 49 STATE VEHICLES SPECIFICATION SUMMARY

1987 "WORK-READY" Code	WB/CA	GVW-GCW (000)	Engine	F/A (000)	R/A (000)	Trans.	Tires	Wheels	Brake Type	Vocation
CF-7000-713	207/177	29.5	Ford Dsl. (170 HP)	12	21(2)	CL-455	010R x 22.5(14)	22.5 x 7.5(D)	H	CV
CF-7000-714	207/177	29.5	Ford Dsl. (170 HP)	12	21(2)	CL-455	010R x 22.5(14)	22.5 x 7.5(D)	A	CV
CF-7000-715	207/177	29.5	Ford Dsl. (170 HP)	12	21(2)	CL-455	010R x 22.5(14)	22.5 x 7.5(D)	A	CV
CF-7000-716	225/195	29.5	Ford Dsl. (170 HP)	12	21	AT-545	010R x 22.5(14)	22.5 x 7.5(D)	A	CV
CF-7000-717	225/195	29.5	Ford Dsl. (170 HP)	12	21	CL-450	010R x 22.5(14)	22.5 x 7.5(D)	H	CV
CF-7000-718	225/195	29.5	Ford Dsl. (170 HP)	12	21(2)	CL-455	010R x 22.5(14)	22.5 x 7.5(D)	H	CV
CF-7000-719	225/195	29.5	Ford Dsl. (170 HP)	12	21(2)	CL-455	010R x 22.5(14)	22.5 x 7.5(D)	A	CV
CF-7000-720	225/195	29.5	Ford Dsl. (170 HP)	12	21(2)	CL-455	010R x 22.5(14)	22.5 x 7.5(D)	H	CV
CF-7000-721	225/195	29.5	Ford Dsl. (170 HP)	12	21(2)	CL-455	010R x 22.5(14)	22.5 x 7.5(D)	A	CV
CF-7000-722	225/195	29.5	Ford Dsl. (170 HP)	12	21(2)	CL-455	010R x 22.5(14)	22.5 x 7.5(D)	A	CV
CF-8000-702	171/141	36	Ford Dsl. (210 HP)	13	23(2)	CL-558	011R x 22.5(16)	22.5 x 8.25(D)	A	CV
CF-8000-703	189/159	36	Ford Dsl. (210 HP)	13	23(2)	CL-558	011R x 22.5(16)	22.5 x 8.25(D)	A	CV
CF-8000-704	207/177	36	Ford Dsl. (210 HP)	13	23(2)	CL-558	011R x 22.5(16)	22.5 x 8.25(D)	A	CV
CF-8000-705	225/195	36	Ford Dsl. (210 HP)	13	23(2)	CL-558	011R x 22.5(16)	22.5 x 8.25(D)	A	CV
CF-8000-730	171/141	33	Ford Dsl. (185 HP)	12	21	CL-551	011R x 22.5(14)	22.5 x 7.5(D)	H	CV
CF-8000-731	171/141	33	Ford Dsl. (185 HP)	12	21(2)	CL-558	011R x 22.5(14)	22.5 x 7.5(D)	A	CV
CF-8000-732	189/159	33	Ford Dsl. (185 HP)	12	21	CL-551	011R x 22.5(14)	22.5 x 7.5(D)	A	CV
CF-8000-733	189/159	33	Ford Dsl. (185 HP)	12	21(2)	CL-558	011R x 22.5(14)	22.5 x 7.5(D)	A	CV
CF-8000-734	207/177	33	Ford Dsl. (185 HP)	12	21(2)	CL-558	011R x 22.5(14)	22.5 x 7.5(D)	H	CV
CF-8000-735	207/177	33	Ford Dsl. (185 HP)	12	21(2)	CL-558	011R x 22.5(14)	22.5 x 7.5(D)	A	CV
CF-8000-736	207/177	33	Ford Dsl. (185 HP)	12	21(2)	CL-558	011R x 22.5(14)	22.5 x 7.5(D)	A	CV
CF-8000-737	225/195	33	Ford Dsl. (185 HP)	12	21(2)	CL-558	011R x 22.5(14)	22.5 x 7.5(D)	A	CV
CF-8000-738	225/195	33	Ford Dsl. (185 HP)	12	21(2)	CL-558	011R x 22.5(14)	22.5 x 7.5(D)	H	CV
CF-8000-740	171/141	33	Ford Dsl. (210 HP)	12	21	CL-551	011R x 22.5(14)	22.5 x 7.5(D)	H	CV
CF-8000-741	171/141	33	Ford Dsl. (210 HP)	12	21(2)	CL-558	011R x 22.5(14)	22.5 x 7.5(D)	A	CV
CF-8000-742	189/159	33	Ford Dsl. (210 HP)	12	21	CL-551	011R x 22.5(14)	22.5 x 7.5(D)	A	CV
CF-8000-743	189/159	33	Ford Dsl. (210 HP)	12	21(2)	CL-558	011R x 22.5(14)	22.5 x 7.5(D)	A	CV
CF-8000-744	207/177	33	Ford Dsl. (210 HP)	12	21(2)	CL-558	011R x 22.5(14)	22.5 x 7.5(D)	H	CV
CF-8000-745	207/177	33	Ford Dsl. (210 HP)	12	21(2)	CL-558	011R x 22.5(14)	22.5 x 7.5(D)	A	CV
CF-8000-746	225/195	33	Ford Dsl. (210 HP)	12	21(2)	CL-558	011R x 22.5(14)	22.5 x 7.5(D)	A	CV
CF-8000-747	225/195	33	Ford Dsl. (210 HP)	12	21(2)	CL-558	011R x 22.5(14)	22.5 x 7.5(D)	A	CV
CF-8000-748	225/195	33	Ford Dsl. (210 HP)	12	21(2)	CL-558	011R x 22.5(14)	22.5 x 7.5(D)	H	CV

(2) - Indicates two-speed rear axle; (D) - Disc wheel; (CS) - Cast spoke wheel; (H) - Hydraulic Brakes; (A) - Air Brakes; (CV) - Cargo Van.

CARGO

1987 "WORK-READY" - CALIFORNIA VEHICLES SPECIFICATION SUMMARY

1987 "WORK-READY" Code	WB/CA	GVW-GCW (000)	Engine	F/A (000)	R/A (000)	Trans.	Tires	Wheels	Brake Type	Vocation
CF-6000-781	153/123	26.5	Ford Dsl. (170 HP)	9	17.5	CL-450	010R x 22.5(14)	22.5 x 7.5(D)	H	CV
CF-6000-782	171/141	26.5	Ford Dsl. (170 HP)	9	17.5	AT-545	010R x 22.5(14)	22.5 x 7.5(D)	H	CV
CF-6000-783	171/141	26.5	Ford Dsl. (170 HP)	9	17.5(2)	CL-455	010R x 22.5(14)	22.5 x 7.5(D)	H	CV
CF-6000-784	171/141	26.5	Ford Dsl. (170 HP)	9	17.5(2)	CL-455	010R x 22.5(14)	22.5 x 7.5(D)	H	CV
CF-6000-785	189/159	26.5	Ford Dsl. (170 HP)	9	17.5	AT-545	010R x 22.5(14)	22.5 x 7.5(D)	H	CV
CF-6000-786	189/159	26.5	Ford Dsl. (170 HP)	9	17.5	CL-450	010R x 22.5(14)	22.5 x 7.5(D)	H	CV
CF-6000-787	189/159	26.5	Ford Dsl. (170 HP)	9	17.5(2)	CL-455	010R x 22.5(14)	22.5 x 7.5(D)	H	CV
CF-6000-788	189/159	26.5	Ford Dsl. (170 HP)	9	17.5	CL-450	010R x 22.5(14)	22.5 x 7.5(D)	H	CV
CF-6000-789	189/159	26.5	Ford Dsl. (170 HP)	9	17.5(2)	CL-455	010R x 22.5(14)	22.5 x 7.5(D)	H	CV
CF-6000-790	207/177	26.5	Ford Dsl. (170 HP)	9	17.5	AT-545	010R x 22.5(14)	22.5 x 7.5(D)	H	CV
CF-6000-791	207/177	26.5	Ford Dsl. (170 HP)	9	17.5	CL-450	010R x 22.5(14)	22.5 x 7.5(D)	H	CV
CF-6000-792	207/177	26.5	Ford Dsl. (170 HP)	9	17.5(2)	CL-455	010R x 22.5(14)	22.5 x 7.5(D)	H	CV
CF-6000-793	207/177	26.5	Ford Dsl. (170 HP)	9	17.5	CL-450	010R x 22.5(14)	22.5 x 7.5(D)	H	CV
CF-6000-794	207/177	26.5	Ford Dsl. (170 HP)	9	17.5(2)	CL-455	010R x 22.5(14)	22.5 x 7.5(D)	H	CV
CF-6000-795	225/195	26.5	Ford Dsl. (170 HP)	9	17.5	AT-545	010R x 22.5(14)	22.5 x 7.5(D)	H	CV
CF-6000-796	225/195	26.5	Ford Dsl. (170 HP)	9	17.5	CL-450	010R x 22.5(14)	22.5 x 7.5(D)	H	CV
CF-6000-797	225/195	26.5	Ford Dsl. (170 HP)	9	17.5(2)	CL-455	010R x 22.5(14)	22.5 x 7.5(D)	H	CV
CF-6000-798	225/195	26.5	Ford Dsl. (170 HP)	9	17.5	CL-450	010R x 22.5(14)	22.5 x 7.5(D)	H	CV
CF-6000-799	225/195	26.5	Ford Dsl. (170 HP)	9	17.5(2)	CL-455	010R x 22.5(14)	22.5 x 7.5(D)	H	CV
CF-7000-780	171/141	29.5	Ford Dsl. (170 HP)	12	21(2)	AT-545	010R x 22.5(14)	22.5 x 7.5(D)	H	CV
CF-7000-781	171/141	29.5	Ford Dsl. (170 HP)	12	21(2)	CL-455	010R x 22.5(14)	22.5 x 7.5(D)	H	CV
CF-7000-782	189/159	29.5	Ford Dsl. (170 HP)	12	21	AT-545	010R x 22.5(14)	22.5 x 7.5(D)	H	CV
CF-7000-783	189/159	29.5	Ford Dsl. (170 HP)	12	21	CL-450	010R x 22.5(14)	22.5 x 7.5(D)	H	CV
CF-7000-784	189/159	29.5	Ford Dsl. (170 HP)	12	21(2)	CL-455	010R x 22.5(14)	22.5 x 7.5(D)	H	CV
CF-7000-785	189/159	29.5	Ford Dsl. (170 HP)	12	21(2)	CL-455	010R x 22.5(14)	22.5 x 7.5(D)	A	CV
CF-7000-786	189/159	29.5	Ford Dsl. (170 HP)	12	21(2)	CL-455	010R x 22.5(14)	22.5 x 7.5(D)	H	CV
CF-7000-787	189/159	29.5	Ford Dsl. (170 HP)	12	21(2)	CL-455	010R x 22.5(14)	22.5 x 7.5(D)	A	CV

(2) - Indicates two-speed rear axle; (D) - Disc wheel; (H) - Hydraulic Brakes; (A) - Air Brakes; (CV) - Cargo Van.

CARGO

1987 "WORK-READY" - CALIFORNIA VEHICLES SPECIFICATION SUMMARY

1987 "WORK-READY" Code	WB/CA	GVW-GCW (000)	Engine	F/A (000)	R/A (000)	Trans.	Tires	Wheels	Brake Type	Vocation
CF-7000-788	189/159	29.5	Ford Dsl. (170 HP)	12	21(2)	CL-455	010R x 22.5(14)	22.5 x 7.5(D)	A	CV
CF-7000-789	207/177	29.5	Ford Dsl. (170 HP)	12	21	AT-545	010R x 22.5(14)	22.5 x 7.5(D)	H	CV
CF-7000-790	207/177	29.5	Ford Dsl. (170 HP)	12	21	CL-450	010R x 22.5(14)	22.5 x 7.5(D)	H	CV
CF-7000-791	207/177	29.5	Ford Dsl. (170 HP)	12	21(2)	CL-455	010R x 22.5(14)	22.5 x 7.5(D)	H	CV
CF-7000-792	207/177	29.5	Ford Dsl. (170 HP)	12	21(2)	CL-455	010R x 22.5(14)	22.5 x 7.5(D)	A	CV
CF-7000-793	207/177	29.5	Ford Dsl. (170 HP)	12	21(2)	CL-455	010R x 22.5(14)	22.5 x 7.5(D)	H	CV
CF-7000-794	207/177	29.5	Ford Dsl. (170 HP)	12	21(2)	CL-455	010R x 22.5(14)	22.5 x 7.5(D)	A	CV
CF-7000-795	207/177	29.5	Ford Dsl. (170 HP)	12	21(2)	CL-455	010R x 22.5(14)	22.5 x 7.5(D)	A	CV
CF-7000-796	225/195	29.5	Ford Dsl. (170 HP)	12	21	AT-545	010R x 22.5(14)	22.5 x 7.5(D)	A	CV
CF-7000-797	225/195	29.5	Ford Dsl. (170 HP)	12	21	CL-450	010R x 22.5(14)	22.5 x 7.5(D)	H	CV
CF-7000-798	225/195	29.5	Ford Dsl. (170 HP)	12	21(2)	CL-455	010R x 22.5(14)	22.5 x 7.5(D)	H	CV
CF-7000-799	225/195	29.5	Ford Dsl. (170 HP)	12	21(2)	CL-455	010R x 22.5(14)	22.5 x 7.5(D)	A	CV
CF-7000-777	225/195	29.5	Ford Dsl. (170 HP)	12	21(2)	CL-455	010R x 22.5(14)	22.5 x 7.5(D)	H	CV
CF-7000-778	225/195	29.5	Ford Dsl. (170 HP)	12	21(2)	CL-455	010R x 22.5(14)	22.5 x 7.5(D)	A	CV
CF-7000-779	225/195	29.5	Ford Dsl. (170 HP)	12	21(2)	CL-455	010R x 22.5(14)	22.5 x 7.5(D)	A	CV

(2)—Indicates two-speed rear axle; (D)—Disc wheel; (H)—Hydraulic Brakes; (A)—Air Brakes; (CV)—Cargo Van.

CARGO--Built To Get The Job Done

Put CARGO To The Test

Whatever your job, CARGO's there to handle your needs. Crowded city streets, open country roads, stop-and-go, or expressway hauling—there are no application restrictions on the tough, versatile Ford Diesel engine. Drive it where you want, as far as you want.

Put CARGO to the test: pickup and delivery, van, beverage, construction, cable-reel, platform, stake, reefer, tanker. Five wheelbases, three Ford Diesel engines, plus a big 1,000,000 RBM frame rating (CF-8000 Series) provide the flexibility and strength for the most demanding medium range application.

Over 100 Work-Ready Units To Choose From

With over 100 Work-Ready units available for quick delivery, ordering your CARGO with the exact pre-engineered componentry to fit your requirements is as easy as circling a code number.

Choose from a range of wheelbases of 153–225 inches, GVW's up to 36,000 pounds, and Ford Diesel engines of 170, 185 and 210 HP (185/210 N.A. in California).

Work-Ready CARGOs are equipped with a number of notable cab and chassis components such as: full instrumentation; non-suspended individual driver's and 2-passenger bench seats; Rockwell RS-Series rear axles; power steering and fan clutches.

World-class performance. Traditional Ford toughness. Work-Ready engineering. That's CARGO. Built to get the job done.



Rugged Components For Proven Performance

A New Idea Built On Tradition

CARGO may be a new idea from Ford. But it's an idea based on proven performance. CARGO is built on the same driveline and chassis components that have taken other Ford trucks to the top of their class—for the last 27 years.

Ford and its Premium Supplier Team are always striving for the very best in performance, reliability and economy. It's the Ford tradition.

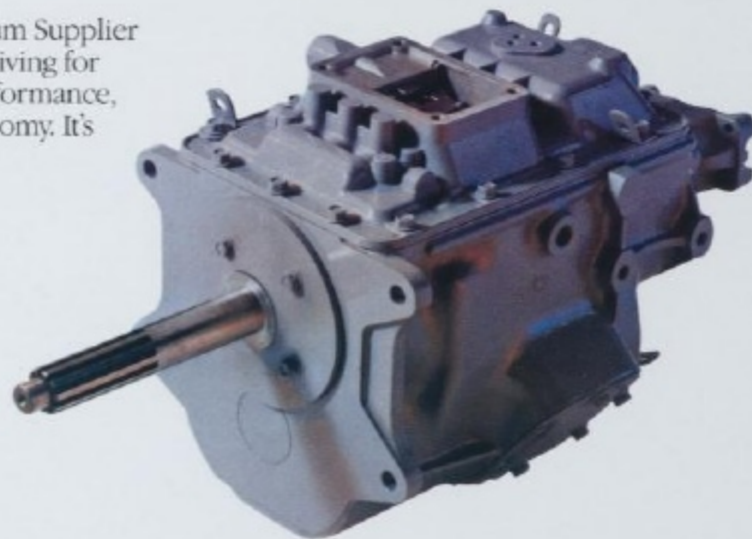

Transmissions

CARGO transmissions are designed for rugged application. Split-pin synchronizers and helical constant mesh gears were chosen for smooth shifting and quiet operation. Strength and load capacities are obtained through

the use of needle bearings on all mainshaft gears. A 5-speed, manual direct, wide-ratio transmission is standard in CARGO. Options include a 4-speed automatic (N.A. with CF-8000) and a 5-speed, manual direct, soft-fourth.

Rear Axles

CARGO offers single and two-speed rear axles with ratios chosen to fit medium/heavy applications. CARGO rear axles are designed to stand up under severe operating conditions. They feature extended life drive pinion seals, cold-formed drive pinion and involute-type axle shaft splines for high strength.



Clutch

The CARGO clutch is designed for low work effort and positive feel—tangible benefits for day-in, day-out operation. The standard clutch is a 14", single plate, pull-type with a modern diaphragm spring and a maintenance-free, lube-for-life sealed release bearing. The non-asbestos faced clutch disc features cushion springs and is torsionally dampened to minimize driveline vibration and transmission gear rattle. The actuation system is hydraulic and self-adjusts to compensate for disc facing wear.

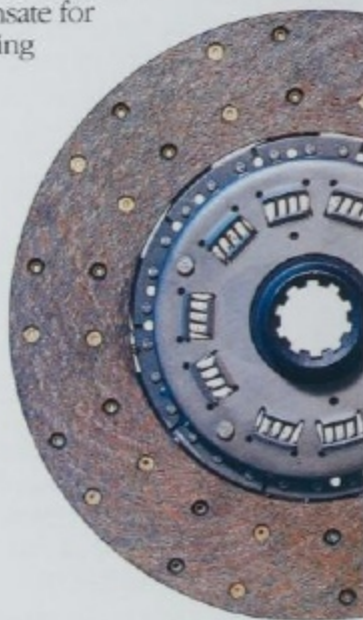

Driveline

CARGO's driveline design is the conventional U-joint and spider with slip yokes to compensate for rear suspension movement. The splines have a glidecoat application for reduced friction and improved load reduction to the center and transmission bearings. The entire system is designed to optimize operating efficiency, minimize torsional excitation and promote low levels of noise and vibration.

Maximum Payload... Maximum Maneuverability

Decreased Cost Per Load Unit

Whether you operate over-the-road, around loading docks, or both, CARGO can handle long bodies and big payloads to cut handling costs per unit of load. And that can help lower your cost of ownership.

As an added benefit, CARGO's set-back front axle and short overall length allow for increased transfer of payloads to the front axle. A great advantage in one-way operations and in applications where weight laws place loading restrictions on rear axles.

All this plus good maneuverability. CARGO's tight turning diameter (51.3 feet)—nearly 15 feet shorter than a conventional Ford F-Series medium-duty truck—means improved performance with faster trip times.

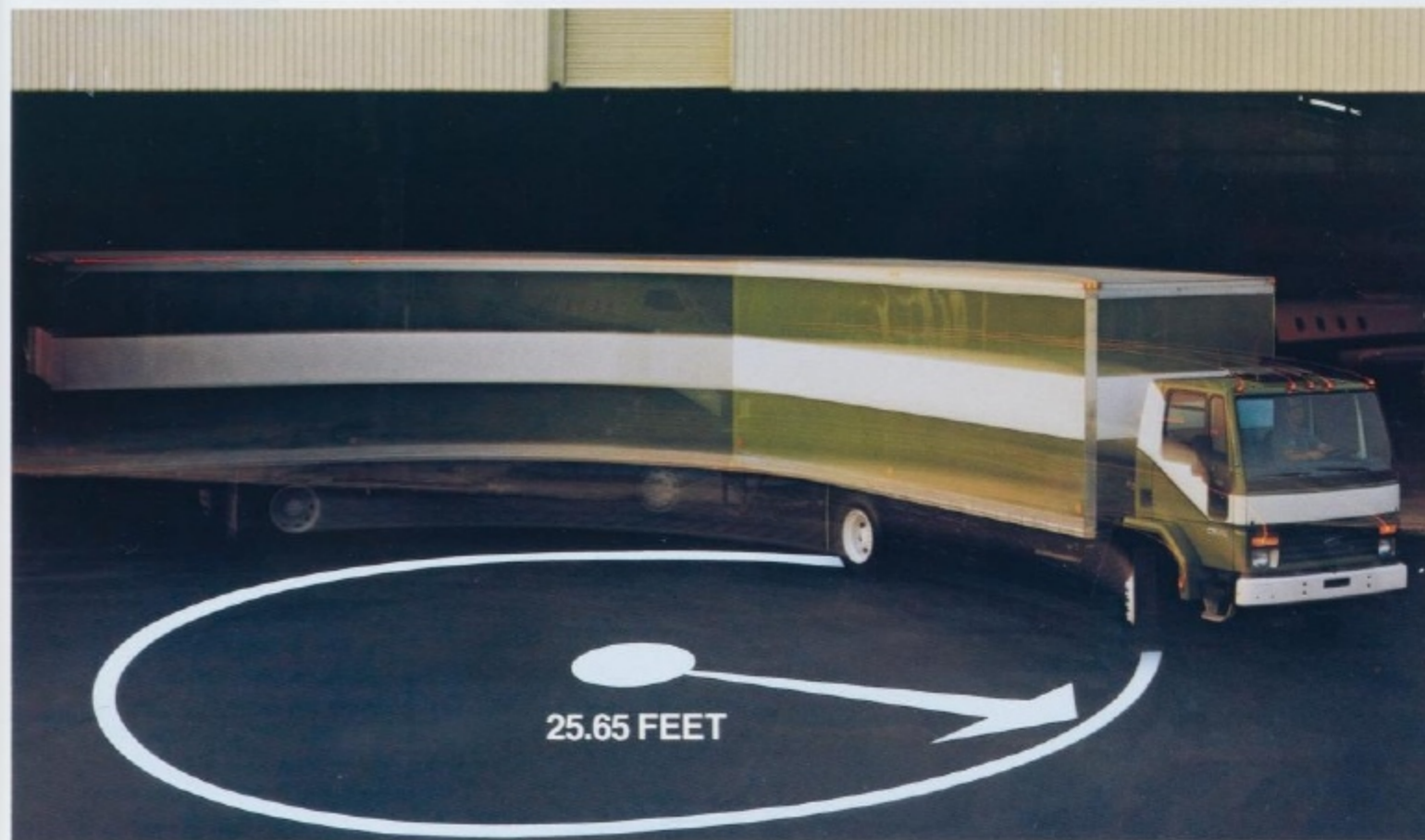

Standard Features For Added Value

Standard CARGO chassis features include: • Straight-through frame rails with smooth top flanges for easy body mounting • Extra long front and rear springs • Front shock absorbers and stabilizer bar for excellent handling and ride • Air-assisted hydraulic brakes with full-air features at hydraulic prices like spring-set rear wheel parking brakes • Front disc brakes • Radial tires.

36-Month/Unlimited Mileage Cab Corrosion Warranty

Ford protects your valuable CARGO down deep where corrosion begins and backs it with **36-month/unlimited mileage cab corrosion warranty**. Sealers, cavity waxes and zinc-coated steel are used in critical areas. Cabs are fully immersed in primer and a high-voltage electrical charge bonds the primer to the metal. Cavity wax in doors, A-pillars, quarter panels and underbody members protects against residual corrosion-producing moisture.

Baked-On Acrylic Enamel Finish

For a brilliant long-lasting finish, Ford uses carefully controlled high quality baked-on acrylic enamel paints. And special vinyl spray for the underside of fenders and floor pan helps protect against stone and road damage.



Contemporary Cab Design For Driving Efficiency

CARGO's contemporary cab has been "human engineered" for driving comfort and efficiency.

Doors that open a full 80° low, non-slip steps, and grab handles at each end of the instrument panel make for easy entrance and exit into the cab area.

Once inside, there's plenty of space for the operator and two passengers—73-inch shoulder and hip room is standard. The contoured driver's seat has 7-inch fore-and-aft adjustment for individualized support. The 2-person passenger seat is deeply contoured for maximized comfort—and it tilts forward for easy access to the cab storage area.

See The Difference A Ford Makes

Take a look around from the driver's seat and see the difference a Ford makes. CARGO's standard tinted-glass windshield and tinted strategic observation windows (includes side and rear) give the driver a full 290° field of vision—for excellent visibility when backing into tight loading docks or winding through crowded streets and alleys.

The height of the side glass and windshield depth provide the outstanding upward and downward visibility so critical to inner-city operation.

CARGO's aerodynamic configuration, together with integral deflectors, helps keep side windows and mirrors clean.



CARGO's easy-to-read instrument panel and 500 cubic-inch lockable glove box highlight its contemporary driver-friendly environment.

Custom Cab Package shown below features upgraded floor covering and a radio prep package. Air conditioning unit is available from your Dealer.

Driver-Friendly Instrument Panel

CARGO's easy-to-read instrument panel is entirely visible through the 2-spoke locking steering wheel, allowing the driver to keep his eyes on the road with only a quick, occasional glance at critical gauges.

The Fresh-Air Feeling

CARGO's climate control system, at 30 mph, completely recycles cab air every 20 seconds. Fresh air improves the operator's all-around productivity.

Custom Cab Package

Interior

- Radio Prep Package:
 - Radio Bracket
 - Speaker Wiring
 - Radio Cover Plate
 - Speaker Cover Plate
- Radio Hot Jack and Ground
- Upgraded Floor Covering
- Marker/Clearance Lamp Flasher

Exterior

- Tinted Operating Vent Windows
- Cab Latch Lock
- Windshield Wipers with Intermittent Feature



Counterbalance Cab Design
for Driving Efficiency



Low Cost Of Ownership

Service Ease

The cost of operating a business is high. That's why Ford set out to keep the cost of owning a CARGO low.

CARGO's cab is designed to set new standards for maintenance and service ease—standards that could save you money in reduced down time.

Notice, for example, how the quick-release front-access panel provides instant access to normal, everyday maintenance items such as:

- Clutch master cylinder and fluid reservoir—easily removable without dismantling the pedal assembly
- Windshield washer reservoir and pump
- Windshield wiper motor and linkage
- Brake control valve
- Air gauge connections
- Heater assembly and water connections—the complete heater unit can be easily removed for servicing.

In addition to the quick-release front panel, the front grille is easily removed, providing easy access to:

- Front cab mounts
- Lamps, horn, throttle cable and electrical connectors
- Hydraulic master cylinders & reservoirs

CARGO Limited Warranty Protection

ITEM	WARRANTY PERIOD		OWNER CONTRIBUTION	
	MONTHS	MILES	PARTS	LABOR
BASE VEHICLE	12	Unlimited	No Charge	No Charge
ENGINE	36	150,000	No Charge	No Charge
DRIVETRAIN	24	Unlimited	50%*	50%*
FRAME	60	Unlimited	50%*	50%*
CAB CORROSION PROTECTION	36	Unlimited	No Charge	No Charge

*No charge first 12 months; 50% thereafter to limits of warranty.

50° Tilt Cab

With CARGO, routine under-cab service access is made simple. An ingenious counterbalance allows one person to tilt the cab a full 50° (40° is standard—50° by releasing quick-connect bolts) with no more effort than it takes to replace the Ford Diesel's spin-on oil filters.

Behind-The-Cab Service Access

Convenient access (without tilting the cab) is provided behind the cab to the oil, fuel and air filters, the cooling system remote tank, the oil level dipstick and the fuel-water separator.

CARGO's front-access grille is easily removed, providing convenient servicing of routine maintenance items.



Ford Parts And Service Support

Ford backs your CARGO with a network of parts and service centers supporting over 260 Ford Heavy Truck dealers nationwide.*

Ford Parts and Service Division also provides technical service training and publications, special service tools and equipment and technical service assistance.

*Nearly 600 Ford Dealers nationwide are Ford Diesel engine certified.



Ford CARGO Specifications

SERIES		6000	7000	8000
GVW RATING LBS.		26,500	29,500	33,000/36,000*
GCW RATING LBS.		None		
AXLES—FRONT	Std.	9,000 lb.	12,000 lb.	12,000 lb.
	Opt.	17,500 lb. Single Speed 4.56	21,000 lb. Single Speed 4.88	21,000 lb. Single Speed 4.88
—REAR	Std.	17,500 lb. 2-Speed 4.56/6.36	21,000 lb. 2-Speed 4.88/6.80	21,000 lb. 2-Speed 4.88/6.80
	Opt.		21,000 lb. 2-Speed 4.56/6.36	23,000 lb. 2-Speed 4.88/6.65 (with 36,000 lb. GVW)
AXLE EQUIPMENT	Std.	Power Steering		
	Std.	Front Shock Absorbers		
	Std.	Front Stabilizer Bar		
BRAKES	Std.	Split Power—Air Assisted Hydraulic—Disc Front Drum Rear		
	Opt.	Full Air		
BRAKE EQUIPMENT	Std.	Air Compressor—9.5 CFM		
	Std.	Parking Brake—Spring Set		
ELECTRICAL	Std.	Alternator, 60 Amp, 900 Watt		
	Opt.	Alternator, 75 Amp, 1125 Watt		
	Std.	Battery, Low Maintenance, 2—12 Volt, 535 CCA (63 Amp Hr.)		
ENGINE	Std.	Ford Diesel—170 HP		Ford Diesel—185 HP†
	Opt.			Ford Diesel—210 HP†
ENGINE EQUIPMENT	Std.	14" 1-Plate, Pull-type Clutch		
	Std.	Fan Clutch, Viscous-type		
	Std.	Hand Throttle		
	Std.	12-Volt Starter		
	Opt.	Exhaust Brake, Automatic		
	Opt.	Either Cold Start		
FRAME	Std.	510,000 RBM	153" WB—510,000 RBM 171"-225" WB—900,000 RBM (Incl. Inverted "L" Reinforcements)	750,000 RBM
	Opt.	Dual 40-Gal. FHWA, Rectangular		
FUEL TANK	Std.	40-Gal. FHWA, Rectangular		
	Opt.	Dual 40-Gal. FHWA, Rectangular		
SUSPENSION COMBINED RATING @ GROUND	Std.	9,000 lb.	11,000 lb.	12,000 lb.
	Opt.	17,500 lb.	18,500 lb.	22,000 lb.
TIRES	Std.	10R x 22.5—14PR Tubeless Radial		011R x 22.5—14PR Tubeless Radial
WHEELS	Std.	22.5 x 7.5—8-Hole, Disc	22.5 x 7.5—10-Hole, Disc	
WHEEL SEALS	Std.	Unitized		
	Std.	Two-Piece, Wet-type		
TRANSMISSIONS	Std.	5-Speed, Manual Direct—Wide Ratio		
	Opt.	4-Speed Automatic (N.A. with CF-8000)		
	Opt.	5-Speed, Manual Direct—Soft Fourth		
UNIVERSAL JOINTS	Std.	1550 Size		1610 Size

*Optional GVW requires: 13,000 lb. front axle and suspension; air brakes; 210 HP engine; 23,000 lb. single speed 4.89 rear axle and suspension; 1,000,000 RBM frame (includes Outside Channel Reinforcement) and 16 ply tires with 8.25 wheels. †N.A. California.

Dimensions

CARGO

WB	BBC*	CA	AF	OAL
153"	80"	123"	78"	284"
171"	80"	141"	84"	308"
189"	80"	159"	90"	332"
207"	80"	177"	96"	356"
225"	80"	195"	102"	380"

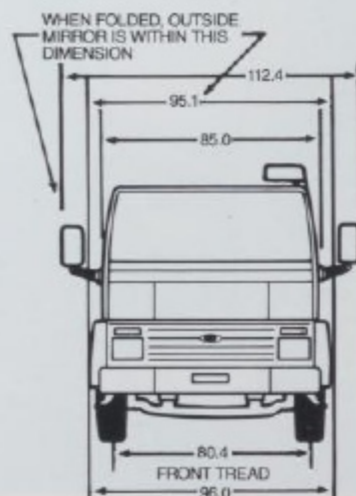
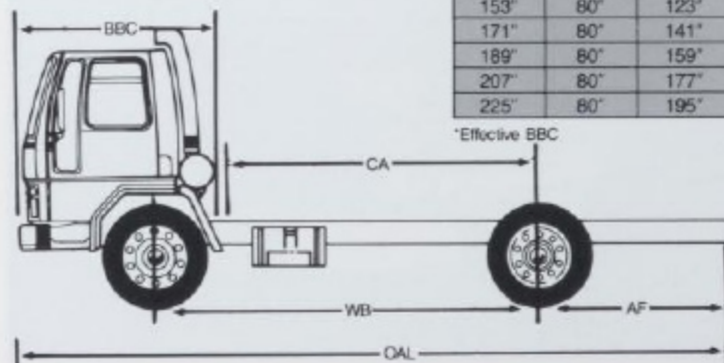

CARGO Standard Equipment

Standard Interior

- Assist Handles—LH & RH Side (in-dash)
- Ash Tray
- Cigar Lighter
- Dome Light and Courtesy Switch
- Padded Dash
- Sun Visors—LH & RH Side
- Heater and Defroster, Fresh Air
- Parking Brake On/Off Control w/Air or Hydraulic Brakes
- Cloth Headlining and Back Panel
- Seat Trim—Black Vinyl
- Seats—Driver's Individual Non-Suspension Type (Suspension Type Driver's Seat Optional) —Passenger's, 2-Passenger Bench Type, Flips Forward
- Steering Wheel—20" Soft Feel
- Stowage Pocket on Doors
- Coat Hooks—Two
- Glove Compartment, Lockable
- Armrest/Door Pull—Both Doors
- Observation Window Trim Panel
- Cowl Fresh Air Vents—LH & RH
- Safety Belts
- Wheel Nut Wrench
- Key Check for Warning Lights
- Locking Steering Column

Standard Exterior

- Bumper, Full-Width Front, Steel, Painted
- Horn, Single Electric
- Headlights—Halogen, Rectangular
- Mirrors, LH & RH w/Integral Convex
- Taillights, Includes Stop, Turn (Amber), Backup and License Plate (LH Only) Light
- Side Marker Lights, Mounted on Fender
- Tow Pin—Front
- Turn Signal Lights, Front—Grille Mounted
- Five Cab Clearance and Identification Lights
- Vent, Roof
- Glass, Tinted—All Around
- Windows, 1 Large Observation Type in Doors
- Window, Fixed Vent (Tinted)
- Windows, 2 Large Back-of-Cab
- Windshield, Laminated; All Other Glass Tempered
- Windshield Wipers, 2-Speed and Electric Washers

Options Availability

Options displayed or described in this catalog are available at extra cost and may be offered in combination with other options or subject to additional ordering requirements or limitations. Your Ford Dealer has the latest information.

Product Changes

Ford Truck Operations reserves the right to change product specifications at any time without incurring obligations. It is important to note also that some of the items shown on vehicles in this publication are available through retail organizations and establishments not connected with Ford Motor Company. Availability, price, quality and durability of these items rest solely with the respective manufacturers and their sales organizations and Ford assumes no responsibility for their use.

Federal Regulations

Federal regulations such as those issued by the National Highway Traffic Safety Administration, the Environmental Protection Agency or the Federal Highway Administration or issued pursuant to the Occupational Safety and Health Act (OSHA) and/or state and local laws and regulations, may require additional equipment for the particular use you intend for the vehicle. It is the buyer's responsibility to determine the applicability of such laws and regulations to the buyer's intended use for the vehicle, and to arrange for the installation of required equipment. Your Ford Dealer has information about the availability of many items of equipment which can be ordered for the vehicle.

"Ask Your Ford Dealer"

Following publication of this catalog, certain changes in standard equipment, options, prices and the like, or product delays, may have occurred which would not be included in these pages. Your Ford Dealer is your best source for up-to-date information.



With Ford, You're Never Far From Home!



Toll-Free Sales & Service Hotline

Call toll-free 1-800-FORD 1ST (367-3178)* for information concerning CARGO sales, parts and service facilities. Operators are ready to take your call from 8 A.M. until 8 P.M. (EST). With Ford, you're never far from home.

*In Alaska call 1-800-433-6292.

- Regional Sales Offices
- District Sales Offices
- Parts Distribution Centers
- Heavy-Duty Truck Dealers

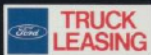

FORD PARTS AND
SERVICE DIVISION



Ford Means Business In Big Trucks



FTO-3106 Litho in U.S.A. 2/87

FORD CARGO

TRUCK OPERATIONS

