

Ford Transit ChassisCabs

Feel the difference



If the tiling on the opposite page makes you feel a little uneasy, then we speak the same language.

Just like us, you believe in doing a professional job.
Just like us, it's a matter of pride.

That's why all our commercial vehicles – and the service that stands behind them – are designed to help make your business run like clockwork.

It's simply a matter of one professional dealing with another. You wouldn't expect anything less from us.

Create the right impression

The first rule in business is to create the right impression. And there's no better way to do that than to arrive in style. So the Ford Transit Chassis Cab range represents some of the best looking and most adaptable vehicles available. No matter which model you choose, you can be sure that they each share the same tough credentials and work-hungry attitude. They provide a solid, versatile platform for all types of bespoke bodywork. Because you only get one chance to make a great first impression.

For more information, please visit: www.ford.co.uk

Model: Transit Double Chassis Cab LWB 3.2L 200PS 1-Way Tipper
Option: (at extra cost) metallic paint



Vehicle shown features optional equipment at extra cost

Comfort and control

The Ford Transit's superb car-like interior perfectly complements its dynamic exterior style. Its modern instrument panel gives the cab a light and luxurious feel, and is brimming with innovative stowage features. Clear instruments and easy-to-use controls help make your time at the wheel more relaxing and enjoyable, while reinforcing the high level of quality and craftsmanship to be found throughout the entire vehicle.



Model: Transit MWB Tipper
Options: (at extra cost) Front fog lights, metallic paint

Built to work

Drivers today generally spend more time in their vehicles than ever before. So the Ford Transit delivers an exceptional driving experience, with a choice of efficient, powerful engines, responsive handling and confident high-speed cruising, to make the toughest day's work easier to bear.



Models: (Top) Transit SWB Chassis Cab,
(Bottom) Transit LWB EF Double Chassis Cab



Rear anti-roll bar is standard on all dual rear-wheel Chassis Cab derivatives.



Engineered from the ground up to get the job done, the Ford Transit Chassis Cab range offers the widest possible choice in terms of load length, payload and passenger carrying ability. Choose from three wheelbases, four frame lengths, rear- or front-wheel drive, high traction dual or single rear wheels and single or double cab body-styles.

Solid foundation

Since its launch, the Ford Transit has been the platform of choice for chassis cab conversions. Throughout the entire design process, Ford has worked closely with the bodybuilding industry to ensure that all standard body types, and the majority of specialist conversions, can be fitted easily and efficiently, with little or no modification required.

Each derivative has a strong, robust ladder-frame chassis that provides a flat, strong base on which to build, with integral body mounting points and low frame rails. From a standard box van, dropside or tipper to a refrigerated van, mobile workshop or emergency service vehicle, the Ford Transit forms a tough and dependable foundation for your business.

Chassis

- Flat, straight top of frame
- Three gross vehicle weights: 3000 kg, 3500 kg and 4600 kg.
- 350HD (Heavy Duty) version also available for operators requiring greater loading latitude from a 3500 kg GVM vehicle
- Wheelbase and overhang dimensions suitable for industry-standard body sizes: 2.8, 3.2, 3.65 and 4.0 m
- Designed to accommodate non-standard body sizes, either larger or smaller than nominal industry-standard
- Body widths up to 2.05m (300) 2.2m (all 350 and 460 models)
- Robust inverted closed 'top hat' section pressed high tensile steel frame (double 'top hat' for 350HD and 460 models)
- Integral body mounting points, and bolt-on saddle brackets for 350HD and 460 models
- Removable rear closing member and rear lights, catering for different rear overhangs
- Easily fitted bolt-on rear frame overhangs, where required
- High centre of gravity suspension as standard to cope with large bodywork

Cab Styles

The Ford Transit Chassis Cab range is available with either a single cab or double cab configuration.

Single cab is the traditional choice, offering flexibility to fit a multitude of conversion possibilities – including the Ford Transit One-Stop Shop range.

The double cab is a great solution for moving crew and load at the same time with six seats as standard or seven with the optional quad seat.

The double 'utility' cab SVO option removes the rear seat altogether and blanks the side windows. One Stop models specified with this option can be coupled with an OSS supplier fit bulkhead to form a secure area for locking away equipment and tools.

Rear-wheel configuration

Dual or single rear wheels are available to ensure the Ford Transit Chassis Cab matches your operational and bodywork needs exactly.

- Dual rear wheels – Standard on all 3.5T, 3.5T HD and 4.6T models. Provides increased rear axle capacity and loading latitude. Best all-round combination, but ideally suited to high payload/high traction requirements and towing. Available only with rear-wheel drive
- Single rear wheels – Optional on rear-wheel drive 3.5T models, and standard on all front-wheel drive models. Ideally suited to narrow bodywork where vehicles are used in confined metropolitan, rural or urban environments. Available with both front- and rear-wheel drive. Further benefits include reduced fuel consumption*, especially when combined with front-wheel drive

*Ford homologation figures.

Electronic Stability Programme

ESP incorporating ABS, senses when the vehicle is deviating from the driver's chosen line and automatically applies the necessary power and braking adjustments to correct its road position.

Brake Assist – a system that detects emergency braking and automatically applies maximum braking effort to potentially reduce the stopping distance.

Brake Traction Control System (BTCS) to aid traction when starting from rest.

Hill Launch Assist (HLA), to prevent the vehicle from rolling back when pulling away on a slope.

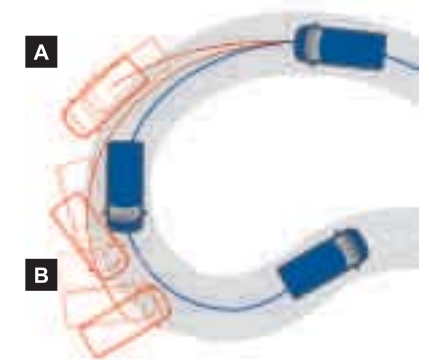

— Vehicle with ESP.
— Vehicle without ESP.

A Vehicle experiences understeer on approach.

B Vehicle experiences oversteer on exit of bend

Detachable rear member simplifies bodybuilding applications.



Model: Transit SWB Dropside
Options: (at extra cost) metallic paint

Digital tachograph
 Latest digital tachograph sets new standards for performance, technology, design and tamper proofing (may be a legal requirement on some models).



The Ford Transit Chassis Cab's advanced diesel engine range features the latest common rail fuel-injection technology. The Superb torque characteristics mean that the engine reacts instantaneously to your input, even when heavily laden.

Power you can count on

Energy Management

All FWD and RWD Chassis Cabs are equipped with twin batteries as standard. This arrangement allows the second battery to power whatever accessory is needed when the engine is switched off, leaving the primary battery in a high state of charge for dependable start and run operation.

Advanced technology

Across the range, our Duratorq TDCi diesel engines use advanced design and technology to boost performance and optimise efficiency. The latest common-rail fuel-injection system helps shape a hard-working combination of horsepower and torque for superior load carrying and towing capability.

All engines comply with Stage IV emissions legislation. Stage IV is the latest legal requirement needing 50% reductions in oxides of nitrogen (NO_x) and 40% reductions in particulates below previous Stage III levels.

Pulling power

For some operators, towing is an everyday way of life; for others, it is an occasional event. With up to 470 Nm of torque available, and maximum Gross Train Mass (GTM) ranging from 3500 kg to 6500 kg*, the Ford Transit is thoughtfully designed to cope with whatever demands you make.

All 2.4 TDCi RWD chassis cabs are now fitted with a single mass flywheel as standard to improve durability under extreme driving conditions.

*Depending on engine, transmission and final drive ratio.

3.2 Duratorq TDCi engine

A high-power 3.2-litre 5-cylinder Duratorq TDCi diesel engine is the latest addition to the Ford Transit engine range. Developing an impressive 200 PS and a mighty 470 Nm of torque, it is one of the most powerful diesel engines in its class. Available for 350, 350HD and 460 RWD models, it comes coupled to an upgraded Durashift 6-speed manual transmission.

Long-range fuel tank

The 103-litre fuel tank offers an extra 23 litres capacity over the standard tank for less frequent fuel stops, saving you both time and money. Available on rear wheel drive models (except short wheelbase).

All-wheel drive

When the going gets tough, trust Ford Transit's advanced electronically-controlled all-wheel drive system to see you through with ease. Available on single rear wheel derivatives with the 140 PS Duratorq TDCi engine – coupled to a 6-speed manual transmission – it is the ideal choice when extra traction is required in poor driving conditions, such as snow, rain, mud or gravel.

Together we can care for the environment

Thanks to smart ideas and clever refinements, Ford's advanced technology is creating cleaner, more fuel-efficient vehicles today.

We're working to reduce your costs

From our fuel-efficient Duratorq TDCi diesel engines to 6-speed manual transmissions; coated Diesel Particulate Filters to revised final drive ratios, our affordable technologies are providing benefits to the environment – and your pocket.

Other initiatives, such as gearshift indicator lights and speed limiters, provide a helpful aid to using less fuel, and encourage a smoother driving style.

A sustainable future

Ford vehicles are among the most environmentally efficient on the road, but our commitment to a sustainable future reaches far beyond our model range and into other areas of operation.

Across Europe, many of our facilities now receive their electricity from renewable sources, including wind, solar, hydro and waste generation, helping to further reduce our carbon footprint.

Speed limiter

Available on all diesel models with speed limits set for specific needs.



Taking a leading role in recycling

Ford is continually aiming to improve the recyclability of its commercial vehicles.



Shift indicator light

Tells you the optimum time to change gear. (Available on all diesel models)



Coated diesel particulate filter (cDPF)

Maintenance-free cDPF reduces exhaust particulate emissions. (Available on all diesel models)



Award-winning eco plant

Our Dagenham Diesel Centre (UK) derives all its electricity from renewable sources.





The power to deliver a top quality job is the key to success in any business. So our comprehensive range of engines and transmissions has been developed to withstand the rigours of working life. Add to that the choice between front- and rear-wheel drive, and the confidence-inspiring new full-time all-wheel drive system, and you can trust the Ford Transit to put out the muscle when you need it most.

Driven by the way you work

Why front-wheel drive?

- Lower kerb weight, improved payload
- Lower frame height
- Improved fuel economy

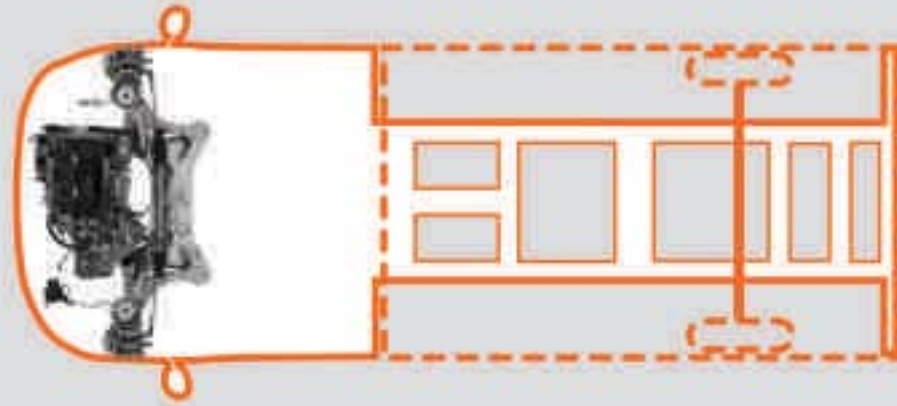

Diesel (FWD)

2.2 Duratorq TDCi engine, available in two power and torque configurations:

- 115 PS/300 Nm
- 140 PS/350 Nm

Transmissions

- Durashift 6-speed manual transmission

Diesel (FWD)

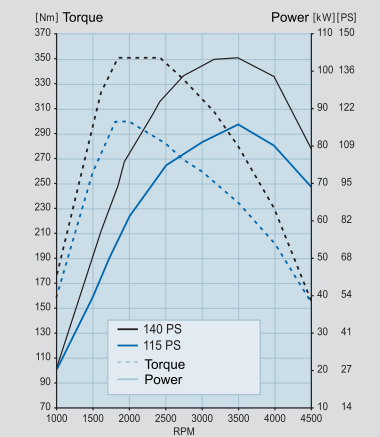

Why rear-wheel drive?

- Versatile and traditional choice for Chassis Cabs
- Best suited for heavier duty applications
- Best payload latitude – the ability to cope with variable payload positions
- Ideally suited for towing applications
- Dual rear wheels are standard on all 3.5T GVM Chassis Cabs for improved traction and rear axle capacity
- Single rear wheels available for narrow bodywork

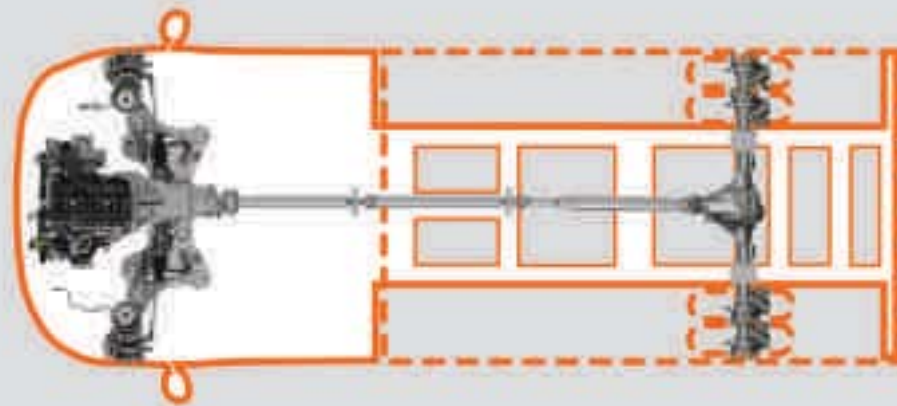

Diesel (RWD)

2.4 Duratorq TDCi engine, available in three power and torque configurations:

- 100 PS/285 Nm
- 115 PS/310 Nm
- 140 PS/375 Nm

3.2 Duratorq TDCi 5 cylinder engine:

- 200 PS/470 Nm

Transmissions

- Durashift 5-speed manual transmission (100 PS TDCi diesel)
- Durashift 6-speed manual transmission (115 PS / 140 PS TDCi diesel)

Diesel (RWD)



Why all-wheel drive?

- Additional traction in difficult driving conditions, such as loose surfaces or heavy snow
- 'Intelligent' automatic system requires no driver input
- Under normal conditions drive is directed to just the rear wheels. In slippery conditions, the system increases drive to the front wheels to enhance traction
- Suited for rescue services or utility companies where field and track work is frequently undertaken

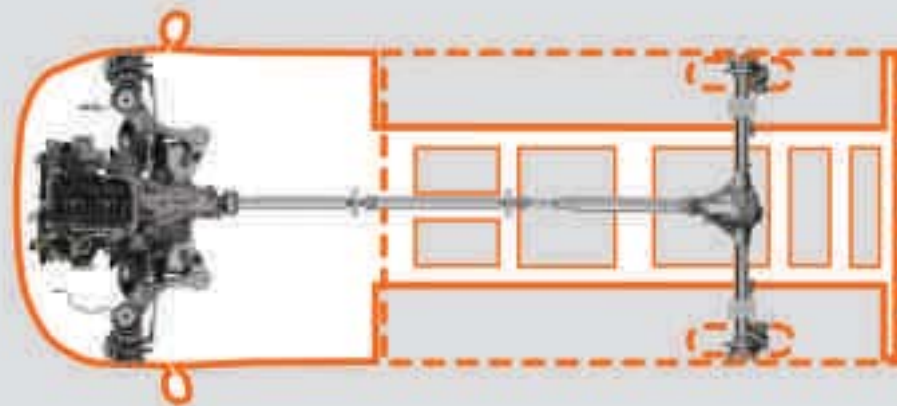

Diesel (AWD) - 350M model

2.4 Duratorq TDCi engine:

- 140 PS/375 Nm

Transmission

- Durashift 6-speed manual transmission

Diesel (AWD)

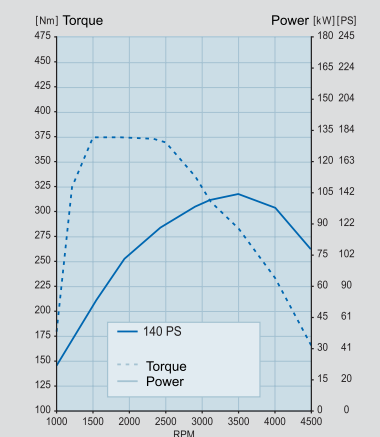

Short wheelbase

The short wheelbase Ford Transit Chassis Cab combines a strong ladder-frame chassis with a choice of front- or rear-wheel drive and now with a choice of 3000 kg or 3300 kg gross vehicle mass.

300SWB

Chassis Cab

- Front or rear-wheel drive
- Single rear wheels
- 3137 mm short wheelbase
- 2.85 metre/9 ft 4 in nominal internal body length
- 1323 – 1444 kg gross payload
- 3000 kg gross vehicle mass (GVM)
- 3500 kg maximum gross train mass (GTM) – FWD (SRW)
- 5000 kg maximum gross train mass (GTM) – RWD (SRW)
- Turning circle (kerb to kerb) 11.4m

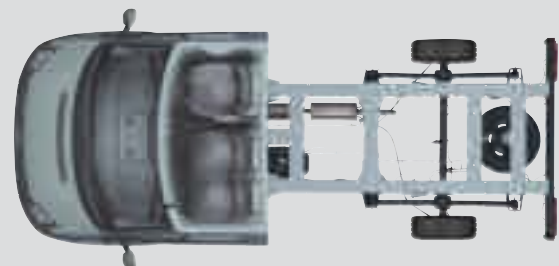
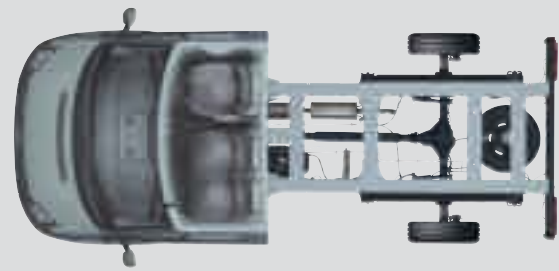

Choose your payload and your cab style with the hard-working medium wheelbase Ford Transit Chassis Cab.

Medium wheelbase

350/HD350/460MWB

Chassis Cab

- Rear-wheel drive with dual rear wheels (single rear wheels optional – 350 only)
- All-wheel drive with single rear wheels (350 only)
- 3504 mm medium wheelbase
- 3.2 metre/10 ft 6 in nominal internal body length
- 1616-1726 kg gross payload – 350M RWD (DRW)
- 1660-1771 kg gross payload – 350M RWD (SRW)
- 1656 kg gross payload – 350M AWD
- 1584-1660 kg gross payload – HD350M
- 2646-2724 kg gross payload – 460M
- 3500 kg or 4600 kg gross vehicle mass (GVM)
- 6500 kg maximum gross train mass (GTM), depending on engine/driveline combination
- Turning circle (kerb to kerb) 12.5 m

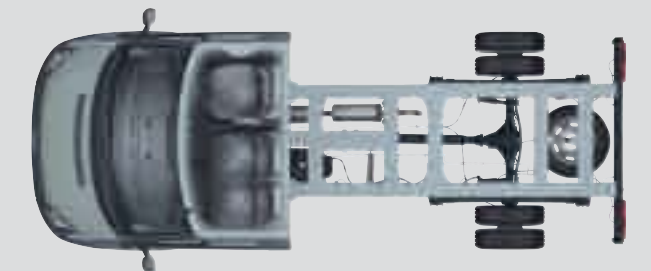

Long wheelbase

The long wheelbase Chassis Cab is the ideal basis for 3.66 metre/12' 6" nominal body applications, and the Double Chassis Cab is the perfect platform for tipper conversion.

350 /HD350/460 LWB Chassis Cab

- Rear-wheel drive with dual rear wheels (single optional – 350 only)
- 3954 mm long wheelbase
- 3.66 m/12 ft nominal body length
- 1578-1688 kg gross payload – 350L RWD (DRW)
- 1620-1750 kg gross payload – 350L RWD (SRW)
- 1611 kg gross payload – HD350L
- 2673 kg gross payload – 460L
- 3500 kg, or 4600 kg gross vehicle mass (GVM)

- 6300 kg maximum gross train mass (GTM), depending on engine/driveline combination
- Turning circle (kerb to kerb) 13.9 m

350/HD350/460 LWB Chassis Double Cab

- Rear-wheel drive with dual rear wheels
- 3954 mm long wheelbase
- 2.85 metre/9 ft 4 in nominal internal body length
- 1500-1611 kg gross payload – 350L
- 1457-1534 kg gross payload – HD350L
- 2517-2596 kg gross payload – 460L
- 3500 kg or 4600 kg gross vehicle mass (GVM)
- 6300 kg maximum gross train mass (GTM), depending on engine/driveline combination
- Turning circle (kerb to kerb) 13.9 m

For the greatest frame length and load-carrying ability, look no further than the accommodating Ford Transit Chassis Cab long wheelbase EF.

Long wheelbase extended frame

350/HD350/460 EF Chassis Cab

- Rear-wheel drive with dual rear wheels (single rear wheel optional – 350 only)
- Front-wheel drive with single rear wheels (350 only)
- 3954 mm long wheelbase extended frame
- 4.0 metre/13 ft 1 in nominal internal body length
- 1604-1715 kg gross payload – 350 RWD (SRW)
- 1561-1673 kg gross payload – 350EF DRW
- 1530-1607 kg gross payload – HD350EF
- 2591-2669 kg gross payload – 460

- 3500 kg or 4600 kg gross vehicle mass (GVM)
- 6500 kg maximum gross train mass (GTM), depending on engine/driveline combination
- Turning circle (kerb to kerb) 13.9 m

350/HD350/460 EF Chassis Double Cab

- Rear-wheel drive with dual rear wheels
- 3954 mm long wheelbase extended frame
- 3.2 metre/10 ft 6 in nominal internal body length
- 1482-1592 kg gross payload – 350EF
- 1450-1527 kg gross payload – HD350EF
- 2509-2588 kg gross payload – 460EF
- 3500 kg, or 4600 kg gross vehicle mass (GVM)
- 6500 kg maximum gross train mass (GTM), depending on engine/drivetrain combination
- Turning circle (kerb to kerb) 13.9 m

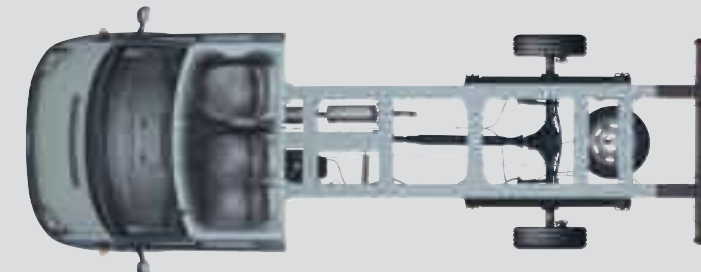
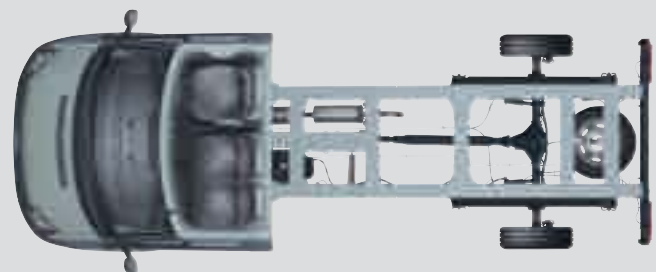
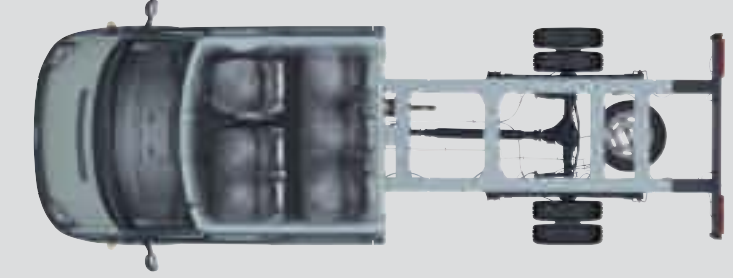
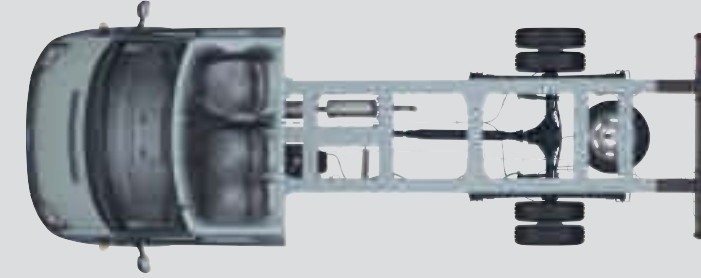
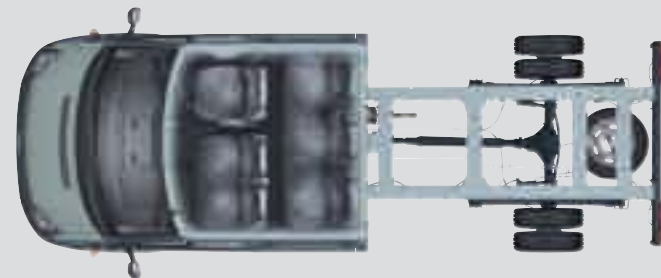
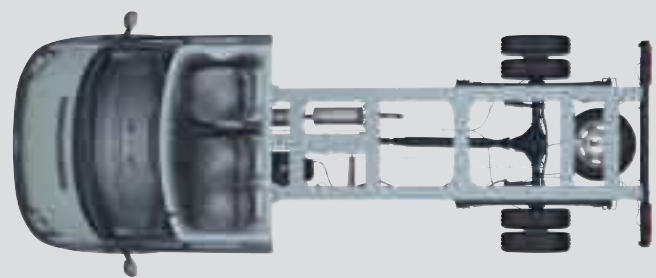

Transit

Chassis Cab

The Ford Transit Chassis Cab is remarkably well equipped. Its superbly designed instrument panel and generous stowage features reinforce the high level of quality and craftsmanship to be found throughout the entire vehicle.



Exterior features

- Tinted glass
- Electrically-operated windows
- Remote central locking

Interior features

- Model 6000 RDS stereo radio/CD player with auxiliary MP3 connector and steering column-mounted controls
- Driver's and passenger's side facia-top stowage compartments with lids
- 12-volt power point on driver's side
- Central storage for A4 binder or clipboard
- Passenger's side open storage bin
- Centre-mounted car park ticket/toll holder
- Facia-mounted swivelling tray with two cup holders and pen slot
- Glovebox with rails designed to take A4 hanging files
- Two 2-litre bottle holders
- Driver's side door pocket
- Height-adjustable passenger seat belt
- Heater with air recirculation feature

Option packs available:

Appearance Pack

- Body colour bumper
- Front fog lights
- Full wheel covers (SRW only)
- Bodyside mouldings

Trunker Pack

- Cruise control
- Trip computer

Visibility Pack

- Quickclear heated windscreen
- Electrically-operated and heated door mirrors

Premium Visibility Pack

- Quickclear heated windscreen
- Electrically-operated and heated door mirrors
- Automatic headlights
- Rain-sensing front wipers
- Front fog lamps
- Instrument panel dimmer



Ford Transit One-Stop

The Ford Transit is renowned for its versatility and flexibility, and is the ideal platform for a wide range of specialist applications and bespoke conversions. What's more, for the convenience of those operators who want a quick and simple, work-ready solution, Ford offers the Transit 'One-Stop' range of bodied chassis cabs.





Strong, Rugged and purposeful, the Ford Transit Tipper represents superb functionality, coupled with quality of design and manufacture. Seen as a versatile, reliable partner by a wide range of industries where safety and productivity are paramount. The Transit Tipper has been independently certified by the TUV for safety and production conformity; an industry first.

One-Stop 1-way Tipper

Tipper trucks are expected to operate in adverse conditions and subject to a wide range of payloads. So the Transit's dual rear wheel, rear-wheel drive configuration provides excellent traction and loading latitude often required on and off site.

Need a crew of 6 on site, along with tools and raw materials? The Double Cab Tipper provides the quick, flexible solution often required in construction and allied trades.

In addition to the high specification of the 1-way Tipper, a wide range of options are available, including mud and snow tyres, tow bar and special paint colours. Double cab models can also be specified with a quad crew seat with useful under-seat stowage.

Optional bodywork equipment is available from the bodywork supplier via your Dealer. Typical options include a remote wander lead pendant hand controller, polytarps, toolboxes, amber beacons, tow bars with a range of ball or clevis couplings 7, 7+7, or 13 pin electrical sockets, chevrons, ply or polypropylene load liners and rear light guards. Together, they enable the vehicle to be tailored to meet the specific demands of the operator, saving you both time and money.

Features include:

- 1-way tipping capability – rear
- Top and Bottom hinged tailboard standard
- Available on 350 MWB Chassis Cab and 350 LWB Double Cabs
- Powder coated, hot dipped galvanized steel construction
- Tough roll form to rear floor edge
- Body colour dual skin aluminium side and tailboards
- Pull up load lashing points in load bed
- Sheeting hooks to underside of load bed, front headboard and rear
- 5 stage chrome plated underfloor ram
- 2kW electro-hydraulic power pack
- 50 degree tip angle
- TÜV 98/37/CE safety and production conformity approved
- 3 year 100,000 mile warranty

Standard dual mode top and bottom hinged tailboard. Top hinged or 'Tip-thru' operation controlled by side mounted remote lever.



Full-height steel bulkhead with ladder gantry and stops. Upper, lower and mid-level load lashing system capable of securing a wide range of loads and equipment.



Side pillar-mounted steel latches for sideboards and tailboard. Handle folds out of the way when unlatched and is removable for repair or replacement.



Bottom hinged or 'Tip-over' tailboard configuration controlled by latches mounted in the rear pillars, suitable for most applications especially large bulk loads



Dash-top tipper control module, microprocessor-controlled with integral emergency stop. LCD status control window with LED and acoustic warnings.



Tipper isolation switch, conveniently mounted adjacent to the driver. The switch safely isolates the entire system when not in use, or during routine maintenance.



3.2 m/10ft 4in 350M.



2.85 m/9ft 4in 350L Double Cab.



New to the One-Stop programme is the Ford Transit 3-way Tipper. Engineered to the same high standards as the 1-way Tipper, with the added benefits of tipping to both sides of the vehicle, as well as to the rear.

One-Stop 3-way Tipper

The 3-Way Tipper represents the ultimate in site vehicle versatility, especially useful with restricted access sites. In addition to the standard dual mode top and bottom hinged tailboard, the sideboards can be retained by chains to dispense the load away from the vehicle, or dropped fully to allow easy material loading and off-loading.

Robustness and durability are qualities that every Tipper operator is looking for. Any items that are likely to get damaged

or worn are designed to be replaced and maintained easily, to help reduce downtime and maintenance costs.

Features include:

- 45-degree tip angle – rear, nearside, offside
- Chrome-plated 5-stage underfloor ram with built-in shock absorber
- Tough roll form edge to load deck sides and rear

- Plug-in wander lead pendant control handset
- Heavy-duty 150A alternator
- Twin battery electrical system
- Top and Bottom hinged Tailboard
- Sideboard 90° retaining chains
- TÜV certification for safety and production conformity



Standard hand held remote pendant wander lead handset. Plugs into socket below drivers seat giving the operator control when side tipping.



8 pull up load anchorage rings, flush mounted in load deck.



Integral body prop, essential for routine maintenance and inspection.



5 stage chromium plated ram mounted in a steel gimble with electrical limit switch's controlling angle of Tip.



Configuration bar ensures correct fitment of pivot index pins to enable side or rear tip pivot configurations.



Sheeting hooks mounted to all four sides of body to facilitate secure sheeting of loads.



Pivot pins control the tip configuration by locking or releasing ball and socket body pivots.



Top hinged or 'Tip-thru' operation controlled by side mounted remote lever, bottom hinged controlled by pillar mounted latches.



Top hinged or 'Tip-thru' tailboard ideal for 'fluid' loads such as sand, gravel and top-soil.



3.2m/10ft 4in 350M



2.85m/9ft 4in 350L Double Cab



The Ford Transit Dropside is a stylish, easy-to-drive vehicle for operators seeking a cost-effective, yet professional image for their business. With payloads ranging between 1 and 1.5 tonnes, and body lengths from 2.85 metres to 4.05 metres, there is a model to suit most operating needs.

One-Stop Dropside

Load security is a key consideration for Dropside users, so a generous number of lashing points are provided, whilst a pair of stirrup steps and twin grab handles afford easy access to the load area.

The Dropside's flexibility is further enhanced by its removable side and tailboards, and removable rear corner pillars, which enable awkward loads to be carried. What's more, components that are subjected to heavy wear and tear are designed to be easily repaired or replaced.

To complement the Dropside, a range of options from the bodywork supplier are available to ensure more specific requirements are met. Tail-lifts, loader cranes, toolboxes, beacons and bespoke paint schemes can be specified to meet the demands of an increasing variety of operating tasks.

Features include:

- Replaceable resin-bonded 15 mm ply load deck
- Substantial all-steel powder-coated headboard
- Removable sideboards, tailboard and corner pillars for flatbed operation
- Flush-mounted load-lashing rings to raves, plus roping eyes to underside of raves
- Double skinned body colour aluminium side and tailboards with integral bump rubber
- Robust, lightweight aluminium and steel subframe
- Half round thermoplastic fenders
- 3 year 100,000 mile warranty



2.85 m/9ft 4in 300S.



3.2 m/10ft 6in 350M.



3.65 m/12ft 350L.



4.05 m/13ft 3in 350EF.



2.85 m/9ft 4in 350L Double Cab.



3.2 m/10ft 6in 350EF Double Cab.

Left and right hand stirrup step and grab handle ease entry into load area



Removable corner pillars enable the Dropside to be converted into a Flatbed when combined with board removal.



Easy to operate overcentre cam latches provide secure board retention.



Strong tubular steel headboard provides protection to cab and facilitates ladder carriage when required



Pull-up load retention rings sit flush with the load platform when not in use.



Underfloor mounted hooks for securing load sheets.





Rear

Optional internal equipment shown

4.0m/13ft 350 EF – optional equipment shown

The new Transit CurtainSlider represents the latest in bodywork design, giving unparalleled load access with innovative and practical features to ease everyday operating tasks. Sliding, semi rigid curtains provide a neat, attractive solution for pallet loads used in the Distribution and Just-in-Time industries, where productivity and load turn-around are critical.

One-Stop CurtainSlider

The CurtainSlider provides superb access to the load deck, giving maximum flexibility in loading and unloading from three sides of the load area, whether it be fast access to the load from the sides using Fork Trucks, or load bay access via the rear doors. The sliding design of the curtains ensure the curtains 'pleat' efficiently when opened giving maximum access width to the load area, once unloaded any remaining load can be accessed by pulling the curtain to the other end of the body.

The standard aero-pack significantly reduces drag, improving journey times, fuel economy and driver fatigue. A range of useful optional equipment is available at extra cost to provide greater ease of use and protection, including a bespoke curtain colourway and screen printing service.

Available as a 4.0m internal bodylength and with a choice of 115PS, 140PS or 200PS Duratorq TDCi diesel engines, the Ford Transit Curtainside provides one of the finest distribution vehicles available.

Features include:

- 18mm resin bonded ply floor
- Translucent GRP Roof
- GRP overcab air dam and side streamers (frozen white only)
- Integral box section aluminium curtain stiffeners
- Roller bearing top runners
- Locking curtains and rear Doors
- 270 rear doors with retainers
- Powder coat aluminium rear door panels (frozen white only)
- Mid blue curtains fitted as standard, all cab colours optional colours available at extra cost

Optional bump strip helps reduce damage from Fork Trucks



Curtain retainers built into curtain lower runner



Lockable rear door handle with top and bottom latch



Telescopic rear door retainers hold doors safely in the 270° position. Brolly handle retainers rotate and stow under the load deck when not in use.

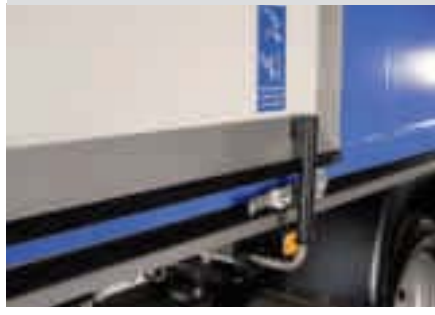

Standard nearside bulkhead mounted grab handle with optional side underrun guard step, tubular stirrup step fitted as standard



Interior 50W Halogen worklamp mounted on a ball and socket joint can be repositioned to suit lighting requirements



Optional flush fitting grab handles



Optional bulkhead load-loc rail and additional lath's, 6 fitted as standard



Flush fitting pull-up load anchorage points, 4 per side mounted discreetly into the curtain lower runner section





3.6 m/11ft 9in 350L.



4.0 m/13ft 1in 350EF.

Built to take everyday knocks, the ply / GRP panelled Box Van is robust enough to cope with the harsh use metered out in multi drop distribution, whilst still capable of carrying a competitive payload. The highly efficient aero-pack is now standard, reducing drag by 30%, improving fuel efficiency, journey times and driver fatigue.

The steel rear door frame has been designed for optional Tail-lift installation at the time of build, or as a retro-fit should the vehicles function change at a later date. A flat load floor with a generous rear aperture ensures the loadspace can be used to its maximum potential.

To help restrain the load an innovative load restraint system has been developed utilising telescopic load poles that can be positioned anywhere along the length of the body at four heights, this system in addition to the traditional ratchet straps gives maximum load restraint flexibility and safety.

A range of optional bodywork equipment provides true flexibility in specification can be specified to tailor the body to your requirements. To gain maximum access to the load area, a lightweight pillar tail-lift will provide convenient access for heavier loads.

With a choice of 115PS, 140PS or 200PS Duratorq TDCi diesel engines, a comfortable cab and a host of convenient features, including an easy-open rear shutter and translucent plastic roof, the Ford Transit Box Van makes perfect sense all-round.

One-Stop Box Van

Features include:

- 3.6m and 4.0m internal body lengths
- 15.5 cu.m and 17.2 cu.m loadspace
- Slam shut, lockable uPVC slat shutter
- Internal emergency rear door release
- 15mm phenolic resin-bonded one piece plywood floor
- Full-width aluminium rear step
- Internal side wall mounted load restraint rails
- 3 telescopic load retention poles supplied as standard
- Full height internal access grab handle
- Body finished in Frozen White only

Emergency internal rear door over-ride, allows rear shutter to be raised if inadvertently locked from the outside



Grab handle and step



Rear mounted internal halogen spot lamp with switch, adjustable to allow coverage inside and outside of the load area



Multi position, telescopic load retention poles



Wide slat rear shutter gives maximum internal headroom



Load anchorage points located in the lower rail



We are all beginning to understand the impact that mobility is having on climate change. While we can't change things overnight, we are working very hard to find solutions.

Making a difference now

Our latest range of engines complies with Euro Stage IV regulations. Duratorq TDCi diesel engines now develop more torque whilst delivering lower emissions. On Transit models, our Duratec 2.3L engine can be converted to run on liquefied petroleum gas (LPG) or compressed natural gas (CNG).

In the Ford car range, our optional Flexifuel engine is achieving emission reductions of around 30% to 80%** compared to conventional petrol engines.

Protecting the future

Using our Product Sustainability Index, a design for sustainability management tool, we are addressing the environmental, social and economic impacts of our vehicles from the earliest stages of their development*.

We are working on a wide range of vehicle technologies from biofuels to hybrids and clean diesels, and in the long term to hydrogen fuel-cell technology with the potential for near zero CO₂ emissions.

Improving our manufacturing facilities

We are constantly working to minimise the impact of our facilities on the environment. This includes pioneering on-site generation of electricity from sun and wind, implementing leading-edge manufacturing processes and full certification to the international standard for Environmental Management Systems; ISO 14001. This has led to improved environmental performance through savings in energy, water, material and waste-handling requirements.

Recycling for good

In the interests of sustainability, many of our components contain recycled and renewable content. All Ford vehicles are at least 85% recyclable and 95% recoverable in accordance with ISO 22628. We offer free take-back for qualifying vehicles at the end of their lives. All our take-back points are fully licensed and must also meet additional Ford quality standards for the professional receipt, treatment and recovery of end-of-life vehicles.

This brochure has been produced on paper based on fibres from sustainable forestry, using a 100% chlorine-free (TCF) bleaching process.

*For more about this topic, see <http://www.ford.com/en/company/about/sustainability/2006-07/downloads.htm>

**Dependent on feedstock used and production process. (Source: EUCAR CONCAWE study.) Ford supports the sustainable production of biofuels.



Programme for the Endorsement of Forest Certification schemes

This brochure is printed on PEFC certified paper promoting sustainable forest management.

Our range of finance, insurance, service and assistance options is designed with just one thing in mind – making life easy for you.

Ford Credit

Your Ford Transit Specialist Dealer can offer simple, plain language advice on the various ways of financing your purchase. They can help you complete an application and get a decision, usually within 15 minutes. For further details, visit www.ford.co.uk or contact your Ford Transit Specialist Dealer.

Ford Acquire is a straightforward way to own your vehicle. Simply put down a deposit, pay the remainder, plus interest, over an agreed period and the vehicle becomes yours.

Ford Business Partner Contract Hire* provides an affordable, convenient and flexible way to finance your business vehicle.

Ford Insure* is our comprehensive motor insurance product, designed specifically for Ford drivers.

Finance subject to status. **Business Users only.** Guarantees/Indemnities may be required. Freepost Ford Credit.

*Business Partner Contract Hire is provided by Lex Vehicle Leasing Limited, trading as Ford Business Partner, Heathside Park, Heathside Park Road, Stockport SK3 0RB.

*Ford Insure is underwritten and administered by Royal & Sun Alliance Insurance plc (No. 93792), Registered in England and Wales at St. Mark's Court, Chart Way, Horsham, West Sussex, RH12 1XL. Authorised and regulated by the Financial Services Authority. For your protection, telephone calls may be recorded and monitored.

Services

There are 222 Sales and 245 Aftersales Ford Transit Specialist Dealers across the UK, equipped and trained to meet Commercial Vehicle customer requirements. From these, 113 Sales and 95 Aftersales Dealers have achieved the 'Backbone standard' as recognition of their total commitment to delivering dedicated and professional sales and service support.

To find the location of your nearest Ford Transit Specialist Dealer, simply call the Ford Information Service on **0845 7111 888**, or visit the Ford Dealer locator at www.fordvans.co.uk

Ford Protect Every new Ford Fiesta Van is protected by a 3-year/60,000-mile Ford Protect Classic Warranty Plan, and also comes with a 1-year Ford Assistance package.

Ford Ranger is protected by a 3-year/60,000 mile Ford Protect Classic Warranty Plan

Ford Transit and Transit Connects are protected by a 3-year/100,000-mile bumper-to-bumper warranty.

Ford Transit Chassis Cab One-Stop bodywork is covered by a 3-year/100,000-mile warranty and a 3-year Perforation Warranty provided by the bodywork supplier.

Ford Perforation Warranty Every new Ford Fiesta Van, Transit and Transit Connect is covered by the Ford Perforation Warranty for 8 years⁹ from the date of first registration. Ranger is covered for 6 years from the date of first registration.

Ford Assistance Ford Transits, Transit Connects and Rangers are supplied with a minimum of a 1-year Ford Assistance roadside package. Further details are available either on www.ford.co.uk or from your local Ford Dealer.

Ford Rapid Fit Our 'no appointments necessary, while-you-wait' fast-fit service for exhausts, brakes, batteries and more, at over 240 sites nationally.

Ford Accident Repair Centres Approved Ford Accident Repair Centres meet rigorous Ford standards and are the best place to return your vehicle to its pre-accident condition.

Contacts

Ford Customer Relationship Centre In the unlikely event that your Ford Dealer can't help you or if you need to speak to us directly, call 0845 841 1111 at local rates.

Ford Rental – local service nationwide Car and van rental from our latest model range. Contact your local Ford Dealer for more information.

Talkback – the company car drivers' club This is your club for extended test drives, special events, and advice on tax and buying issues. Join free, even if you don't drive a Ford, on www.talkbackclub.com or call 0845 605 55 66.

Ford Mobility Our MAGIC care centre provides free information on all motoring and mobility issues, including special offers for HRDLA and Motability recipients. Call free on 0800 240 241.

⁹Subject to terms and conditions.

Ford range

Ford Transit Minibus

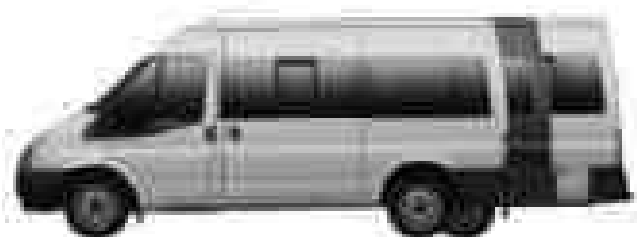

Ford Tourneo



Ford Tourneo Connect



	Seats	Wheelbase	Overall length (mm)	Overall height (mm)	Overall width (mm) [†]
Ford Tourneo Connect	5 and 8	LWB	4525	1981	2044
Ford Tourneo	8 and 9	SWB	4863	1989-2070	2374
Ford Transit Minibus	9 and 12	MWB	5230	2302-2363	2374
	15	LWB	5680	2393	2374
	17	LWB EL	6403	2380	2374
	17 High Roof	LWB EL	6403	2624	2374

[†]Includes mirrors.

Ford Transit Chassis Cab

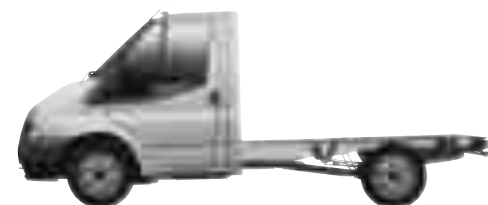

Ford Transit Chassis Double Cab

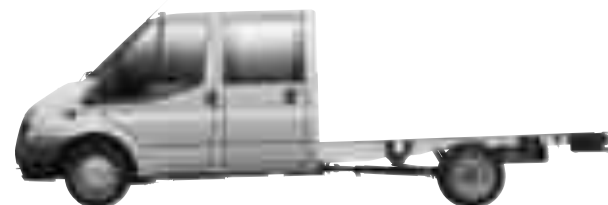

	Nominal body length	Wheelbase	Payload (gross)** (kg)	Gross Vehicle Mass (kg)	Maximum Gross Train Mass (kg)
Ford Chassis Cab	2.85m (9ft 4in)	SWB	1323-1444	3000	3500-5000
	3.2m (10ft 6in)	MWB	1584-2724	3500-4600	6000-6500
	3.66m (12ft 0in)	LWB	1578-2673	3500-4600	6000-6500
	4.0m (13ft 1in)	LWB EF	1530-2669	3500-4600	6000-6500
Ford Chassis Double Cab	2.85m (9ft 4in)	LWB	1457-2596	3500-4600	6000-6500
	3.2m (10ft 6in)	LWB EF	1450-2588	3500-4600	6000-6500

**Gross payload = GVM minus kerbweight.

Ford Transit Van



Ford Transit Double Cab-in-Van



Ford Transit Connect Van



Ford Fiesta Van



	Wheelbase	Load length (mm)	Cube (cu.m)	Payload (gross)** (kg)	Gross Vehicle Mass (kg)	Maximum Gross Train Mass (kg)
Ford Fiesta Van	SWB	1320	1.013	507-515	1490-1550	1190-2300
Ford Fiesta SportVan	SWB	1320	1.013	515	1550	2300
Ford Transit Connect Van	SWB	1760 [‡] -2467 ^{‡‡}	2.8 [‡] -3.4 ^{‡‡}	625-825	2040-2240	2840-3040
	LWB	2007 [‡] -2714 ^{‡‡}	3.7 [‡] -4.3 ^{‡‡}	900	2340	3140
Ford Transit Connect Crew van	SWB	909	1.4	733	2240	3040
	LWB	1172	2.1	772	2340	3140
Ford Transit Van	SWB	2582	6.55-7.94	864-1555	2600-3300	3500-5300
	MWB	2949	7.44-10.31	964-1677	2800-3500	3500-6300
	LWB	3399	9.85-11.89	940-1586	3000-3500	4500-6300
	LWB EL 'Jumbo'	4107	14.30	1146-2265	3500-4600	5500-6500
Ford Transit Double Cab-in-Van	SWB	1654	4.20-5.20	756-1000	2600-2800	3500
	MWB	1893	4.80-6.80	856-1399	2800-3500	3500-6300
	LWB	2349* -2506**	7.10-8.50	832-1372	3000-3500	4500-6300
	LWB EL 'Jumbo'	3229	10.80	1099-1210	3500-4600	5500-6500

**Gross payload = GVM minus kerbweight. [‡] With passenger's seat upright, ^{‡‡} With passenger seat folded. *FWD **RWD

Ford Ranger

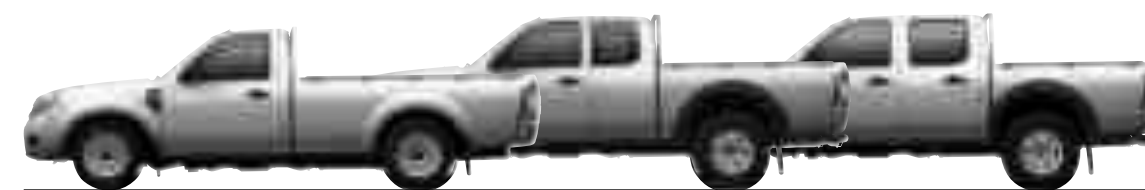

	Drive	Load box length (mm)	Load box width (mm)	Payload (gross)** (kg)	Gross Vehicle Mass (kg)	Maximum Gross Train Mass (kg)
Ford Ranger Regular Cab	4x2/4x4	2280	1456	1190/1235	2800/3010	4400/6010
Ford Ranger Super Cab	4x2/4x4	1753	1456	1225/1225	2885/2995	4485/5995
Ford Ranger Double Cab	4x4	1530	1456	1175	2995	5995

**Gross payload = GVM minus kerbweight.

Ford Transit Chassis Cab SWB

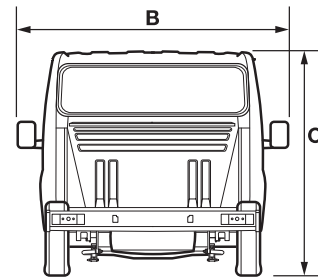
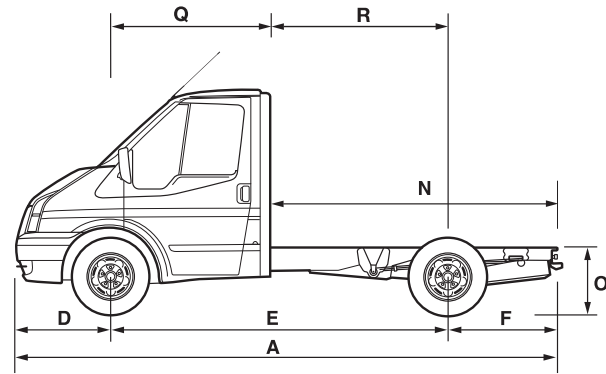

Dimensions (mm)

	SWB Chassis Cab Rear Wheel Drive	SWB Chassis Cab Front Wheel Drive
A Overall length	5118	5118
B Overall width across – mirrors – cab – rear tyres	2374 1974 1945	2374 1974 1930
C Overall height*	2032 -2035	1974-2030
D Front overhang	933	933
E Wheelbase	3137	3137
F Rear overhang (including rear light crossmember)	1048	1048
N Chassis frame length (not including rear light crossmember)	2679	2679
O Chassis frame height, end of frame*	748 -751	666 -735
Q Front axle to back of cab	1406	1406
R Back of cab to rear axle	1731	1731
Turning circle (m)		
Kerb to kerb	11.4	11.4
Wall to wall	12.1	12.1

Key: All dimensions (shown in mm) are subject to manufacturing tolerances and refer to minimum specification models and do not include additional equipment.
*Height dimensions show the range from minimum to maximum of a fully laden, lowest payload vehicle to unladen highest payload vehicle. These illustrations are for guidance only.

Weights and loads

	Driveline	GVM (kg)	Kerb mass* (kg)	Payload (gross) (kg) ⁹	Front axle plated mass (kg)	Rear axle plated mass (kg)	Front axle kerb mass (kg)	Rear axle kerb mass (kg)	Axle ratio ¹⁰	Max. GTM (kg)
300S Chassis Cab SRW										
2.2 TDCi 115 PS	FWD	3000	1556	1444	1600	1760	1133	423	4.36	3500
2.2 TDCi 140 PS	FWD	3000	1559	1441	1600	1760	1135	424	4.36	3500
2.4 TDCi 100PS	RWD	3000	1677	1323	1600	1850	1141	536	5.11	5000

S = Short wheelbase. **SRW** = Single rear wheels. **FWD** = Front-wheel Drive. **GVM** = Gross vehicle mass. The total permissible all-up weight of a rigid vehicle – i.e. with body, payload, ancillaries, fuel, oil, water, driver and crew. **GTM** = Gross train mass. The total permissible all-up weight of a rigid vehicle (see GVM) together with its trailer and load. Maximum gross trailer mass (braked) 2000kg. For FWD models, gross trailer capacity may be less than 2000kg dependent upon the kerb weight of the chassis, body and any payload present. Full prime mover GVM may not be attainable when trailer capacity at maximum on certain driveline combinations. The optional digital tachograph may be required under UK, EC or AETR law, reference:- Drivers Hours and Tachograph rules for Goods Vehicles in the UK or Europe. ⁹**Gross Payload** = Gross vehicle mass, less kerb mass. ^{*}**Kerb mass** = The weight of the complete vehicle and all equipment including spare wheel, fuel and water, but without payload, bodywork, driver or any crew. All kerb masses quoted in this brochure are subject to manufacturing tolerances and are for vehicles with minimum equipment. **Axle Ratio** = ¹⁰The rear axle ratio shown is recommended for most applications, alternative ratios with reduced GTM are available (RWD only) for more specialised applications, please consult your Ford Dealer for details.

Ford Transit Chassis Cab MWB

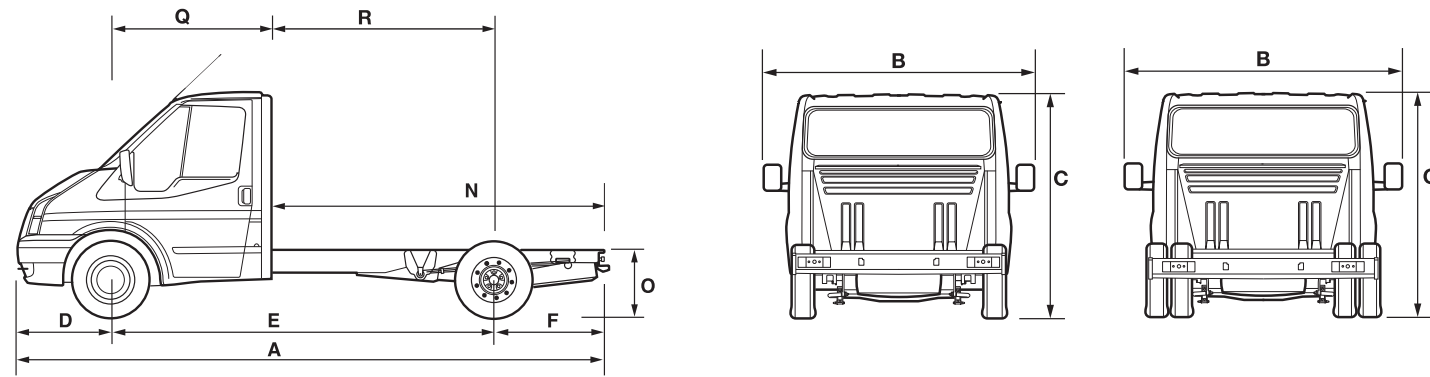

Dimensions (mm)

	MWB Chassis Cab Rear Wheel Drive
A Overall length – 4cyl/5cyl	5485/5556
B Overall width across	2492
– mirrors	1974
– cab	2052
– standard DRW 185 section rear tyres	1967
– optional SRW 215 section rear tyres	2068
C Overall height*	2023-2035
D Front overhang – 4cyl/5cyl	933/1004
E Wheelbase	3504
F Rear overhang (including rear light crossmember)	1048
N Chassis frame length (not including rear light crossmember)	3148
O Chassis frame height, end of frame* – 350/460 & HD350	741-762/793-814
Q Front axle to back of cab	1406
R Back of cab to rear axle	2098
Turning circle (m)	
Kerb to kerb	12.5
Wall to wall	13.1

Key: All dimensions (shown in mm) are subject to manufacturing tolerances and refer to minimum specification models and do not include additional equipment.
*Height dimensions show the range from minimum to maximum of a fully laden, lowest payload vehicle to unladen highest payload vehicle. These illustrations are for guidance only.

Weights and loads

	Driveline	GVM (kg)	Kerb mass* (kg)	Payload (gross) (kg) ⁹	Front axle plated mass* (kg)	Rear axle plated mass (kg)	Front axle kerb mass (kg)	Rear axle kerb mass (kg)	Axle ratio ⁹⁹	Max. GTM (kg)
350M Chassis Cab DRW										
2.4 TDCi 100 PS	RWD	3500	1774	1726	1750	2450	1188	586	5.11	6000
2.4 TDCi 115 PS	RWD	3500	1788	1712	1750	2450	1200	588	4.27	6000
2.4 TDCi 140 PS	RWD	3500	1807	1693	1750	2450	1203	604	4.27	6300
3.2 TDCi 200 PS	RWD	3500	1884	1616	1750	2450	1273	611	4.10	6300
350M Chassis Cab SRW										
2.4 TDCi 100 PS	RWD	3500	1729	1771	1750	2250	1177	552	5.11	6000
2.4 TDCi 115 PS	RWD	3500	1744	1756	1750	2250	1190	554	4.27	6000
2.4 TDCi 140 PS	RWD	3500	1763	1737	1750	2250	1193	570	4.27	6300
2.4 TDCi 140 PS	AWD	3500	1844	1656	1750	2250	1264	580	4.27	6300
3.2 TDCi 200 PS	RWD	3500	1840	1660	1750	2250	1263	577	4.10	6300
350M HD (Heavy Duty) Chassis Cab DRW										
2.4 TDCi 140 PS	RWD	3500	1840	1660	1850	2600	1221	619	4.27	6500
3.2 TDCi 200 PS	RWD	3500	1916	1584	1850	2600	1291	625	4.10	6500
460M Chassis Cab DRW										
2.4 TDCi 140 PS	RWD	4600	1876	2724	1850	3300	1245	631	4.27	6500
3.2 TDCi 200 PS	RWD	4600	1954	2646	1850	3300	1316	638	4.10	6500

M = Medium wheelbase. **SRW** = Single rear wheels. **DRW** = Double rear wheels. **FWD** = Front-wheel Drive. **RWD** = Rear-wheel Drive. **GVM** = Gross vehicle mass. The total permissible all-up weight of a rigid vehicle – i.e. with body, payload, ancillaries, fuel, oil, water, driver and crew. **GTM** = Gross train mass. The total permissible all-up weight of a rigid vehicle (see GVM) together with its trailer and load. Maximum gross trailer mass (braked) 2800kg. Gross trailer capacity may be less than 2800kg dependent upon driveline or kerb weight of the chassis, body and any payload present. Full prime mover GVM may not be attainable when trailer capacity at maximum on FWD models including certain RWD driveline combinations. The optional digital tachograph may be required under UK, EC or AETR law, reference:- Drivers Hours and Tachograph rules for Goods Vehicles in the UK or Europe. ⁹**Gross Payload** = Gross vehicle mass, less kerb mass. ***Kerb mass** = The weight of the complete vehicle and all equipment including spare wheel, fuel oil and water, but without payload, bodywork, driver or any crew. All kerb masses quoted in this brochure are subject to manufacturing tolerances and for vehicles with minimum equipment. ⁹⁹**Axle Ratio** = The rear axle ratio shown is recommended for most applications, alternative ratios with reduced GTM are available for more specialised applications. Please consult your Ford Dealer for details. ***Front axle kerb mass** = Optional 1850 kg front axle available on all RWD variants, 20kg kerbweight increase.

Ford Transit Chassis Cab LWB

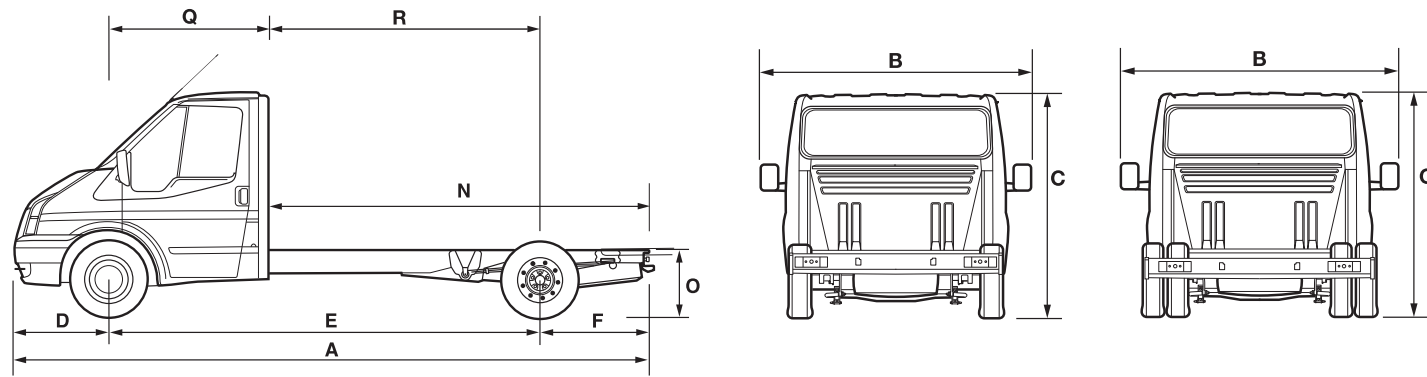

Ford Transit Chassis Double Cab LWB

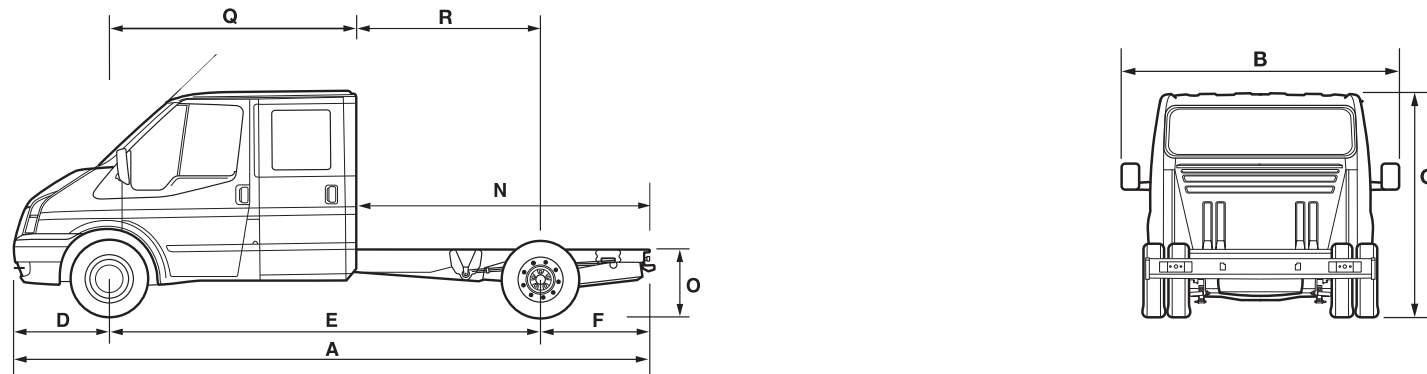

Dimensions (mm)

	LWB Chassis Cab Rear Wheel Drive	LWB Chassis Double Cab Rear Wheel Drive
A Overall length – 4cyl/5cyl	5935/6006	5935/6006
B Overall width across		
– mirrors	2492	2492
– cab	1974	1974
– standard DRW 185 section rear tyres	2052	2052
– optional SRW 215 section tyres	1967	1967
– standard DRW 195 section rear tyres – 460, HD350 or regular 350 with optional 1850Kg front axle	2068	2068
C Overall height*	2018-2031	2016-2031
D Front overhang – 4cyl/5cyl	933/1004	933/1004
E Wheelbase	3954	3954
F Rear overhang (including rear light crossmember)	1048	1048
N Chassis frame length (not including rear light crossmember)	3496	2679
O Chassis frame height, end of frame* – 350/460 & HD350	733-748/785-800	736-748/788-800
Q Front axle to back of cab	1406	2223
R Back of cab to rear axle	2548	1731
Turning circle (m)		
Kerb to kerb	13.9	13.9
Wall to wall	14.5	14.5

Key: All dimensions (shown in mm) are subject to manufacturing tolerances and refer to minimum specification models and do not include additional equipment.
*Height dimensions show the range from minimum to maximum of a fully laden, lowest payload vehicle to unladen highest payload vehicle. These illustrations are for guidance only.

Weights and loads

	Driveline	GVM (kg)	Kerb mass* (kg)	Payload (gross) (kg) ^o	Front axle plated mass* (kg)	Rear axle plated mass (kg)	Front axle kerb mass (kg)	Rear axle kerb mass (kg)	Axle ratio ^{oo}	Max. GTM (kg)
350L Chassis Cab DRW										
2.4 TDCi 100 PS	RWD	3500	1812	1688	1750	2450	1217	595	5.11	6000
2.4 TDCi 115 PS	RWD	3500	1827	1673	1750	2450	1230	597	4.27	6000
2.4 TDCi 140 PS	RWD	3500	1847	1653	1750	2450	1233	614	4.27	6300
3.2 TDCi 200 PS	RWD	3500	1922	1578	1750	2450	1302	620	4.10	6300
350L Chassis Cab SRW										
2.4 TDCi 100 PS	FWD	3500	1769	1731	1750	2250	1215	554	4.93	6000
2.4 TDCi 115 PS	RWD	3500	1784	1716	1750	2250	1228	556	5.11	6000
2.4 TDCi 140 PS	RWD	3500	1804	1696	1750	2250	1231	573	4.27	6300
3.2 TDCi 200 PS	RWD	3500	1880	1620	1750	2250	1300	580	4.10	6300
350HD (Heavy Duty) LWB Chassis Cab DRW										
2.4 TDCi 140 PS	RWD	3500	1889	1611	1850	2600	1244	645	4.27	6500
460 LWB Chassis Cab DRW										
2.4 TDCi 140 PS	RWD	4600	1927	2673	1850	3300	1269	658	4.27	6500
350L Double Cab DRW										
2.4 TDCi 100 PS	RWD	3500	1889	1611	1750	2450	1266	623	5.11	6000
2.4 TDCi 115 PS	RWD	3500	1903	1597	1750	2450	1278	625	4.27	6000
2.4 TDCi 140 PS	RWD	3500	1923	1577	1750	2450	1281	642	4.27	6300
3.2 TDCi 200 PS	RWD	3500	2000	1500	1750	2450	1351	649	4.10	6300
350HD (Heavy Duty) LWB Double Cab DRW										
2.4 TDCi 140 PS	RWD	3500	1966	1534	1850	2600	1293	673	4.27	6500
3.2 TDCi 200 PS	RWD	3500	2043	1457	1850	2600	1363	680	4.10	6500
460 LWB Double Cab DRW										
2.4 TDCi 140 PS	RWD	4600	2004	2596	1850	3300	1318	686	4.27	6500
3.2 TDCi 200 PS	RWD	4600	2083	2517	1850	3300	1390	693	4.10	6500

L = Long wheelbase. **SRW** = Single rear wheels. **DRW** = Double rear wheels. **FWD** = Front-wheel Drive. **RWD** = Rear-wheel Drive. **GVM** = Gross vehicle mass. The total permissible all-up weight of a rigid vehicle – i.e. with body, payload, ancillaries, fuel, oil, water, driver and crew. **GTM** = Gross train mass. The total permissible all-up weight of a rigid vehicle (see GVM) together with its trailer and load. Maximum gross trailer mass (braked) 2800kg. Gross trailer capacity may be less than 2800kg dependent upon driveline or kerb weight of the chassis, body and any payload present. Full prime mover GVM may not be attainable when trailer capacity at maximum on FWD models including certain RWD driveline combinations. The optional digital tachograph may be required under UK, EC or AETR law, reference:- Drivers Hours and Tachograph rules for Goods Vehicles in the UK or Europe. ^o**Gross Payload** = Gross vehicle mass, less kerb mass. ^{*}**Kerb mass** = The weight of the complete vehicle and all equipment including spare wheel, fuel, oil and water, but without payload, bodywork, driver or any crew. All kerb masses quoted in this brochure are subject to manufacturing tolerances and are for vehicles with minimum equipment. ^{oo}**Axle ratio** = The rear axle ratio shown is recommended for most applications, alternative ratios with reduced GTM are available for more specialised applications, please consult your Ford Dealer for details. ^{*}**Front axle kerb mass** = Optional 1850kg front axle available on all RWD variants, 20kg kerbweight increase.

Ford Transit Chassis Cab LWB Extended Frame

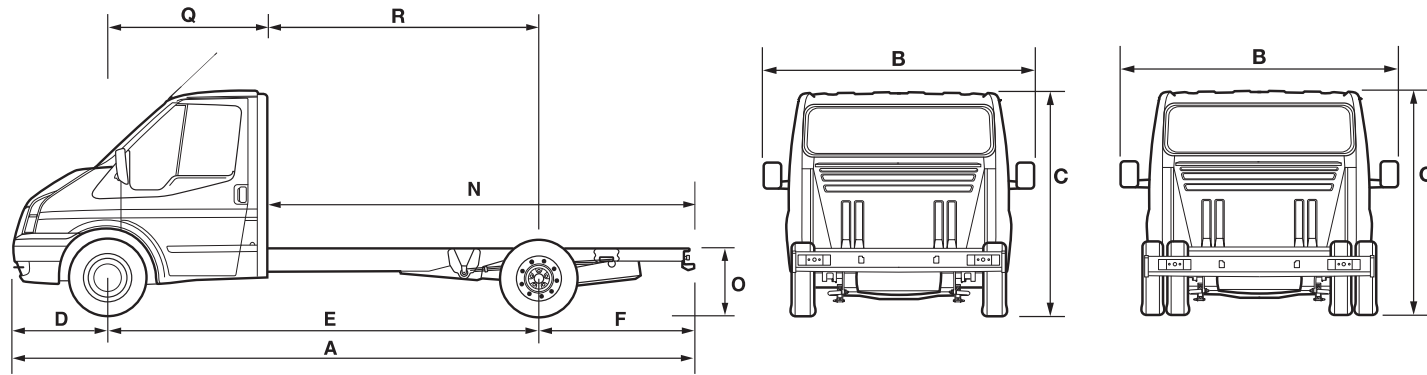

Ford Transit Chassis Double Cab LWB Extended Frame

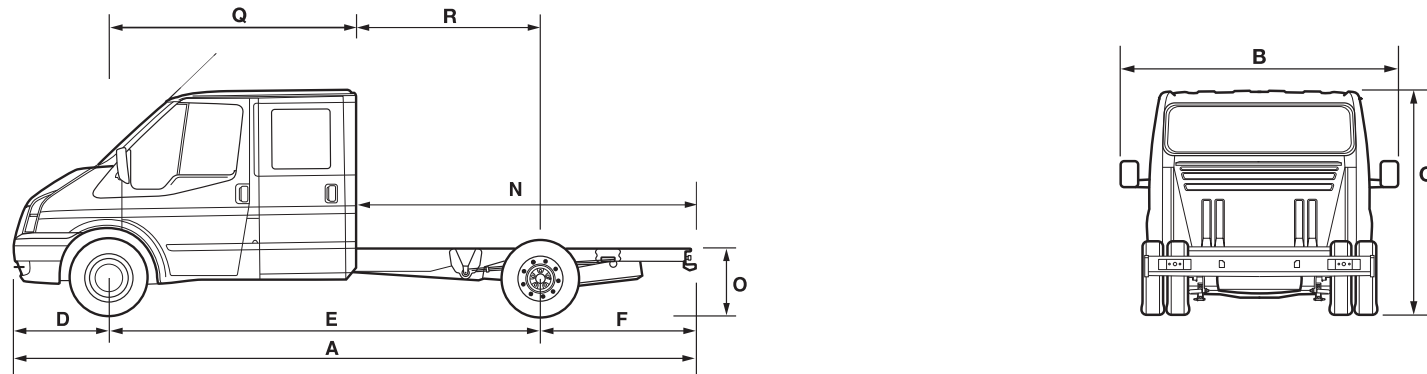

Dimensions (mm)

	LWB EF Chassis Cab Rear Wheel Drive	LWB EF Chassis Double Cab Rear Wheel Drive
A Overall length – 4cyl/5cyl	6317/6388	6317/6388
B Overall width across		
– mirrors	2492	2492
– cab	1974	1974
– standard DRW 185 section rear tyres	2052	2052
– optional SRW 215 section tyres	1967	1967
– standard DRW 195 section rear tyres - 460, HD350 or regular 350 with optional 1850Kg front axle	2068	2068
C Overall height*	2015-2030	2015-2030
D Front overhang – 4cyl/5cyl	933/1004	933/1004
E Wheelbase	3954	3954
F Rear overhang (including rear light crossmember)	1430	1430
N Chassis frame length (not including rear light crossmember)	3980	3060
O Chassis frame height, end of frame* – 350/460 & HD350	733-748/785-800	733-748/785-800
Q Front axle to back of cab	1406	2223
R Back of cab to rear axle	2548	1731
Turning circle (m)		
Kerb to kerb	13.9	13.9
Wall to wall	14.5	14.5

Key: All dimensions (shown in mm) are subject to manufacturing tolerances and refer to minimum specification models and do not include additional equipment.
*Height dimensions show the range from minimum to maximum of a fully laden, lowest payload vehicle to unladen highest payload vehicle. These illustrations are for guidance only.

Weights and loads

	Driveline	GVM (kg)	Kerb mass* (kg)	Payload (gross) (kg) ^o	Front axle plated mass (kg)	Rear axle plated mass (kg)	Front axle kerb mass* (kg)	Rear axle kerb mass (kg)	Axle ratio ^{oo}	Max. GTM (kg)
350EF Chassis Cab DRW										
2.4 TDCi 100 PS	RWD	3500	1827	1673	1750	2450	1209	618	5.11	6000
2.4 TDCi 115 PS	RWD	3500	1842	1658	1750	2450	1222	620	4.27	6000
2.4 TDCi 140 PS	RWD	3500	1862	1638	1750	2450	1225	637	4.27	6300
3.2 TDCi 200 PS	RWD	3500	1939	1561	1750	2450	1295	644	4.10	6300
350EF Chassis Cab SRW										
2.4 TDCi 100 PS	RWD	3500	1785	1715	1750	2300	1207	578	5.11	6000
2.4 TDCi 115 PS	RWD	3500	1800	1700	1750	2300	1220	580	4.27	6000
2.4 TDCi 140 PS	RWD	3500	1819	1681	1750	2300	1223	596	4.27	6300
3.2 TDCi 200 PS	RWD	3500	1896	1604	1750	2300	1293	603	4.10	6300
350EF HD (Heavy Duty) Chassis Cab DRW										
2.4 TDCi 140 PS	RWD	3500	1893	1607	1850	2600	1236	657	4.27	6500
3.2 TDCi 200 PS	RWD	3500	1970	1530	1850	2600	1306	664	4.10	6500
460EF Chassis Cab DRW										
2.4 TDCi 140 PS	RWD	4600	1931	2669	1850	3300	1261	670	4.27	6500
3.2 TDCi 200 PS	RWD	4600	2009	2591	1850	3300	1332	677	4.10	6500
350EF Double Cab DRW										
2.4 TDCi 100 PS	RWD	3500	1908	1592	1750	2450	1258	650	5.11	6000
2.4 TDCi 115 PS	RWD	3500	1921	1579	1750	2450	1270	651	4.27	6000
2.4 TDCi 140 PS	RWD	3500	1941	1559	1750	2450	1273	668	4.27	6300
3.2 TDCi 200 PS	RWD	3500	2018	1482	1750	2450	1343	675	4.10	6300
350EF HD (Heavy Duty) Double Cab DRW										
2.4 TDCi 140 PS	RWD	3500	1973	1527	1850	2600	1285	688	4.27	6500
3.2 TDCi 200 PS	RWD	3500	2050	1450	1850	2600	1355	695	4.10	6500
460EF Double Cab DRW										
2.4 TDCi 140 PS	RWD	4600	2012	2588	1850	3300	1310	702	4.27	6500
3.2 TDCi 200 PS	RWD	4600	2091	2509	1850	3300	1327	764	4.10	6500

EF = Long wheelbase, extended frame. **SRW** = Single rear wheels. **DRW** = Double rear wheels. **FWD** = Front-wheel Drive. **RWD** = Rear-wheel Drive. **GVM** = Gross vehicle mass. The total permissible all-up weight of a rigid vehicle – i.e. with body, payload, ancillaries, fuel, oil, water, driver and crew. **GTM** = Gross train mass. The total permissible all-up weight of a rigid vehicle (see GVM) together with its trailer and load. Maximum gross trailer mass (braked) 2800kg. Gross trailer capacity may be less than 2800kg dependent upon driveline or kerb weight of the chassis, body and any payload present. Full prime mover GVM may not be attainable when trailer capacity at maximum on FWD models including certain RWD driveline combinations. The optional digital tachograph may be required under UK, EC or AETR law, reference:- Drivers Hours and Tachograph rules for Goods Vehicles in the UK or Europe. ^o**Gross Payload** = Gross vehicle mass, less kerb mass. ^{*}**Kerb mass** = The weight of the complete vehicle and all equipment including spare wheel, fuel, oil and water, but without payload, bodywork, driver or any crew. All kerb masses quoted in this brochure are subject to manufacturing tolerances and are for vehicles with minimum equipment. ^{oo}**Axle Ratio** = The rear axle ratio shown is recommended for most applications, alternative ratios with reduced GTM are available for more specialised applications, please consult your Ford Dealer for details. ^{*}**Front axle kerb mass** = Optional 1850kg front axle available on all RWD variants, 20 kg kerbweight increase.

1-way Tipper 350M 3.2m/10ft 6in

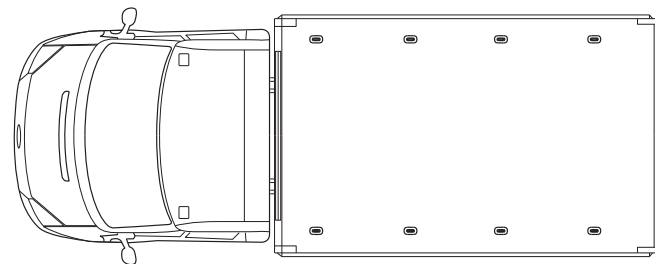
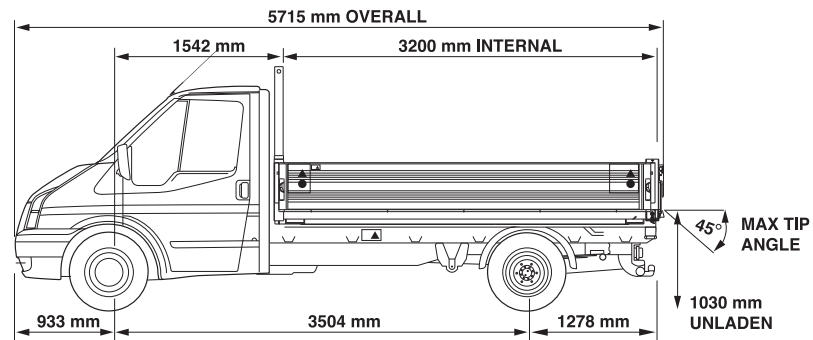

1-way Tipper 350L Double Cab 2.85m, 9ft 4in

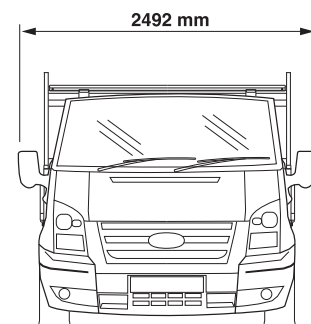
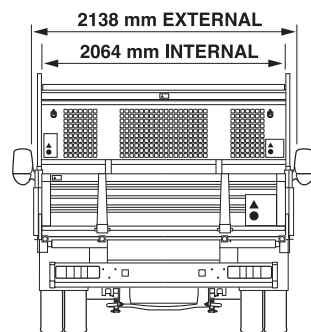
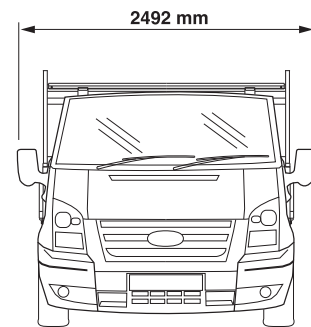
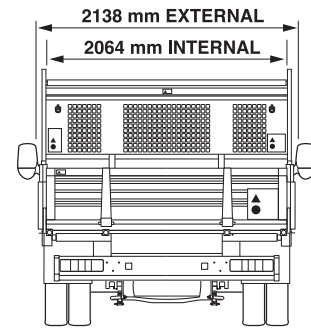
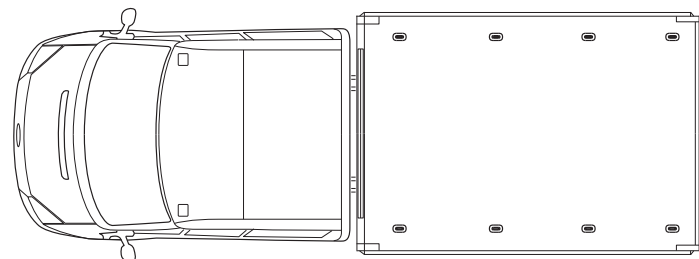
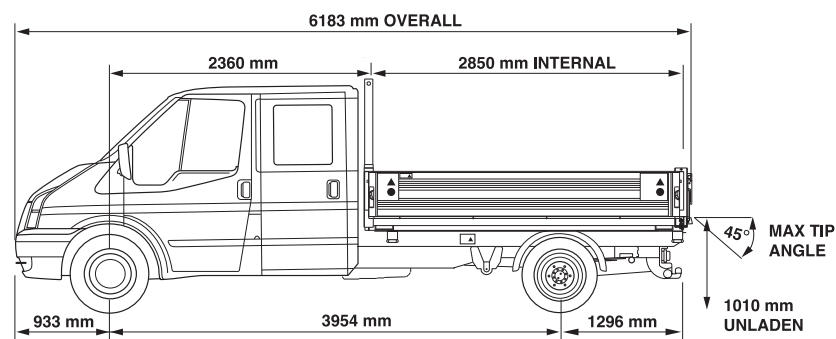

Weights and loads

	Rear axle ratio	350M Chassis Cab	350L Double Cab	HD350M Chassis Cab	HD350L Double Cab	460M Chassis cab	460L Double Cab
Plated weights (kg)							
FAM (Front Axle Mass)		1750	1750	1850	1850	1850	1850
FAM – Optional		1850	1850	–	–	–	–
RAM (Rear Axle Mass)		2450	2450	2600	2600	3300	3300
GVM		3500	3500	3500	3500	4600	4600
GTM 100PS (2.4L)	5.11	6000	6000	–	–	–	–
GTM 115PS (2.4L)	4.27	6000	6000	–	–	–	–
GTM 140PS (2.4L)	4.27	6300	6300	6500	6500	6500	6500
GTM 200PS (3.2L)	4.10	6300	6300	–	–	6500	6500
Payload							
100PS*		1148	1025	–	–	–	–
115/140PS*		1123	1000	995	879	2059	1979
200PS*		1110	982	–	–	1981	1902

*Payloads quoted are gross (full tank of fuel and fluids, no driver) and for minimum specification, optional chassis equipment including 1850kg front axle and optional body equipment will reduce payload allowance. Subject to manufacturing tolerance. **FAM** = Front axle plated mass. **RAM** = Rear axle plated mass. **GVM** = Gross vehicle mass. **GTM** = Gross train mass. Drawings are representative and may be subject to change.

Specifications

	Chassis Cab	Double Cab
Chassis		
Engine availability – Refer to chart (page 54)		
Transmission – 100 PS – 5 speed MT75	●	●
Transmission – 115/140/200PS – 6 speed MT82	●	●
Tyres – 185/75 R16C 104/102	●	●
Tyres – 195/75 R16C 107/105 (optional 1850kg Front Axle only) Std on HD350 & 460	○	○
Suspension – Front: Coil spring MacPherson strut, anti-roll bar	●	●
Suspension – Rear: Taper leaf + helper, anti-roll bar	●	●
Seating (Single Cab) – Driver's seat and dual passenger seat, lap and diagonal seat belts to all seats	●	
Seating (Double Cab) – 6-seat standard (driver, dual passenger, 3 seat bench in crew compartment)		●
Seating (Double Cab) – 7 seat, 4 seat rear bench with underseat stowage, lap and diagonal to outer seats, lap only to middle seats		○
Glazing – Laminated clear windscreen, toughened clear side and rear cab glass, tinted optional	●	●
Doors (Double Cab) – 4-door configuration with glazed rear doors		●
Electrical – Battery: 2 x 12V 590CCA (60Ah @ 20 hr rate), Alternator 150A	●	●
Cold start (-29°C) includes twin 680 CCA (70Ah @ 20h rate) batteries	○	○
Tow Bar (RPO), 50mm ball hitch, 13 pin socket and Tailboard protection plate. Note: A Tailboard protection plate must be fitted to the tailboard if a Ford Accessory tow bar kit or aftermarket tow bar kit is installed.	○	○
Body		
Type – 1-way, manual top and bottom hinged tailboard, bottom hinged sideboards	●	●
Ram – Centre 5-stage chrome-plated	●	●
Power Pack – 2 kW electro-hydraulic, mounted between subframe. 7lt oil capacity SAE10W-30W (ISO32)	●	●
Tip Angle – Electrically-limited to 45 degrees to the rear by limit switch operating on ram	●	●

Specifications

	Chassis Cab	Double Cab
Electrical System – 12V system, 150A fuse, subframe-mounted isolation switch, emergency stop switch	●	●
Subframe – Hot-dip galvanised steel (powder-coated), 'C' section with cruciform	●	●
Load Bed – Hot-dip galvanised powder-coated 2.5 mm steel, box section crossbearers, roll formed edge to rear aperture	●	●
Headboard – Removable full-width, full-height. Perforated behind cab rear window. Rubber-finished top surface (ladder gantry)	●	●
Front and Rear Pillars – Replaceable powder-coated steel over centre pull-up latches	●	●
Sideboards – Body-coloured double-skin aluminium, Steel on HD350 & 460	●	●
Tailboard – Top and bottom hinged, double skin aluminium, Steel on HD350 & 460	●	●
Fenders – Flexible thermoplastic, mounted on replaceable bolt-on fender brackets to subframe	●	●
Finish – Load bed, subframe and headboard – Slate grey powder-coat. Side and tailboards – Body colour, White: powder coated, all other colours 2-pack paint, cylinder casing: zinc passivated.	●	●
Load Lashing – 8 floor-mounted pull-up anchors (250 kg each), (6 on MWB D/Cab)	●	●
Roping hooks – 14 (S/Cab) 12 (LWB D/Cab) 10 (MWB D/Cab) side mounted, 4 rear, 2 forward face of headboard	●	●
Body Prop – Integral subframe mounted	●	●
Body Warranty – 3-year, 100,000 miles.	●	●
Certification		
CE certified	●	●
EMC certified 72/245/EEC, 95/54/EC	●	●
TUV Certified 98/37/CE Machine directive – Safety requirements	●	●

● = Standard, ○ = Option, at extra cost. 350HD and 460 derivatives not available. Drawings are representative and may be subject to change.

3-way Tipper 350M 3.2m/10ft 6in

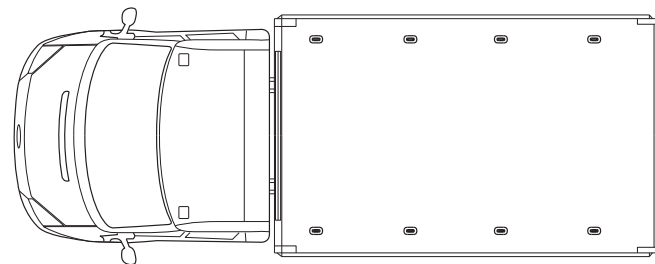
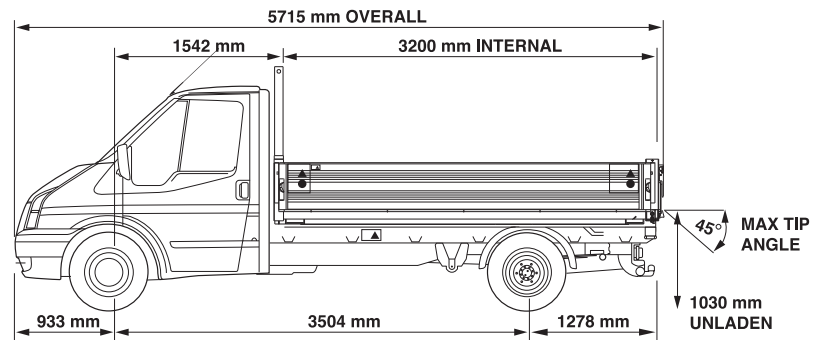

3-way Tipper 350L Double Cab 2.85m, 9ft 4in

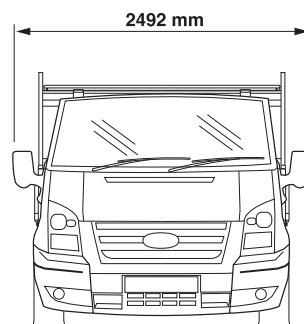
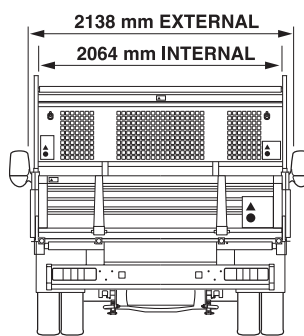
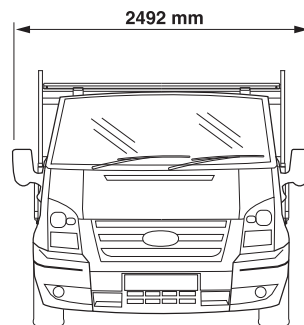
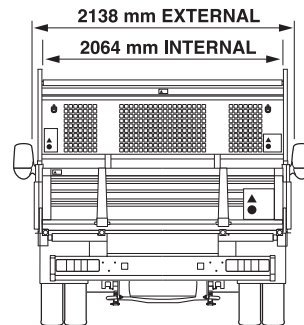
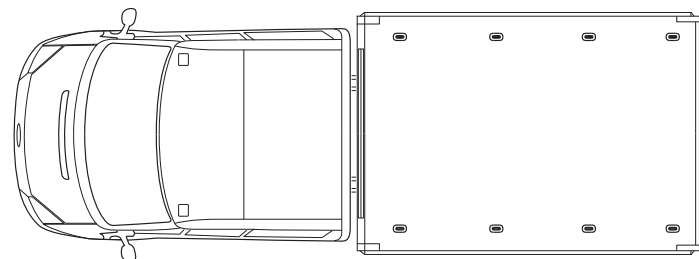
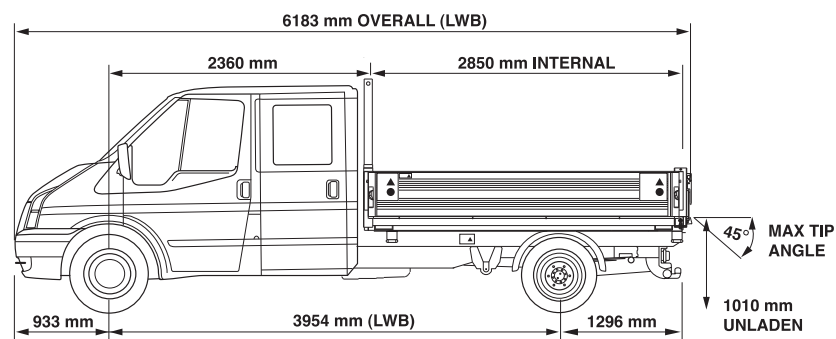

Weights and loads

	Rear axle ratio	350M Single Cab	350L Double Cab	HD350M Chassis Cab	HD350L Double Cab	460M Single Cab	460L Double Cab
Plated weights (kg)							
Front Axle		1750	1750	1850	1850	1850	1850
Front Axle – Optional		1850	1850	–	–	–	–
Rear Axle		2450	2450	2600	2600	3300	3300
GVM		3500	3500	3500	3500	4600	4600
GTM 115PS (2.4L)	4.27	6000	6000	–	–	–	–
GTM 140PS (2.4L)	4.27	6300	6300	6500	6500	6500	6500
GTM 200PS (3.2L)	4.10	6300	6300	–	–	6500	6500
Payload (kg)							
115 & 140 PS*		1046	928	925	886	1989	1871
200PS*		969	851	–	–	1911	1792

*Payloads quoted are gross (full tank of fuel and fluids, no driver) and for minimum specification, optional chassis equipment including 1850kg front axle and optional body equipment will reduce payload allowance. Subject to manufacturing tolerance. **FAM** = Front axle plated mass. **RAM** = Rear axle plated mass. **GVM** = Gross vehicle mass. **GTM** = Gross train mass.

Specifications

	350M Chassis Cab	350L Double Cab
Chassis		
Engine availability – Refer to chart (page 54)		
Transmission – 115/140/200 PS – 6 speed MT82	●	●
Tyres – 185/75 R16C 104/102	●	●
Tyres – 195/75 R16C 107/105 (optional 1850kg Front Axle only) Std on HD350 & 460	○	○
Suspension – Front: Coil spring MacPherson strut, anti-roll bar	●	●
Suspension – Rear: Taper leaf + helper, anti-roll bar	●	●
Seating (Single Cab) – Driver's seat and dual passenger seat, lap and diagonal seat belts to all seats	●	
Seating (Double Cab) – 6-seat standard (driver, dual passenger, 3 seat bench in crew compartment)		●
Seating (Double Cab) – 7 seat, 4 seat rear bench with underseat stowage, lap and diagonal to outer seats, lap only to middle seats		○
Glazing – Laminated clear windscreen, toughened clear side and rear cab glass, tinted optional	●	●
Doors (Double Cab) – 4-door configuration with glazed rear doors		●
Electrical – Battery: 2 x 12V590CCA (60Ah @ 20 hr rate), Alternator 150A	●	●
Cold start (-29°C) includes twin 680 CCA (70Ah @ 20h rate) batteries	○	○
Tow Bar (RPO), 50mm ball hitch, 13 pin socket and Tailboard protection plate. Note: A Tailboard protection plate must be fitted to the tailboard if a Ford Accessory tow bar kit or aftermarket tow bar kit is installed.	○	○

Specifications

	350M Chassis Cab	350L Double Cab
Body		
Type – 3-way, manual top and bottom hinged tailboard, bottom hinged sideboards	●	●
Ram – Centre 5-stage chrome-plated	●	●
Tip Angle – Electrically-limited to 45 degrees by limit switch operating on ram	●	●
Electrical System – 12V system, 150A fuse, subframe-mounted isolation switch, emergency stop switch	●	●
Subframe – Hot-dip galvanised steel (powder-coated), 'C' section with cruciform	●	●
Load Bed – Hot-dip galvanised powder-coated 2.5 mm steel, box section crossbearers, roll formed edge to rear aperture	●	●
Headboard – Removable full-width, full-height. Perforated behind cab rear window. Rubber-finished top surface (ladder gantry)	●	●
Front and Rear Pillars – Replaceable powder-coated steel over centre pull-up latches	●	●
Sideboards – Body-coloured double-skin aluminium, Steel boards for HD350 & 460	●	●
Tailboard – Top and bottom hinged, double skin aluminium, Steel board for HD350 & 460	●	●
Fenders – Flexible thermoplastic, mounted on replaceable bolt-on fender brackets to subframe	●	●
Finish – Load bed, subframe and headboard – Slate grey powder-coat. Side and tailboards – Body colour, White: powder coated, all other colours 2-pack paint, cylinder casing: zinc passivated.	●	●
Load Lashing – 8 floor-mounted pull-up anchors (250 kg each), (6 on MWB D/Cab)	●	●
Roping hooks – 14 (S/Cab) 12 (LWB D/Cab) side mounted, 4 rear, 2 forward face of headboard	●	●
Body Prop – Integral subframe mounted	●	●
Body Warranty – 3-year, 100,000 miles.	●	●
Certification		
CE certified	●	●
EMC certified 72/245/EEC, 95/54/EC	●	●
TUV Certified 98/37/CE Machine directive – Safety requirements	●	●

● = Standard, ○ = Option, at extra cost. 350HD and 460 derivatives not available. Drawings are representative and may be subject to change.

2.85m/9ft 4in Dropside 300S

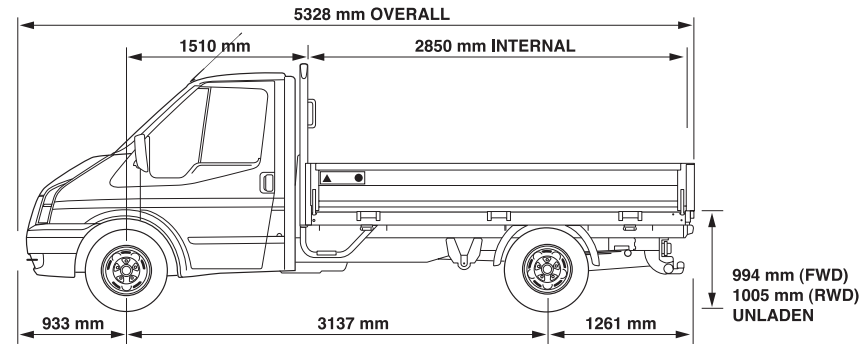

300 Models

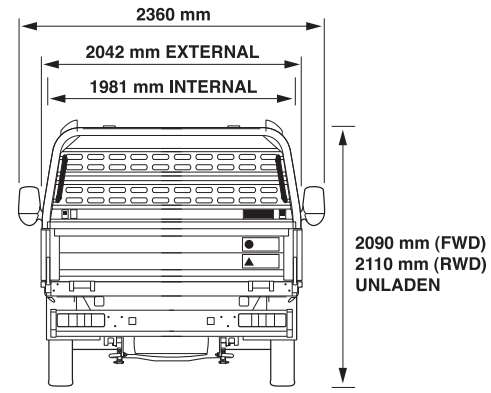

4.05m/13ft 3in Dropside 350EF

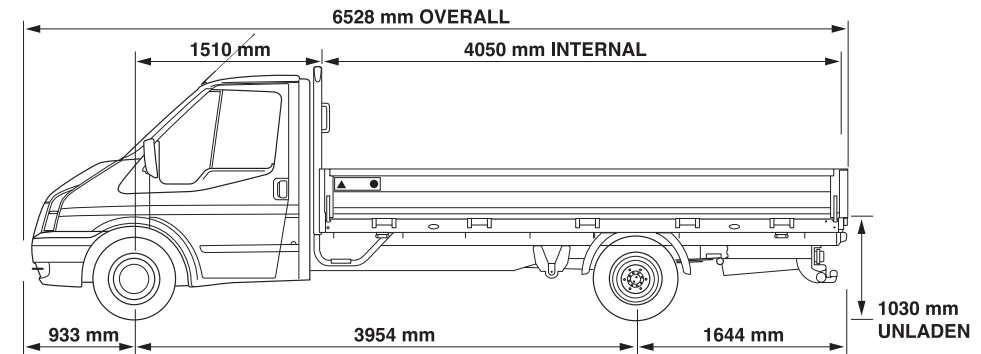

3.2m/10ft 6in Dropside 350M

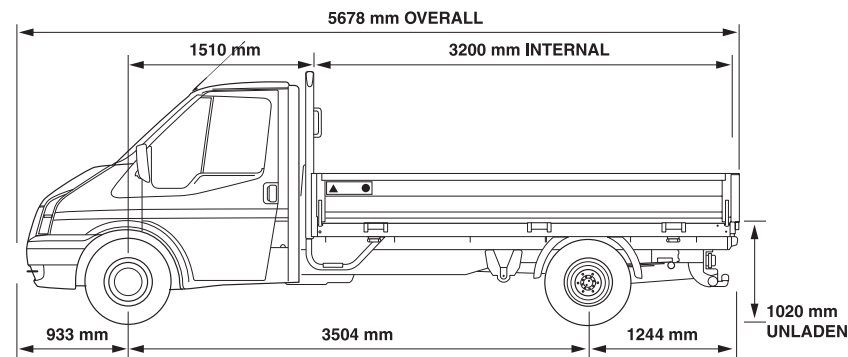

350 Models

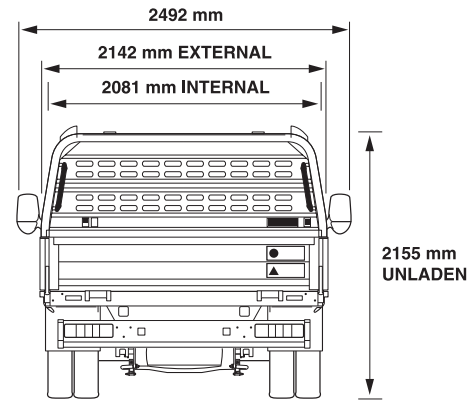

2.85/3.2m, 9ft 4in/10ft 6in Dropside 350L/EF Double Cab

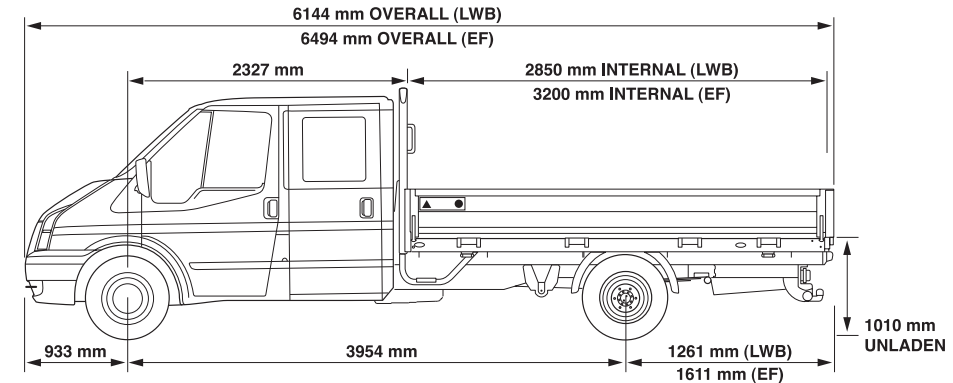

3.65m/12ft 0in Dropside 350L

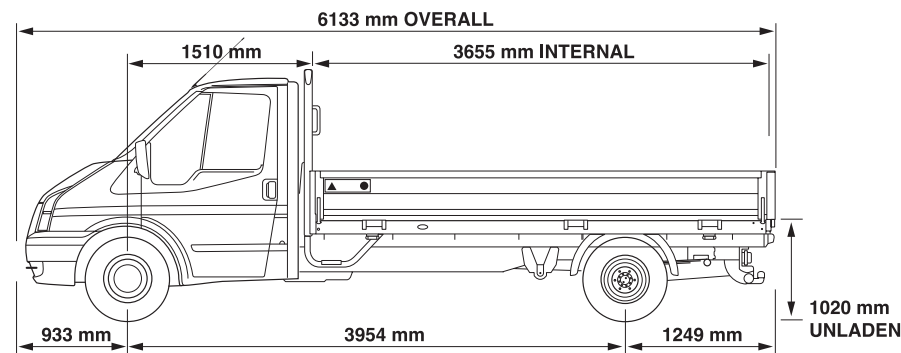

Weights and loads

	Rear axle ratio	300S FWD	300S RWD	350M	350L	350EF	350L Double Cab	350EF Double Cab
Plated weights (kg)								
FAM		1600	1600	1750	1750	1750	1750	1750
FAM – Optional				1850	1850	1850	1850	1850
RAM		1760	1850	2450	2450	2450	2450	2450
GVM		3000	3000	3500	3500	3500	3500	3500
GTM 110PS (2.2L)	4.23	3500	n/a	n/a	n/a	n/a	n/a	n/a
GTM 140PS (2.2L)	4.36	3500	n/a	n/a	n/a	n/a	n/a	n/a
GTM 100PS (2.4L)	5.11	n/a	5000	6000	6000	6000	6000	6000
GTM 115PS (2.4L)	4.27	n/a	n/a	6000	6000	6000	6000	6000
GTM 140PS (2.4L)	4.27	n/a	n/a	6300	6300	6300	6300	6300
GTM 200PS (3.2L)	4.10	n/a	n/a	6300	6300	6300	6300	6300
Payload (kg)								
5 speed trans*		1194	1056	1450	1413	1364	1297	1253
6 speed trans (115/140PS)*				1425	1388	1339	1272	1228
6 speed trans 200PS*				1348	1311	1262	1195	1151

*Payloads quoted are gross (full tank of fuel and fluids, no driver) and for minimum order specification, optional chassis equipment including 1850kg front axle and optional body equipment will reduce payload allowance. Subject to manufacturing tolerance. **FAM** = Front axle plated mass. **RAM** = Rear axle plated mass. **GVM** = Gross vehicle mass. **GTM** = Gross train mass. Drawings are representative and may be subject to change.

Specifications

	Chassis Cab	Double Cab
Chassis		
Engine availability – Refer to chart (page 54)		
Transmission – FWD: 5-speed, 4.36:1 VXT75 (300S only)	●	
Transmission – RWD: 100 PS – 5-speed MT75	●	●
Transmission – RWD: 115/140/200PS – 6-speed MT82	●	●
Rear Axle – 300 FWD: Dead Beam	●	
Rear Axle – 300S RWD: Salisbury type 51 single rear wheel 5.11 ratio	●	
Rear Axle – All 350 RWD: 100 PS – Salisbury type 53 dual rear wheel 5.11 ratio	●	●
Rear Axle – All 350 RWD: 115/140 PS – Dana dual rear wheel 4.27 ratio	●	●
Rear Axle – All 350 RWD: 200PS – Dana dual rear wheel 4.10 ratio	●	
Tyres – 300S FWD: 195/70 R15C 104/102	●	
Tyres – 300S RWD: 205/75 R16C 110/118	●	
Tyres – All 350 models: 185/75 R16C 104/102	●	●
Tyres – All 350 models: optional 195/75 R16C 107/105 tyres 1850kg front axle only	○	○
Suspension – Front: Coil spring MacPherson strut, front roll bar	●	●
Suspension – Rear: Taper leaf + helper (RWD), Taper leaf (FWD), rear roll bar – 350 models only	●	●
Seating (Single Cab) – Driver's seat and dual passenger seat, lap and diagonal seat belts to all seats	●	
Seating (Double Cab) – 6-seat standard (driver, dual passenger, 3 seat bench in crew compt.) Lap and diagonal seat belts to all seats.		●
Seating (Double Cab) – 7 seat, 4 seat bench with underseat stowage, lap and diagonal to outer seats, lap only to middle seats.		○
Glazing: Laminated clear windscreen, toughened clear side and rear cab glass, tinted optional	●	●
Doors (Double Cab) – 4 door configuration with glazed rear doors		●
Electrical – Battery: 12V, 2 x 590CCA (60Ah @ 20hr rate) – 350 Models, 1 x 680CCA (70Ah @ 20hr rate) – 300S Models. Primary battery isolator relay, twin battery installations only. Alternator: 150A	●	●
Cold start (-29°C) includes twin 680 CCA (70Ah @ 20h rate) batteries	○	○

Specifications

	Chassis Cab	Double Cab
Body		
Understructure – Full-length 'top hat' anodised 6082 T6 aluminium longitudinal members with galvanized closed 'C' section steel crossmembers	●	●
Raves – Aluminium, powder-coated slate grey, end outline marker lights fitted to all 350 models, side marker lights fitted to 350L, EF and (Double Cab) variants only	●	●
Load Deck – 15 mm phenolic resin-embossed birch plywood, replaceable	●	●
Gantry – 63.5 mm tubular steel frame with ladder stops. ASTM.B117-03 BS7479:1991 DIN.50.021-SS, 960hr salt spray compliant.	●	●
Headboard – 2 mm pressed Zintec sheet perforated behind cab rear window, replaceable. ASTM.B117-03 BS7479:1991 DIN.50.021-SS, 960hr salt spray compliant.	●	●
Stirrup Steps – Tubular steel side steps with extruded foot grip and molded footwell	●	●
Grab Handles – Headboard-mounted, powder-coated yellow	●	●
Rear Pillars – Removable extruded aluminium	●	●
Side and Tailboards – Extruded one piece 6063 T6 twin wall aluminium with integrated rubber bump strip and overcentre lever operated cam latches.	●	●
Fenders – Thermoplastic half round	●	●
Finish – Slate Grey powder coat – Entire gantry/headboard, raves, rear valence panel, stirrup steps. Zinc plated steel components – headboard uprights, lashing rings, roping eyes. Galvanised cross-bearers, anodised longitudinals.	●	●
Side and tailboards – Body colour, powder coat Frozen White, Colorado Red, all other colours 2-pack paint.	●	●
Hardware: Zinc plated to ASTM.B117-03 BS7479:1991 DIN.50.021-SS, 504hr salt spray compliant	●	●
Body Warranty – 3-year, 100,000 miles.	●	●
Optional Bodywork equipment from bodywork supplier (consult Dealer for further details)		
Tu-tone paint – bespoke body colour to cab colour	○	○
500kg column Tail Lift with mesh or folding solid platform, complies with BS 6109 part1:1981, BS EN 1756-1:2001. Note: Use of other Tail-Lift installations are not recommended and may invalidate warranty.	○	○
Reverse sensors for Tail Lift installation above	○	○
Tow bar with dual clevis/ball coupling specifically designed for use with Tail Lift.	○	○
Hiab013T 1.3 tonne/metre loader, front nearside mounted, BS EN 12999 & 98/37/EC compliant. Note: Use of other loader installations are not recommended and may invalidate warranty.	○	○
Reverse alarm	○	○

● = Standard, ○ = Option, at extra cost. 350HD, 460 derivatives not available.

3.7m/12ft 1in Box Van 350L

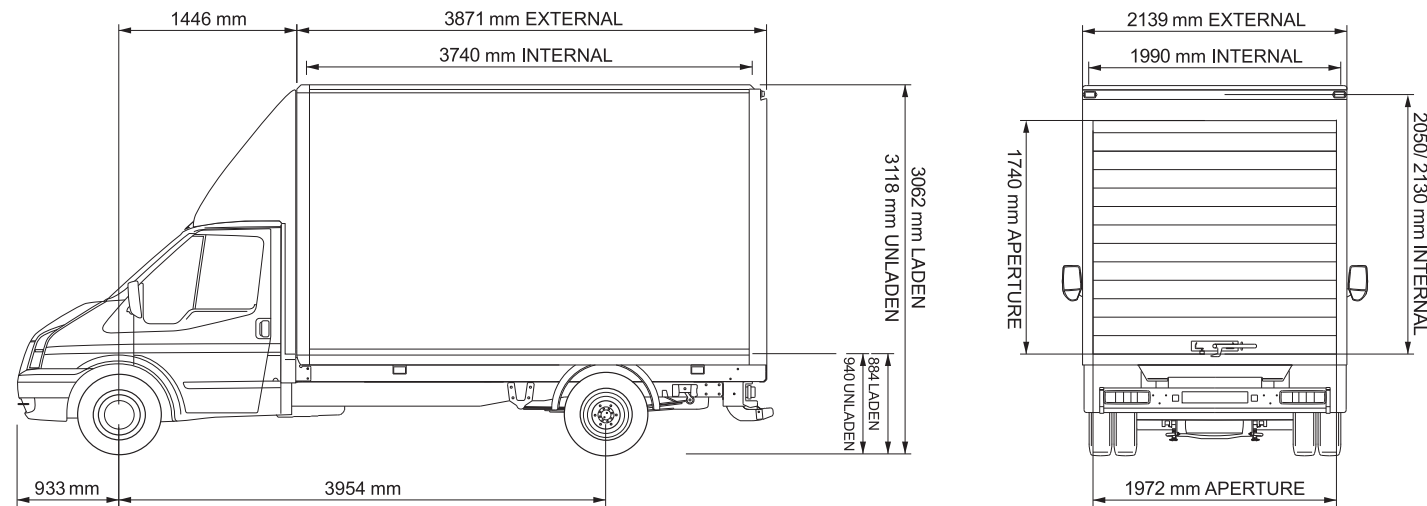

4.1m/13ft 5in Box Van 350EF

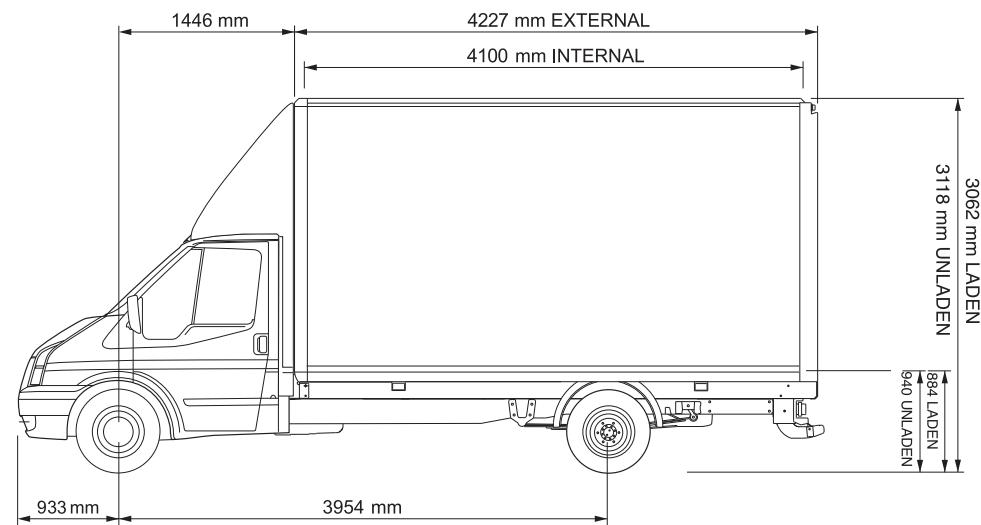

Illustrations above show optional rear door latch

Weights and loads

	Rear axle ratio	350L	350EF
Plated weights (kg)			
FAM		1750	1750
FAM – Optional (recommended for optional luton head)		1850	1850
RAM		2450	2450
GVM		3500	3500
GTM 115PS (2.4L)*	4.27	6000	6000
GTM 140PS (2.4L)*	4.27	6300	6300
GTM 200PS (3.2L)*	4.10	6300	6300
Payload			
4 cyl 115/140PS*		1075	1000
5 cyl 200PS		998	923
Cubic capacity m ³		15.5	17.1

*RPO trailer tow attachment not available, furthermore aftermarket tow attachments are precluded by the rear step or optional Tail-Lift. *Payloads quoted are gross (full tank of fuel, oil and fluids, no driver) and for minimum specification, optional chassis equipment including 1850kg front axle and optional body equipment will reduce payload allowance. Subject to manufacturing tolerance. **FAM** = Front axle plated mass. **RAM** = Rear axle plated mass. **GVM** = Gross vehicle mass. **GTM** = Gross train mass.

Specifications

	Chassis	Cab
Engine availability – Please refer to chart (page 54)		
Transmission – 6-speed MT82		●
Rear Axle – 115/140PS PS – dual rear wheel 4.27 ratio		●
Rear Axle – 200 PS – dual rear wheel 4.10 ratio		●
Tyres – 185/75 R16C 104/102 (1750kg front axle)		●
Tyres – 195/75 R16C 107/105 (1850kg front axle)		○
Suspension – Front, coil spring MacPherson strut. Rear, taper leaf + helper. Roll bars front and rear		●
Seating – Driver's seat and dual passenger seat, lap and diagonal seat belts to all seats		●
Electrical – Battery: 12V 2 x 590CCA (60Ah @ 20 hr rate) batteries, primary battery isolator relay		●
Cold start (-29°C) includes twin 680 CCA (70Ah @ 20h rate) batteries – recommended if optional Tail-Lift specified		○
Electrical – Alternator: 150 Amp		●
Colour – Frozen White only		●
Body		
Type – Ply/GRP panel Box, shutter door, alu framed with steel rear frame for retro-fit Tail-lift capability (Ratcliff only)		●
Colour – Frozen white only – Ply/GRP composite panels and uPVC rear shutter exterior and interior. Natural anodised aluminium exterior frame work and mill finish aluminium internal load restraint rails		●
Understructure – Full-length anodised 6082 T6 aluminium longitudinals, galvanised closed 'C' section crossbearers		●
Bodysides – Self-coloured 6mm Ply/GRP composite panels, aluminium reinforcements molded into interior surface for load retention rails		●
Structure – Extruded aluminium frame anodised, with cast aluminium corner sockets		●
Rear Frame – Powder-coated steel frame incorporating end outline marker lamps, rain channel, anti-slip tape to rear aperture step. ASTM.B117-03 BS7479:1991 DIN.50.021-SS, 960hr salt spray compliant.		●

Specifications

	Chassis	Cab
Roof – Translucent GRP roof panels with alternate alloy panels, crowned aluminium roof sticks		●
Floor – Embossed 15 mm thick phenolic resin full birch plywood		●
Door – uPVC slat rear shutter, extruded aluminium lower plank powder-coated white with lower lip seal. External rubber lip seals to door frame aperture sides, two exterior grab handles with one internal webbing pull cord.		●
Door Lock – Slam shut latch with built in lock, door latched to door frame sides using paddle latch's. Internal emergency door release system with high strength steel load protection panel to lower shutter panel		●
Handrail – 3/4 height, mounted at the rear near-side, with integral switchgear		●
Lighting – 35W work lamp mounted on rear of interior handrail, can be rotated to illuminate interior and exterior		●
Rear Step – Full-width aluminium, powder-coated grey		●
Load Lashing – Interior Load restraint system, 4 horizontal rails per bodyside with twin integral orange coloured rubber strips per rail. 3x400kg rated telescopic 6082 T6 load retention poles.		●
Hardware: Zinc plated to ASTM.B117-03 BS7479:1991 DIN.50.021-SS, 504hr salt spray compliant		●
Body Warranty – 3-year, 100,000 miles		●
Optional Bodywork equipment from bodywork supplier (consult Dealer for further details)		
Luton head (1850kg front axle recommended)		○
Luton head load retention net		○
Tail-lift - Ratcliff RQ08 lightweight aluminium column lift, 500Kg capacity, trolley stops, dual control, 950mm platform depth. RPO Cold Start (-29°C) twin 680 CCA (70Ah @ 20h rate) batteries recommended at extra cost with this option.		○
Additional telescopic load retention poles		○
Additional load lashing rails		○
Ply lining kit		○
Reverse alarm		○

● = Standard, ○ = Option, at extra cost. RPO tow bar is not available, 350HD and 460 derivatives not available. **Note:** Drawings are representative and may be subject to change. Optional rear door latch shown, fittings and equipment subject to change.

4.0m/ 13ft 1in Curtainside 350EF

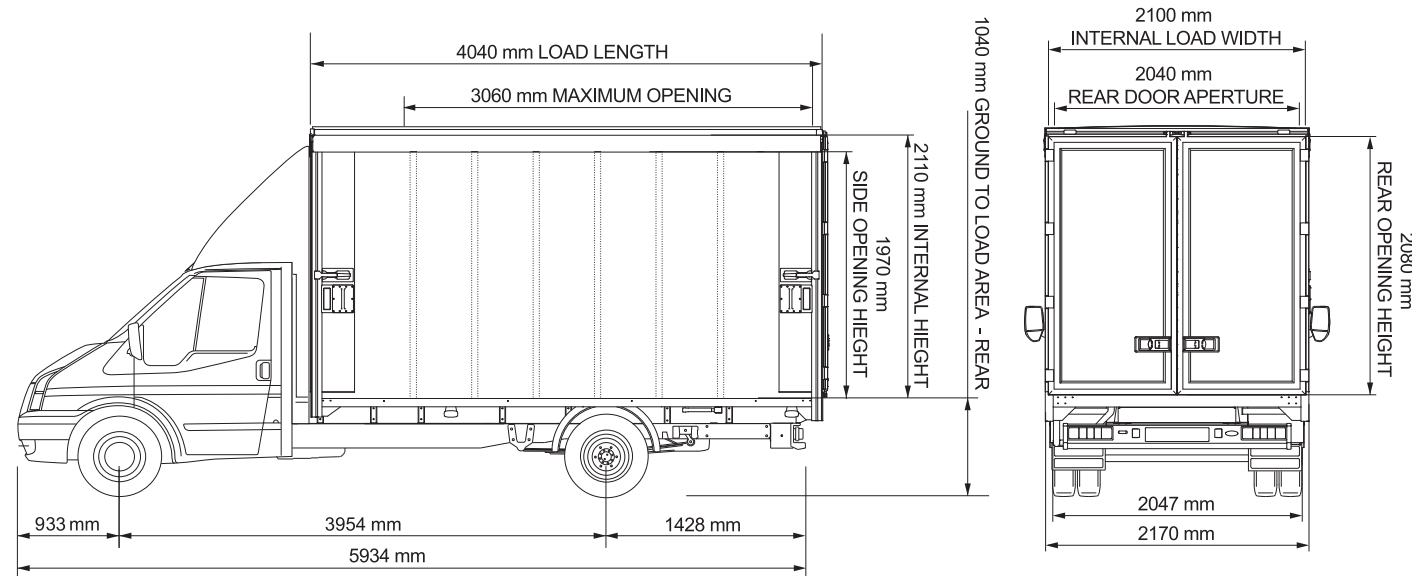

Note: Illustrations above shown optional curtain grab handles. Rear door handles are subject to change, handle position will be changed to below the door.

Weights and loads

	Rear axle ratio	350EF	460 EF
Plated weights (kg)			
FAM		1750	1850
FAM – Optional		1850	–
RAM		2450	3300
GVM		3500	4600
GTM 115PS (2.4L)*	4.27	6000	–
GTM 140PS (2.4L)*	4.27	6300	6500
GTM 200PS (3.2L)*	4.10	6500	6500
Payload			
4cyl 115/140PS*		1065	1948
5 cyl 200PS*		988	1870
Cubic capacity m ³		17.1	17.1

*Payloads quoted are gross (full tank of fuel, oil and fluids, no driver) and for minimum specification, optional chassis equipment including 1850kg front axle and optional body equipment will reduce payload allowance. Subject to manufacturing tolerance. **FAM** = Front axle plated mass. **RAM** = Rear axle plated mass. **GVM** = Gross vehicle mass. **GTM** = Gross train mass.

Specifications

	Chassis Cab
Chassis	
Engine availability – Refer to chart (page 54)	
Transmission – 6 speed MT82	●
Rear Axle – 115/140 PS – dual rear wheel 4.27 ratio	●
Rear Axle – 200 PS – dual rear wheel 4.10 ratio	●
Tyres – 185/75 R16C 104/102 (1750kg front axle)	●
Tyres – 195/75 R16C 107/105 (1850kg Front Axle) Std on 460	○
Suspension – Front, coil spring MacPherson strut	●
Suspension – Rear: Taper leaf + helper, anti-roll bar	●
Seating – Driver's seat and dual passenger seat, lap and diagonal seat belts to all seats	●
Electrical – Battery: 12V 2 x 590CCA (60Ah @ 20 hr rate) batteries, primary battery isolator relay	●

Specifications

	Chassis Cab
Cold start (-29°C) includes twin 680 CCA (70Ah @ 20h rate) batteries – recommended if additional electrical equipment fitted.	○
Electrical – Alternator: 150 Amp	●
Colour – Frozen White only	●
Body	
Type – Sliding curtain, dual opening rear doors	●
Colour – Curtains: Mid blue standard (other colours available). Doors: Frozen white with natural anodised aluminium framework. Overcab airdam: Frozen white gel coat GRP	●
Overcab air dam with cab side streamers (Gel coat Frozen white only)	●
Curtains – Reinforced PVC with integral vertical box section aluminium stiffeners. Top hung rollers with adjustable end latches to maintain curtain tension.	●
Bulkhead – Double skinned aluminium with 6 wooden lath's	●
Understructure – Full-length aluminium longitudinals and crossbearers, steel bulkhead buttress plates	●
Structure – Extruded anodised aluminium frame	●
Roof – Translucent GRP with top hat roof bows	●
Floor – Embossed 18 mm thick phenolic resin full birch plywood	●
Rear Doors – 270° powder coated aluminium panel doors, internal door locking mechanism, bottom lockable handle. (Powder coat Frozen White only)	●
Rear Door retainers – Telescopic Brolly handle retainers in the 270 open position, stowed under floor when not deployed	●
Lighting – Internal rotating high mounted 50W halogen spot lamp	●
Load Lashing – Pull-up load anchorage rings mounted in raves, 4 per side. 2 lashing rings mounted on bulkhead	●
Curtain stops - Rave mounted pull up & turn lock stops holding curtain open in the forward or rearward positions	●
Step & Grab handle - Nearside mounted stirrup step with bulkhead mounted grab handle	●
Side Guards - 460 only	-
Body Warranty – 3-year, 100,000 miles	●

● = Standard, ○ = Option, at extra cost. **Note:** Drawings are representative and may be subject to change. Optional side curtain grab handles shown, rear door handle position changed to below the door in production, fittings and equipment subject to change.

Model availability

	Driveline	SWB 300S	MWB 350M	MWB HD350M	MWB 460M	LWB 350L	LWB HD350L	LWB 460L	LWB 350EF	LWB HD350EF	LWB 460EF	Axle Ratio
Chassis Cab – Dual rear wheels												
2.4 Duratorq TDCi Diesel 100 PS	RWD		●			●			●			5.11
2.4 Duratorq TDCi Diesel 115 PS	RWD		●			●			●			4.27
2.4 Duratorq TDCi Diesel 140 PS	RWD		●	●	●	●	●	●	●	●	●	4.27
3.2 Duratorq TDCi Diesel 200 PS	RWD		●	●	●	●			●	●	●	4.10
Chassis Cab – Single rear wheels												
2.4 Duratorq TDCi Diesel 100 PS	RWD	●	○			○			○			5.11
2.4 Duratorq TDCi Diesel 115 PS	RWD		○			○			○			4.27
2.4 Duratorq TDCi Diesel 140 PS	RWD		○			○			○			4.27
2.4 Duratorq TDCi Diesel 140 PS	AWD		●									4.27
2.2 Duratorq TDCi Diesel 115 PS	FWD	●										4.23
2.2 Duratorq TDCi Diesel 140 PS	FWD	●										4.36
Double Cab – Dual rear wheels only												
2.4 Duratorq TDCi Diesel 100 PS	RWD					●			●			5.11
2.4 Duratorq TDCi Diesel 115 PS	RWD					●			●			4.27
2.4 Duratorq TDCi Diesel 140 PS	RWD					●	●	●	●	●	●	4.27
3.2 Duratorq TDCi Diesel 200 PS	RWD					●	●	●	●	●	●	4.10

All models are 6-speed manual transmission, except for the 2.4 Duratorq TDCi 100PS which is 5-speed manual, unless otherwise stated.

OSS Model availability

	Driveline	Single Cab 300S	350M	HD350M	460M	350L	350EF	460EF	Double Cab 350L	HD350L	460L	350EF
1-way Tipper												
2.4 Duratorq TDCi Diesel 100 PS	RWD		○						○			
2.4 Duratorq TDCi Diesel 115 PS	RWD		○						○			
2.4 Duratorq TDCi Diesel 140 PS	RWD		○	○	○				○	○	○	
3.2 Duratorq TDCi Diesel 200 PS	RWD		○		○				○		○	
3-way Tipper												
2.4 Duratorq TDCi Diesel 115 PS	RWD		○						○			
2.4 Duratorq TDCi Diesel 140 PS	RWD		○	○	○				○	○	○	
3.2 Duratorq TDCi Diesel 200 PS	RWD		○		○				○		○	
Dropside												
2.2 Duratorq TDCi Diesel 115 PS	FWD	○										
2.2 Duratorq TDCi Diesel 140 PS	FWD	○										
2.4 Duratorq TDCi Diesel 100 PS	RWD	○	○			○	○		○			○
2.4 Duratorq TDCi Diesel 115 PS	RWD		○			○	○		○			○
2.4 Duratorq TDCi Diesel 140 PS	RWD		○			○	○		○			○
3.2 Duratorq TDCi Diesel 200 PS	RWD		○			○	○		○			○
Box Van												
2.4 Duratorq TDCi Diesel 115 PS	RWD					○	○					
2.4 Duratorq TDCi Diesel 140 PS	RWD					○	○					
3.2 Duratorq TDCi Diesel 200 PS	RWD					○	○					
CurtainSlider												
2.4 Duratorq TDCi Diesel 115 PS	RWD					○	○					
2.4 Duratorq TDCi Diesel 140 PS	RWD					○	○					
3.2 Duratorq TDCi Diesel 200 PS	RWD					○	○					

Engine data

	Engine technical features	Maximum power ^o	Maximum torque ^o	Transmission
Front wheel drive				
2.2 Duratorq TDCi Diesel 115PS (85 kW) 2198 cc	4 cylinders in line; DOHC; 16 valves; alloy cylinder head; direct injection with high-pressure, common-rail, multipoint fuel injection system; VNT turbocharger with intercooler; dual-mass flywheel; electronic EGR	115PS (85 kW) at 3500 min ⁻¹ (rpm)	285 Nm at 1800-2300 min ⁻¹ (rpm)	6-speed transaxle
2.2 Duratorq TDCi Diesel 140PS (103 kW) 2198 cc	4 cylinders in line; DOHC; 16 valves; alloy cylinder head; direct injection with high-pressure, common-rail, multipoint fuel injection system; VNT turbocharger with intercooler; dual-mass flywheel; electronic EGR	140PS (103 kW) at 3500 min ⁻¹ (rpm)	350 Nm at 1800-2400 min ⁻¹ (rpm)	6-speed transaxle
Rear wheel drive				
2.4 Duratorq TDCi Diesel 100PS (74 kW) 2402 cc	4 cylinders in line; DOHC; 16 valves; alloy cylinder head; direct injection with high-pressure, common-rail, multipoint fuel injection system; turbocharger with intercooler; single-mass flywheel; electronic EGR	100PS (74 kW) at 3500 min ⁻¹ (rpm)	285 Nm at 1600-2200 min ⁻¹ (rpm)	5-speed
2.4 Duratorq TDCi Diesel 115PS (85 kW) 2402 cc	4 cylinders in line; DOHC; 16 valves; alloy cylinder head; direct injection with high-pressure, common-rail, multipoint fuel injection system; turbocharger with intercooler; single-mass flywheel; electronic EGR	115PS (85 kW) at 3500 min ⁻¹ (rpm)	310 Nm at 1750-2000 min ⁻¹ (rpm)	6-speed
2.4 Duratorq TDCi Diesel 140PS (103 kW) 2402 cc	4 cylinders in line; DOHC; 16 valves; alloy cylinder head; direct injection with high-pressure, common-rail, multipoint fuel injection system; VNT turbocharger with intercooler; single-mass flywheel; electronic EGR	140PS (103 kW) at 3500 min ⁻¹ (rpm)	375 Nm at 2000 min ⁻¹ (rpm)	6-speed
3.2 Duratorq TDCi Diesel 200PS (147 kW) 3199 cc	5 cylinders in line; DOHC; 20 valves; alloy cylinder head; direct injection with high-pressure, common-rail, multipoint fuel injection system; VNT turbocharger with intercooler; dual-mass flywheel; electronic EGR	200PS (147 kW) at 3500 min ⁻¹ (rpm)	470 Nm at 1750-2500 min ⁻¹ (rpm)	6-speed

^o Tested in accordance with ISO 1585. Please note: All Transit engines are Stage IV emissions level.

Mechanical features

	Chassis Cabs	Double Cabs
Brakes		
Dual-circuit, with self-adjusting servo-assistance and ABS. Front and rear discs	●	●
Fuel tank		
Standard – 80 litres	●	●
Long range – 103 litres (RWD diesel engines only, not available on SWB models)	○	○
Steering		
Power-assisted steering	●	●
Suspension		
Front – independent MacPherson struts, variable rate coil springs, stabiliser bar and gas-pressurised shock absorbers. Rear – leaf springs and gas-pressurised shock absorbers	●	●
Engine and Transmission		
cDPF (coated Diesel Particulate Filter)	○	○
Enhanced traction All Wheel Drive (AWD) – Generation II with smooth engagement and manual override (only available with 350M 2.4L TDCi 140PS)	○	
Single Mass Flywheel (2.4L TDCi RWD models only)	●/–	●/–
Speed limiter – 56 mph (90 km/h) (standard on 460 models)*	○/●	○/●
Speed limiter – 62 mph (100 km/h)	○	○
Speed limiter – 70 mph (112 km/h)	○	○
Heavy duty front axle		
1850 kg (option on 350 models only; includes 195/75R 16 tyres; standard on 350HD and 460 models)	○	○

● = Standard, ○ = Option, at extra cost. *Legal requirement on some variants from Jan 1st 2008. For full legislation detail please refer to VOSA.

Safety and security

	Chassis Cabs	Double Cabs
Safety		
Anti-lock brakes – Electronic, 4-wheel (includes rear disc brakes)	●	●
Electronic Stability Programme (ESP)* with Hill Launch Assist (HLA) (not available on AWD model)	●	●
Airbag – Driver's	●	●
Airbag – Outer front passenger's (standard on AWD with deactivation switch)	○	○
Airbag – Side airbags (only available with single passenger seat packs 30 and 31)	○	○
Seat belts – 3-point diagonal inertia reel (all seats – except where quad seat is fitted)	●	●
Security		
Alarm – Perimeter (includes Ford RPO trailer coupling, when fitted; cannot be ordered when Category 1 alarm system specified)	○	○
Alarm – Cab interior sensing – Insurance approved Thatcham Cat 1 alarm – approval number TCL1-131/1205 (includes Ford RPO trailer coupling, when fitted; includes remote locking with 2 key fobs; not available when Perimeter alarm specified)	○	○
Audio – Enhanced 'Keycode' anti-theft coding	●	●
Fuel cap – Locking	●	●
Immobiliser – Safeguard Passive Anti-Theft System (PATS) (Insurance-approved Category 2 immobiliser)	●	●
Locks – High security lock-in-latch system, shielded with strengthened mountings	●	●
Locks – Remote keyless entry central, double locking with 1 key fob	●	●
Locks – Remote keyless entry central, double locking with 2 key fobs	○	○
Locks – Auto re-locking, doors re-lock after 45 seconds if no door is opened (only available with remote locking)	●	●
Locks – Audio mis-lock feedback, audible signal if a door is ajar when locking activated (only available with remote locking)	●	●
Locks – Auto locking on drive-away, doors automatically lock at 5 mph (only available with remote locking)	●	●
Locks – Key-operated bonnet release	●	●
Locks – Slam locking	○	○
Vehicle Identification Number – Visible	●	●

● = Standard, ○ = Option, at extra cost. *Includes electronic brake-force distribution (EBD), Hydraulic Brake Assist (HBA) and Brake Traction Control System (BTCS). **For details of the configurations available please consult your Ford Dealer. **Please Note:** Configurable locking must be defined at the time of order, it cannot be ordered as a Dealer-fitted option or accessory.

Exterior features

	Chassis Cabs	Double Cabs
Exterior appearance and styling		
Body – Low roof	●	●
Bodyside mouldings – Black	○	○
Bumper – Full width, front	●	●
Bumper – Front, body colour grille and front bumper centre piece (includes fog lights and integrated stainless steel step trim plates)	□	□
Paint – Metallic	○	○

Exterior features

	Chassis Cabs	Double Cabs
Wheel and tyres		
Wheelcovers – Front hub caps	●	●
Wheelcovers – Full (single rear wheel models only)	□	
Tyres – Mud and snow (Goodyear; single rear wheel models only)	○	
RWD Dual Rear Wheels		
Wheels – 5J x 16" steel wheels and 185/75 R16C 104/102 tyres (350M, L and EF) Dual rear wheel pack 1	●	●
Wheels – 5J x 16" steel wheels and 195/75 R16C 107/105 tyres, 1850 kg Heavy duty front axle (350HD/460 M and EF, also optional on 350 M, L and EF) Dual rear wheel pack 2	●	●
FWD Single Rear Wheels		
Wheels – 5.5J x 15" steel wheels and 195/70 R15C 104/102 tyres (300S)	●	
Wheels – 5.5J x 16" steel wheels and 215/75 R16C 113/111 tyres (350M, 350L)	●	
Wheels – 5.5J x 16" steel wheels and 215/75 R16C 116/114 tyres (350 EF)	●	
RWD Single Rear Wheels		
Wheels – 5.5J x 16" steel wheels and 205/75 R16 110/108 tyres (300S)	●	
Wheels – 5.5J x 16" steel wheels and 215/75 R16C 113/111 tyres (350M, 350L)	○	
Wheels – 5.5J x 16" steel wheels and 215/75 R16C 116/114 tyres (350 EF)	○	
Exterior functional		
Doors – With drop window and assist handle	●	●
Doors – Double cab rear doors, glazed		●
Door mirrors – Blind spot eliminator	●	●
Door mirrors – Electrically-operated*	○	○
Glass – Light tint complete	●	●
Heated windscreen – Quickclear	□	□
Mudflaps – Front	●	●
Tow bar with 13-pin electrics. The optional digital Tachograph may be required under UK, EC or AETR law, reference:- Drivers Hours and Tachograph rules for Goods Vehicles in the UK or Europe	○	○
Recovery eyes – Front and rear	●	●
Windows – Front, electrically-operated	●	●
Windows – Crew doors, fixed		●
Windows – Rear, fixed	●	●
Wipers – Front two speed with electric wash	●	●
Exterior lighting		
Halogen headlights, side lights, rear fog lights, reversing lights	●	●
Front fog lights	○	○
Headlight levelling	●	●
Roof marker lights	●	●
Headlights – 'Home Safe' facility, 30 seconds duration	●	●

● = Standard, ○ = Option, at extra cost, □ = Part of an Option Pack, at extra cost. *Power and heated mirror available from mid 2009

Audio and communications

	Chassis Cabs	Double Cabs
Stereo radio/single CD player – Model 6000 RDS with auxilliary MP3 connector, 2 speakers, 24 station pre-sets; 2x17 watts power output and remote steering column-mounted controls	●	●
Stereo radio/6-disc CD player – Model 6006 RDS with auxilliary MP3 connector, 2 speakers, 24 station pre-sets; 2x17 watts power output and remote steering column-mounted controls	○	○
Satellite Navigation FX system – Full 7 digit postcode capability; 5" TFT colour display; stereo radio/single CD player with auxiliary MP3 capability; 2 speakers; 24 station pre-sets; 2x17 watts power output and remote steering column-mounted controls.	○	○
Bluetooth® module with wireless integration between phone and audio system and voice dialling	○	○

● = Standard, ○ = Option, at extra cost. The Bluetooth® wordmark and logos are owned by the Bluetooth SIG, Inc. and any use of such marks by Ford Motor Company is under licence. Other trademarks and trade names are those of their respective owners.

Interior features

	Chassis Cabs	Double Cabs
Carpet and trim		
Door trim – Front, moulded with pull handles and storage pockets	●	●
Floor covering – Rubber	●	●
Headlining – Moulded	●	●
Interior lighting		
Courtesy lights – Header-mounted, front door-operated	●	●
Interior lighting/battery saver – 30 minutes	●	●
Instruments and controls		
Instruments – Speedometer, tachometer, odometer, trip recorder, fuel gauge, water temperature gauge and digital clock	●	●
Warning lights for oil pressure, direction indicator, high beam, lights on, ignition/alternator, brake failure, loadspace light on (where fitted), airbag(s) (where fitted)	●	●
Shift indicator light	●	●
Water in fuel filter with sensor	●	●
Illuminated heater controls – 3-speed fan. Four vents with temperature and direction control, two dedicated side window demisters	●	●
Air vents – Bright finish	●	●
Trip computer (functionality includes clock, distance to fuel empty, average fuel consumption, average speed, outside air temperature)	○	○
Battery – Single 680 CCA (70Ah @ 20h rate) (FWD 300S only)	●	●
Battery – Twin 590 CCA (60Ah @ 20h rate) with primary battery isolator (except FWD 300S)	●	●
Cold start (-20°C)	●	●
Cold start (-29°C) includes twin 680 CCA (70Ah @ 20h rate) batteries (730 cold cranking amps per battery)	○	○
Tachograph – Digital, electronic, 24-hour*	○	○
Cruise control (includes leather-wrapped steering wheel with silver effect spokes and leather gear knob with aluminium insert)	□	□
Control stalks – Column-mounted for indicators and wash/wipe functions	●	●
Seats		
Seat trim – Tomy fabric	●	●
Seat trim – York weave vinyl	○	○

Interior features

	Chassis Cabs	Double Cabs
Front seats – Tomy / 8-way driver's (fore/aft; recline; height and tilt) / dual passenger's seat / manual adjustment with fixed armrest; height-adjustable head restraints / (administrative use – seat pack 22)	●	●
Front seats – Tomy / 8-way driver's (fore/aft; recline; height and tilt) / single, 4-way passenger's seat (fore/aft and recline) / manual adjustment with fixed armrest; height-adjustable head restraints / heated / (administrative use – seat pack 21)	○	○
Front seats – Tomy / 10- way driver's (fore/aft; recline; height; tilt and lumbar) / dual passenger's seat / manual adjustment with fixed armrest; height-adjustable head restraints / (administrative use – seat pack 23)	○	○
Front seats – Tomy / 8-way driver's (fore/aft; recline; height and tilt) / single, 8-way passenger's seat (fore/aft; recline; height and tilt) / manual adjustment with fixed armrest; height-adjustable head restraints / side airbags (automatically specifies passenger front airbag at extra cost) / (administrative use – seat pack 30)	○	○
Front seats – Tomy / 10-way driver's (fore/aft; recline; tilt and lumbar) heated / single, 10-way passenger's seat (fore/aft; recline; height; tilt and lumbar) / manual adjustment with fixed armrest; height-adjustable head restraints heated / side airbags (automatically specifies passenger front airbag at extra cost) / (administrative use – seat pack 31)	○	○
Front seats – York / 8-way driver's (fore/aft; recline; height and tilt) / dual passenger's seat / manual adjustment with fixed armrest; height-adjustable head restraints / (administrative use – seat pack 27)	○	○
Rear seats – Bench seat (3 passengers) with height-adjustable head restraints (not available on 350HD, 460 variants) rear seat pack 2		●
Rear seats – Quad seat and stowage / standard on 350HD, 460 Double Chassis Cab) rear seat pack 11		○/●
Seat belts – Height-adjustable mount, driver's and outer front passenger's side	●	●
Rear seat belts – 3-point inertia reel (quad seat – centre seats – lap straps only).		●
Comfort and convenience		
Air conditioning – Front, CFC-free	○	○
Bottle holder – Twin, 2 litre bottle capacity, facia-mounted	●	●
Cup holder – Twin, facia-mounted, drop-down	●	●
Glovebox – With lid and A4 file storage capability, moulded hook in lid	●	●
Grab handle – passenger side 'A' pillar mounted	○	○
Heater – Recirculation	●	●
Power point socket (located in driver's top stowage bin)	●	●
Storage – Front door map pockets	●	●
Storage – Driver's and passenger's side, storage compartments on facia top with lift up lids	●	●
Storage – Central slot for 1" A4 binder or clipboard storage	●	●
Storage – Passenger's side open storage area (not available with front passenger's airbag)	●	●
Storage – Centre stack-mounted car park/toll ticket holder	●	●
Sunvisors – Two, swivelling	●	●
Tray – Centre facia-mounted, swivelling with two cupholders and a pen groove	●	●

● = Standard, ○ = Option, at extra cost. *Tachograph – Legal requirement on 460 variants. Exemptions may apply. For full legislation, please refer to VOSA. For vehicles operating over 3500Kg GVM or GTM a tachograph may be required as defined in legislation – 'Drivers Hours and Tachograph Rules for Good Vehicles in the UK and Europe' therefore when specifying a tow-bar of 460 derivative, determine if a tachograph is required to comply with legislation. (Please note that a digital tachograph cannot be retro fitted to stock FWD vehicles – factory order only).

Option packs

	Chassis Cabs	Double Cabs
Visibility Pack – Quickclear heated windscreen; electrically-operated and heated door mirrors	○	○
Premium Visibility Pack – Quickclear heated windscreen; electrically-operated and heated door mirrors; automatic headlights; automatic front wipers with rain sensor; instrument panel dimmer; front fog lights and stainless steel front bumper step plates	○	○
Appearance Pack – Body colour grille and front bumper centre piece; front fog lights; full wheelcovers* and bodyside mouldings	○	○
Trunker Pack – Cruise control (includes leather-wrapped steering wheel with silver effect spokes and leather gear knob with aluminium insert) and trip computer	○	○
Smoker's Pack – Front ashtray and cigar lighter	○	○

○ = Option, at extra cost. *Wheelcovers not available with dual rear wheel variants

Special vehicle options

	SVO option no.	Chassis Cab	Double Cab
Special vehicle options			
Wheels and tyres			
Omit Spare Wheel, Carrier, Jack & Tools.(CSGAA)	A026	○	○
Body			
Omit Passenger seat. (BVFDL)	A304	○	○
Double Cab Utility Cab - delete rear seat and windowless rear crew doors. (AALDI)	A989		○
Exhaust			
Mid side exit exhaust (RHS) (F2CAF)	A890	○	○
Electrical			
Cyclic durable second battery, 300 FWD – 1x70Ah + 1x90Ah cyclic durable, total 2 batteries. (HTCAC)	A736	○	
Cyclic durable second battery, 350 FWD, 350/430 RWD – 1x60Ah + 1x90Ah cyclic durable, total 2 batteries. (HTCAC)	A736	○	○
Cyclic durable second and third battery, 300 FWD – 1x70Ah + 2x90Ah cyclic durable, total 3 batteries.* (HTCAE)	A738	○	
Cyclic durable second and third battery, 350 FWD, 350/430 RWD – 1x60Ah + 2x90Ah cyclic durable, total 3 batteries.* (HTCAE)	A738	○	○
Auxiliary fuse panel – 6 fuses. (JZGAB)	A526	○	○
Switch and wiring only for single amber beacon. (JZFAB)	A605	○	○
Engine rpm speed control for power take off, 1300-3000 rpm. (DCNAB)	A003	○	○
Switch & wiring for sigle amber beacon.	A605	○	○
Switch & wiring for dual amber beacon.	A606	○	○
Paint			
Special Paint, 180 colours available, consult Dealer for details**		○	○

○ = Option, at extra cost. *= Single passenger seat mandatory, 3rd battery located under passenger seat. **SVO paint suffix must be entered at time of ordering. *Internal bulkhead / flooring etc. is available as an OSS supplier option to form a full steel secure cab on OSS models only

Colour and trim

Model	Seat trim	Trim colour	Solid Body Colours			Metallic Body Colours							
			Colorado Red	Frozen White*	Blazer Blue	Moondust Silver	Panther Black	Tango ¹	Sea Grey	Chill	Avalon	Vision ²	
Transit Chassis Cab	Tomy fabric	Lichen	●	●	●	○	○	○	○	○	○	○	○
	York Weave vinyl	Lichen	○	○	○	○	○	○	○	○	○	○	○
Transit Chassis Double Cab	Tomy fabric	Lichen	●	●	●	○	○	○	○	○	○	○	○
	York Weave vinyl	Lichen	○	○	○	○	○	○	○	○	○	○	○

● = Standard, ○ = Option, at extra cost. *The Ford Transit 'One-Stop' Box Van and CurtainSlider are only available in Frozen White. ¹Available until Spring 2010. ²Available from Spring 2010.



1



2



3



4



6



7



5



9



10



8



12



11

Classic colours

- 1 Colorado Red
- 2 Frozen White*
- 3 Blazer Blue
- 4 Moondust Silver*
- 5 Panther Black*

Contemporary colours

- 6 Tango* (available until spring 2010)
- 7 Sea Grey*
- 8 Chill*
- 9 Ocean* (available until spring 2010)
- 10 Avalon*
- 11 Ink Blue* (not available in UK)
- 12 Vision* (available from spring 2010)

Ford understands the colour you select may represent your corporate colour choice for years to come. Therefore we recommend you select one of our classic colours or, if you need a unique colour for your fleet, speak to your local dealer about our SVO colours that offer you more than 100 colour options. Contemporary colours reflect the latest trends in vehicle colouring but are subject to deletion.

*Metallic paint is an option, at extra cost.

Ford Transit Base Chassis Cab
Tomy cloth seat trim in Lichen



Ford Transit Base Chassis Cab
York Weave vinyl trim in Lichen (Option, not Double Cab)

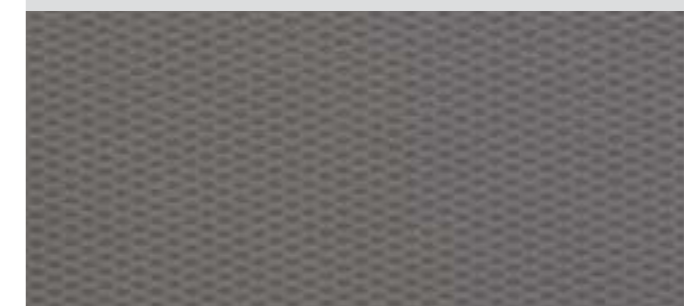

Note The images used are to illustrate body colours only and may not reflect the vehicle described. Colours and trims reproduced within this brochure may vary from the actual colours, due to the limitations of the printing processes used.

Illustrations, descriptions and specifications. This brochure was correct at the time of going to print. However, Ford policy is one of continuous product development. The right is reserved to change specifications, colours and prices of the models and items illustrated and described in this publication at any time. For the latest details always consult your Ford Dealer. **Optional equipment.** Throughout this publication, wherever a feature is described as being an 'Option' or 'Optional Fitment/Pack', etc., you should assume that it will be at extra cost to the base vehicle, unless specifically stated to the contrary. **All models and colour combinations are subject to availability. Note.** Some images portrayed are of a pre-production model and/or are computer generated, therefore, the design/features on the final version of the vehicle may differ in various respects. In addition, some of the features shown on the vehicles may be optional. **Note.** This brochure contains both original Ford accessories as well as a range of carefully selected products from our suppliers, which are featured under their own brands. **All supplier branded products are subject to warranty terms defined by the relevant suppliers and do not lie within the responsibility of Ford. Note.** The Bluetooth® word mark and logos are owned by the Bluetooth SIG, Inc. and any use of such marks by Ford Motor Company is under licence. Other trademarks and trade names are those of their respective owners.

The Government fuel figures do not express or imply any guarantee of the fuel consumption of any particular car. The cars themselves have not been tested and there are inevitably differences between individual cars of the same model. In addition, a car may incorporate particular modifications. Furthermore, the driver's style and road and traffic conditions, as well as the extent to which the car has been driven and the standard of maintenance, will affect its fuel consumption. **Insurance groups** are only as recommended by the Association of British Insurers. You should always consult your insurance adviser for confirmation.



BY APPOINTMENT TO
HER MAJESTY THE QUEEN
MOTOR VEHICLE MANUFACTURERS
FORD MOTOR COMPANY LIMITED
BRENTWOOD ESSEX



BY APPOINTMENT TO
HER MAJESTY THE PRINCE OF WALES
MOTOR VEHICLE MANUFACTURERS
FORD MOTOR COMPANY LIMITED
BRENTWOOD ESSEX



Collect Nectar points at participating Ford Dealers now. So keep a look out for the latest Ford offers at www.ford.co.uk/nectar or call the Ford Information Service on 0845 7111 888. Calls are charged at national rate and may be recorded for training purposes.



Ford recommends BP.



When you have finished with this brochure please recycle it.

Published by Commercial Vehicle Marketing,
Ford Motor Company Limited,
Brentwood, Essex, England.
Registered in England No. 235446.
FA 1553/2
BJN 306309. FoE H49E.
PN 977517/0909/15.7m/GBR en.
September 2009.
© Ford Motor Company Limited.

www.ford.co.uk

Transit Chassis Cab
driver delivered materials
here