

**Ford**TransitVan

Feel the difference





## Obsession is a good thing

Do you mind that your new Ford commercial vehicle is a result of minuscule design improvements to make it more efficient?

Do you mind that we carried out extreme tests of reliability? (Such as 250,000 door slams on the same door.)

Do you mind that we dedicated hundreds of thousands of hours working out how to reduce your cost of ownership?

Do you mind that 300 specialist engineers tested every single component in your vehicle?

We think obsession is a good thing when you build commercial vehicles. If you drive one, you probably agree with us.

**Style with substance**

The right image is essential for any business. But style is nothing without substance. So the Ford Transit is far more than simply an attractive face. Beneath the bold and stylish surface you will find all the indisputable factors that have made it the most respected van in its class.

For more information, please visit: [www.fordvans.co.uk](http://www.fordvans.co.uk)

**Model:** Transit LWB 3.2L 200PS high roof **Options:** appearance pack, fog lamps and metallic paint, all at extra cost



**Model:** Transit Limited.  
**Options:** Sony CD/radio with DAB audio system and passenger airbag, both at extra cost.

### Move your business on

Some people work in an office. Others are always on the move. Now the Ford Transit lets you take your office with you, wherever you're heading. The comfortable car-like cab boasts superbly thought-out features, like an A4 hanging file in the glovebox, two covered storage trays, two cup holders, two 2L bottle holders and a useful foldable work surface. Add satellite navigation or the latest Bluetooth® wireless technology to the list of attributes, and your life on the road will take on a completely new direction.



**Model:** Trend SWB low roof  
**Options:** metallic paint (no charge option on Trend, Limited), rear glazed tailgate (at extra cost)

### Loads better

Long or tall, big or small, light or heavy, the Ford Transit Van range can carry it all. With three wheelbases, three roof heights, four body lengths and the choice of front-, rear- and even all-wheel drive available, there is a variant for any type of hard work. Across the range, you will find full-height rear doors that open through 180° to reveal a generous load area with space to carry 8'x 4' building boards vertically or horizontally and effortless Europallet loading. A sliding side load door, flat load platform, tie-down eyes and minimal wheel arch intrusion all enhance Transit's loadspace efficiency.





Vehicle shown with load compartment protection kit (Option on Transit and Trend at extra cost, standard on Limited)

**Side cargo storage rail**  
Allows loads to be easily and securely lashed. (Option – load strap not supplied. Shown with load compartment trim board)



A practical load box is your number-one priority and the hallmark of the Ford Transit Van.

## Load compartment

Near-vertical body sides translate into a hugely usable loadspace. So too does the width between the rear wheel arches, which is amongst the greatest of any vehicle in its class. Together they provide enough room to load standard 8' x 4' building boards either horizontally or on their sides in the short wheelbase van. Or up to five Europallets in the single rear wheel LWB EL 'Jumbo'.

Because you need to reach your cargo during the working day, we've made it as easy as possible to load and unload. Twin unglazed rear doors are fitted as standard, along with a passenger's sliding side load door. A driver's side load door is also available.

Your Ford Transit Specialist Dealer can supply and fit a wide range of accessories to optimise your van, together with arranging the fitment of racking or other load box fixtures to your specification.

For more specific uses, Ford Special Vehicle Options (SVO) are available to meet unique customer requirements. For further details, please speak to your local Ford Transit Specialist Dealer.

### Key benefits

- Four body length choices
- Low, medium and high roof heights (all-steel construction)
- 100 mm lower load floor on front-wheel drive models
- Minimal taper of load box sides for maximum usable loadspace
- 1390 mm width between rear wheel arches (single rear wheel models)
- Rear doors check at 90° and can be opened to 180° at the press of a button, 256° on 'Jumbo' models
- Magnetic door retainers on 256° opening doors ('Jumbo')
- Wide range of loadspace and Ford Special Vehicle Options available.

**Over-cab storage area**  
Available on medium and high roof models. (Option)

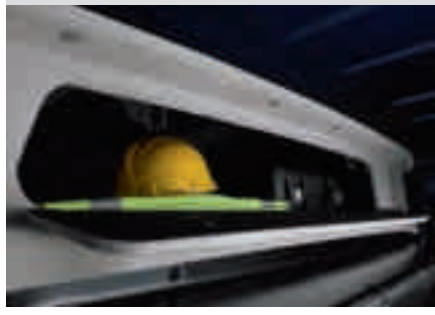

**Twin sliding side load doors**  
For improved side load access. (Option, standard on FWD MWB low roof)



**Tie-down eyes**  
Allow loads to be fixed securely. Complying with DIN 75410 specification. (Standard)



**Rear centre step**  
Improves access into the rear loadspace. (Option)



**Tailgate**  
Available on low roof models. (Option) (SVO option available for medium roof)



**Rear doors**  
180° opening unglazed rear (Standard)  
256° opening doors (Standard on 'Jumbo', option on other models)





**Model:** Trend LWB high roof  
**Option:** metallic paint (no charge option on Trend, Limited)

**Unglazed rear doors and full-height steel bulkhead**  
 Standard to form a secure steel load box.



As a business user, you need to have confidence in your vehicle. So the Ford Transit can take plenty of tough treatment.

## Safety and Security

It's tough on the streets. So the Ford Transit is endowed with end-to-end strength to command respect when tangling with city traffic. Plus award-winning security for your precious load and the most comprehensive safety package in the business. New technology makes it an even more secure place to work with the availability of a number of options including Cat 1 alarm, slam locking and configurable unlocking that allows you to choose which doors to unlock, and in which order.

Transit is consistently recognised as one of the leaders for security. From its PATS immobiliser and high security shielded locks, to its optional range of alarms; Transit offers a comprehensive portfolio of proven security technology.

### Key safety features available include:

- Hill Launch Assist\* – prevents the vehicle rolling back when pulling away on a slope
- Driver's airbag
- Outer front passenger's airbag and side airbags (Options)♦
- Three-point seat belts on all seats
- ISOFIX child seat mounting points in the second row centre and outer passenger positions (DCIV only)

### Key security features available include:

- Ford Safeguard Passive Anti-Theft System (PATS) Thatcham Category 2 approved engine immobiliser
- High-security shielded locks with strengthened mountings
- Key-locking bonnet
- 'Torque slip' anti-theft steering wheel
- Remote central double-locking
- Visible VIN (Vehicle Identification Number)

### Optional security features include:

- **Slam locking** – a useful option that allows the cargo doors to lock immediately when the door is slammed closed provided the vehicle has been locked using the remote key fob. Especially convenient for delivery and collection drivers.
- **Configurable unlocking** – this optional feature allows the driver to choose which doors to unlock, and in which order, when selected buttons are pressed on the remote key fob. This provides added confidence, particularly for delivery operators.
- **Perimeter alarm** – with trailer monitoring alarm. The system monitors all cab and loadspace doors for unauthorised entry. The trailer coupling is also monitored and the alarm activates if unauthorised trailer removal is detected.
- **Thatcham Category 1 alarm** features interior scanner to detect glass breakage and an independent battery back-up in case the vehicle battery supply is interrupted.

**Self-charging waterproof key fob**  
 So the key will not let you down – when you need it most! (Standard)

**Occupant safety**  
 Driver's airbag (Standard) Large-volume passenger♦ and seat-mounted side, head and thorax airbags (Options)

\*Note: A rear-facing child seat should never be placed in the front passenger seat when the Ford vehicle is equipped with an operational front passenger's airbag. Standard on AWD models.

\*ESP / HLA is not available on all-wheel drive or petrol engine models.

**Steel bulkhead with full width recess**  
 DIN 75410 compliant. (Standard on MWB, LWB and LWB EL. Option on SWB)

**Steel bulkhead with driver recess**  
 DIN 75410 compliant. (Standard on SWB. Option on other wheelbases)

**Steel bulkhead with glazed window**  
 DIN 75410 compliant. (Option)

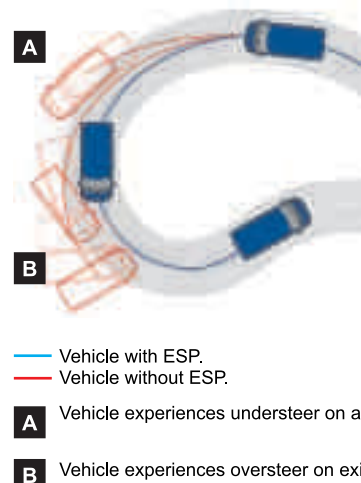

### Electronic Stability Programme\*

Electronic Stability Programme (ESP) incorporating ABS, senses when the vehicle is deviating from the driver's chosen line and automatically applies the necessary power and braking adjustments to correct its road position.

### Brake Traction Control System (BTCS)

Aids traction when starting from rest.

### Hill Launch Assist (HLA)

Prevents the vehicle from rolling backwards when pulling away on a slope.

### Brake Assist

A system that detects emergency braking and automatically applies maximum braking effort to potentially reduce the stopping distance.



### **Serious business**

Commercial vehicle running costs are a serious consideration for every business. At Ford, we're obsessive about this key area of ownership – and it results in a range of new Ford commercial vehicles that are more economical to run and more dependable than ever before.

## 10 ways a new Ford saves you money

### **1. Further between fill-ups**

Fuel is the single biggest expense for many commercial vehicle operators. In addition to designing commercial vehicles that are as fuel-efficient as possible, we're adding new features that make them easier to drive in an economical style.

### **2. Going the extra mile(s)**

Proper maintenance is vital to good fuel economy and a long service life. But we know you want your van to be out on the road earning its keep – so we never stop looking for new ways of increasing the time and distance you can cover between routine services.

### **3. Passionate about what we do**

We're dedicated to developing the most hard-working and efficient commercial vehicles that money can buy. This is why we scrutinise every detail of every design – no matter how small – to see if even the most minuscule improvements can be found.

### **4. There when you need us**

No one knows your Ford better than the Ford-trained technicians throughout our extensive Dealer network. In addition, European Roadside Assistance comes as standard with your new Ford commercial vehicle.

### **5. Today and tomorrow**

We offer a range of fixed-cost servicing, extended warranty, and roadside assistance plans that mean continued worry-free operation. We can tailor warranty packages to suit a variety of requirements, extending your coverage year by year or for a fixed time period.

### **6. Real-world thinking**

Sometimes the small things can make all the difference. Transit's rechargeable and waterproof key fob means no expense and inconvenience of getting a new remote-control battery. Likewise, mounting the lockable spare wheel under the vehicle's load area and the jack in the front footwell allow quick, easy tyre changes.

### **7. Testing, testing, testing...**

We leave nothing to chance. We're relentless. Every component in a Ford commercial vehicle has been rigorously tested by over 300 specialist engineers at our state-of-the-art Lommel Proving Ground in Belgium with its 80 km of test road.

### **8. A new milestone**

Ford Transit passed another milestone in 2010, when the six-millionth example of this iconic vehicle rolled off the production line. The past 45 years have been an amazing ride – and everyone at Ford is looking forward to the next 45 being just as exciting.

### **9. Making finance easy**

Ford Credit and Ford Insure make purchasing, leasing and insuring your commercial vehicle easy and affordable. Ford Acquire provides flexible repayment terms and deposit levels. Ford Business Partner can look after everything from maintenance and repairs to accident management, so you can concentrate on your business. And Ford Credit even lets you manage your account online.

### **10. Driving down your fuel bill**

Rising fuel prices mean we're all feeling the pinch at the pumps. You may be surprised to hear that small changes to your driving style could cut your fuel bill by as much as 20 per cent – while helping the environment, too!

**Transit**



**Model:** Transit Double Cab-in-Van LWB high roof  
**Options:** (at extra cost) metallic paint, dual side load doors, AWD.

**Digital tachograph**  
 Sets new standards for performance, technology, design and tamper-proofing. (May be a legal requirement on some variants)



The Ford Transit Van's advanced diesel engine range features the latest common-rail fuel-injection technology.

## Power you can count on

Our line-up of Duratorq TDCi diesel engines uses advanced design and technology to boost performance and efficiency. The latest common-rail fuel-injection system helps to give a hard-working combination of horsepower and torque for superior load carrying and towing capability. There's also a 2.3 Duratec 145 PS petrol engine available for rear-wheel drive applications, which is compatible with LPG (subject to conversion by a third-party specialist).

### Emission Legislation

All Transit engines currently comply with stage IV emissions legislation. And now, if you choose Econetic with the coated Diesel Particulate Filter, you will comply with the more stringent stage V legislation which calls for reductions of 28% NO<sub>x</sub> and 92% particulates when compared with stage IV levels.

### Pulling power

For some operators, towing is an everyday way of life; for others, it is an occasional event. With up to 470 Nm of torque available, and maximum Gross Train Mass (GTM) ranging from 3500 kg to 6500 kg\*, the Ford Transit is thoughtfully designed to cope with whatever demands you make.

\*Depending on engine, transmission and final drive ratio.

### 3.2 Duratorq TDCi engine

Developing an impressive 200 PS and a mighty 470 Nm of peak torque, the 3.2-litre 5-cylinder Duratorq TDCi is one of the most powerful diesel engines in its class. Available for 350 and 460 RWD models, it comes coupled to a 6-speed manual transmission.

### Long-range fuel tank

The 103-litre fuel tank offers an extra 23 litres capacity over the standard tank for less frequent fuel stops, saving you both time and money. Available on rear wheel drive models (except short wheelbase).

### All-wheel drive

When the going gets tough, trust Ford Transit's advanced electronically-controlled all-wheel drive system to see you through with ease. Available with the 140 PS Duratorq TDCi engine – coupled to a 6-speed manual transmission – it is the ideal choice when extra traction is required in poor driving conditions, such as snow, rain, mud or gravel.

### Energy Management

Rear-wheel drive, all-wheel drive and 330/350 front wheel drive models are equipped with twin batteries as standard (option on 260/280/300 front wheel drive).

This arrangement allows the second battery to power whatever accessory is needed when the engine is switched off, leaving the primary battery in a high state of charge for dependable start and run operation.

## Together we can care for the environment

Thanks to smart ideas and clever refinements, Ford's advanced technology is creating cleaner, more fuel-efficient vehicles today.

### We're working to reduce your costs

From the latest ECONetic models to 6-speed manual transmissions; coated Diesel Particulate Filters to revised final drive ratios, our affordable technologies are providing benefits to the environment – and your pocket.

Other initiatives, such as speed limiters and a gearshift indicator light, provide a helpful aid to using less fuel, and encourage a smoother driving style.

### Ford ECONetic series

Ford ECONetic brings you a range of vehicles that are as fuel efficient as possible today, without compromising their practicality or your driving experience.

With their optimised engines and transmissions, you can benefit from the best possible CO<sub>2</sub> performance, coupled with excellent fuel economy, low cost of ownership and when the cDPF is also specified, compliance with stage V emission standards,

### A sustainable future

Ford vehicles are among the most environmentally efficient on the road, but our commitment to a sustainable future reaches far beyond our model range and into other areas of operation.

Across Europe, many of our facilities now receive their electricity from renewable sources, including wind, solar, hydro and waste generation, helping to further reduce our carbon footprint.

#### Speed limiter

Available on all diesel models and standard on ECONetic. Can help to reduce fuel bills.

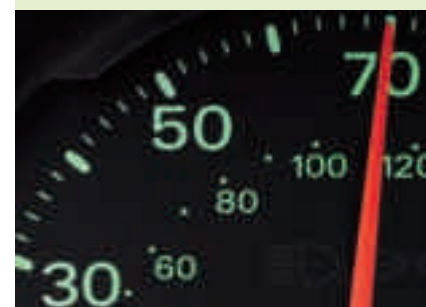

#### Ford ECONetic

Low CO<sub>2</sub> Ford ECONetic technology is now available on Ford Transit.



#### Taking a leading role in recycling

Increasing vehicle recyclability when they reach the end of their useful life.



#### Shift indicator light

Tells you the optimum time to change gear for fuel efficiency (Available on all diesels)



#### Coated diesel particulate filter (cDPF)

Maintenance-free cDPF reduces exhaust particulate emissions. (Available on all diesel models)



#### Award-winning eco plant

Our Dagenham Diesel Centre (UK) derives all its electricity from renewable sources.





In short wheelbase form, the Ford Transit Van is ideal for urban driving, providing excellent manoeuvrability. Its exceptionally practical load box will accommodate standard 8' x 4' building boards or up to three Europallets, while the Double Cab-in-Van version offers up to 5.20/3.94 cu.m\* of loadspace and seating for six.

## Short wheelbase

### SWB Van

- 2582 mm load length
- From 864 kg to 1555 kg gross payload
- From 6.05/5.19 cu.m to 7.94/6.81 cu.m loadspace\*
- Choice of FWD (low floor), RWD or AWD
- Choice of low roof or medium roof
- Ability to carry standard 8' x 4' building boards horizontally or on their sides
- Space for up to three 1.2 m x 0.8 m Europallets
- Turning circle (kerb to kerb) 10.8 m



### Double Cab-in-Van

The Ford Double Cab-in-Van is a great solution for moving people and their equipment at the same time.

Available in all four body lengths from short wheelbase to 'Jumbo' there is a double cab size to suit all applications.

The passenger area has a second row of factory-fitted seats to accommodate a crew of up to six, including the driver, in comfort and safety.

Access to the rear is via the glazed side load door, while the fully secured load box ensures that tools and equipment are out of view while the vehicle is parked on site. A second, right-hand side load door is available as an option at extra cost.

### SWB Double Cab-in-Van

- 1654 mm load length
- From 759 kg to 1000 kg gross payload
- Up to 5.20/3.94 cu.m loadspace\*
- FWD (low floor) only
- Choice of low roof or medium roof
- Three extra seats and full width bulkhead as standard

\*Measured using the SAE/VDA method and measured in cubic metres.

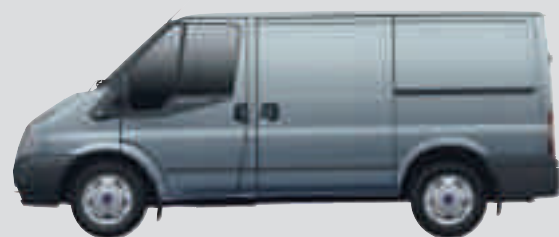

SWB low roof van.

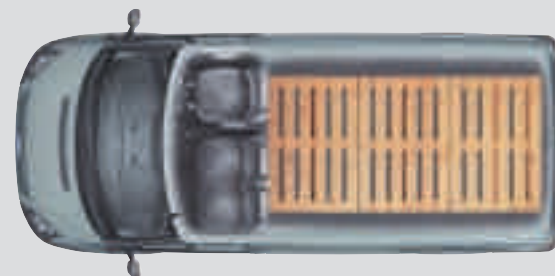

Three 1.2 m x 0.8 m Europallets.



SWB Double Cab-in-Van low roof.



SWB medium roof van.



SWB Double Cab-in-Van Medium Roof.

Boasting three different roof heights the medium wheelbase Ford Transit Van is an extremely accommodating choice, including the versatile low roof version, which gives greater loadbox functionality for longer loads (vs. SWB) whilst still allowing access to height restricted areas.

## Medium wheelbase

### Ford Transit Van MWB versus SWB

- 367 mm longer load length
- Greater loadspace capacity
- Higher and wider side load door
- Higher maximum payload capability
- Choice of three roof heights

### Ford Transit Van MWB

- 2949 mm load length
- From 964kg to 1677 kg gross payload
- From 7.44/6.45 cu.m to 10.31/8.85 cu.m loadspace\*
- Choice of FWD (low floor), RWD (standard floor) or AWD
- Choice of low roof, medium roof or high roof
- Space for up to four 1.2 m x 0.8 m Europallets.
- Turning circle (kerb to kerb) 11.9 m

### MWB Double Cab-in-Van

- 1893 mm load length
- From 859 kg to 1399 kg gross payload
- Up to 6.80/5.21 cu.m loadspace\*
- Choice of FWD (low floor), RWD (standard floor) or AWD
- Choice of low roof, medium roof or high roof
- Three extra seats and full width bulkhead as standard



\*Measured using the SAE/VDA method and measured in cubic metres.



MWB low roof van.

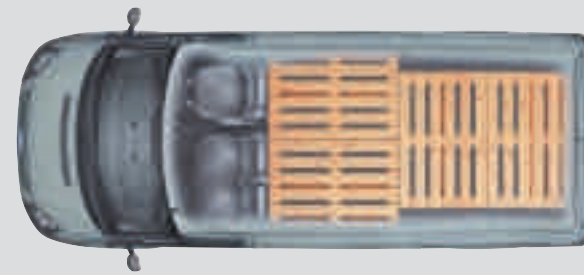

Four 1.2 m x 0.8 m Europallets.



MWB Double Cab-in-Van Low Roof.



MWB medium roof van.



MWB Double Cab-in-Van medium roof.



MWB high roof van.



MWB Double Cab-in-Van High Roof.



For maximum loadspace, look no further than the long wheelbase Ford Transit Van and the vastly accommodating 'Jumbo' van; both ideally suited to fast highway deliveries of heavy or bulky goods. There's now a 4.6 tonne GVM version for those operators who regularly carry the largest loads and a 350HD (Heavy Duty) version for operators demanding greater loading latitude from a 3.5 tonne GVM van.

## Long wheelbase and 'Jumbo' Van

### Ford Transit Van LWB versus MWB

- 450 mm longer load length
- Greater loadspace

### Ford Transit Van LWB

- 3399 mm load length
- From 940 kg to 1586 kg gross payload
- From 9.85/8.45 cu.m to 11.89/10.20 cu.m loadspace\*
- Choice of FWD (low floor), RWD (standard floor) or AWD
- Choice of medium roof or high roof
- Space for up to four 1.2 m x 0.8 m Europallets
- Turning circle (kerb to kerb) 13.3 m

### LWB Double Cab-in-Van

- 2506 mm load space
- From 940 kg to 1372 kg gross payload
- Up to 8.10/6.56 cu.m loadspace\*
- Choice of FWD (low floor) or RWD (standard floor)
- Choice of medium roof or high roof
- Can accommodate 8'x 4' building boards (RWD only)
- Three extra seats and full width bulkhead as standard

### Ford Transit 'Jumbo' Van, single rear wheel (350)

- 4107 mm load length
- 14.30/12.28 cu.m loadspace\*
- Up to 1318 kg gross payload
- Space for up to five Europallets
- Rear-wheel drive, high roof configuration
- 256° opening doors with magnetic retainers
- Turning circle (kerb to kerb) 13.3 m

### Ford Transit 'Jumbo' Van, dual rear wheels (350HD, 460)

- 4107 mm load length
- 14.30/12.28 cu.m loadspace\*
- Up to 2265 kg gross payload
- Space for up to four Europallets
- Rear-wheel drive, high roof configuration
- 256° opening doors with magnetic retainers
- Turning circle (kerb to kerb) 13.3 m

### 'Jumbo' Double Cab-in-Van (350)

- 3229 mm load length
- 10.80/9.31 cu.m loadspace\*
- Up to 1210 kg gross payload
- Rear-wheel drive, high roof configuration
- Three extra seats and full width bulkhead as standard



\*Measured using the VDA method and measured in cubic metres.

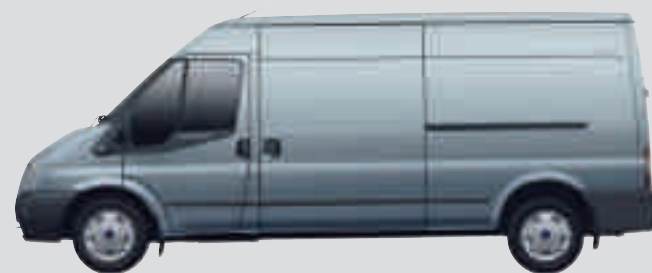

LWB medium roof van.



Four 1.2 m x 0.8 m Europallets.



LWB 'Jumbo' dual rear wheel van.



Four 1.2 m x 0.8 m Europallets.

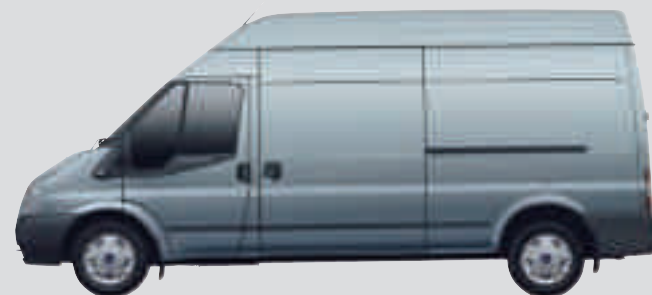

LWB high roof van.



LWB 'Jumbo' single rear wheel van.



Five 1.2 m x 0.8 m Europallets.

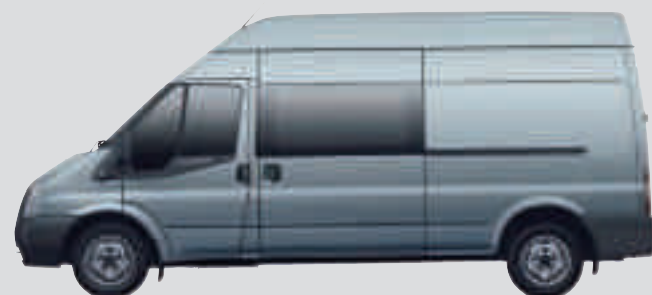

LWB Double Cab-in-Van high roof/ LWB EL 'Jumbo' SRW Double Cab-in-Van high roof.



LWB 'Jumbo' double cab-in-van high roof.

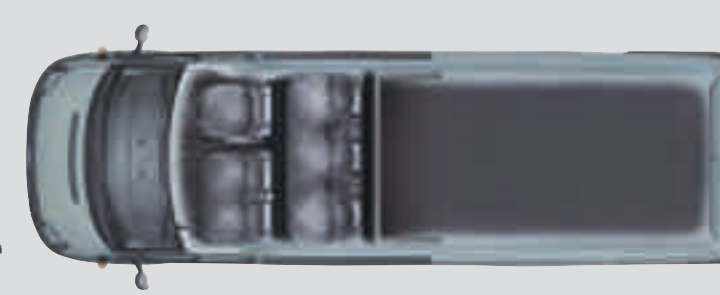



## Driven by the way you work

The power to deliver a top-quality job is the key to success in any business. So our comprehensive range of engines, transmissions and drivetrains has been developed to withstand the rigours of working life.

### Why front-wheel drive?

- Lower load floor for easier loading and unloading
- Larger loadspace and extra interior height
- Outstanding manoeuvrability and driving feel
- Better fuel economy and payload than equivalent RWD models
- Ideal choice for multi-drop delivery applications

### Diesel (FWD)

2.2 Duratorq TDCi engine, available in three power and torque configurations:

- 85 PS/250 Nm
- 115 PS/300 Nm
- 140 PS/350 Nm

### Transmissions

- Durashift 5-speed manual transmission (85 PS TDCi diesel)
- Durashift 6-speed manual transmission (115 PS/140 PS TDCi diesel)

Diesel (FWD)

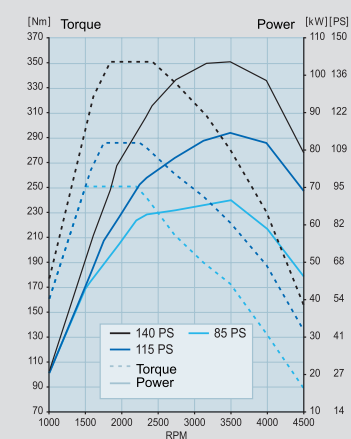

### Why rear-wheel drive?

- Traditional layout for heavier duty applications
- Ideal choice when towing
- Superior traction under power, particularly when laden
- Enhanced steering quality

### Petrol (RWD)

2.3 Duratec engine (LPG\*\* compatible)

- 145 PS/210 Nm

### Transmission

- Durashift 5-speed manual transmission

### Diesel (RWD)

2.4 Duratorq TDCi engine, available in three power and torque configurations:

- 100 PS/285 Nm
- 115 PS/310 Nm
- 140 PS/375 Nm

3.2 Duratorq TDCi 5-cylinder engine:

- 200 PS/470 Nm

### Transmissions

- Durashift 5-speed manual transmission (100 PS TDCi diesel \*)
- Durashift 6-speed manual transmission

\*replaced by 6-speed Autumn 2010

Diesel (RWD)

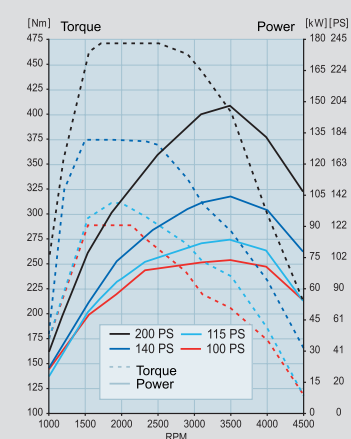

### Why all-wheel drive?

- Additional traction in difficult driving conditions, such as loose surfaces or heavy snow
- 'Intelligent' automatic system – requires no driver input
- Under normal conditions drive is directed to just the rear wheels. In slippery conditions, the system increases drive to the front wheels to enhance traction
- Suited for rescue services or utility companies where field and track work is frequently undertaken

### Diesel (AWD)

2.4 Duratorq TDCi engine:

- 140 PS/375 Nm

### Transmission

- Durashift 6-speed manual transmission

Diesel (AWD)

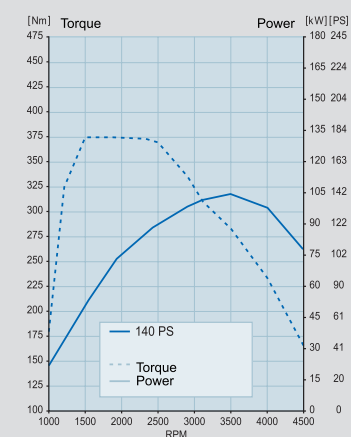

# Transit ECOnetic

Reduce your running costs – and your carbon footprint – with the Ford Transit ECOnetic. Powered by a specially calibrated 2.2-litre 115 PS/300 Nm Duratorq TDCi engine, it returns a combined 39.2 mpg\*, with best-in-class CO<sub>2</sub> emissions of 189 g/km average, without compromising Transit's legendary load-carrying performance.

### Key exterior features

- SWB/FWD body style
- Longer gearing – 4.36:1 final drive ratio with 16" wheels
- 6 speed manual transmission
- 70 mph speed limiter
- Full wheel covers
- 6-speed manual transmission
- Stage V emission compliant model available, includes coated Diesel Particulate Filter (cDPF)

### Key Interior features

- Shift indicator light – unique calibration with earlier illumination for more efficient gear changes
- Engine mapping – optimised for fuel efficiency
- Trip Computer

### Restrictions

- Medium roof
- Dual side load doors
- Load area protection kit
- Alloy wheels
- Mud and snow tyres
- 56 and 62 mph speed limiters
- Rear floor mat/load compartment protection kit
- 750 kg towing limit



# Transit Van

The Ford Transit Van's cab is remarkably well equipped for the most affordable model in the range. Its superbly designed instrument panel and generous stowage features reinforce the high level of quality and craftsmanship to be found throughout the entire vehicle.



## Exterior features

- Tinted glass
- Electrically-operated windows
- Remote central locking
- Front and rear mudflaps

## Interior features

- Model 6000 RDS stereo radio/CD player with auxiliary MP3 connector and steering column-mounted controls
- Driver's and passenger's side facia-top stowage compartments with lids
- 12-volt power point on driver's side
- Central storage for A4 binder or clipboard
- Passenger's side open storage bin
- Centre-mounted car park /toll ticket holder
- Facia-mounted swivelling tray with two cup holders and pen slot
- Glovebox with rails designed to take A4 hanging files
- Two 2-litre bottle holders
- Driver's side door pocket
- Height-adjustable passenger seat belt
- Heater with air recirculation feature
- Full-width DIN 75410 compliant steel bulkhead
- Shift Indicator Light (SIL)

## Option packs available:

### Trunker Pack

- Cruise control
- Trip Computer

### Visibility Pack

- Quickclear heated windscreen
- Electrically-operated and heated door mirrors

### Premium Visibility Pack

- Quickclear heated windscreen
- Electrically-operated and heated door mirrors
- Automatic headlights
- Rain-sensing front wipers
- Instrument panel dimmer
- Front fog lamps

### Appearance Pack

- Body colour grille and front bumper centre piece
- Wheel covers (single rear wheel models only)
- Bodyside mouldings (not available on Jumbo models)
- Front fog lamps



# Trend Van

With its stylish exterior, well-equipped cab and flexible loadspace, Ford Transit Trend Van is the perfect way to mix business with pleasure. Not only does it look good, but with its advanced Bluetooth® connectivity and generous stowage space, it can serve as a genuine mobile office too.



## Exterior features additional to Transit Van

- Full wheel covers
- Front fog lights
- Body colour grille and front bumper centre section
- Stainless steel front bumper step plate
- Black bodyside mouldings
- Remote central locking with two key fobs
- Metallic paint (no charge option)

## Interior features additional to Transit Van

- Leather-wrapped steering wheel with silver-effect spokes
- Leather gearshift knob
- Cruise control
- Trip computer
- Bluetooth® wireless connectivity, offering voice control for the audio system and most compatible mobile phones
- Loadspace trim boards
- Quickclear heated windscreen
- Electrically-operated and heated door mirrors
- Automatic headlights
- Rain-sensing front wipers
- Instrument panel dimmer

Note The Bluetooth® word mark and logos are owned by Bluetooth SIG, Inc. and any use of such marks by Ford Motor Company Limited and its associated companies is under licence. Other trademarks and trade names are those of their respective owners.



## Limited Van

Distinguished by stylish alloy wheels and a superbly-equipped cab, the Ford Transit Limited Van is quite simply the ultimate professional's work vehicle.



### Exterior features additional to Trend Van

- 16" 5-spoke alloy wheels

### Interior features additional to Trend Van

- Air conditioning
- 10-way adjustable, heated driver's seat with armrest
- Kado velour seat trim
- Perimeter alarm
- Load area protection kit\*

\*Kit contents include: \*MDF rear trim and full-length rubber mat  
Interior shown features optional satellite navigation system at extra cost





# Sport Van

Ford Transit Sport Van makes a bold statement about you and your business. With dynamic 18" alloy wheels, low-profile 235/45 tyres<sup>1</sup>, wide bonnet stripes, twin exhaust pipes and muscular styling enhancements\*, it wouldn't look out of place on a racetrack. SportVan is only available as part of a targeted, limited production run.



## Exterior features

- 18" graphite<sup>2</sup> alloy wheels with 235/45 tyres\*<sup>1</sup>
- Front/rear lower spoilers with bright front centre section\*
- Side skirts
- Extended wheel arches\*
- Wide bonnet stripes\*
- Duratorq TDCi 140 PS engine
- Premium Visibility Pack<sup>4</sup>
- Twin exhaust tailpipes\*
- Remote locking with two key fobs
- Body side mouldings

## Interior features

- Model 6006 RDS radio/6-disc CD player or Sony radio/CD with DAB<sup>2</sup>
- Auxiliary MP3 connector
- Steering column-mounted controls
- Air conditioning
- 10-way adjustable, heated driver's seat with armrest
- Kado velour seat trim
- Cruise control and trip computer
- Load area protection kit<sup>5</sup>
- Outer front passenger's airbag<sup>6</sup>

<sup>1</sup> Please note: 18" low profile sport tyres may possibly have shorter service lifetime compared with standard light truck tyres, depending on load and driving conditions. For more information, please speak to your local Ford Transit Specialist Dealer.

<sup>2</sup> Colorado red SportVan, graphite wheels and Sony Radio/CD with DAB audio system available from Autumn 2010. Sony audio system and graphite wheels will be fitted as standard on Colorado red SportVan, earlier vehicles will be fitted with 6006 6CD audio system. Interior image shows Sony audio system.

<sup>3</sup> Images show rear parking sensors and step (optional, at extra cost)  
<sup>4</sup> Please note: Accessories supplied by MS Design. All supplier-branded components are subject to the warranty terms defined by the relevant supplier and do not lie within the responsibility of Ford.

<sup>5</sup> Pack contents include: Quickclear heated windscreen; electrically-operated and heated door mirrors; automatic headlights; rain-sensing front wipers; instrument panel dimmer; front fog lights; and stainless steel front bumper step plate.

<sup>6</sup> Kit contents include: MDF rear trim; full-length rubber mat; and load compartment tie-down loops.

<sup>7</sup> Note: A rear-facing child seat should never be placed in the front passenger seat when the Ford vehicle is equipped with an operational front passenger's airbag.

### Twin exhaust pipes

Distinctive styling enhances the van's appearance.<sup>3</sup>



### Express delivery

The Ford Transit Sport Van has a winning capacity for practicality and hard work.<sup>3</sup>





When your vehicle is an integral part of your business, it's important to have the freedom to tailor its specification exactly to your needs. So, with our extensive range of accessories, you'll find everything from mudflaps and tow bars to the latest satellite navigation systems. Each item has been specially developed to enhance both the efficiency and image of your business.

## Accessories

**Image left shows:** Rear window protection grille, ClimAir® wind deflector, rear ladder, wide bodyside mouldings, base roof carrier with Thule Professional roof carrying system, mudflaps, stainless steel side protection bars and 16" alloy wheels\*. (Options and accessories) Please speak to your Ford Transit Specialist Dealer for more details.

### Parking Distance System

Prevent collision damage and protect your investment with this set of four sensors. (Accessory)

### Tow bar

Can tow up to 1,200 kg, depending on engine. (Option and accessory) Choose between 7-pin or 13-pin electrical kit. (Option and accessory)

Model shown is finished in Moon dust Silver metallic paint. (Option)

**Note** The Bluetooth® word mark and logos are owned by the Bluetooth SIG, Inc. and any use of such marks by Ford Motor Company Limited and its associated companies is under licence. Other trademarks and trade names are those of their respective owners.

**Note** It is an offence for drivers to use a hand-held mobile phone or similar device while driving.

\*Supplied by MS Design. Please note that all supplier-branded accessories are provided with a supplier's warranty and are subject to the supplier's warranty terms. Such accessories are, therefore, excluded from the Ford warranty.

### Rear window protection grilles

Grilles secure to inside of rear windows for additional security without obscuring rearward vision. (Accessory, not available with optional tailgate)



### Air suspension kit

Additional air suspension on the rear axle lets you easily adjust vehicle ride height to safely carry heavy or unbalanced loads. (Accessory)



### Loadspace liner

Heavy-duty liner helps to protect your load floor from accidental damage. (Accessory for SWB and MWB vans)



### Waeco bottle cooler

With the MyFridge bottle cooler there's always a cool drink at hand. Whatever you fancy, the compact cooler keeps 1 to 1.5 litres of your favourite drink up to 22°C below the ambient temperature. And it will even keep things warm, up to 60°C. (Accessory)



### Daytime LED running light

For improved visibility on the road and a unique extra touch of style. (Accessory – MS Design)

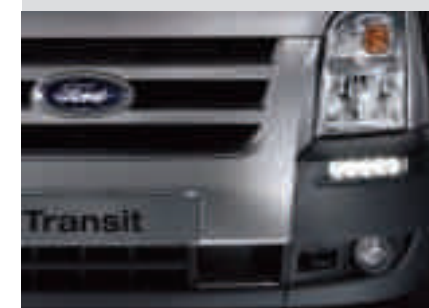

### Rear view camera

Cab-mounted 7" LCD colour display monitors the area behind the vehicle. Used in conjunction with the exterior mirrors, the camera provides peace of mind when reversing, day or night, especially in busy locations. Transit Van only. (Accessory)



### Climair® Wind Deflectors

These wind deflectors minimise turbulence, letting you enjoy your drive with the windows open - even when it's raining. (Accessory)



### Parrot Bluetooth® hands-free kits

These Bluetooth® hands-free kits connect via the factory-fitted audio system. Shown is the Parrot MKi9200 with 2.4" colour TFT screen, built-in voice recognition and automatic phone-book synchronisation. (Accessory)



### Portable navigation

Leave your maps behind with a simple and intuitive portable GPS navigation system. Please contact your Ford Dealer for details. (Accessory)



We are all beginning to understand the impact that mobility is having on climate change. While we can't change things overnight, we are working very hard to find solutions.

### Making a difference now

Our latest range of engines complies with Euro Stage IV regulations. Duratorq TDCi diesel engines now develop more torque whilst delivering lower emissions. On Transit models, our Duratec 2.3L engine can be converted to run on liquefied petroleum gas (LPG) or compressed natural gas (CNG).

In the Ford car range, our optional Flexifuel engine is achieving emission reductions of around 30% to 80%\*\* compared to conventional petrol engines.

### Protecting the future

Using our Product Sustainability Index, a design for sustainability management tool, we are addressing the environmental, social and economic impacts of our vehicles from the earliest stages of their development\*.

We are working on a wide range of vehicle technologies from biofuels to hybrids and clean diesels, and in the long term to hydrogen fuel-cell technology with the potential for near zero CO<sub>2</sub> emissions.

### Improving our manufacturing facilities

We are constantly working to minimise the impact of our facilities on the environment. This includes pioneering on-site generation of electricity from sun and wind, implementing leading-edge manufacturing processes and full certification to the international standard for Environmental Management Systems; ISO 14001. This has led to improved environmental performance through savings in energy, water, material and waste-handling requirements.

### Recycling for good

In the interests of sustainability, many of our components contain recycled and renewable content. All Ford vehicles are at least 85% recyclable and 95% recoverable in accordance with ISO 22628. We offer free take-back for qualifying vehicles at the end of their lives. All our take-back points are fully licensed and must also meet additional Ford quality standards for the professional receipt, treatment and recovery of end-of-life vehicles.

This brochure has been produced on paper based on fibres from sustainable forestry, using a 100% chlorine-free (TCF) bleaching process.

\*For more about this topic, see <http://www.ford.com/en/company/about/sustainability/2006-07/downloads.htm>

\*\*Dependent on feedstock used and production process. (Source: EUCAR CONCAWE study.) Ford supports the sustainable production of biofuels.



Programme for the Endorsement of Forest Certification schemes

This brochure is printed on PEFC certified paper promoting sustainable forest management.

Our range of finance, insurance, service and assistance options is designed with just one thing in mind – making life easy for you.

## Ford Credit

Your Ford Transit Specialist Dealer can offer simple, plain language advice on the various ways of financing your purchase. They can help you complete an application and get a decision, usually within 15 minutes. For further details, visit [www.ford.co.uk](http://www.ford.co.uk) or contact your Ford Transit Specialist Dealer.

**Ford Acquire** is a straightforward way to own your vehicle. Simply put down a deposit, pay the remainder, plus interest, over an agreed period and the vehicle becomes yours.

**Ford Business Partner** Contract Hire<sup>†</sup> provides an affordable, convenient and flexible way to finance your business vehicle.

**Ford Insure\*** is our comprehensive motor insurance product, designed specifically for Ford drivers.

Finance subject to status. **Business Users only.** Guarantees/Indemnities may be required. Freeport Ford Credit.

<sup>†</sup>Business Partner Contract Hire is provided by Lex Vehicle Leasing Limited, trading as Ford Business Partner, Heathside Park, Heathside Park Road, Stockport SK3 0RB.

\*Ford Insure is underwritten and administered by Royal & Sun Alliance Insurance plc (No. 93792), Registered in England and Wales at St. Mark's Court, Chart Way, Horsham, West Sussex, RH12 1XL. Authorised and regulated by the Financial Services Authority. For your protection, telephone calls may be recorded and monitored.

## Services

There are 222 Sales and 245 Aftersales Ford Transit Specialist Dealers across the UK, equipped and trained to meet Commercial Vehicle customer requirements. From these, 113 Sales and 95 Aftersales Dealers have achieved the 'Backbone standard' as recognition of their total commitment to delivering dedicated and professional sales and service support.

To find the location of your nearest Ford Transit Specialist Dealer, simply call the Ford Information Service on **0845 7111 888**, or visit the Ford Dealer locator at **[www.fordvans.co.uk](http://www.fordvans.co.uk)**

**Ford Protect** Every new Ford Fiesta Van is protected by a 3-year/60,000-mile Ford Protect Classic Warranty Plan, and also comes with a 1-year Ford Assistance package.

Ford Ranger is protected by a 3-year/60,000 mile Ford Protect Classic Warranty Plan

Ford Transit and Transit Connects are protected by a 3-year/100,000-mile bumper-to-bumper warranty.

Ford Transit Chassis Cab One-Stop bodywork is covered by a 3-year/100,000-mile warranty and a 3-year Perforation Warranty provided by the bodywork supplier.

**Ford Perforation Warranty** Every new Ford Fiesta Van, Transit and Transit Connect is covered by the Ford Perforation Warranty for 8 years<sup>9</sup> from the date of first registration. Ranger is covered for 6 years from the date of first registration.

**Ford Assistance** Ford Transits, Transit Connects and Rangers are supplied with a minimum of a 1-year Ford Assistance roadside package. Further details are available either on [www.ford.co.uk](http://www.ford.co.uk) or from your local Ford Dealer.

**Ford Rapid Fit** Our 'no appointments necessary, while-you-wait' fast-fit service for exhausts, brakes, batteries and more, at over 240 sites nationally.

**Ford Accident Repair Centres** Approved Ford Accident Repair Centres meet rigorous Ford standards and are the best place to return your vehicle to its pre-accident condition.

## Contacts

**Ford Customer Relationship Centre** In the unlikely event that your Ford Dealer can't help you or if you need to speak to us directly, call 0845 841 1111 at local rates.

**Ford Rental - local service nationwide** Car and van rental from our latest model range. Contact your local Ford Dealer for more information.

**Talkback - the company car drivers' club** This is your club for extended test drives, special events, and advice on tax and buying issues. Join free, even if you don't drive a Ford, on [www.talkbackclub.com](http://www.talkbackclub.com) or call 0845 605 55 66.

**Ford Mobility** Our MAGIC care centre provides free information on all motoring and mobility issues, including special offers for HRDLA and Motability recipients. Call free on 0800 240 241.

<sup>9</sup>Subject to terms and conditions.

# Ford Range

Ford Transit Minibus

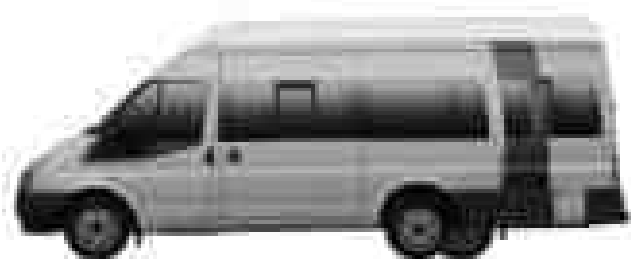

Ford Transit Van



Ford Double Cab-in-Van

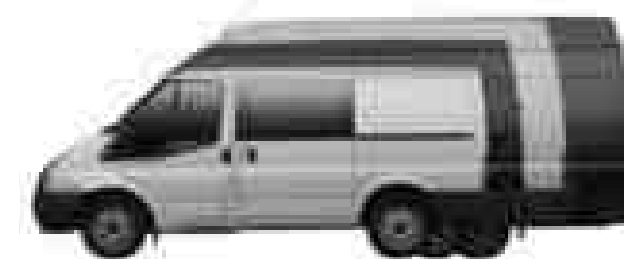

Ford Tourneo

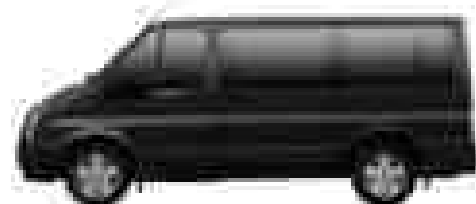

Ford Tourneo Connect



Ford Transit Connect Van



Ford Fiesta Van



	Seats	Wheelbase	Overall length (mm)	Overall height (mm)	Overall width (mm) <sup>†</sup>
Ford Tourneo Connect	5 and 8	LWB	4525	1981	2044
Ford Tourneo	8 and 9	SWB	4863	1989-2070	2374
Ford Transit Minibus	9 and 12	MWB	5230	2302-2363	2374
	14 and 15	LWB	5680	2393	2374
	17 Med. Roof	LWB EL	6403	2380	2374
	17 High Roof	LWB EL	6403	2624	2374

<sup>†</sup>Includes mirrors.

	Wheelbase	Load length (mm)	Cube (cu.m)	Payload (gross)** (kg)	Gross Vehicle Mass (kg)	Maximum Gross Train Mass (kg)
Ford Fiesta Van	SWB	1320	1.013	493-513	1490-1550	2090-2285
Ford Fiesta SportVan	SWB	1320	1.013	492-495	1550	2300
Ford Transit Connect Van	SWB	1760 <sup>‡</sup> -2467 <sup>‡‡</sup>	2.8 <sup>‡</sup> -3.4 <sup>‡‡</sup>	624-829	2040-2240	2840-3040
	LWB	2007 <sup>‡</sup> -2714 <sup>‡‡</sup>	3.7 <sup>‡</sup> -4.3 <sup>‡‡</sup>	884-888	2340	3140
Ford Transit Connect Crew van	SWB	909	1.4	708-718	2240	3040
	LWB	1172	2.1	751-755	2340	3140
Ford Transit Van	SWB	2582	6.55-7.94	864-1555	2600-3300	3500-5300
	MWB	2949	7.44-10.31	964-1677	2800-3500	3500-6300
	LWB	3399	9.85-11.89	940-1586	3000-3500	4500-6300
	LWB EL 'Jumbo'	4107	14.30	1146-2265	3500-4600	5500-6500
Ford Transit Double Cab-in-Van	SWB	1654	4.20-5.20	759-1000	2600-2800	3500
	MWB	1893	4.80-6.80	859-1399	2800-3500	3500-6300
	LWB	2349* -2506**	7.10-8.50	832-1372	3000-3500	4500-6300
	LWB EL 'Jumbo'	3229	10.80	1099-1210	3500-4600	5500-6500

\*\*Gross payload = GVM minus kerbweight. <sup>‡</sup> With passenger's seat upright. <sup>‡‡</sup> With passenger seat folded. \*FWD. \*\*RWD.

Ford Transit Chassis Cabs

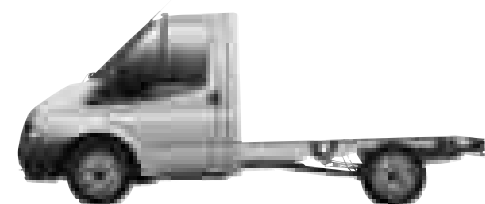

Ford Transit Chassis Double Cabs

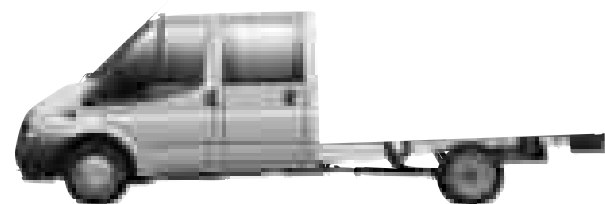

	Nominal body length	Wheelbase	Payload (gross)** (kg)	Gross Vehicle Mass (kg)	Maximum Gross Train Mass (kg)
Ford Chassis Cab	2.85m (9ft 4in)	SWB	1308-1444	3000	3500-5000
	3.2m (10ft 6in)	MWB	1660-2724	3500-4600	6000-6500
	3.66m (12ft 0in)	LWB	1653-1731	3500-4600	6000-6500
	4.0m (13ft 1in)	LWB EF	1530-2669	3500-4600	6000-6500
Ford Chassis Double Cab	2.85m (9ft 4in)	LWB	1457-2596	3500-4600	6000-6500
	3.2m (10ft 6in)	LWB EF	1482-2588	3500-4600	6000-6500

\*\*Gross payload = GVM minus kerbweight.

Ford Ranger

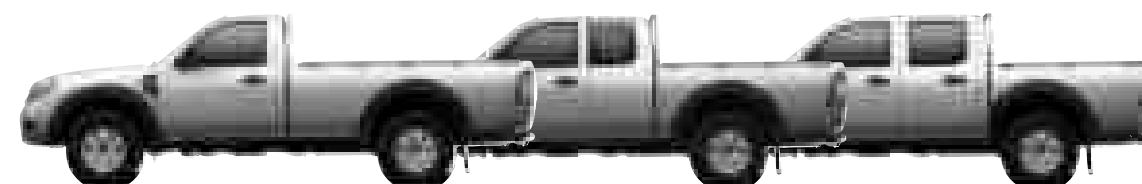

	Drive	Load box length (mm)	Load box width (mm)	Payload (gross)** (kg)	Gross Vehicle Mass (kg)	Maximum Gross Train Mass (kg)
Ford Ranger Regular Cab	4x2/4x4	2280	1456	1190/1235	2800/3010	4400/6010
Ford Ranger Super Cab	4x2/4x4	1753	1456	1225/1225	2885/2995	4485/5995
Ford Ranger Double Cab	4x4	1530	1456	1175	2995	5995

\*\*Gross payload = GVM minus kerbweight.

### Ford Transit Van SWB Low Roof

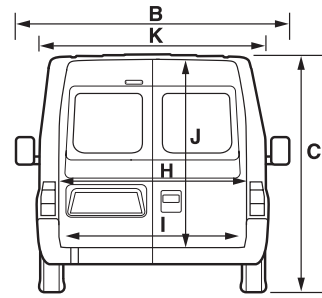
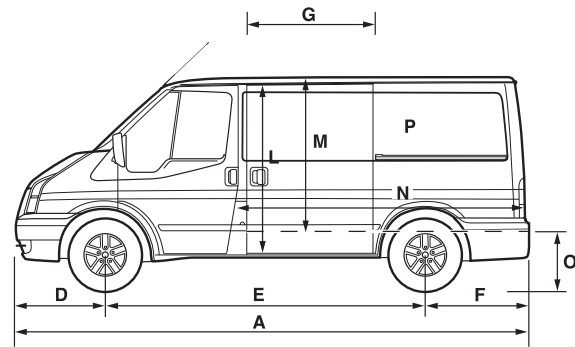

### Ford Transit Van SWB Medium Roof

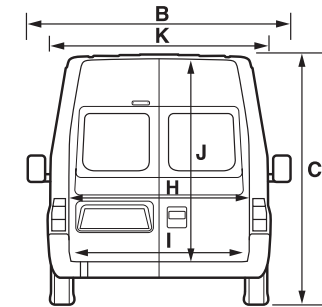
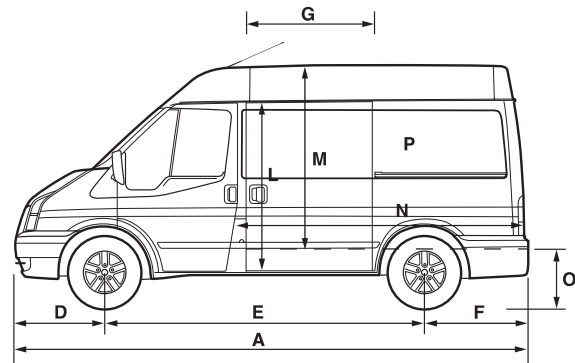

### Ford Transit Double Cab-in-Van SWB Low Roof

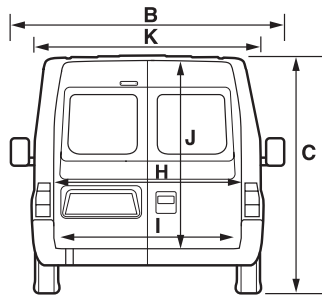
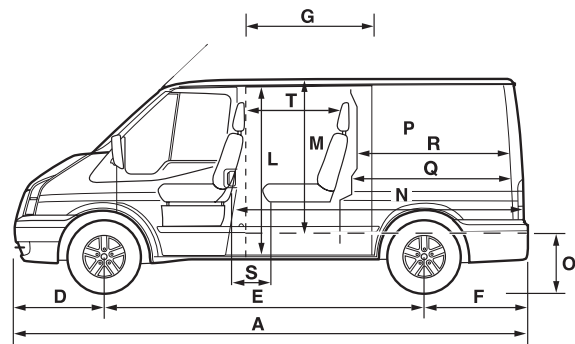

### Ford Transit Double Cab-in-Van SWB Medium Roof

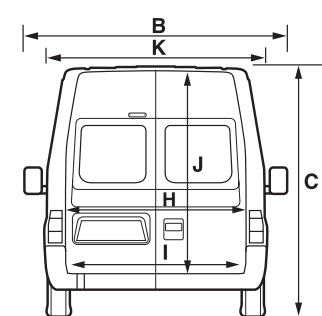
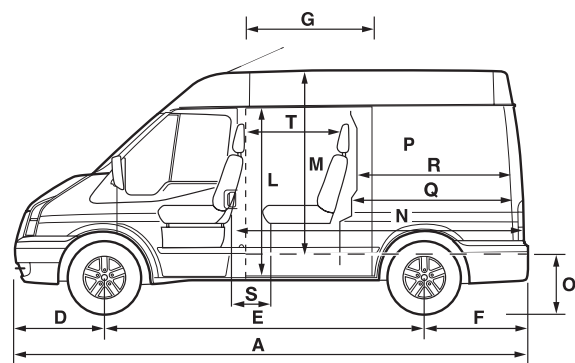

### Dimensions (mm)

	SWB Low Roof Van		SWB Medium Roof Van	
	Front-Wheel Drive	Rear-Wheel Drive	Front-Wheel Drive	Rear-Wheel Drive
<b>A</b> Overall length (excluding step where fitted)	4863	4863	4863	4863
<b>B</b> Overall width (with/without mirrors)	2374/1974	2374/1974	2374/1974	2374/1974
<b>C</b> Overall height	1997-2067	2082-2089	2313-2383	2398-2405
<b>D</b> Front of vehicle to front wheel centre	933	933	933	933
<b>E</b> Wheelbase	2933	2933	2933	2933
<b>F</b> Rear of vehicle to rear wheel centre	997	997	997	997
<b>G</b> Side door entry width	1030	1030	1030	1030
<b>H</b> Rear door entry width	1540	1540	1540	1540
<b>I</b> Loadspace between wheel arches	1390	1390	1390	1390
<b>J</b> Rear door entry height	1370	1270	1666	1566
<b>K</b> Maximum loadspace width	1762	1762	1762	1762
<b>L</b> Side load door entry height	1352	1252	1600	1500
<b>M</b> Load floor to roof	1430	1330	1745	1645
<b>N</b> Maximum loadspace length	2582	2582	2582	2582
<b>O</b> Loading height	537-609	725-732	538-609	725-732
<b>P</b> Loadspace	6.55/5.62 (cu.m)	6.05/5.19 (cu.m)	7.94/6.81 (cu.m)	7.48/6.42 (cu.m)
<b>Double Cab-in-Van unique measurements</b>				
<b>P</b> Loadspace (SAE only)	4.2 (cu.m)	–	5.2 (cu.m)	–
<b>Q</b> Maximum loadspace length	1654	–	1654	–
<b>R</b> Minimum loadspace length	1500	–	1500	–
<b>S</b> Second row seating – leg clearance	240	–	240	–
<b>T</b> Second row seating – head restraint to head restraint	700	–	700	–
<b>Turning Circle (m)</b>				
Kerb to kerb	10.8	10.8	10.8	10.8
Wall to Wall	11.4	11.4	11.4	11.4

**Key:** All dimensions (shown in mm) are subject to manufacturing tolerances and refer to minimum specification models and do not include additional equipment. \*Height dimensions show the range from minimum to maximum of a fully laden, lowest payload vehicle to unladen highest payload vehicle. These illustrations are for guidance only. Loadspace shown as SAE/VDA and measured in cubic metres. **VDA method** This is the method used by the Verbund die Automobil Industrie (VDA) in Germany. A VDA figure is determined by filling the loadspace with 'litre' blocks, each measuring 200x100x50 mm. The blocks are then counted, and the numerical result is converted into cubic metres. **SAE method** The SAE (Society of Automotive Engineers) method simply measures the volume of a fine-grained material such as sand or rice which can be deposited into the loadspace. **Ford** favours the use of the more realistic VDA method of calculation for measuring 'useable' interior loadspace.

## Weights and loads

	Driveline	Gross vehicle mass (kg)	Kerb mass (kg)*	Gross payload (kg) <sup>o</sup>	Front axle plated mass (kg)	Rear axle plated mass (kg)	Front axle kerb mass (kg)	Rear axle kerb mass (kg)	Axle ratio <sup>oo</sup>	Max. GTM (kg) with quoted axle ratio
<b>260 SWB Low Roof Van</b>										
2.2 TDCi 85 PS	FWD	2600	1699	901	1450	1475	1095	604	4.23	3500
2.2 TDCi 115 PS	FWD	2600	1708	892	1450	1475	1104	604	4.36	3500
2.2 TDCi 140 PS / Sport	FWD	2600	1710	890	1450	1475	1106	604	4.36	3500
<b>280 SWB Low Roof Van</b>										
2.2 TDCi 85 PS	FWD	2800	1699	1101	1450	1650	1095	604	4.23	3500
2.2 TDCi 115 PS	FWD	2800	1708	1092	1450	1650	1104	604	4.36	3500
2.2 TDCi 115 PS ECOnetic	FWD	2840	1743	1097	1450	1650	1116	627	4.36	3500
2.2 TDCi 140 PS	FWD	2800	1710	1090	1450	1650	1106	604	4.36	3500
<b>300 SWB Low Roof Van</b>										
2.2 TDCi 85 PS	FWD	3000	1699	1301	1600	1760	1095	604	4.23	3500
2.2 TDCi 115 PS	FWD	3000	1708	1292	1600	1760	1104	604	4.36	3500
2.2 TDCi 140 PS	FWD	3000	1710	1290	1600	1760	1106	604	4.36	3500
2.4 TDCi 140 PS	<b>AWD</b>	3000	2038	962	1700	1850	1223	815	4.27	5000
<b>330 SWB Low Roof Van</b>										
2.2 TDCi 115 PS	FWD	3300	1745	1555	1700	2150	1117	628	4.93	5300
2.2 TDCi 140 PS	FWD	3300	1748	1552	1700	2150	1119	629	4.93	5300
2.4 TDCi 100 PS 5 Speed**	RWD	3300	1924	1376	1700	2150	1137	787	4.78/5.11	5300
2.4 TDCi 100 PS 6 Speed**	RWD	3300	1892	1408	1700	2150	1119	773	3.73/4.27	5300
2.4 TDCi 115 PS	RWD	3300	1892	1408	1700	2150	1119	773	3.73/4.27	5300
2.4 TDCi 140 PS	RWD	3300	1958	1342	1700	2150	1152	806	3.73/4.27	5300
2.4 TDCi 140 PS	<b>AWD</b>	3300	2038	1262	1700	2150	1223	815	4.27	5300
2.3 P 145 PS	RWD	3300	1872	1428	1700	2150	1081	791	5.11/5.44	4500/5000
<b>260 SWB Low Roof Double Cab-in-Van</b>										
2.2 TDCi 85 PS	FWD	2600	1807	793	1450	1475	1132	675	4.23	3500
2.2 TDCi 115 PS	FWD	2600	1816	784	1450	1475	1141	675	4.36	3500
<b>280 SWB Low Roof Double Cab-in-Van</b>										
2.2 TDCi 85 PS	FWD	2800	1800	1000	1450	1650	1132	675	4.23	3500
2.2 TDCi 115 PS	FWD	2800	1800	1000	1450	1650	1141	659	4.36	3500
2.2 TDCi 140 PS	FWD	2800	1800	1000	1450	1650	1143	676	4.36	3500

## Weights and loads

	Driveline	Gross vehicle mass (kg)	Kerb mass (kg)*	Gross payload (kg) <sup>o</sup>	Front axle plated mass (kg)	Rear axle plated mass (kg)	Front axle kerb mass (kg)	Rear axle kerb mass (kg)	Axle ratio <sup>oo</sup>	Max. GTM (kg) with quoted axle ratio
<b>260 SWB Medium Roof Van</b>										
2.2 TDCi 85 PS	FWD	2600	1724	876	1450	1475	1099	625	4.23	3500
2.2 TDCi 115 PS	FWD	2600	1733	867	1450	1475	1109	624	4.36	3500
2.2 TDCi 140 PS	FWD	2600	1736	864	1450	1475	1111	625	4.36	3500
<b>280 SWB Medium Roof Van</b>										
2.2 TDCi 85 PS	FWD	2800	1724	1076	1450	1650	1099	625	4.23	3500
2.2 TDCi 115 PS	FWD	2800	1733	1067	1450	1650	1109	624	4.36	3500
2.2 TDCi 140 PS	FWD	2800	1736	1064	1450	1650	1111	625	4.36	3500
<b>300 SWB Medium Roof Van</b>										
2.2 TDCi 85 PS	FWD	3000	1724	1276	1600	1760	1099	625	4.23	3500
2.2 TDCi 115 PS	FWD	3000	1733	1267	1600	1760	1109	624	4.36	3500
2.2 TDCi 140 PS	FWD	3000	1736	1264	1600	1760	1111	625	4.36	3500
2.4 TDCi 140PS	<b>AWD</b>	3000	2064	936	1700	1850	1228	836	4.27	5000
<b>330 SWB Medium Roof Van</b>										
2.2 TDCi 115 PS	FWD	3300	1771	1529	1700	2150	1122	649	4.93	5300
2.2 TDCi 140 PS	FWD	3300	1773	1527	1700	2150	1124	649	4.93	5300
2.4 TDCi 100 PS 5 Speed**	RWD	3300	1949	1351	1700	2150	1142	807	4.78/5.11	5300
2.4 TDCi 100 PS 6 Speed**	RWD	3300	1964	1336	1700	2150	1154	810	3.73/4.27	5300
2.4 TDCi 115 PS	RWD	3300	1964	1336	1700	2150	1154	810	3.73/4.27	5300
2.4 TDCi 140 PS	RWD	3300	1983	1317	1700	2150	1157	826	3.73/4.27	5300
2.4 TDCi 140 PS	<b>AWD</b>	3300	2064	1236	1700	2150	1228	836	4.27	5300
2.3 P 145 PS	RWD	3300	1898	1402	1700	2150	1086	812	5.11/5.44	4500/5000
<b>260 SWB Medium Roof Double Cab-in-Van</b>										
2.2 TDCi 85 PS	FWD	2600	1833	767	1450	1475	1136	697	4.23	3500
2.2 TDCi 115 PS	FWD	2600	1841	759	1450	1475	1146	695	4.36	3500
<b>280 SWB Medium Roof Double Cab-in-Van</b>										
2.2 TDCi 85 PS	FWD	2800	1833	967	1450	1650	1136	697	4.23	3500
2.2 TDCi 115 PS	FWD	2800	1841	959	1450	1650	1146	695	4.36	3500
2.2 TDCi 140 PS	FWD	2800	1844	956	1450	1650	1148	696	4.36	3500

**SWB** = Short wheelbase. **FWD** = Front-wheel Drive. **RWD** = Rear-wheel Drive. **Gross Payload** = Gross vehicle mass, less kerb mass. **GVM** = Gross vehicle mass. The total permissible all-up weight of a rigid vehicle – i.e. with body, payload, ancillaries, fuel, oil, water, driver and crew. **Kerb mass** = The weight of the complete vehicle and all equipment including fuel and water, but without payload, driver or any crew. All kerb masses quoted in this brochure are subject to manufacturing tolerances and are for vehicles with minimum equipment. **GTM** = Gross train mass. The total permissible all-up weight of a rigid vehicle (see GVM) together with its trailer and load. <sup>oo</sup>The illustrated rear axle ratio shown is one example of what is available dependent upon model, payload and engine combination. Alternative ratios are available, in most cases, for more specialised applications. Different GTMs available with alternative rear axle ratios. Please consult your Ford Dealer for details. **\*\*6-speed** replaces 5-speed from autumn 2010.

Ford Transit Van MWB Low Roof

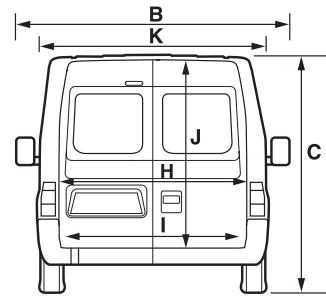
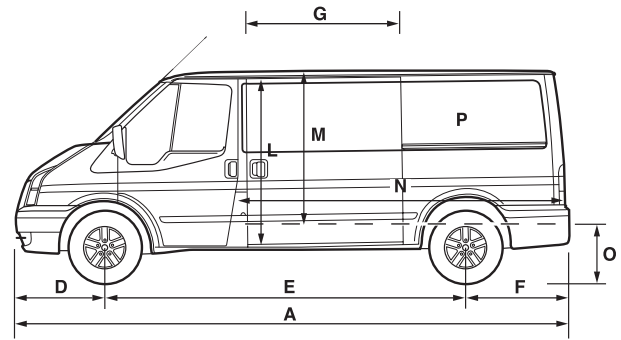

Ford Transit Double Cab-in-Van MWB Low Roof

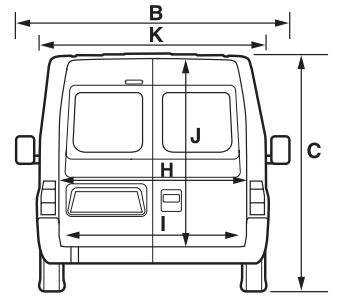
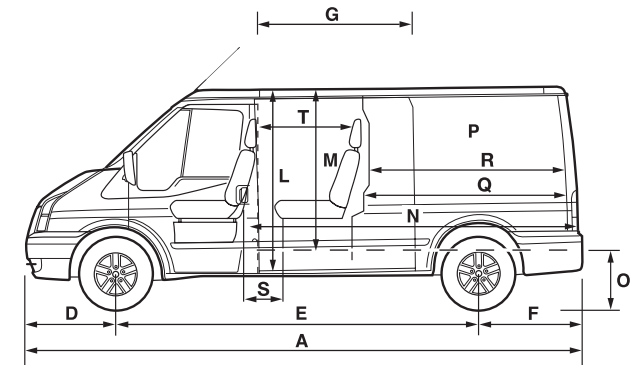

Ford Transit Van MWB Medium Roof

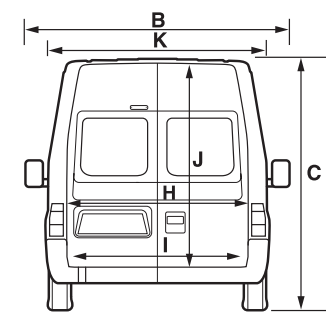
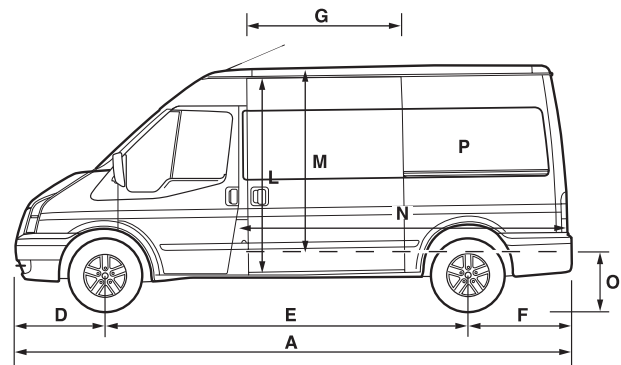

Ford Transit Double Cab-in-Van MWB Medium Roof

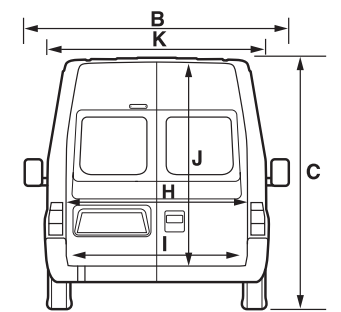
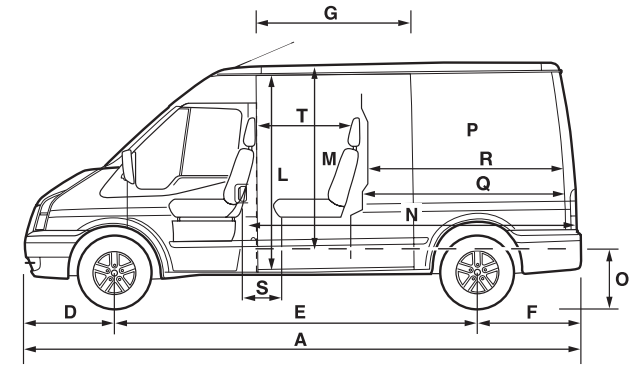

Ford Transit Van MWB High Roof

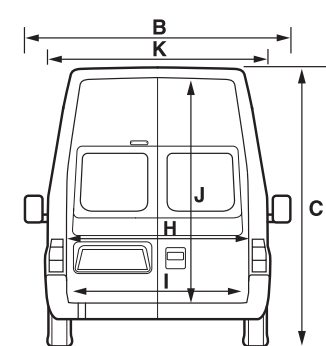
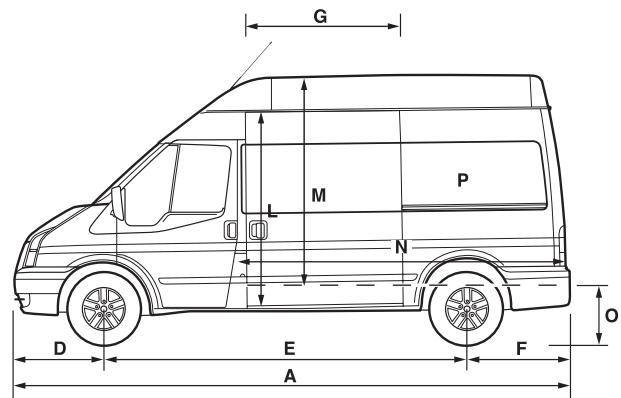

Ford Transit Double Cab-in-Van MWB High Roof

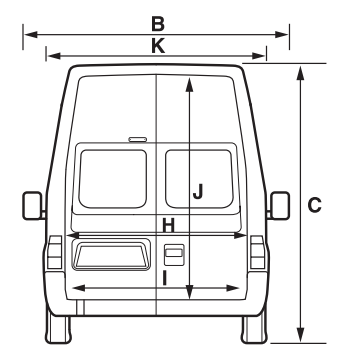
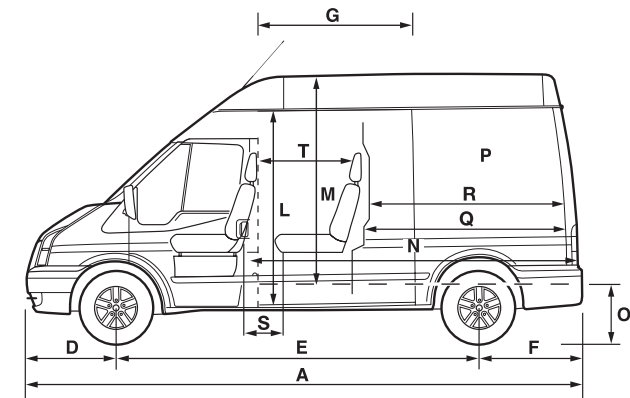

## Dimensions (mm)

		MWB Low Roof Van Front-Wheel Drive	MWB Medium Roof Van Front-Wheel Drive    Rear-Wheel Drive	MWB High Roof Van Front-Wheel Drive    Rear-Wheel Drive	
<b>A</b>	Overall length (excluding step where fitted)/length 3.2L 200PS	5230	5230	5230/5301	5230    5230/5301
<b>B</b>	Overall width (with/without mirrors)	2374/1974	2374/1974	2374/1974	2374/1974
<b>C</b>	Overall height	1985-2056	2310-2371	2374-2390	2546-2601    2604-2620
<b>D</b>	Front of vehicle to front wheel centre/length 3.2L 200PS	933	933	933/1004	933    933/1004
<b>E</b>	Wheelbase	3300	3300	3300	3300
<b>F</b>	Rear of vehicle to rear wheel centre	997	997	997	997
<b>G</b>	Side door entry width	1250	1250	1250	1250
<b>H</b>	Rear door entry width	1540	1540	1540	1540
<b>I</b>	Loadspace between wheel arches	1390	1390	1390	1390
<b>J</b>	Rear door entry height	1370	1666	1566	1896    1796
<b>K</b>	Maximum loadspace width	1762	1762	1762	1762
<b>L</b>	Side load door entry height	1352	1600	1500	1600    1500
<b>M</b>	Load floor to roof	1430	1745	1645	1985    1885
<b>N</b>	Maximum loadspace length	2949	2949	2949	2949
<b>O</b>	Loading height	535-596	535-596	699-715	541-596    699-715
<b>P</b>	Loadspace	7.44/6.45 (cu.m)	9.07/7.78 (cu.m)	8.55/7.34 (cu.m)	10.31/8.85 (cu.m)    9.79/8.40 (cu.m)
<b>Double Cab-in-Van unique measurements</b>					
<b>P</b>	Loadspace (SAE only)	4.8	6.0	5.7	6.8    6.5
<b>Q</b>	Maximum loadspace length	1893	1893	1893	1893
<b>R</b>	Minimum loadspace length	1740	1740	1740	1740
<b>S</b>	Second row seating – leg clearance	370	370	370	370
<b>T</b>	Second row seating – head restraint to head restraint	830	830	830	830
<b>Turning Circle (m)</b>					
	Kerb to kerb	11.9	11.9	11.9	11.9
	Wall to wall	12.5	12.5	12.5	12.5

**Key:** All dimensions (shown in mm) are subject to manufacturing tolerances and refer to minimum specification models and do not include additional equipment. \*Height dimensions show the range from minimum to maximum of a fully laden, lowest payload vehicle to unladen highest payload vehicle. These illustrations are for guidance only. Loadspace shown as SAE/VDA and measured in cubic metres. **VDA method** This is the method used by the Verbund die Automobil Industrie (VDA) in Germany. A VDA figure is determined by filling the loadspace with 'litre' blocks, each measuring 200x100x50 mm. The blocks are then counted, and the numerical result is converted into cubic metres. **SAE method** The SAE (Society of Automotive Engineers) method simply measures the volume of a fine-grained material such as sand or rice which can be deposited into the loadspace. **Ford** favours the use of the more realistic VDA method of calculation for measuring 'useable' interior loadspace.

## Weights and loads

	Driveline	Gross vehicle mass (kg)	Kerb mass (kg)*	Gross payload (kg) <sup>o</sup>	Front axle plated mass (kg)	Rear axle plated mass (kg)	Front axle kerb mass (kg)	Rear axle kerb mass (kg)	Axle ratio <sup>oo</sup>	Max. GTM (kg) with quoted axle ratio
<b>280 MWB Low Roof Van</b>										
2.2 TDCi 85 PS	FWD	2800	1776	1024	1500	1650	1146	630	4.23	3500
2.2 TDCi 115 PS	FWD	2800	1785	1015	1500	1650	1156	629	4.36	3500
2.2 TDCi 140 PS	FWD	2800	1788	1012	1500	1650	1158	630	4.36	3500
<b>300 MWB Low Roof Van</b>										
2.2 TDCi 85 PS	FWD	3000	1776	1224	1600	1760	1146	630	4.23	4500
2.2 TDCi 115 PS	FWD	3000	1785	1215	1600	1760	1156	629	4.36	5200
2.2 TDCi 140 PS	FWD	3000	1788	1212	1600	1760	1158	630	4.36	5200
<b>330 MWB Low Roof Van</b>										
2.2 TDCi 115 PS	FWD	3300	1823	1477	1700	2150	1169	654	4.93	5500
2.2 TDCi 140 PS	FWD	3300	1826	1474	1700	2150	1171	655	4.93	5500
<b>350 MWB Low Roof Van</b>										
2.2 TDCi 115 PS	FWD	3500	1823	1677	1750	2250	1169	654	4.93	5500
2.2 TDCi 140 PS	FWD	3500	1826	1674	1750	2250	1171	655	4.93	5500
<b>280 MWB Low Roof Double Cab-in-Van</b>										
2.2 TDCi 115 PS	FWD	2800	1894	906	1500	1650	1198	696	4.36	3500
<b>300 MWB Low Roof Double Cab-in-Van</b>										
2.2 TDCi 115 PS	FWD	3000	1894	1106	1500	1650	1198	696	4.36	5200
<b>280 MWB Medium Roof Van</b>										
2.2 TDCi 115 PS	FWD	2800	1800	1000	1500	1650	1161	639	4.36	3500
2.2 TDCi 140 PS	FWD	2800	1800	1000	1500	1650	1163	637	4.36	3500
<b>300 MWB Medium Roof Van</b>										
2.2 TDCi 85 PS	FWD	3000	1802	1198	1600	1760	1152	650	4.23	4500
2.2 TDCi 115 PS	FWD	3000	1810	1190	1600	1760	1161	649	4.36	5200
2.2 TDCi 140 PS	FWD	3000	1813	1187	1600	1760	1163	650	4.36	5200
2.3 P 145 PS	RWD	3000	1939	1061	1600	1850	1119	820	5.11/5.44	4500
<b>330 MWB Medium Roof Van</b>										
2.2 TDCi 115 PS	FWD	3000	1848	1452	1700	2150	1174	674	4.23	5500
2.2 TDCi 140 PS	FWD	3300	1851	1449	1700	2150	1176	675	4.93	5500
2.4 TDCi 100 PS 5-speed**	RWD	3300	1993	1307	1700	2150	1178	815	4.78/5.11	5500/6000
2.4 TDCi 100 PS 6-speed**	RWD	3300	2007	1293	1700	2150	1190	817	3.73/4.27	5500/6000
2.4 TDCi 115 PS	RWD	3300	2007	1293	1700	2150	1190	817	3.73/4.27	5500/6000
2.4 TDCi 140 PS	RWD	3300	2027	1273	1700	2150	1193	834	3.73/4.27	6000/6100
<b>350 MWB Medium Roof Van</b>										
2.2 TDCi 115 PS	FWD	3500	1848	1652	1750	2250	1174	674	4.93	5500
2.2 TDCi 140 PS	FWD	3500	1851	1649	1750	2250	1176	675	4.93	5500
2.4 TDCi 100 PS 5-speed**	RWD	3500	1993	1507	1750	2250	1178	815	4.78/5.11	5500/6000
2.4 TDCi 100 PS 6-speed**	RWD	3500	2007	1493	1750	2250	1190	817	3.73/4.27	5500/6000
2.4 TDCi 115 PS	RWD	3500	2007	1493	1750	2250	1190	817	3.73/4.27	5500/6000
2.4 TDCi 140 PS	RWD	3500	2027	1473	1750	2250	1193	834	3.73/4.27	6000/6300
2.4 TDCi 140 PS	<b>AWD</b>	3500	2107	1393	1750	2250	1264	843	4.27	6300
3.2 TDCi 200 PS	RWD	3500	2103	1397	1750	2250	1263	840	3.58/4.10	6000/6300
<b>280 MWB Medium Roof Double Cab-in-Van</b>										
2.2 TDCi 115 PS	FWD	2800	1919	881	1500	1650	1203	716	4.36	3500
<b>300 MWB Medium Roof Double Cab-in-Van</b>										
2.2 TDCi 115 PS	FWD	3000	1919	1081	1600	1760	1203	716	4.36	5200



## Weights and loads

	Driveline	Gross vehicle mass (kg)	Kerb mass (kg)*	Gross payload (kg) <sup>o</sup>	Front axle plated mass (kg)	Rear axle plated mass (kg)	Front axle kerb mass (kg)	Rear axle kerb mass (kg)	Axle ratio <sup>oo</sup>	Max. GTM (kg) with quoted axle ratio
<b>350 MWB Medium Roof Double Cab-in-Van</b>										
2.4 TDCi 100 PS 5-speed**	RWD	3500	2101	1399	1750	2250	1219	882	4.78/5.11	5500/6000
2.4 TDCi 100 PS 6-speed**	RWD	3500	2116	1384	1750	2250	1232	884	3.73/4.27	5500/6000
2.4 TDCi 115 PS	RWD	3500	2116	1384	1750	2250	1232	884	3.73/4.27	5500/6000
2.4 TDCi 140 PS	RWD	3500	2135	1365	1750	2250	1235	900	3.73/4.27	6000/6300
2.4 TDCi 140 PS	<b>AWD</b>	3500	2216	1284	1750	2250	1305	911	4.27	6300
<b>280 MWB High Roof Van (Optional model)</b>										
2.2 TDCi 85 PS	FWD	2800	1824	976	1500	1650	1156	668	4.23	3500
2.2 TDCi 115 PS	FWD	2800	1833	967	1500	1650	1166	667	4.36	3500
2.2 TDCi 140 PS	FWD	2800	1836	964	1500	1650	1168	668	4.36	3500
<b>300 MWB High Roof Van (Optional model)</b>										
2.2 TDCi 85 PS	FWD	3000	1824	1176	1600	1760	1156	668	4.23	4500
2.2 TDCi 115 PS	FWD	3000	1833	1167	1600	1760	1166	667	4.36	5200
2.2 TDCi 140 PS	FWD	3000	1836	1164	1600	1760	1168	668	4.36	5200
2.3 Duratec Petrol 145 PS	RWD	3000	1962	1038	1600	1850	1124	838	5.11/5.44	4500
<b>330 MWB High Roof Van</b>										
2.2 TDCi 115 PS	FWD	3300	1870	1430	1700	2150	1179	691	4.93	5500
2.2 TDCi 140 PS	FWD	3300	1873	1427	1700	2150	1181	692	4.93	5500
2.4 TDCi 100 PS 5-speed**	RWD	3300	2015	1285	1700	2150	1182	833	4.78/5.11	5500/6000
2.4 TDCi 100 PS 6-speed**	RWD	3300	2030	1270	1700	2150	1195	835	3.73/4.27	5500/6000
2.4 TDCi 115 PS	RWD	3300	2030	1270	1700	2150	1195	835	3.73/4.27	5500/6000
2.4 TDCi 140 PS	RWD	3300	2049	1251	1700	2150	1198	851	3.73/4.27	6000/6100
<b>350 MWB High Roof Van</b>										
2.2 TDCi 115 PS	FWD	3500	1870	1630	1750	2250	1179	691	4.93	5500
2.2 TDCi 140 PS	FWD	3500	1873	1627	1750	2250	1181	692	4.93	5500
2.4 TDCi 100 PS 5-speed**	RWD	3500	2015	1485	1750	2250	1182	833	4.78/5.11	5500/6000
2.4 TDCi 100 PS 6-speed**	RWD	3500	2030	1470	1750	2250	1195	835	3.73/4.27	5500/6000
2.4 TDCi 115 PS	RWD	3500	2030	1470	1750	2250	1195	835	3.73/4.27	5500/6000
2.4 TDCi 140 PS	RWD	3500	2049	1451	1750	2250	1198	851	3.73/4.27	6000/6300
2.4 TDCi 140 PS	<b>AWD</b>	3500	2129	1371	1750	2250	1268	861	4.27	6300
3.2 TDCi 200 PS	RWD	3500	2126	1374	1750	2250	1267	859	3.58/4.10	6000/6300
<b>280 MWB High Roof Double Cab-in-Van</b>										
2.2 TDCi 115 PS	FWD	2800	1941	859	1500	1650	1208	733	4.36	3500
<b>300 MWB High Roof Double Cab-in-Van</b>										
2.2 TDCi 115 PS	FWD	3000	1941	1059	1600	1760	1208	733	4.36	5200
<b>350 MWB High Roof Double Cab-in-Van</b>										
2.4 TDCi 100 PS 5-speed**	RWD	3500	2124	1376	1750	2250	1224	900	4.78/5.11	5500/6000
2.4 TDCi 100 PS 6-speed**	RWD	3500	2138	1362	1750	2250	1236	902	3.73/4.27	5500/6000
2.4 TDCi 115 PS	RWD	3500	2138	1362	1750	2250	1236	902	3.73/4.27	5500/6000
2.4 TDCi 140 PS	RWD	3500	2158	1342	1750	2250	1239	919	3.73/4.27	6000/6300
2.4 TDCi 140 PS	<b>AWD</b>	3500	2238	1262	1750	2250	1310	928	4.27	6300

**MWB** = Medium wheelbase. **FWD** = Front-wheel Drive. **RWD** = Rear-wheel Drive. <sup>o</sup>**Gross Payload** = Gross vehicle mass, less kerb mass. **GVM** = Gross vehicle mass. The total permissible all-up weight of a rigid vehicle – i.e. with body, payload, ancillaries, fuel, oil, water, driver and crew. **\*Kerb mass** = The weight of the complete vehicle and all equipment including fuel and water, but without payload, driver or any crew. All kerb masses quoted in this brochure are subject to manufacturing tolerances and are for vehicles with minimum equipment. **GTM** = Gross train mass. The total permissible all-up weight of a rigid vehicle (see GVM) together with its trailer and load. <sup>oo</sup>The illustrated rear axle ratio shown is one example of what is available dependent upon model, payload and engine combination. Alternative ratios are available, in most cases, for more specialised applications. Different GTMs available with alternative rear axle ratios. Please consult your Ford Dealer for details. **Note:** All figures for 350 RWD models are for the vehicle fitted with the standard 1750 kg front axle, specification of the optional 1850 kg front axle will affect these figures. Please consult your Ford Dealer for details. \*\*6-speed transmission replaces 5-speed from autumn 2010.

### Ford Transit Van LWB Medium Roof

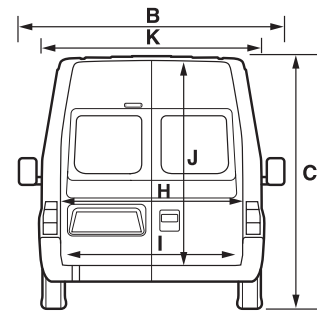
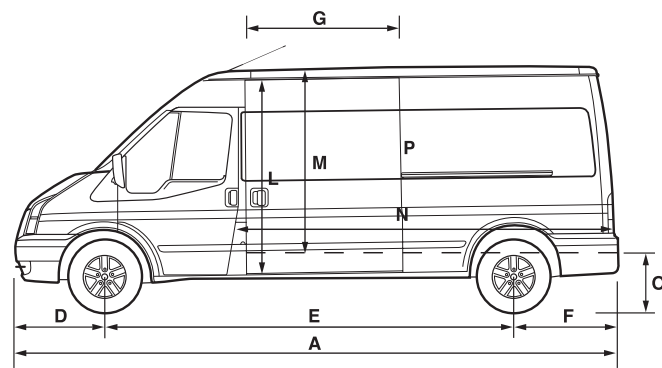

### Ford Transit Van LWB High Roof

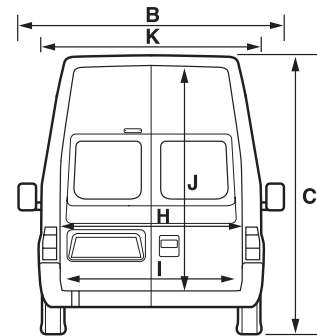
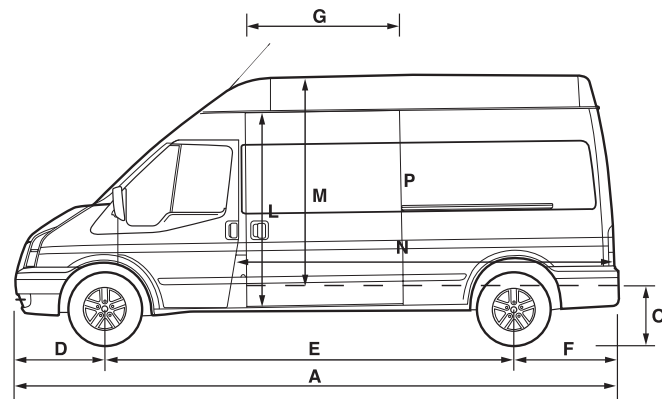

### Ford Transit Double Cab-in-Van LWB Medium Roof

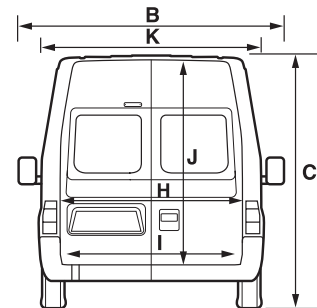
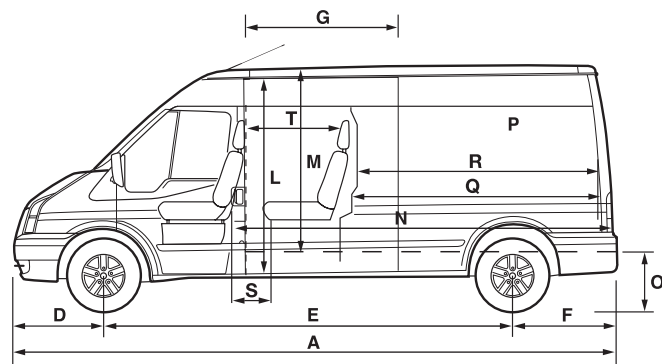

### Ford Transit Double Cab-in-Van LWB High Roof

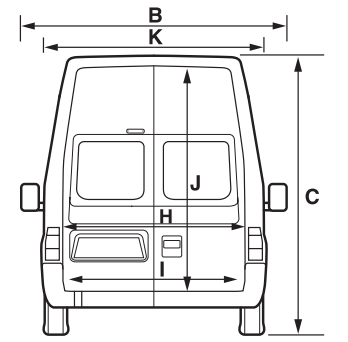
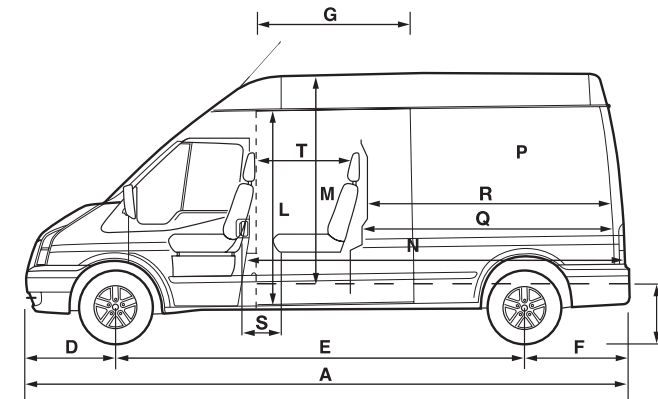

### Dimensions (mm)

	LWB Medium Roof Van		LWB High Roof Van	
	Front-Wheel Drive	Rear-Wheel Drive	Front-Wheel Drive	Rear-Wheel Drive
<b>A</b> Overall length (excluding step where fitted)/length 3.2L 200PS	5680	5680/5751	5680	5680/5751
<b>B</b> Overall width (with/without mirrors)	2374/1974	2374/1974	2374/1974	2374/1974
<b>C</b> Overall height	2326-2381	2384-2403	2543-2599	2602-2619
<b>D</b> Front of vehicle to front wheel centre/length 3.2L 200PS	933	933/1004	933	933/1004
<b>E</b> Wheelbase	3750	3750	3750	3750
<b>F</b> Rear of vehicle to rear wheel centre	997	997	997	997
<b>G</b> Side door entry width	1250	1250	1250	1250
<b>H</b> Rear door entry width	1540	1540	1540	1540
<b>I</b> Loadspace between wheel arches	1390	1390	1390	1390
<b>J</b> Rear door entry height	1666	1566	1896	1796
<b>K</b> Maximum loadspace width	1762	1762	1762	1762
<b>L</b> Side load door entry height	1600	1500	1600	1500
<b>M</b> Load floor to roof	1745	1645	1985	1885
<b>N</b> Maximum loadspace length	3399	3399	3399	3399
<b>O</b> Loading height	538-593	697-711	538-593	705-713
<b>P</b> Loadspace	10.45/8.97 (cu.m)	9.85/8.45 (cu.m)	11.89/10.20 (cu.m)	11.29/9.69 (cu.m)
<b>Double Cab-in-Van unique measurements</b>				
<b>P</b> Loadspace (SAE only)	7.45 (cu.m)	7.10 (cu.m)	8.50 (cu.m)	8.10 (cu.m)
<b>Q</b> Maximum loadspace length	2349	2506	2349	2506
<b>R</b> Minimum loadspace length	2190	2190	2190	2190
<b>S</b> Second row seating – leg clearance	240	240	240	240
<b>T</b> Second row seating – head restraint to head restraint	700	700	700	700
<b>Turning circle (m)</b>				
Kerb to kerb	13.3	13.3	13.3	13.3
Wall to wall	14.3	14.3	14.3	14.3

**Key:** All dimensions (shown in mm) are subject to manufacturing tolerances and refer to minimum specification models and do not include additional equipment. \*Height dimensions show the range from minimum to maximum of a fully laden, lowest payload vehicle to unladen highest payload vehicle. These illustrations are for guidance only. Loadspace shown as SAE/VDA and measured in cubic metres. **VDA method** This is the method used by the Verbund die Automobil Industrie (VDA) in Germany. A VDA figure is determined by filling the loadspace with 'litre' blocks, each measuring 200x100x50 mm. The blocks are then counted, and the numerical result is converted into cubic metres. **SAE method** The SAE (Society of Automotive Engineers) method simply measures the volume of a fine-grained material such as sand or rice which can be deposited into the loadspace. **Ford** favours the use of the more realistic VDA method of calculation for measuring 'useable' interior loadspace.

## Weights and loads

	Driveline	Gross vehicle mass (kg)	Kerb mass (kg)*	Gross payload (kg) <sup>o</sup>	Front axle plated mass (kg)	Rear axle plated mass (kg)	Front axle kerb mass (kg)	Rear axle kerb mass (kg)	Axle ratio <sup>oo</sup>	Max. GTM (kg) with quoted axle ratio
<b>300 LWB Medium Roof Van</b>										
2.2 TDCi 85 PS	FWD	3000	1868	1132	1600	1760	1180	688	4.23	4500
2.2 TDCi 115 PS	FWD	3000	1876	1124	1600	1760	1190	686	4.36	5200
2.2 TDCi 140 PS	FWD	3000	1879	1121	1600	1760	1192	687	4.36	5200
2.4 TDCi 100 PS 5-speed**	RWD	3000	2018	982	1600	1850	1218	800	4.78/5.11	5000/5500
2.4 TDCi 100 PS 6-speed**	RWD	3000	2032	968	1600	1850	1230	802	3.73/4.27	5000/5500
2.4 TDCi 115 PS	RWD	3000	2032	968	1600	1850	1230	802	3.73/4.27	5500/5800
<b>330 LWB Medium Roof Van</b>										
2.2 TDCi 115 PS	FWD	3300	1914	1386	1700	2150	1203	711	4.93	5500
2.4 TDCi 100 PS 5-speed**	RWD	3300	2020	1280	1700	2150	1220	800	4.78/5.11	5500/6000
2.4 TDCi 100 PS 6-speed**	RWD	3300	2034	1266	1700	2150	1232	802	3.73/4.27	5500/6000
2.4 TDCi 115 PS	RWD	3300	2034	1266	1700	2150	1232	802	3.73/4.27	5500/6000
2.4 TDCi 140 PS	RWD	3300	2054	1246	1700	2150	1235	819	3.73/4.27	6000/6100
<b>350 LWB Medium Roof Van</b>										
2.2 TDCi 115 PS	FWD	3500	1914	1586	1750	2250	1203	711	4.93	5500
2.2 TDCi 140 PS	FWD	3500	1917	1583	1750	2250	1205	712	4.93	5500
2.4 TDCi 100 PS 5-speed**	RWD	3500	2020	1480	1750	2250	1220	800	4.78/5.11	5500/6000
2.4 TDCi 100 PS 6-speed**	RWD	3500	2034	1466	1750	2250	1232	802	3.73/4.27	5500/6000
2.4 TDCi 115 PS	RWD	3500	2034	1466	1750	2250	1232	802	3.73/4.27	5500/6000
2.4 TDCi 140 PS	RWD	3500	2054	1446	1750	2250	1235	819	3.73/4.27	6000/6300
2.4 TDCi 140 PS	<b>AWD</b>	3500	2134	1366	1750	2250	1306	828	4.27	6300
3.2 TDCi 200 PS	RWD	3500	2130	1370	1750	2250	1305	825	3.58/4.10	6000/6300
2.3 P 145 PS	RWD	3500	1968	1532	1750	2250	1164	804	5.11/5.44	4500/5000
<b>350 LWB Medium Roof Double Cab-in-Van</b>										
2.4 TDCi 100 PS 5-speed**	RWD	3500	2128	1372	1750	2250	1267	861	4.78/5.11	5500/6000
2.4 TDCi 100 PS 6-speed**	RWD	3500	2143	1357	1750	2250	1279	864	3.73/4.27	5500/6000
2.4 TDCi 115 PS	RWD	3500	2143	1357	1750	2250	1279	864	3.73/4.27	5500/6000
2.4 TDCi 140 PS	RWD	3500	2162	1338	1750	2250	1282	880	3.73/4.27	6000/6300
2.4 TDCi 140 PS	<b>AWD</b>	3500	2243	1257	1750	2250	1352	891	4.27	6300

## Weights and loads

	Driveline	Gross vehicle mass (kg)	Kerb mass (kg)*	Gross payload (kg) <sup>o</sup>	Front axle plated mass (kg)	Rear axle plated mass (kg)	Front axle kerb mass (kg)	Rear axle kerb mass (kg)	Axle ratio <sup>oo</sup>	Max. GTM (kg) with quoted axle ratio
<b>300 LWB High Roof Van</b>										
2.2 TDCi 85 PS	FWD	3000	1895	1105	1600	1760	1187	708	4.23	4500
2.2 TDCi 115 PS	FWD	3000	1903	1097	1600	1760	1197	706	4.36	5200
2.2 TDCi 140 PS	FWD	3000	1906	1094	1600	1760	1199	707	4.36	5200
2.4 TDCi 100 PS 5-speed**	RWD	3000	2045	955	1600	1850	1225	820	4.78/5.11	5000/5500
2.4 TDCi 100 PS 6-speed**	RWD	3000	2060	940	1600	1850	1237	823	3.73/4.27	5000/5500
2.4 TDCi 115 PS	RWD	3000	2060	940	1600	1850	1237	823	3.73/4.27	5500/5800
<b>330 LWB High Roof Van</b>										
2.2 TDCi 115 PS	FWD	3300	1941	1369	1700	2150	1210	731	4.93	5500
2.4 TDCi 100 PS 5-speed**	RWD	3300	2047	1253	1700	2150	1227	820	4.78/5.11	5500/6000
2.4 TDCi 100 PS 6-speed**	RWD	3300	2062	1238	1700	2150	1239	823	3.73/4.27	5500/6000
2.4 TDCi 115 PS	RWD	3300	2062	1238	1700	2150	1239	823	3.73/4.27	5500/6000
2.4 TDCi 140 PS	RWD	3300	2081	1219	1700	2150	1242	839	3.73/4.27	6000/6100
<b>350 LWB High Roof Van</b>										
2.2 TDCi 115 PS	FWD	3500	1941	1559	1750	2250	1210	731	4.93	5500
2.2 TDCi 140 PS	FWD	3500	1944	1556	1750	2250	1212	732	4.93	5500
2.4 TDCi 100 PS 5-speed**	RWD	3500	2047	1453	1750	2250	1227	820	4.78/5.11	5500/6000
2.4 TDCi 100 PS 6-speed**	RWD	3500	2062	1438	1750	2250	1239	823	3.73/4.27	5500/6000
2.4 TDCi 115 PS	RWD	3500	2062	1438	1750	2250	1239	823	3.73/4.27	5500/6000
2.4 TDCi 140 PS	RWD	3500	2081	1419	1750	2250	1242	839	3.73/4.27	6000/6300
2.4 TDCi 140 PS	<b>AWD</b>	3500	2161	1339	1750	2250	1313	848	4.27	6300
3.2 TDCi 200 PS	RWD	3500	2158	1342	1750	2250	1312	846	3.58/4.10	6000/6300
2.3 P 145 PS	RWD	3500	1996	1504	1750	2250	1171	825	5.11/5.44	4500/5000
<b>350 LWB High Roof Double Cab-in-Van</b>										
2.4 TDCi 100 PS 5-speed**	RWD	3500	2156	1344	1750	2250	1273	883	4.78/5.11	5500/6000
2.4 TDCi 100 PS 6-speed**	RWD	3500	2170	1330	1750	2250	1286	884	3.73/4.27	5500/6000
2.4 TDCi 115 PS	RWD	3500	2170	1330	1750	2250	1286	884	3.73/4.27	5500/6000
2.4 TDCi 140 PS	RWD	3500	2190	1310	1750	2250	1288	902	3.73/4.27	6000/6300
2.4 TDCi 140 PS	<b>AWD</b>	3500	2270	1230	1750	2250	1359	911	4.27	6300

**LWB** = Long wheelbase. **FWD** = Front-wheel Drive. **RWD** = Rear-wheel Drive. <sup>o</sup>**Gross Payload** = Gross vehicle mass, less kerb mass. **GVM** = Gross vehicle mass. The total permissible all-up weight of a rigid vehicle – i.e. with body, payload, ancillaries, fuel, oil, water, driver and crew. **\*Kerb mass** = The weight of the complete vehicle and all equipment including fuel and water, but without payload, driver or any crew. All kerb masses quoted in this brochure are subject to manufacturing tolerances and are for vehicles with minimum equipment. **GTM** = Gross train mass. The total permissible all-up weight of a rigid vehicle (see GVM) together with its trailer and load. <sup>oo</sup>The illustrated rear axle ratio shown is one example of what is available dependent upon model, payload and engine combination. Alternative ratios are available, in most cases, for more specialised applications. Different GTMs available with alternative rear axle ratios. Please consult your Ford Dealer for details. **Note:** All figures for 350 RWD models are for the vehicle fitted with the standard 1750 kg front axle, specification of the optional 1850 kg front axle will affect these figures. Please consult your Ford Dealer for details. \*\*6-speed transmission replaces 5-speed from autumn 2010.

## Ford Transit Van EL 'Jumbo' High Roof

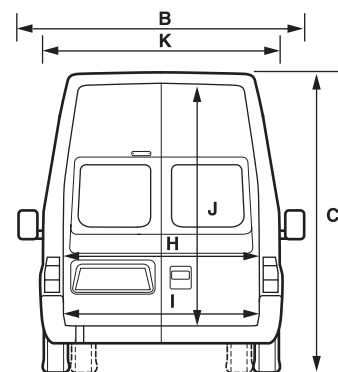
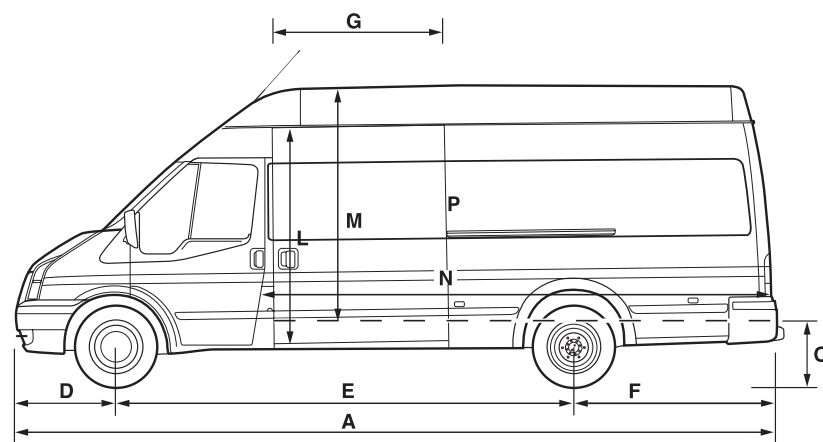

## Ford Transit Double Cab-in-Van EL 'Jumbo' High Roof

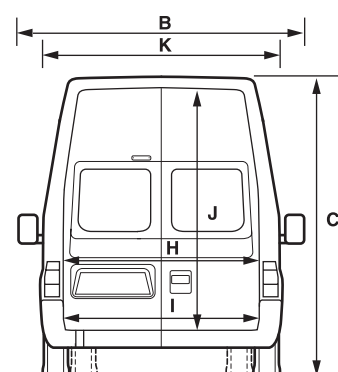
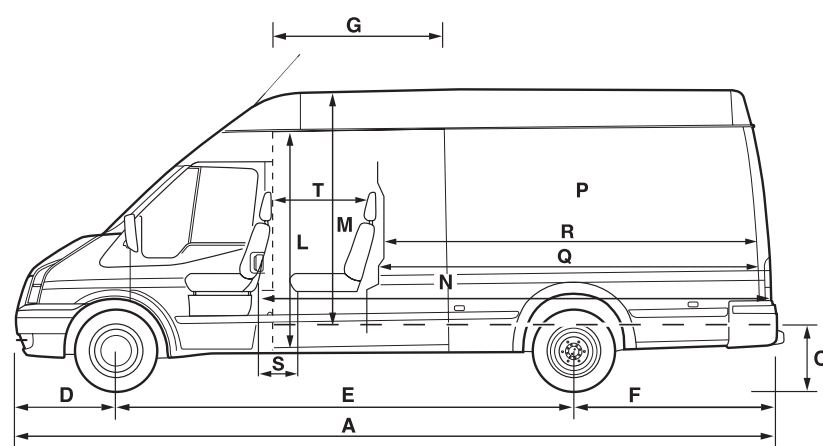

### Dimensions (mm)

	EL 'Jumbo' High Roof Van Rear-Wheel Drive
<b>A</b>	Overall length (excluding step where fitted)/length 3.2L 200PS 6403/6474
<b>B</b>	Overall width (with/without mirrors) 2374/1974 (SRW) 2492/2084 (DRW)
<b>C</b>	Overall height 2608-2629
<b>D</b>	Front of vehicle to front wheel centre/length 3.2L 200PS 933/1004
<b>E</b>	Wheelbase 3750
<b>F</b>	Rear of vehicle to rear wheel centre 1720
<b>G</b>	Side door entry width 1250
<b>H</b>	Rear door entry width 1540
<b>I</b>	Loadspace between wheel arches 1390 (SRW) 1140-1153 (DRW)
<b>J</b>	Rear door entry height 1796

### Dimensions (mm)

	EL 'Jumbo' High Roof Van Rear-Wheel Drive
<b>K</b>	Maximum loadspace width 1762
<b>L</b>	Side load door entry height 1500
<b>M</b>	Load floor to roof 1885
<b>N</b>	Maximum loadspace length 4107
<b>O</b>	Loading height 696-712
<b>P</b>	Loadspace 14.30/12.28 (cu.m)
<b>Double Cab-in-Van unique measurements</b>	
<b>P</b>	Loadspace (SAE only) 10.8 (cu.m)
<b>Q</b>	Maximum loadspace length 3229
<b>R</b>	Minimum loadspace length 2910
<b>S</b>	Second row seating – leg clearance 370
<b>T</b>	Second row seating – head restraint to head restraint 830
<b>Turning circle (m)</b>	
Kerb to kerb	13.3
Wall to wall	14.3

**Key:** All dimensions (shown in mm) are subject to manufacturing tolerances and refer to minimum specification models and do not include additional equipment. \*Height dimensions show the range from minimum to maximum of a fully laden, lowest payload vehicle to unladen highest payload vehicle. These illustrations are for guidance only. Loadspace shown as SAE/VDA and measured in cubic metres. **VDA method** This is the method used by the Verbund die Automobil Industrie (VDA) in Germany. A VDA figure is determined by filling the loadspace with 'litre' blocks, each measuring 200x100x50 mm. The blocks are then counted, and the numerical result is converted into cubic metres. **SAE method** The SAE (Society of Automotive Engineers) method simply measures the volume of a fine-grained material such as sand or rice which can be deposited into the loadspace. **Ford** favours the use of the more realistic VDA method of calculation for measuring 'useable' interior loadspace.

### Weights and loads

	Driveline	Gross vehicle mass (kg)	Kerb mass (kg)*	Gross payload (kg) <sup>o</sup>	Front axle plated mass (kg)	Rear axle plated mass (kg)	Front axle kerb mass (kg)	Rear axle kerb mass (kg)	Axle ratio <sup>oo</sup>	Max. GTM (kg) with quoted axle ratio
<b>350 EL (SRW) 'Jumbo' High Roof Van</b>										
2.4 TDCi 100 PS 5-speed**	RWD	3500	2182	1318	1750	2300	1178	1004	4.78/5.11	5500/6000
2.4 TDCi 100 PS 6-speed**	RWD	3500	2196	1304	1750	2300	1191	1005	3.73/4.27	5500/6000
2.4 TDCi 115 PS	RWD	3500	2196	1304	1750	2300	1191	1005	3.73/4.27	5500/6000
2.4 TDCi 140 PS	RWD	3500	2216	1284	1750	2300	1194	1022	3.73/4.27	6000/6300
3.2 TDCi 200 PS	RWD	3500	2292	1208	1750	2300	1263	1029	3.58/4.10	6000/6300
<b>350 EL HD (Heavy Duty) (DRW) 'Jumbo' High Roof Van</b>										
2.4 TDCi 115 PS	RWD	3500	2275	1225	1850	2600	1205	1070	4.27	6000
2.4 TDCi 140 PS	RWD	3500	2278	1222	1850	2600	1208	1070	4.27	6500
3.2 TDCi 200 PS	RWD	3500	2354	1146	1850	2600	1278	1076	4.10	6500
<b>460 EL (DRW) 'Jumbo' High Roof Van</b>										
2.4 TDCi 115 PS	RWD	4600	2335	2265	1850	3300	1229	1106	4.27	6000
2.4 TDCi 140 PS	RWD	4600	2338	2262	1850	3300	1232	1106	4.27	6500
3.2 TDCi 200 PS	RWD	4600	2416	2184	1850	3300	1303	1113	4.10	6500
<b>350 EL (SRW) 'Jumbo' High Roof Double Cab-in-Van</b>										
2.4 TDCi 100 PS 5-speed**	RWD	3500	2290	1210	1750	2300	1226	1064	4.78/5.11	5500/6000
2.4 TDCi 100 PS 6-speed**	RWD	3500	2305	1195	1750	2300	1238	1067	3.73/4.27	5500/6000
2.4 TDCi 140 PS	RWD	3500	2324	1176	1750	2300	1241	1083	3.73/4.27	6000/6300
3.2 TDCi 200 PS	RWD	3500	2401	1099	1750	2300	1311	1090	3.58/4.10	6000/6300

**LWB EL** = Long wheelbase, extended length. **FWD** = Front-wheel Drive. **RWD** = Rear-wheel Drive. **Gross Payload** = Gross vehicle mass, less kerb mass. **GVM** = Gross vehicle mass. The total permissible all-up weight of a rigid vehicle – i.e. with body, payload, ancillaries, fuel, oil, water, driver and crew. **Kerb mass** = The weight of the complete vehicle and all equipment including fuel and water, but without payload, driver or any crew. All kerb masses quoted in this brochure are subject to manufacturing tolerances and are for vehicles with minimum equipment. **GTM** = Gross train mass. The total permissible all-up weight of a rigid vehicle (see GVM) together with its trailer and load. <sup>oo</sup>The illustrated rear axle ratio shown is one example of what is available dependent upon model, payload and engine combination. Alternative ratios are available, in most cases, for more specialised applications. Different GTMs available with alternative rear axle ratios. Please consult your Ford Dealer for details. **Note:** All figures for 350 RWD SRW models are for the vehicle fitted with the standard 1750 kg front axle, specification of the optional 1850 kg front axle will affect these figures. Please consult your Ford Dealer for details. \*\*6-speed transmission replaces 5-speed from autumn 2010.

## Model availability

	SWB				MWB*			LWB			LWB EL			
	260	280	300	330	280	300	330	350	300	330	350	350	350HD	460
<b>Transit Van</b>														
2.2 Duratorq TDCi Diesel 85 PS	B T	B T	B		B T	B			B					
2.2 Duratorq TDCi Diesel 115 PS	B T L	B T L E	B	B	B T L	B	B	B T	B	B	B T			
2.2 Duratorq TDCi Diesel 140 PS	B T L S	B T L	B	B	B T L	B	B	B T	B		B T			
2.4 Duratorq TDCi Diesel 100 PS				B			B	B T	B	B	B T	B		
2.4 Duratorq TDCi Diesel 115 PS				B			B	B T	B	B	B T	B T	B	B
2.4 Duratorq TDCi Diesel 140 PS				B			B	B T L	B	B T L	B T	B	B	
2.4 Duratorq TDCi Diesel 140 PS (AWD)			B	B				B T L		B T L				
3.2 Duratorq TDCi Diesel 200PS							B			B	B	B	B	
2.3 Duratec Petrol 145 PS				B		B				B				

B = Base, T = Trend, L = Limited, S = SportVan, E = ECONetic. \*MWB with low roof – available on FWD versions only.

	SWB		MWB		LWB		LWB EL	
	260	280	280	300	350	350	350	350
<b>Transit Double Cab-in-Van</b>								
2.2 Duratorq TDCi Diesel 85 PS			B	B				
2.2 Duratorq TDCi Diesel 115 PS	B T	B T	B T	B T				
2.2 Duratorq TDCi Diesel 140 PS			B T L					
2.4 Duratorq TDCi Diesel 100 PS					B	B		
2.4 Duratorq TDCi Diesel 115 PS					B	B		
2.4 Duratorq TDCi Diesel 140 PS					B	B	B	
2.4 Duratorq TDCi Diesel 140 PS (AWD)					B	B		

B = Base, T = Trend, L = Limited.

## Engine data

	Engine technical features	Maximum power <sup>o</sup>	Maximum torque <sup>o</sup>	Transmission
<b>2.2 Duratorq TDCi Diesel 63 kW (85 PS)</b> 2198 cc	4 cylinders in line; DOHC; 16 valves; alloy cylinder head; direct injection with high-pressure, common-rail, multipoint fuel injection system; turbocharger with intercooler; dual-mass flywheel; electronic EGR	63 kW (85 PS) at 3500 min <sup>-1</sup> (rpm)	250 Nm at 1500-2200 min <sup>-1</sup> (rpm)	5-speed transaxle
<b>2.2 Duratorq TDCi Diesel 85 kW (115 PS)</b> 2198 cc	4 cylinders in line; DOHC; 16 valves; alloy cylinder head; direct injection with high-pressure, common-rail, multipoint fuel injection system; VNT turbocharger with intercooler; dual-mass flywheel; electronic EGR	85 kW (115 PS) at 3500 min <sup>-1</sup> (rpm)	300 Nm at 1800-2300 min <sup>-1</sup> (rpm)	6-speed transaxle
<b>2.2 Duratorq TDCi Diesel 103 kW (140 PS)</b> 2198 cc	4 cylinders in line; DOHC; 16 valves; alloy cylinder head; direct injection with high-pressure, common-rail, multipoint fuel injection system; VNT turbocharger with intercooler; dual-mass flywheel; electronic EGR	103 kW (140 PS) at 3500 min <sup>-1</sup> (rpm)	350 Nm at 1800-2400 min <sup>-1</sup> (rpm)	6-speed transaxle
<b>2.4 Duratorq TDCi Diesel 74 kW (100 PS)*</b> 2402 cc	4 cylinders in line; DOHC; 16 valves; alloy cylinder head; direct injection with high-pressure, common-rail, multipoint fuel injection system; turbocharger with intercooler; dual-mass flywheel; electronic EGR	74 kW (100 PS) at 3500 min <sup>-1</sup> (rpm)	285 Nm at 1600-2200 min <sup>-1</sup> (rpm)	6-speed*/5-speed
<b>2.4 Duratorq TDCi Diesel 85 kW (115 PS)</b> 2402 cc	4 cylinders in line; DOHC; 16 valves; alloy cylinder head; direct injection with high-pressure, common-rail, multipoint fuel injection system; turbocharger with intercooler; dual-mass flywheel; electronic EGR	85 kW (115 PS) at 3500 min <sup>-1</sup> (rpm)	310 Nm at 1750-2000 min <sup>-1</sup> (rpm)	6-speed
<b>2.4 Duratorq TDCi Diesel 103 kW (140 PS)</b> 2402 cc	4 cylinders in line; DOHC; 16 valves; alloy cylinder head; direct injection with high-pressure, common-rail, multipoint fuel injection system; VNT turbocharger with intercooler; dual-mass flywheel; electronic EGR	103 kW (140 PS) at 3500 min <sup>-1</sup> (rpm)	375 Nm at 2000 min <sup>-1</sup> (rpm)	6-speed
<b>3.2 Duratorq TDCi Diesel 147 kW (200 PS)</b> 3199 cc	5 cylinders in line; DOHC; 20 valves; alloy cylinder head; direct injection with high-pressure, common-rail, multipoint fuel injection system; VNT turbocharger with intercooler; dual-mass flywheel; electronic EGR	147 kW (200 PS) at 3500 min <sup>-1</sup> (rpm)	470 Nm at 1700-2500 min <sup>-1</sup> (rpm)	6-speed
<b>2.3 Duratec Petrol 107 kW (145 PS)</b> 2261 cc	4 cylinders in line; DOHC; 16 valves; electronic multipoint fuel injection; single-mass flywheel	107 kW (145 PS) at 5250 min <sup>-1</sup> (rpm)	210 Nm at 3850 min <sup>-1</sup> (rpm)	5-speed

<sup>o</sup>Tested in accordance with ISO 1585. **Please note:** All Transit engines are Stage IV emissions level. \*6-speed transmission replaces 5-speed from autumn 2010 (100PS only).

## Mechanical features

	Transit	Trend	Limited	Sport	ECONetic
<b>Brakes</b>					
Dual-circuit, with self-adjusting servo-assistance and ABS. Front and rear discs	●	●	●	●	●
<b>Fuel tank</b>					
Standard – 80 litres	●	●	●	●	●
Long range – 103 litres (RWD diesel engines only, not available on SWB models)	○	○	○		
<b>Steering</b>					
Power-assisted steering	●	●	●	●	●
<b>Suspension</b>					
Front, independent MacPherson struts, variable rate coil springs, stabiliser bar and gas-pressurised shock absorbers. Rear, leaf springs and gas-pressurised shock absorbers	●	●	●	●	●
Front – Ant-roll bar	●	●	●	●	●
<b>Engine and transmission</b>					
cDPF (coated Diesel Particulate Filter) *	○	○	○	○	○
Enhanced traction All-Wheel Drive (AWD) - Generation II with smooth engagement and manual override (available on 300S, 330S, 350M, 350L models with 6-speed 2.4L TDCi 140 PS)	○	○	○		
Speed limiter – 56 mph* (90 km/h) (standard on 460 models/not available on petrol models)	○	○	○	○	
Speed limiter – 62 mph (100 km/h) (not available on petrol models)	○	○	○	○	
Speed limiter – 70 mph (112 km/h) (not available on petrol models)	○	○	○	○	●
<b>Front axle</b>					
1850 kg (optional on RWD 350 models only, standard on 350 HD and 460 models)	○	○	○		

● = Standard, ○ = Option, at extra cost. \*Legal requirement on 460 variants. For full legislation please refer to VOSA. ECONetic stage V model includes cDPF as standard.

## Safety and security features

	Transit	Trend	Limited	Sport	ECOnetic
<b>Safety</b>					
Anti-lock brakes – Electronic, 4-wheel (includes rear disc brakes)	●	●	●	●	●
Electronic Stability Programme (ESP)* with Hill Start Assist (HSA) (not available on petrol or AWD models)	●	●	●	●	●
Airbag – Driver's	●	●	●	●	●
Airbag – Outer front passenger's (standard on All-Wheel Drive with deactivation switch)	○	○	○	●	○
Airbag – Side airbags (only available with certain single passenger seat packs)	○	○	○	○	○
Seat belts – 3-point diagonal inertia reel (all seats)	●	●	●	●	●
<b>Security</b>					
Alarm – Perimeter (includes trailer coupling, when fitted)	○	○	●	●	○
Alarm – Cab interior sensing – Insurance approved Thatcham Category 1 alarm – approval number TCL1-131/1205 (includes trailer coupling, when fitted; includes remote locking with 2 key fobs; not available on DCIV/with 2nd row glazed windows/where full bulkhead is deleted)	○	○	○	○	○
Audio – Enhanced 'Keycode' anti-theft coding	●	●	●	●	●
Doors – Unglazed rear	●	●	●	●	●
Fuel cap – Locking	●	●	●	●	●
Immobiliser – Safeguard Passive Anti-Theft System (PATS) (Insurance-approved Category 2 immobiliser)	●	●	●	●	●
Locks – High security lock-in-latch system, shielded with strengthened mountings	●	●	●	●	●
Locks – Power door dead-locks	●	●	●	●	●
Locks – Remote control locking with 1 key fob	●				●
Locks – Remote control locking with 2 key fobs	○	●	●	●	○
Locks – Remote control central locking with configurable unlocking (For the available configurations please see the separate table)**	○	○	○	○	○
Locks – Auto re-locking, doors re-lock after 45 seconds if no door is opened	●	●	●	●	●
Locks – Audio mis-lock feedback, audible signal if a door is ajar when locking activated	●	●	●	●	●
Locks – Auto locking on drive-away, doors automatically lock at 5 mph	●	●	●	●	●
Locks - Configurable unlocking (see also unlocking configurations table)	○				○
Locks – Key-operated bonnet release	●	●	●	●	●
Locks – Slam locking	○				○
Vehicle Identification Number – Visible	●	●	●	●	●

● = Standard, ○ = Option, at extra cost. \*Includes electronic brake-force distribution (EBD), Hydraulic Brake Assist (HBA) and Brake Traction Control System (BTCS). \*\*For details of the configurations available please consult your Ford Dealer. **Please Note:** Configurable locking must be defined at the time of order, it cannot be ordered as a Dealer-fitted option or accessory.

## Exterior features

	Transit	Trend	Limited	Sport	ECOnetic
<b>Exterior appearance and styling</b>					
Body – Low roof (standard on SWB; option on FWD MWB)	●/○	●/○	●/○	●	●
Body – Medium roof (includes header-mounted package tray) (option on SWB; standard on MWB & LWB)	○/●	○/●	○/●		
Body – High roof (includes header-mounted package tray) (option on MWB & LWB; standard on Jumbo)	○/●	○/●	○/●		
Bodyside mouldings – Black (not available on Jumbo)	○	●	●	●	○
Bumpers – Full width, front and rear	●	●	●	●	●
Bumper – Front, body colour grille and front bumper centre piece (includes front fog lights and integrated stainless steel step trim plates; not available with SVO colours)	□	●	●		□
Bumper – Front, silver painted grille and body colour front bumper section (includes front fog lights and integrated stainless steel step trim plates)				●	
Exhaust – Twin pipes*				●	
Front and rear wheel arch extensions*				●	
Front lower bumper spoiler – Body-coloured with bright centre section*				●	
Paint – Metallic	○	●+	●+	●	○
Rear quarter skirts – Body-coloured*				●	
Rear light guards				●	
Side skirts – Body-coloured with bright inserts*				●	
Twin bonnet stripes* (Delete option available)				●	
Tyres – Summer, Michelin brand (FWD and 330, 350 RWD only; not available with dual rear wheels or 260 GVM)	○	○			
Tyres – Mud and snow, Goodyear brand	○	○			
Tyres – All Weather, Goodyear brand 195/70 R15C 104/102 (280, 300 FWD)	○	○			
Tyres – All Weather, Continental brand 215/75 R16 113/111 (330, 350 FWD / RWD; not with dual rear wheels)	○	○			
Wheels – 5½x15" steel wheels with centre hub covers and 195/70R 15C LI 100/98 BSW tyres (260 models only)	●	●			
Wheels – 5½x15" steel wheels with centre hub covers and 195/70R 15C LI 104/102 BSW tyres (FWD 280 and 300 models only)	●	●			
Wheels – 5½x16" steel wheels with centre hub covers and 205/75R 16C BSW tyres (RWD 300 models only)	●	●			
Wheels – 5½x16" steel wheels with centre hub covers and 215/75R 16C BSW 113/111 tyres (330 and 350 models only – except Jumbo)	●	●			●
Wheels – 5½x16" steel wheels with centre hub covers and 215/75R 16C 116/114 tyres (350 Jumbo models only)	●	●			
Wheels – 5x16" steel wheels with dual rear wheels, partial wheel cover on front wheels and 195/75R 16C tyres (standard on 350 HD and 460 LWB EL models)	●	●			
Wheels – 5½x16" 5-spoke alloy wheels with locking wheel nuts and 205/65R 16C BSW low profile tyres (only available FWD 260, 280 & 300 models) <b>Alloy wheel pack 1</b>	○	○			
Wheels – 5½x16" 5-spoke alloy wheels with locking wheel nuts. 185/75R 16C 104/102 tyres for 260, 280 only, other variants follow steel wheel tyre deployment (not available on Dual Rear Wheel models) <b>Alloy wheel pack 2</b>	○	○	●		
Wheels – 18" alloy* with 235/45 tyres (inflator kit i.l.o. spare tyre)				●	
Wheelcovers – Full (not available on 350 HD and 460 LWB EL models)	○	●			●
<b>Exterior functional</b>					
Doors – With drop window and assist handle	●	●	●	●	●
Doors – Passenger's sliding side load door and step	●	●	●	●	●
Doors – Driver's (dual) sliding side load door and step (standard on MWB low roof models)	○	○	○	○	
Doors - Delete passenger's sliding side load door and step (not available on SWB or DCIV)	○	○	○	○	○
Doors – Unglazed hinged rear doors, 180° opening, positive stop at 90° (not available on Jumbo models)	●	●	●	●	●
Doors – Glazed hinged rear doors with heated rear windows	○	○	○	○	○
Doors – Unglazed hinged rear doors, 256° opening (option includes bodyside mouldings on SWB, MWB /option includes magnetic retainers on LWB/standard including magnetic retainers on Jumbo models)	○	○	○		
Doors – Glazed rear tailgate (in lieu of rear doors) (Low Roof models only)**	○	○	○	○	○
Door mirrors – Blind spot eliminator	●	●	●	●	●
Door mirrors – Electrically-operated* (short arm)	○	●	●	●	○
Door mirrors – Silver painted mirror caps				●	
Glass – Tinted – Light tint complete (71% luminous transmittance)	●	●	●	●	●
Glass – Tinted – Light tint windscreen, front side windows; dark tint rear side windows, rear door glass (35%-44% luminous transmittance; DCIV only)	○	○	○		
Heated windscreen – Quickclear	□	●	●	●	□

## Exterior features

	Transit	Trend	Limited	Sport	ECOnetic
Mudflaps – Front and rear	●	●	●	●	●
Parking distance sensor, rear (includes rear step integrated in bumper; not available with optional tow bar or rear centre step)	○	○	○	○	○
Rear step – Integrated in bumper (not available with optional tow bar)	○	○	○	○	○
Rear step – Centre (no cost option on high roof models but must be specified at time of ordering; not available with optional tow bar)	○	○	○	○	○
Tow bar with 13-pin electrics (tachograph may be required) (not available with optional integrated rear bumper step/rear parking distance sensor/350HD models)	○	○	○	○	
Towing eyes – Front and rear	●	●	●	●	●
Windows – Front, electrically-operated	●	●	●	●	●
Side windows – 2nd row, driver's side, fixed – Van/Double Cab-in-Van	○/●	○/●	○/●	○	○
Side windows – 2nd row, passenger's side, fixed – Van/Double Cab-in-Van	○/●	○/●	○/●	○	○
Side windows – 2nd row, driver's side, sliding (not available on SWB models)	○	○	○		
Side windows – 2nd row, passenger's side, sliding (not available on SWB models)	○	○	○		
Wipers – Front, two-speed with electric wash	●	●	●	●	●
Wipers – Rear with auto reverse wipe and electric wash (only available with glazed rear doors or tailgate)	○	○	○	○	○
<b>Exterior lighting</b>					
Halogen headlights, side lights, rear fog lights, reversing lights	●	●	●	●	●
Front fog lights	○	●	●	●	○
Headlight levelling	●	●	●	●	●
High-mounted rear brake light	●	●	●	●	●
Side marker lights (LWB EL models only)	●	●	●		
Headlights – "Home Safe" facility, 30 seconds duration	●	●	●	●	

● = Standard, ○ = Option, at extra cost, □ = Part of an Option Pack, at extra cost, ●+ = No cost option.

\*Supplied by MS Design. Please note that all supplier-branded accessories are provided with a supplier's warranty and are subject to the supplier's warranty terms. Such accessories are, therefore, excluded from the Ford warranty. \*\*SVO A616/A615 available to allow fitment of tailgate to medium roof. \*Power and heated mirror available from mid 2009.

## Audio and communications

	Transit	Trend	Limited	Sport	ECOnetic
<b>Audio and communications</b>					
Stereo radio/single CD player – Model 6000 RDS with auxiliary MP3 connector; 2 speakers; 24 station pre-sets; 2x17 watts power output and remote steering column-mounted controls	●	●	●**		●
Stereo radio/6-disc CD player* – Model 6006 RDS with auxiliary MP3 connector; 2 speakers; 24 station pre-sets; 2x17 watts power output and remote steering column-mounted controls	○	○	●*	●	○
Sony Radio/CD with DAB** – Remote audio controls, MP3 compatible, Bluetooth® hands free phone with voice control system and USB connectivity port			○**	●**	
Satellite Navigation FX system – Full 7 digit postcode capability; 5" TFT colour display; stereo radio/single CD player with auxiliary MP3 capability; 2 speakers; 24 station pre-sets; 2x20 watts power output and remote steering column-mounted controls.	○	○	○	○	○
Bluetooth® module with wireless integration between 'phone and audio system and voice dialling	○	●	●	●	○

● = Standard, ○ = Option, at extra cost.

The Bluetooth® word mark and logos are owned by the Bluetooth SIG, Inc. and any use of such marks by Ford Motor Company is under license. Other trademarks and trade names are those of their respective owners. \*available until autumn 2010. \*\*available from autumn 2010.

## Interior features

	Transit	Trend	Limited	Sport	ECOnetic
<b>Carpet and trim</b>					
Door trim – Front, moulded with pull handles and storage pockets	●	●	●	●	●
Floor covering – Cab, rubber	●	●	●	●	●
Headlining – Cab, moulded	●	●	●	●	●
<b>Interior lighting</b>					
Courtesy lights – Header-mounted, front door-operated	●	●	●	●	●
Load compartment lights	●	●	●	●	●
Interior lighting/battery saver – 30 minutes	●	●	●	●	●
<b>Instruments and controls</b>					
Instruments – Speedometer, tachometer, odometer, trip recorder, fuel gauge, water temperature gauge and digital clock	●	●	●	●	●
Warning lights for oil pressure, direction indicator, high beam, lights on, ignition/alternator, brake failure, loadspace light on, airbag(s) (where fitted)	●	●	●	●	●
Shift indicator light (displays earlier for more economic driving on ECOnetic)	●	●	●	●	●
Illuminated heater controls – 3-speed fan. Four vents with temperature and direction control, two dedicated side window demisters	●	●	●	●	●
Air vents – Bright finish	●	●	●	●	●
Trip computer (functionality includes clock, distance to fuel empty, average fuel consumption, average speed, outside air temperature)	○	●	●	●	●
Water in fuel filter with sensor (diesel models only)	●	●	●	●	●
Battery – Single – 680CCA – 70Ah@20h rate (260, 280, 300 FWD models only)	●	●	●	●	●
Battery – Twin – 590CCA – 60Ah@20h rate (260, 280, 300 FWD models only)	○	○	○	○	
Battery – Twin – 590CCA – 60Ah@20h rate (330, 350 FWD and RWD models only)	●	●	●		○
Cold start (-20°C)	●	●	●	●	●
Cold start (-29°C) (includes twin heavy duty batteries – 680CCA – 70Ah@20h rate) = 730 cold cranking amps per battery (twin batteries are automatically specified at extra cost for 260, 280, 300 FWD models)	○	○	○	○	○
Tachograph – Digital, electronic, 24-hour (mandatory option for 460 models*)	○	○	○	○	○
Cruise control (includes leather steering wheel with silver effect spokes and leather gear knob with aluminium insert; not available with petrol engine)	○	●	●	●	○
<b>Seats</b>					
Seat trim – Tomy fabric	●	●			●
Seat trim – Kado velour			●	●	
Seat trim – Verona leather			○	○	
Seat trim – York weave vinyl	○				
Front seat – <b>Tomy/8-way</b> driver (fore/aft; recline; height; and tilt)/ <b>Dual</b> passenger seat/manual adjustment with fixed armrest and height adjustable head restraints/(administrative use – <b>seat pack 22</b> )	●	●			●
Front seat – <b>Tomy/8-way</b> driver (fore/aft; recline; height; and tilt)/ <b>Single, 4-way</b> passenger seat (fore/aft; and recline)/manual adjustment with fixed armrest and height adjustable head restraints/(administrative use – <b>seat pack 21</b> )	○	○			○
Front seat – <b>Tomy/10-way</b> driver (fore/aft; recline; height; tilt and lumbar) <b>heated/Dual</b> passenger seat/manual adjustment with fixed armrest and height adjustable head restraints/(administrative use – <b>seat pack 23</b> )	○	○			○
Front seat – <b>Tomy/8-way</b> driver(fore/aft; recline; height; and tilt)/ <b>Single, 8-way</b> passenger seat (fore/aft; recline; height; and tilt)/manual adjustment with fixed armrest and height adjustable head restraints/ <b>side airbags</b> (automatically specifies passenger front airbag at extra cost)/(administrative use – <b>seat pack 30</b> )	○	○			○

## Interior features

	Transit	Trend	Limited	Sport	ECOnetic
Front seat – <b>Tomy/10-way</b> driver (fore/aft; recline; height; tilt and lumbar) <b>heated/Single, 10-way</b> passenger seat (fore/aft; recline; height; tilt and lumbar)/manual adjustment with fixed armrest and height adjustable head restraints <b>heated/side airbags</b> (automatically specifies passenger front airbag at extra cost)/(administrative use – <b>seat pack 31</b> )	○	○			○
Front seat – <b>York/8-way</b> driver(fore/aft; recline; height; tilt and lumbar)/ <b>Dual</b> passenger seat/manual adjustment with fixed armrest and height adjustable head restraints/(administrative use – <b>seat pack 27</b> )	○	○			○
Front seat – <b>Kado/10-way</b> driver (fore/aft; recline; height; tilt and lumbar) <b>heated/Dual</b> passenger seat/manual adjustment with fixed armrest and height adjustable head restraints/(administrative use – <b>seat pack 25</b> )			●	●	
Front seat – <b>Kado/10-way</b> driver (fore/aft; recline; height; tilt and lumbar) <b>heated/Single, 10-way</b> passenger seat (fore/aft; recline; height; tilt and lumbar)/manual adjustment with fixed armrest and height adjustable head restraints <b>heated/(administrative use – seat pack 26)</b>			○	○	
Front seat – <b>Kado/10-way</b> driver (fore/aft; recline; height; tilt and lumbar) <b>heated/Single, 10-way</b> passenger seat (fore/aft; recline; height; tilt and lumbar)/manual adjustment with fixed armrest and height adjustable head restraints <b>heated/side airbags</b> (automatically specifies passenger front airbag at extra cost) (administrative use – <b>seat pack 34</b> )			○	○	
Front seat – <b>Verona/10-way</b> driver (fore/aft; recline; height; tilt and lumbar) <b>heated/Dual</b> passenger seat/manual adjustment with fixed armrest and height adjustable head restraints/(administrative use – <b>seat pack 28</b> )			○	○	
Front seat – <b>Verona/10-way</b> driver (fore/aft; recline; height; tilt and lumbar) <b>heated/Single, 10-way</b> passenger seat (fore/aft; recline; height; tilt and lumbar)/manual adjustment with fixed armrest and height adjustable head restraints <b>heated/side airbags</b> (automatically specifies passenger front airbag at extra cost) (administrative use – <b>seat pack 29</b> )			○	○	
Rear seats – 2nd row; 3-passenger bench (Double Cab-in-Van only)	●	●	●		
Seat belts – Height-adjustable mount, driver's and outer front passenger's side	●	●	●	●	●
<b>Comfort and convenience</b>					
Air conditioning – Front, CFC-free	○	○	●	●	○
Bottle holder – Twin, 2 litre bottle capacity, facia-mounted	●	●	●	●	●
Cup holder – Twin, facia-mounted, drop-down	●	●	●	●	●
Glovebox – With lid and A4 file storage capability, moulded hook in lid	●	●	●	●	●
Grab handle – Passenger's side, A-pillar-mounted	○				○
Heater – Recirculation	●	●	●	●	●
Power point socket (located in driver's top stowage bin)	●	●	●	●	●
Rear auxiliary power point socket (260, 280, 300 FWD models supplied with second battery at extra cost)	●	●	●	●	●
Storage – Front door map pockets (passenger door map pocket deleted with single seat packs)	●	●	●	●	●
Storage – Driver's and passenger's side, storage compartments on facia top with lift up lids.	●	●	●	●	●
Storage – Central slot for 1" A4 binder or clipboard storage	●	●	●	●	●
Storage – Passenger's side open storage area (not available with front passenger's airbag)	●	●	●	●	●
Storage – Centre stack-mounted car park/toll ticket holder	●	●	●	●	●
Sunvisors – Two, swivelling	●	●	●	●	●
Tray – Centre facia-mounted, swivelling with two cupholders and a pen groove	●	●	●	●	●
<b>Load compartment</b>					
Bulkhead <sup>1</sup> – Part width (driver) recess – steel – <b>standard on SWB, optional on MWB, LWB, LWB EL**</b>	●/○	●/○	●/○	●	●
Bulkhead <sup>1</sup> – Full width recess – steel – <b>standard on MWB, LWB, LWB EL, optional on SWB**</b>	●/○	●/○	●/○	○	○
Bulkhead <sup>1</sup> – Part width (driver) recess – steel with window**	○	○	○	○	○
Bulkhead <sup>1</sup> – Full width recess – steel with window**	○	○	○	○	○
Bulkhead – Full width moulded – GRP – no window – <b>Double Cab-in-Van</b> only	●	●	●		
Bulkhead – Vertical, Half width mesh**	○	○	○	○	○
Cargo stowage rail, mid-position**	○	○	○	○	○
Load compartment floor covering – Rubber** (not available on DCiV Jumbo)	○	○			
Load compartment rear board trims – standard on Double Cab-in-Van	○	●			○
Load compartment protection kit – MDF rear trim, full-length rubber mat** (not available on DCiV Jumbo)	○	○	●	●	
Tie-down loops <sup>1</sup> – Load compartment	●	●	●	●	●

● = Standard, ○ = Option, at extra cost. \*\*Not available on Double Cab-in-Van models. <sup>1</sup>Compliant with DIN 75410.

\***Tachograph** – Legal requirement on 460 variants. Exemptions may apply. For full legislation please refer to VOSA. When a vehicle is fitted with a trailer towing attachment it is recommended that a tachograph is fitted, since the ability to tow a trailer giving a GTM of over 3500kg without a tachograph could be considered contrary to EU and UK road traffic law. Tachographs are subject to calibration at an approved centre at additional cost. (Please note that a digital tachograph cannot be retrofitted to FWD vehicles – factory order only).

## Option Packs

	Transit	Trend	Limited	Sport	ECOnetic
Visibility Pack – Quickclear heated windscreen and electrically-operated and heated door mirrors	○				○
Premium Visibility Pack – Quickclear heated windscreen; electrically-operated and heated door mirrors; automatic headlights; automatic front wipers with rain sensor; instrument panel dimmer; front fog lights; and stainless steel front bumper step plates	○	●	●	●	○
Appearance Pack – Body colour grille and front bumper centre piece; full wheelcovers* and bodyside mouldings	○				○
Trunker Pack – Cruise control (includes leather-wrapped steering wheel with silver effect spokes and leather gear knob with acrylic insert); and trip computer (not available with petrol engine)	○	●	●	●	
Smoker's Pack – Front ashtray and cigarette lighter	○	○	○	○	○

● = Standard, ○ = Option, at extra cost. \*Wheelcovers not available with dual rear wheels.



## Configurable locking options – Unlocking configurations

	'Unlock' Press Once	Button Press Twice	'Cargo' Press Once	Unlock Press Twice
<b>Configuration 2</b>				
Driver's door		●		
Passenger's door	●	●		
Driver's side load door		●		●
Passenger's side load door		●	●	●
Rear doors/tailgate		●		●
<b>Configuration 3</b>				
Driver's door	●	●		
Passenger's door		●		
Driver's side load door		●		●
Passenger's side load door		●		●
Rear doors/tailgate		●	●	●
<b>Configuration 5</b>				
Driver's door	●	●		●
Passenger's door		●	●	●
Driver's side load door	●	●		●
Passenger's side load door		●	●	●
Rear doors/tailgate		●		●

**Note:** All locking configurations are optional, at extra cost, and the contents of each configuration are as shown above. Configurable locking must be defined at the time of order, it cannot be ordered as a Dealer-fitted option or accessory.

## Special vehicle options

	SVO Code	Transit	Trend	Limited	Sport	ECONetic
<b>Special Vehicle Options</b>						
<b>Van models</b>						
3850kg MWB high centre-of-gravity van (115PS RWD medium roof only) - Elevating platform use	<b>A990</b>	○				
<b>Wheels and tyres</b>						
Omit spare wheel, carrier, jack and tools	<b>A026</b>	○	○	○		○
<b>Body</b>						
Tailgate – unglazed, medium roof (Van, Double Cab-in-Van)	<b>A615</b>	○	○	○		
Tailgate – glazed, medium roof* (Van, Double Cab-in-Van)	<b>A616</b>	○	○	○		
Unglazed tailgate (SWB, MWB Van, Double Cab-in-Van)	<b>A617</b>	○	○	○	○	○
Omit passenger seat	<b>A304</b>	○	○	○		○
<b>Electrical</b>						
Cyclic durable second battery (1 x 60Ah + 1 x 90Ah cyclic) (260, 280, 300 FWD models supplied with second battery at extra cost)	<b>A736</b>	○	○	○	○	○
Cyclic durable second and third battery** (1 x 60Ah + 2 x 90Ah cyclic) (260, 280, 300 FWD models supplied with second battery at extra cost)	<b>A738</b>	○	○	○		
Auxiliary fuse panel	<b>A526</b>	○	○	○	○	○
Single amber beacon – switch and wiring only (includes A526)	<b>A605</b>	○	○	○	○	○
Twin amber beacon – switch and wiring only (includes A526)	<b>A606</b>	○	○	○	○	○
Engine RPM controller (RWD Diesel only)	<b>A003</b>	○	○	○		
Enhanced LED lighting for loadspace		○	○	○	○	○
<b>Paint</b>						
Special paint – solid and metallic <sup>o</sup>		○	○	○		○

○ = Option, at extra cost. \*Includes heated rear window, rear wash wipe and high mounted brake light. \*\*Single passenger seat mandatory, 3rd battery located under passenger seat. <sup>o</sup>SVO paint suffix number must be entered at time of ordering. Models that have standard or optional painted grille will be supplied with standard black grille and bumper.

### Special Vehicle Options (SVO)

While the Ford Commercial Vehicle range already offers an extensive choice of off-the-shelf features and options, the Special Vehicle Options (SVO) programme goes a step further. With special options ranging from smaller items like a secondary heavy-duty battery, to something as complex as a fully lined and refrigerated van, the SVO team is here to help. So whether you want your next vehicle supplied in a special colour to match your company's livery, or need a dedicated conversion for specialist use, SVO has the flexibility and experience to provide a vehicle that's right for you.

For more information, please speak to your local Ford Transit Specialist Dealer.

# Colour and trim

## Transit Van trim and body colour availability

Seat trim	Trim colour	Solid body colours			Metallic body colours						
		Colorado Red	Frozen White	Blazer Blue	Moondust Silver	Panther Black	Sea Grey	Chill	Avalon	Vision	Ink Blue
<b>Transit</b>											
Tomy fabric	Lichen	●	●	●	○	○	○	○	○	○	○
York Weave vinyl	Lichen	○	○	○	○	○	○	○	○	○	○
<b>Trend</b>											
Tomy fabric	Lichen	●	●	●	●+	●+	●+	●+	●+	●+	●+
<b>Limited</b>											
Kado velour	Lichen	●	●	●	●+	●+	●+	●+	●+	●+	●+
Verona leather	Lichen	○	○	○	○	○	○	○	○	○	○
<b>Sport</b>											
Kado velour	Lichen	●*									●**
Verona leather	Lichen	○*									○**

● = Standard, ○ = Option, at extra cost, ●+ = No charge option; Metallic paint is an option at extra cost on Transit (Base) and is a no charge option on Trend, Limited, leather trim is an option at extra cost. \*available from autumn 2010. \*\*available until autumn 2010.



1



2



3



4



5



6



7



9



10



8

- Classic colours**
- 1 Colorado Red
  - 2 Frozen White
  - 3 Blazer Blue
  - 4 Moondust Silver\*
  - 5 Panther Black\*

- Contemporary colours**
- 6 Sea Grey\*
  - 7 Chill\*
  - 8 Avalon\*
  - 9 Ink Blue\* (Sport Van only)
  - 10 Vision\*

\*Metallic paint (available at extra cost)

Ford understands the colour you select may represent your corporate colour choice for years to come. Therefore we recommend you select one of our classic colours or, if you need a unique colour for your fleet, speak to your local dealer about our SVO colours that offer you more than 100 colour options. Contemporary colours reflect the latest trends in vehicle colouring but are subject to deletion.

**Ford Transit**  
York Weave vinyl trim in Lichen (Option)

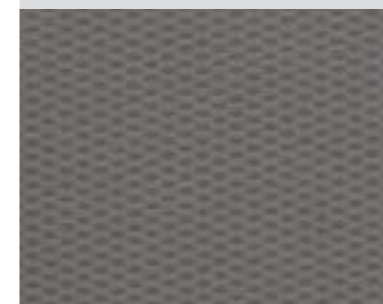

**Ford Transit/Trend**  
Tomy cloth seat trim in Lichen

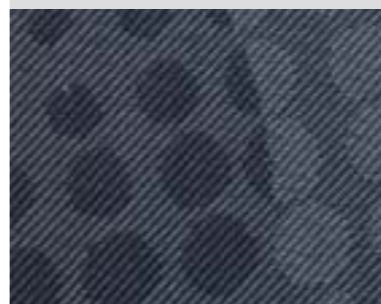

**Ford Transit Limited/SportVan**  
Kado velour seat trim in Lichen



**Ford Transit Limited/SportVan**  
Verona leather seat trim in Lichen (Option)

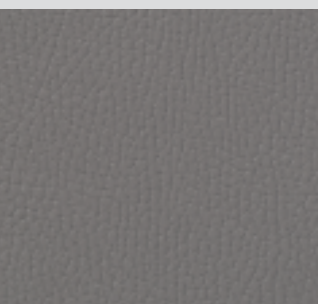

**Note** The images used are to illustrate body colours only and may not reflect the vehicle described. Colours and trims reproduced within this brochure may vary from the actual colours, due to the limitations of the printing processes used.

**Illustrations, descriptions and specifications.** This brochure was correct at the time of going to print. However, Ford policy is one of continuous product development. The right is reserved to change specifications, colours and prices of the models and items illustrated and described in this publication at any time. For the latest details always consult your Ford Dealer. **Optional equipment.** Throughout this publication, wherever a feature is described as being an 'Option' or 'Optional Fitment/Pack', etc., you should assume that it will be at extra cost to the base vehicle, unless specifically stated to the contrary. All models and colour combinations are subject to availability. **Note.** Some images portrayed are of a pre-production model and/or are computer generated, therefore, the design/features on the final version of the vehicle may differ in various respects. In addition, some of the features shown on the vehicles may be optional. **Note.** This brochure contains both original Ford accessories as well as a range of carefully selected products from our suppliers, which are featured under their own brands. All supplier branded products are subject to warranty terms defined by the relevant suppliers and do not lie within the responsibility of Ford. **Note.** The Bluetooth® word mark and logos are owned by the Bluetooth SIG, Inc, and any use of such marks by Ford Motor Company is under licence. Other trademarks and trade names are those of their respective owners.

**The Government fuel figures** do not express or imply any guarantee of the fuel consumption of any particular car. The cars themselves have not been tested and there are inevitably differences between individual cars of the same model. In addition, a car may incorporate particular modifications. Furthermore, the driver's style and road and traffic conditions, as well as the extent to which the car has been driven and the standard of maintenance, will affect its fuel consumption. **Insurance groups** are only as recommended by the Association of British Insurers. You should always consult your insurance adviser for confirmation.



Collect Nectar points at participating Ford Dealers and Authorised Repairers now. So take a look at the latest Ford Service Promotions by visiting the Owner Services section within [www.ford.co.uk](http://www.ford.co.uk).



Ford and BP – working together to reduce fuel consumption and emissions.



BY APPOINTMENT TO  
HER MAJESTY THE QUEEN  
MOTOR VEHICLE MANUFACTURERS  
FORD MOTOR COMPANY LIMITED  
BRENTWOOD ESSEX



BY APPOINTMENT TO  
HER MAJESTY THE PRINCESS OF WALES  
MOTOR VEHICLE MANUFACTURERS  
FORD MOTOR COMPANY LIMITED  
BRENTWOOD ESSEX



When you have finished with this brochure please recycle it.

Published by Commercial Vehicle Marketing,  
Ford Motor Company Limited,  
Brentwood, Essex, England.  
Registered in England No. 235446.  
**FA 1551/3**  
BJN 307004. FoE H47E.  
PN 077501/0610/81.2m/GBR en.  
June 2010.  
© Ford Motor Company Limited.

[www.fordvans.co.uk](http://www.fordvans.co.uk)

