

CTS RANGE



CTS SEDAN



CTS SEDAN

EXTERIOR

UltraView Sunroof:

An optional UltraView sunroof with a power tilt-and-slide panel, express-open and power sunshade brings the open air to driver and passengers alike.

Wheels:

Standard 18" aluminum wheels with a premium multi-coat painted finish come together with P235/50R18 tires, not to mention performance brake and cooling systems. 19" polished aluminum wheels with performance-oriented tires are also available.



Adaptive Forward Lighting:

Turn night into day. High-Intensity Discharge (HID) headlamps with Adaptive Forward Lighting light corners when the sun goes down. The stacked headlamps swivel up to 15° in the direction of travel, thanks to intelligent sensors that read speed and steering angle.



INTRODUCING THE CADILLAC CTS SEDAN.

A star graduate of Germany's notorious Nürburgring racetrack, the CTS Sedan leaves no doubt as to its performance intent. Combining advanced technologies with lavish luxury and expressive design, the CTS Sedan is unmistakably Cadillac.

Sculpted by expert modelers and designers – rather than shaped by a computer – this is a car with spirit, not a soulless science project.

Nor are the performance figures just a meaningless ego massage. There is substance behind the available 322 hp 3.6L Direct Injection V6 power plant – a 157 cm wide track aids control, and options like all-wheel drive (AWD) take that control to a whole new level. The Cadillac CTS Sedan. A dynamic new presence in the staid world of luxury sedans.



CTS SEDAN

INTERIOR

Inside the CTS Sedan, you will find a compelling blend of technical sophistication, precision tailoring and well-appointed character.

The cabin blends modern design and technology with classic craftsmanship. Major aspects of the cabin are cut and sewn by hand. You will feel the luxury in everything you touch and feel, starting with the leather wrapped steering wheel. Master craftsmen expertly cut, sew and wrap the luxurious accents for a finely tailored interior. The Ebony interior features charcoal gray contrast stitching. Luxurious finishing touches include the French-stitched leather seating surfaces, and ambient lighting on every CTS Sport Sedan as well as standard remote start and an optional heated steering wheel.



Infotainment:

A 40 GB infotainment center incorporates a Bose® 5.1 audio system and navigation system as standard. Its LCD screen, which glides up out of the dash, delivers 800 x 480 pixel color resolution and even displays MP3 playlists through USB and auxiliary audio jacks.

Rear-view Camera System & Ultrasonic Park Assist System:

Enjoy increased comfort and vehicle control with the CTS's standard rear-view camera, viewable on the glide up navigation screen. This camera perfectly complements the Ultrasonic Park Assist system, the two together offering greatly improved overall awareness.

Steering Wheel Controls & Electrochromic Rear-view Mirror:

Adjust cruise control and audio functions without taking your hands off the wheel, through ergonomic steering wheel controls. The concept of automation is taken further by a rear-view mirror featuring sensors to automatically dim and eliminate unwanted glare.

CTS SEDAN

ENGINES & TRANSMISSIONS

Racetrack-Honed Chassis:

The CTS Sedan's chassis enables the perfect balance of performance and luxury, and delivers an abundance of grip. The tuning and orchestration of its elements were tested and retested on one of the most challenging stretches of road on the planet – the Nürburgring Nordschleife.

Limited-Slip Differential:

In addition to the Nürburgring-tuned rear-wheel drive (RWD) platform, an AWD model is available featuring an advanced limited-slip differential. The system allows torque to be distributed as needed to individual wheels, ensuring that every last ounce of available grip is exploited.

Hydra-Matic Gearbox:

Both RWD and AWD models feature Hydra-Matic 6-speed automatic transmission. This transmission features Driver Shift Control, inherited from the legendary Cadillac V-Series, delivering a manual feel but with lightning-fast, automatic shifting.

Welcome to the fast lane.

One touch of the accelerator and the extraordinarily powerful 3.6L Direct Injection V6 puts an adrenaline-pumping 237 kW / 322 hp at your command. And the standard CTS Sedan engine – a 3.0L V6 with 203 kW / 276 hp – provides more than enough power, combining punch with controlled acceleration under all conditions.

Both power trains offer Direct Injection technology, as well as employing variable valve timing to optimize power and fuel efficiency, and reduce emissions.



CTS SEDAN

TRIM LEVELS & EQUIPMENT

THE CTS SEDAN INCORPORATES SOME OF THE INDUSTRY'S BEST LUXURY ATTRIBUTES, ADVANCED TECHNOLOGIES AND ELECTRONICS.

HIGHLIGHTS OF STANDARD 'ELEGANCE' MODEL:

- High-performance 3.0L V6 engine (203 kW / 276 hp) with Direct Injection and variable valve timing
- Sport suspension
- Performance brake and cooling system
- 18"x 8" aluminum wheels with premium multi-coat painted finish
- P235/50 R18 V-rated tires
- Hydra-Matic 6-speed automatic transmission with Driver Shift Control performance shifting and Sport Mode
- Rake and telescopic steering column

- Leather interior
- Driver and front passenger seats with 8-way power seat adjuster and additional 2-way power lumbar control
- Memory package, including 2 'presets' for power driver seat, outside mirrors, driver personalization features and power-adjustable pedals
- Air-conditioning with dual-zone automatic climate control and individual climate settings
- Bose® audio system with HDD-based navigation, CD player, 5.1 cabin surround, USB port, and integrated voice control
- Rear-view camera system
- Rear Parking Assist, ultrasonic with audible warning chimes

ADDITIONAL HIGHLIGHTS OF

'SPORT LUXURY' MODEL:

- High-performance 3.6L V6 engine (237 kW / 322 hp) with Direct Injection and variable valve timing
- Rear-wheel drive (RWD) including:
 - Sport performance suspension
 - 19"x 8.5" aluminum wheels with high-polished finish
 - P245/45 R19 Y-rated tires
 - Limited-slip differential
 - Steering-wheel-mounted paddle shift controls

- All-wheel drive (AWD) including:
 - Sport suspension
 - 18"x 8" aluminum wheels with high-polished finish
 - P235/50R18 V-rated tires
- Heated and ventilated front seats
- Power rake steering wheel and telescopic steering column
- Keyless access – passive entry / remote start / ignition

OPTIONAL EQUIPMENT FOR 'ELEGANCE' AND 'SPORT LUXURY' MODELS:

- Wood trim package:
 - Real sapele wood on
 - Instrument panel
 - Center console
 - Door trim
 - Steering wheel and shift knob
- Heated steering wheel when combined with 'Sport Luxury'
- Power UltraView double-sized sunroof with express-open and power sunshade



CTS SEDAN

TECHNICAL INFORMATION

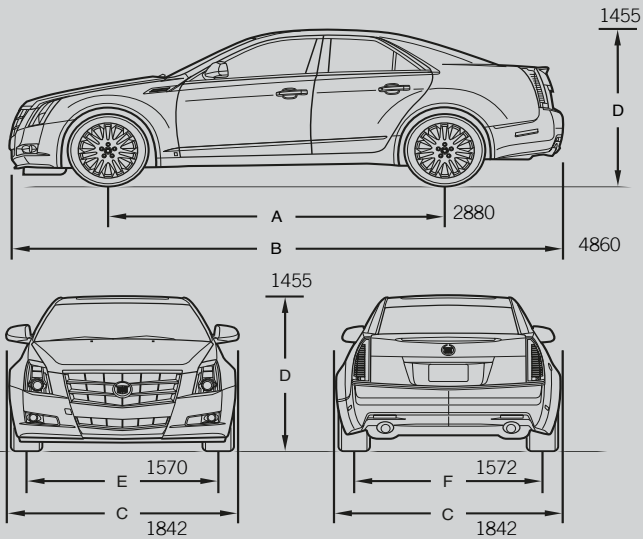

ENGINE:

3.0L V6 'ELEGANCE':

- Variable valve timing and Direct Injection petrol engine
- Maximum power (kW): 203
- Maximum power (hp): 276
- Maximum torque (Nm): 302
- Top speed in km/h: 225
- Acceleration 0–100 km/h (s): 8.0
- Fuel consumption:
 - urban: 16 l / 100 km
 - extra-urban: 7.5 l / 100 km
 - combined: 10.6 l / 100 km
- CO₂ emissions combined: 246 g/km

3.6L V6 'SPORT LUXURY':

- Variable valve timing and Direct Injection petrol engine
- Maximum power (kW): 237
- Maximum power (hp): 322
- Maximum torque (Nm): 372

RWD HYDRA-MATIC 6-SPEED
AUTOMATIC TRANSMISSION:

- Acceleration 0–100 km/h (s): 6.3
- Top speed in km/h: 241
- Fuel consumption:
 - urban: 15.3 l / 100 km
 - extra-urban: 7.3 l / 100 km
 - combined: 10.3 l / 100 km
- CO₂ emissions combined: 241 g/km

AWD HYDRA-MATIC 6-SPEED
AUTOMATIC TRANSMISSION:

- Acceleration 0–100 km/h (s): 6.7
- Top speed in km/h: 225
- Fuel consumption:
 - urban: 15.7 l / 100 km
 - extra-urban: 7.5 l / 100 km
 - combined: 10.5 l / 100 km
- CO₂ emissions combined: 247 g/km

FUEL EFFICIENCY CATEGORY:

3.0L V6 'ELEGANCE':

BE: F
CH: F
DE: F
DK: G
LU: F
NL: G
UK: L

3.6L V6 RWD 'SPORT LUXURY':

BE: F
CH: G
DE: F
DK: G
LU: F
NL: F
UK: L

3.6L V6 AWD 'SPORT LUXURY':

BE: F
CH: G
DE: F

DK: G
LU: F
NL: G
UK: L

WHEELS:

3.0L V6 'ELEGANCE':

- 18"x 8" aluminum wheels with premium multi-coat painted finish
- P235/50 R18 V-rated tires

3.6L V6 'SPORT LUXURY':

RWD models:

- 19"x 8.5" polished aluminum wheels
- P245/45 R19 Y-rated tires

AWD models:

- 18"x 8" polished aluminum wheels
- P235/50 R18 V-rated tires

DIMENSIONS IN MM:

Exterior length: 4860

Height: 1455

Width: 1842

Wheelbase: 2880

Track width front: 1570

Track width rear: 1572

FURTHER DIMENSIONS:

Turning radius (m): 10.96

Trunk volume (l): 373

Fuel tank (l): 68

CTS COUPE



CTS COUPE

EXTERIOR

Auto-Touch Door Releases:

Keyless, touchpad door releases are almost invisible and accentuate the CTS Coupe's clean lines. The personalized fob will unlock the CTS Coupe when you activate the touchpad or push the deck-lid button. The standard remote start system can turn on the engine from as far away as 60 meters.

Adaptive Forward Lighting:

Turn night into day. High-Intensity Discharge (HID) headlamps with Adaptive Forward Lighting light corners when the sun goes down. The stacked headlamps swivel up to 15° in the direction of travel, thanks to intelligent sensors that read speed and steering angle.



Wheels:

Standard 18" aluminum wheels with a premium multi-coat painted finish come together with P235/50R18 tires, not to mention performance brake and cooling systems. 19" polished aluminum wheels with performance-oriented tires are also available.



The CTS Coupe is the ultimate expression of Cadillac's commitment to performance driving and uncompromising design. The latest and most dramatic of Cadillac's new series of designs to reach production, the CTS Coupe is virtually unchanged from the 2008 concept car, but more than delivers in the real world. Tested and tuned on one of the most demanding and challenging stretches of road on the planet – the Nürburgring Nordschleife – the Coupe is a true driver's car. The performance-oriented chassis helps keep the car planted right where you want it, and ensures that the CTS Coupe stands apart in a class of its own – a class that offers a unique mix of American character and European handling. It is a fearsome combination.



CTS COUPE

INTERIOR

The CTS Coupe's cabin blends modern design and technology with classic craftsmanship. Luxurious finishing touches include French-stitched leather seating surfaces, keyless start, push-button door release, ambient lighting and a heated steering wheel. Major aspects of the cabin are cut and sewn by hand. You will feel the luxury in everything you touch and feel, starting with the leather wrapped steering wheel. Master craftsmen expertly cut sew and wrap the luxurious interior accents for a finely tailored interior. The Ebony interior features charcoal gray contrast stitching.



Infotainment:

A 40 GB infotainment center incorporates a Bose® 5.1 audio system and navigation system as standard. Its LCD screen, which glides up out of the dash, delivers 800 x 480 pixel color resolution and even displays MP3 playlists through USB and auxiliary audio jacks.

Rear-view Camera System & Ultrasonic Park Assist System:

Enjoy increased comfort and vehicle control with the CTS's standard rear-view camera, viewable on the glide up navigation screen. This camera perfectly complements the Ultrasonic Park Assist system, the two together offering greatly improved overall awareness.

Steering Wheel Controls & Electrochromic Rear-view Mirror:

Adjust cruise control and audio functions without taking your hands off the wheel, through ergonomic steering wheel controls. The concept of automation is taken further by a rear-view mirror featuring inbuilt sensors to automatically dim and eliminate unwanted glare.



CTS COUPE

ENGINES & TRANSMISSIONS

Racetrack-Honed Chassis:

The CTS Coupe's chassis enables the perfect balance of performance and luxury, and delivers an abundance of grip. The tuning and orchestration of its elements were tested and retested on one of the most challenging stretches of road on the planet – the Nürburgring Nordschleife.



Limited-Slip Differential:

In addition to the Nürburgring-tuned rear-wheel drive (RWD) platform, an all-wheel drive (AWD) model is available featuring an advanced limited-slip differential. The system allows torque to be distributed as needed to individual wheels, ensuring that every last ounce of available grip is exploited.

Hydra-Matic Gearbox:

Both RWD and AWD models feature Hydra-Matic 6-speed automatic transmission. This transmission features Driver Shift Control, inherited from the legendary Cadillac V-Series, and delivers a manual feel but with lightning-fast, automatic shifting.

Welcome to the fast lane. One touch of the accelerator and the extraordinarily powerful 3.6L Direct Injection V6 puts an adrenaline-pumping 322 hp at your command. A wide-stance performance suspension brings sports car verve. Choose from rear-wheel and all-wheel drive. Both mount a Hydra-Matic 6-speed automatic transmission inherited from the legendary Cadillac V-Series. It features Driver Shift Control (DSC) – which lets you select clutchless manual operation. A quick tap of the shifter is then all you need for lightning fast, high-performance shifts. The 3.6L rear-wheel drive model also comes with steering wheel-mounted shift paddles for quick clutchless shifting with the Driver Shift Control.



CTS COUPE

TRIM LEVELS & EQUIPMENT



THE CTS COUPE INCORPORATES SOME OF THE INDUSTRY'S BEST LUXURY ATTRIBUTES, ADVANCED TECHNOLOGIES AND ELECTRONICS.

HIGHLIGHTS OF STANDARD 'SPORT LUXURY' MODEL:

- High-performance 3.6L V6 engine (237 kW / 322 hp) with Direct Injection and variable valve timing
- Performance brake and cooling system
- Hydra-Matic 6-speed automatic transmission with Driver Shift Control performance shifting and Sport Mode
- Rake and telescopic steering column
- Leather interior
- Heated and ventilated front seats
- Driver and front passenger seats with 8-way power seat adjuster and additional 2-way power lumbar control
- Memory package including 2 'presets' for power driver seat, outside mirrors, driver personalization features and power-adjustable pedals

- Air-conditioning with dual-zone automatic climate control and individual climate settings
- Bose® audio system with HDD-based navigation, CD player, 5.1 cabin surround, USB port, and integrated voice control
- Rear-view camera system
- Rear Parking Assist, ultrasonic with audible warning chimes
- Keyless access – passive entry / remote start / ignition
- Rear-wheel drive (RWD) including:
 - Sport performance suspension
 - 19" x 8.5" aluminum wheels with high-polished finish
 - P245/45 R19 Y-rated tires
 - Limited-slip differential
 - Steering-wheel-mounted paddle shift controls
- All-wheel drive (AWD) including:
 - Sport suspension
 - 18" x 8" aluminum wheels with premium multi-coat painted finish
 - P235/50 R18 V-rated tires

- Limited-slip differential
- CTS Coupe RWD is available as manual 6-speed shift version as well

OPTIONAL EQUIPMENT FOR 'SPORT LUXURY' EDITION:

- Wood trim package:
 - Real sapele wood on
 - Instrument panel
 - Center console
 - Door trim
 - Steering wheel and shift knob
- Heated steering wheel
- Power tilt-to-open sunroof with power sunshade

CTS COUPE

TECHNICAL INFORMATION

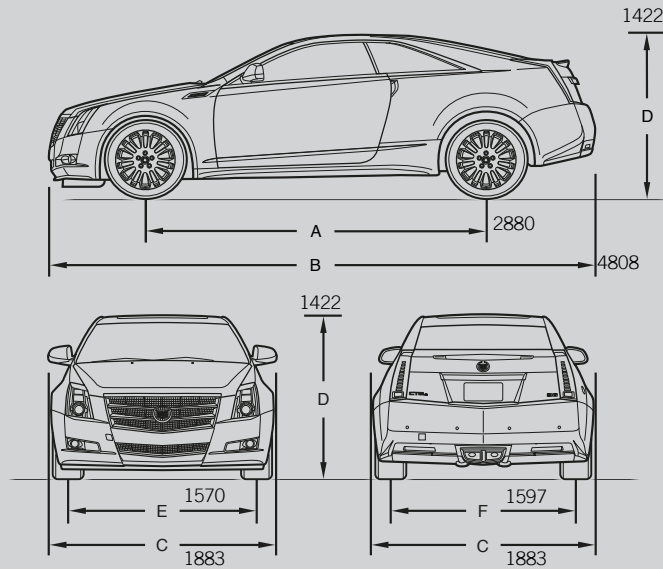

ENGINE:

3.6L V6 ENGINE:

- Variable valve timing and Direct Injection petrol engine
- Maximum power (kW): 237
- Maximum power (hp): 322
- Maximum torque (Nm): 372

RWD HYDRA-MATIC 6-SPEED AUTOMATIC TRANSMISSION:

- Acceleration 0–100 km/h (s): 6.3
- Top speed in km/h: 241
- Fuel consumption:
 - urban: 16.1 l / 100 km
 - extra-urban: 7.9 l / 100 km
 - combined: 10.9 l / 100 km
- CO₂ emissions combined: 255 g/km

AWD HYDRA-MATIC 6-SPEED AUTOMATIC TRANSMISSION:

- Acceleration 0–100 km/h (s): 6.7
- Top speed in km/h: 225
- Fuel consumption:
 - urban: 16.1 l / 100 km
 - extra-urban: 7.9 l / 100 km
 - combined: 10.9 l / 100 km
- CO₂ emissions combined: 255 g/km

FUEL EFFICIENCY CATEGORY:

3.6L V6 RWD 'SPORT LUXURY':

BE: G
CH: G
DE: G
DK: G
LU: G
NL: G
UK: L

3.6L V6 AWD 'SPORT LUXURY':

BE: G
CH: G
DE: G
DK: G
LU: G
NL: G
UK: L

WHEELS:

AWD models:

- 18"x 8" aluminum wheels with premium multi-coat painted finish
- P235/50 R18 V-rated tires

RWD models:

- 19"x 8.5" aluminum wheels with high-polished finish
- P245/45 R19 Y-rated tires

DIMENSIONS IN MM:

Length: 4808
Height: 1422
Width: 1883
Wheelbase: 2880
Track width front: 1570
Track width rear: 1597

FURTHER DIMENSIONS:

Turning radius (m): 10.96
Trunk volume (l): 344
Fuel tank (l): 68

CTS SPORT WAGON



CTS SPORT WAGON

EXTERIOR

Wheels:

Standard 18" aluminum wheels with a premium multi-coat painted finish come together with P235/50R18 tires, not to mention performance brake and cooling systems. 19" polished aluminum wheels with performance-oriented tires are also available.

UltraView Sunroof:

An optional UltraView sunroof with a power tilt-and-slide panel, express-open and power sunshade brings the open air to driver and passengers alike.

Integrated Roof Rails:

Exclusive 'hidden' roof rails with cross bows come standard with every CTS Sport Wagon and help to maintain a seamless exterior and uninterrupted profile, while enhancing cargo options.



Welcome to a new standard in sport wagons – the CTS Sport Wagon. A performance-bred luxury vehicle that yields to no one. Sharing genes with the world-class CTS and CTS-V, the CTS Sport Wagon's performance credentials are beyond question. In practical terms, it delivers just as you might expect – it has cargo space to burn. And this seamless combination of innovative utility and high performance is all set to the intoxicating tone of a powerful V6 engine.

The dynamic appearance of the CTS Sport Wagon shakes up a class traditionally known for conservative design. If you are looking for a sport wagon that will blend in at the local tennis club, you are looking at the wrong brochure.



CTS SPORT WAGON

INTERIOR

The cabin blends modern design and technology with classic craftsmanship. Luxurious finishing touches include French-stitched leather seating surfaces, keyless start, and a heated steering wheel. Major aspects of the cabin are cut and sewn by hand. You will feel the luxury in everything you touch and feel, starting with the leather wrapped steering wheel. Master craftsmen expertly cut, sew and wrap the luxurious accents for a finely tailored interior. The Ebony interior features charcoal gray contrast stitching.

Spacious and comfortable, the CTS Sport Wagon is as practical as it is sporty. A full instrumentation driver information center and navigation screen displays vehicle running data, while ambient lighting uses LED spots and light tubes to bathe the interior in a sophisticated and calming glow.



Power Liftgate:

A power liftgate with memory height position allows rear hatch opening height to be preset. Floor rails are fitted with attachment points for tie-downs.

Cargo Room:

The CTS Sport Wagon has cargo space to burn. Over 700 liters of lined cargo room awaits behind the rear seats. Fold the split rear seats flat and expand that area to nearly 1,500 liters.

Infotainment:

A 40 GB infotainment center incorporates a Bose® 5.1 audio system and navigation system as standard. Its LCD screen, which glides up out of the dash, delivers 800 x 480 pixel color resolution and even displays MP3 playlists through USB and auxiliary audio jacks.

CTS SPORT WAGON

ENGINES & TRANSMISSIONS

Racetrack-Honed Chassis:

The CTS Sport Wagon chassis delivers performance, luxury and an abundance of grip. The tuning and orchestration of its elements were tested and retested on one of the most challenging stretches of road on the planet – the Nürburgring Nordschleife.

Limited-Slip Differential:

In addition to the Nürburgring-tuned rear-wheel drive (RWD) platform, an all-wheel drive (AWD) model is available featuring an advanced limited-slip differential. The system allows torque to be distributed as needed to individual wheels, ensuring that every last ounce of available grip is exploited.

Hydra-Matic Gearbox:

Both RWD and AWD models feature Hydra-Matic 6-speed automatic transmission. This transmission features Driver Shift Control, inherited from the legendary Cadillac V-Series, delivering a manual feel but with lightning-fast, automatic shifting.

There are not many sport wagons that deliver anywhere near 203 kW / 276 hp. And fewer still that can boast 237 kW / 322 hp. Welcome to the CTS Sport Wagon's 3.0L and 3.6L V6 power trains.

A Direct Injection system leads to a great balance of performance and fuel economy – delivering fuel more precisely, it increases the efficiency of combustion, allowing less fuel to be consumed and fewer emissions to be created. The system also acts to reduce cold-start emissions by up to 25 percent. Along with Direct Injection technology, both engines also employ variable valve timing to further optimize power, fuel efficiency and lower emissions.



CTS SPORT WAGON

TRIM LEVELS & EQUIPMENT

THE CTS SPORT WAGON INCORPORATES SOME OF THE INDUSTRY'S BEST LUXURY ATTRIBUTES, ADVANCED TECHNOLOGIES AND ELECTRONICS.

HIGHLIGHTS OF STANDARD 'ELEGANCE' MODEL:

- High-performance 3.0L V6 engine (203 kW / 276 hp) with Direct Injection and variable valve timing
- Sport suspension
- Performance brake and cooling system
- 18"x 8" aluminum wheels with premium multi-coat painted finish
- P235/50 R18 V-rated tires
- Hydra-Matic 6-speed automatic transmission with Driver Shift Control performance shifting and Sport Mode
- Rake and telescopic steering column

- Leather interior
- Heated driver and front passenger seats
- Driver and front passenger seats with 8-way power seat adjuster and additional 2-way power lumbar control
- Memory package including 2 'presets' for power driver seat, outside mirrors, driver personalization features and power-adjustable pedals
- Air-conditioning with dual-zone automatic climate control and individual climate settings
- Bose® audio system with HDD-based navigation, CD player, 5.1 cabin surround, USB port, and integrated voice control
- Rear-view camera system
- Rear Parking Assist, ultrasonic with audible warning chimes

ADDITIONAL HIGHLIGHTS OF 'SPORT LUXURY' MODEL:

- High-performance 3.6L V6 engine (237 kW / 322 hp) with Direct Injection and variable valve timing
- Rear-wheel drive (RWD) including:
 - Sport performance suspension
 - 19"x 8.5" aluminum wheels with high-polished finish
 - P245/45 R19 Y-rated tires
 - Limited-slip differential
 - Steering-wheel-mounted paddle shift controls

- All-wheel drive (AWD) including:
 - Sport suspension
 - 18"x 8" aluminum wheels with high-polished finish
 - P235/50 R18 V-rated tires
 - Limited-slip differential
- Heated and ventilated front seats
- Power rake steering wheel and telescopic steering column
- Keyless access – passive entry / remote start / ignition

OPTIONAL EQUIPMENT FOR 'ELEGANCE' AND 'SPORT LUXURY' MODELS:

- Wood trim package:
 - Real sapele wood on
 - Instrument panel
 - Center console
 - Door trim
 - Steering wheel and shift knob
- Heated steering wheel when combined with 'Sport Luxury'
- Power UltraView double-sized sunroof with express-open and power sunshade



CTS SPORT WAGON

TECHNICAL INFORMATION

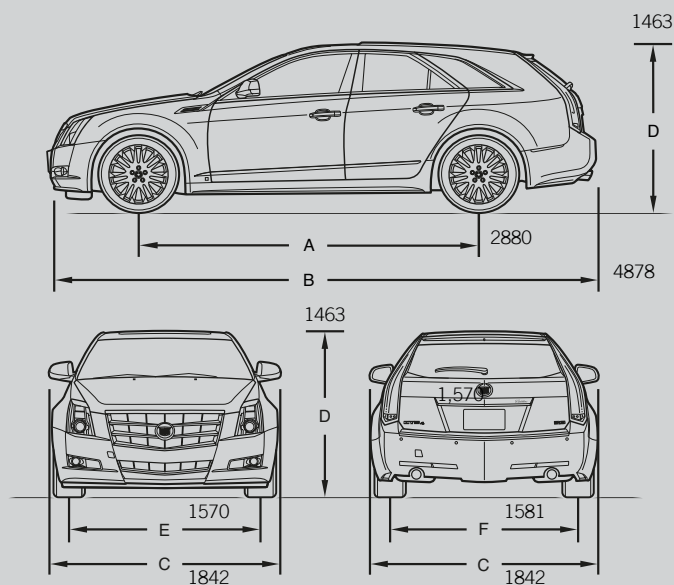

ENGINE:

3.0L V6 'ELEGANCE':

- Variable valve timing and Direct Injection petrol engine
- Maximum power (kW): 203
- Maximum power (hp): 276
- Maximum torque (Nm): 302
- Top speed in km/h: 225
- Acceleration 0–100 km/h (s): 8.2
- Fuel consumption:
 - urban: 14.5 l / 100 km
 - extra-urban: 7.3 l / 100 km
 - combined: 9.9 l / 100 km
- CO₂ emissions combined: 233 g/km

3.6L V6 'SPORT LUXURY':

- Variable valve timing and Direct Injection petrol engine
- Maximum power (kW): 237
- Maximum power (hp): 322
- Maximum torque (Nm): 372

RWD HYDRA-MATIC 6-SPEED
AUTOMATIC TRANSMISSION:

- Acceleration 0–100 km/h (s): 6.3
- Top speed in km/h: 241
- Fuel consumption:
 - urban: 15.5 l / 100 km
 - extra-urban: 7.5 l / 100 km
 - combined: 10.4 l / 100 km
- CO₂ emissions combined: 245 g/km

AWD HYDRA-MATIC 6-SPEED
AUTOMATIC TRANSMISSION:

- Acceleration 0–100 km/h (s): 6.7
- Top speed in km/h: 225
- Fuel consumption:
 - urban: 15.6 l / 100 km
 - extra-urban: 7.8 l / 100 km
 - combined: 10.6 l / 100 km
- CO₂ emissions combined: 250 g/km

FUEL EFFICIENCY CATEGORY:

3.0L V6 'ELEGANCE':

BE: F
CH: G
DE: G
DK: G
LU: F
NL: G
UK: L

3.6L V6 RWD 'SPORT LUXURY':

BE: F
CH: G
DE: G
DK: G
LU: F
NL: G
UK: L

3.6L V6 AWD 'SPORT LUXURY':

BE: G
CH: G
DE: F

DK: G
LU: G
NL: G
UK: L

WHEELS:

3.0L V6 'ELEGANCE':

- 18"x 8" aluminum wheels with premium multi-coat painted finish
- P235/50 R18 V-rated tires

3.6L V6 'SPORT LUXURY':

RWD models:

- 19"x 8.5" aluminum wheels with high-polished finish
- P245/45 R19 Y-rated tires

AWD models:

- 18"x 8" aluminum wheels with high-polished finish
- P235/50 R18 V-rated tires

DIMENSIONS IN MM:

Exterior length: 4878

Height: 1463

Width: 1842

Wheelbase: 2880

Track width front: 1570

Track width rear: 1581

FURTHER DIMENSIONS:

Turning radius (m): 10.96

Cargo volume (l): 412–1484

Fuel tank (l): 68

CTS ADVANTAGES

DRIVING DYNAMICS

Nürburgring-Tuned Chassis:

Tested and retested on the Nürburgring Nordschleife – one of the most demanding and challenging stretches of road on the planet – the CTS chassis enables the perfect balance of performance and luxury while delivering grip by the truckload.

Performance Suspension System:

All models feature an independent short/long arm front suspension system, with performance characteristics optimized by low-mass aluminum. Multi-link rear suspension with a fully isolated subframe contributes to a superior ride with excellent handling.



StabiliTrak:

By comparing driver steering input with vehicle response, the StabiliTrak electronic stability control system helps you maintain control by quickly applying ABS brakes to any wheel and adjusting the power through traction control to help correct oversteer or understeer.



"Maybe the best American car ever made". High praise indeed for Cadillac's performance credentials from esteemed US automotive magazine, 'Car and Driver'. The Cadillac CTS was put on their prestigious '10 Best Cars' list for 2010. And that is the third year running. The reason? Performance. Sure, our mixture of unapologetically expressive styling and modern luxury is important when competing in this segment, but, at the end of the day, it is all about sheer driving performance.



CTS ADVANTAGES

TOURING PACKAGE

THE UPGRADE FOR
PERFORMANCE-ORIENTED CTS DRIVERS.

The Touring Package is available in the 3.6L V6 Sport Luxury Rear-wheel Drive (RWD) versions and features Recaro 14-way adjustable performance seats and Midnight Sapele wood interior trim. The sueded steering wheel, shift knob and seat inserts give the cockpit an even sportier look, and more importantly: give you the increased grip and hold you need when you when you are driving fast on challenging roads. Metal pedals and the exclusive Dark Spinele grille finish round out the package. And on the exterior, a CTS Sedan or Sport Wagon equipped with the Touring Package signals its ambition with distinguished chrome door handles.



CTS ADVANTAGES

SAFETY

Passenger safety is always the first and most important consideration in the Cadillac engineering process.

All CTS vehicles are painstakingly designed to provide a host of features to ensure that accidents are avoided in the first place and, crucially, to protect driver and passengers should impact occur.

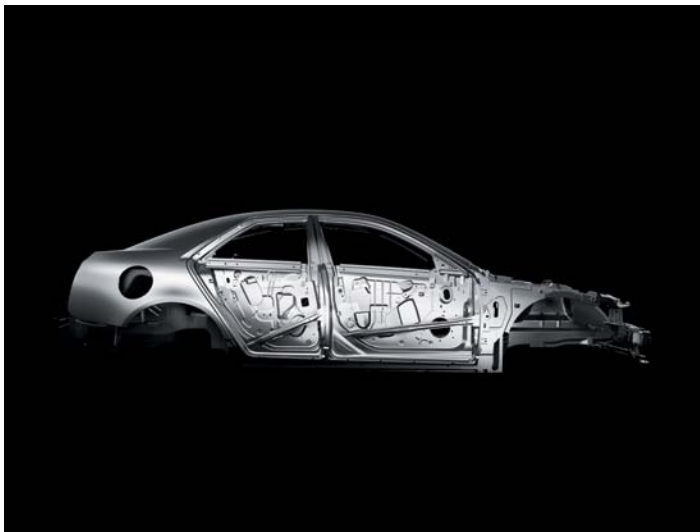

Strong Body Unit:

Strategically engineered crumple zones surround all occupants. Both front and rear zones help absorb impact forces, and comprehensive use of high-strength steel helps to direct energy away from the passenger compartment.

Six Airbags:

Dual-stage frontal airbags and seat-mounted side airbags for the driver and front passenger. Head/curtain side-impact airbags mounted at the roof rail help protect both front and outboard rear passengers in the event of a side impact.

Tire Pressure Monitor:

A sensor in each tire constantly monitors air pressure. Should there be a drop in pressure, the driver will receive an alert via the Driver Information Center.

CTS-V



CTS-V

SUPERIOR PERFORMANCE

Looking for two of the fastest V8 production vehicles on the planet? Then have a look at these numbers. 564 hp. 747 Nm of torque. 0 to 100 km/h in 4.0 seconds. Clocking an astonishing 7:59.32, the CTS-V Sedan is the first 4-door on street tires to break the legendary 8-minute barrier at the Nürburgring Nordschleife. And it is not surprising given the CTS-V's performance-oriented specifications. Vented Brembo brakes. 6-speed manual or Hydra-Matic electronically controlled automatic transmission with steering-wheel-mounted paddle shifters. 14-way adjustable Recaro performance-driving seats. Magnetic Ride Control suspension system. The groundbreaking CTS-V Sedan, Coupe and Sport Wagon. Look no further.



CTS-V SEDAN

EXTERIOR

Adaptive Forward Lighting:

Turn night into day. High-Intensity Discharge (HID) headlamps with Adaptive Forward Lighting light corners when the sun goes down. The stacked headlamps swivel up to 15° in the direction of travel, thanks to intelligent sensors that read speed and steering angle.



Wheels:

V-series 19" aluminum wheels with a premium multi-coat painted finish come together with P255/40R19 front tires and P285/35R19 rears, working seamlessly with the CTS-V Sedan's performance brake and cooling systems. The same wheels are also available in a highly polished finish.



Take a regular CTS Sedan, add a 6.2L supercharged V8, track-tuned suspension dynamics and an impressive array of performance-oriented technical control systems, and you are well on your way to creating a true world-beater.

Outwardly, the CTS-V Sedan is a more imposing proposition all over – and it is not just for show. To accommodate the larger engine, the hood bulges. The front spoilers may look impressive, but they also act to cool down the high-performance braking system. Side-skirts force the car onto the road, improving cornering and grip levels. The mesh frontal grilles allow more air intake for the engine and clearly communicate the character of the CTS-V as that of a true performance vehicle.



CTS-V COUPE

EXTERIOR

The CTS-V Coupe. Aside from the number of doors, the CTS-V Coupe is everything the Sedan is and more. The Coupe is 41 mm wider than the Sedan, enabling an extra measure of handling capability, while adding to the car's aggressive looks. The unique centered twin pipes further add to the Coupe's imposing stance.

The one thing that has not changed is that 6.2L supercharged V8, the MRC suspension dynamics, and all that technical control wizardry.

The CTS-V Coupe. 2-door intoxication.



Coupe Style:

The CTS-V Coupe retains the same racy wheel dimensions of the CTS-V Sedan, but has a shorter overall height and length. The CTS-V Coupe, of course, also has two doors less, creating a visual appeal that you just cannot quantify.



Auto-Touch Door Releases:

Keyless, touchpad door releases are almost invisible and accentuate the CTS-V Coupe's clean lines. A personalized fob unlocks the car when the touchpad is activated or when the deck-lid button is pressed. The remote start system can start the engine from as far away as 60 meters.

CTS-V SPORT WAGON

EXTERIOR

Adaptive Forward Lighting:

Turn night into day. High-Intensity Discharge (HID) headlamps with Adaptive Forward Lighting light corners when the sun goes down. The stacked headlamps swivel up to 15° in the direction of travel, thanks to intelligent sensors that read speed and steering angle.



Power Liftgate:

A power liftgate with memory height position allows rear hatch opening height to be preset. Floor rails are fitted with attachment points for tie-downs.



The standard for sport wagons has been raised once again. We should probably warn the competition – but with the CTS-V Sport Wagon the competition is pretty much over. This is no ordinary high-performance wagon. It is arguably the fastest production wagon on the planet. The most powerful engine in Cadillac's history: a 564 hp (415 kW) supercharged 6.2L V8 propels this head-turner to 100 km/h in 4.1 seconds. Thankfully, the V-Wagon also shares the CTS-V Sedan's track-tuned chassis and revolutionary dual-mode Magnetic Ride Control suspension system to assure that it holds the road like no other car in its class. With its stunningly appointed interior, breathtaking performance and 1,484 liters of cargo space, the all-new CTS-V Sport Wagon simply does not have any serious competition.



CTS-V INTERIOR

Infotainment:

A 40 GB infotainment center incorporates a Bose® 5.1 audio system and navigation system as standard. Its LCD screen, which glides up out of the dash, delivers 800 x 480 pixel color resolution and even displays MP3 playlists through USB and auxiliary audio jacks.



Performance Instrumentation:

The G-meter in the driver information center measures lateral acceleration and remembers maximum acceleration left and right. The full dash instrumentation features LED tracers that flash as you approach the redline. The driver-focused switch array puts everything you need right at your fingertips.

Control meets comfort. Perforated and sueded microfiber seat inserts keep you firmly planted during performance driving, and the sueded steering wheel and shift knob help with control. Just like every CTS, major aspects of the cabin are cut and sewn by hand. The V-Series includes a leathered instrument panel, door trim and center console for a finely tailored interior. Standard RECARO performance seating with 14-way adjustable pneumatic bolster controls offers firm back and thigh support for the driver and front-seat passenger.



CTS-V DRIVING DYNAMICS

Magnetic Ride Control:

Using shocks controlled by electromagnets greatly accelerates response time. Electronic sensors at all four wheels literally read the road, making constant and virtually instantaneous adjustments to damping that lead to extremely precise control of body roll.

Braking & Tire Systems:

The CTS-V's sports race-bred Brembo brakes at all four corners of the car include powerful, six-piston calipers in the front and four-piston calipers in the rear. The car sits on a custom version of Michelin's new Pilot Sport PS2 tires developed specifically for the CTS-V.



Limited-Slip Differential:

The Nürburgring-tuned rear-wheel drive platform features advanced limited-slip differential with 'Positraction' axle. The system allows torque to be distributed as needed to either one of the rear wheels, ensuring that every last ounce of available grip is exploited.



The 6.2L LSA supercharged V8s generate 564 hp (415 kW) and 747 Nm of torque. And they deliver this power with remarkable refinement. A sixth-generation Eaton supercharger minimizes the added noise previously associated with supercharged engines, and regulates intake air temperatures for optimal performance. Manual transmission comes courtesy of a Tremec® aluminum alloy TR6060 6-speed gearbox with short-throw shifter, dual-disk clutch and removable shift fork wear pads. With the 6-speed automatic comes a torque converter clutch, performance shifting and clutchless manual operation using steering-wheel-mounted paddles. The CTS-V's chassis itself delivers outstanding performance – the tuning and orchestration of its elements having been tested and retested on one of the most challenging stretches of road on the planet, the Nürburgring Nordschleife.



CTS-V

TRIM LEVELS & EQUIPMENT



THE CTS-V SEDAN, COUPE AND SPORT WAGON INCORPORATE SOME OF THE INDUSTRY'S BEST LUXURY ATTRIBUTES, ADVANCED TECHNOLOGIES AND ELECTRONICS.

HIGHLIGHTS OF STANDARD EQUIPMENT:

- High-performance 6.2L supercharged V8 engine (415 kW / 564 hp)
- Sport suspension with Magnetic Ride Control
- Performance brake and cooling system
- Y-rated performance P255/40 R19 front and P285/35 R19 rear tires
- Tire pressure monitor system with sensors in each tire
- 6-speed manual or 6-speed Hydra-Matic automatic transmission may be chosen
- Steering-wheel-mounted paddle shift controls for Hydra-Matic transmission
- Power rake wheel and telescopic steering column
- Leather seating
- Recaro driver and front passenger seats with 14-way power adjustment
- Heated and ventilated front seats featuring perforated leather and head restraints
- Air-conditioning with dual-zone automatic climate control and individual climate settings
- Bose® audio system with HDD-based navigation, CD player, 5.1 cabin surround, USB port, and integrated voice control
- Rear-view camera system
- Rear Parking Assist, ultrasonic with audible warning chimes
- Theft-deterrent alarm system
- Accent lighting
- Sueded steering wheel and shift knob

- Keyless access – passive entry, keyless ignition
- Automatic cabin odor filtration
- Trunk cargo convenience net
- Memory package
- Limited-slip differential

DIFFERENCES IN STANDARD EQUIPMENT:

CTS-V Sedan and CTS-V Sport Wagon:

- V-series standard painted aluminum wheels, 19" x 9" front, 19" x 9.5" rear

CTS-V Coupe:

- V-series premium multi-coat painted wheels, 19" x 9" front, 19" x 10" rear

OPTIONAL EQUIPMENT FOR ALL MODELS:

- Wood trim package (Real Midnight Sapele wood on instrument panel, center console door trim, including heated steering wheel)

MODEL SPECIFIC OPTIONAL EQUIPMENT:

CTS-V Sedan and CTS-V Sport Wagon:

- V-series polished wheels, 19" x 9" front, 19" x 9.5" rear
- Power UltraView double-sized sunroof with express-open and power sunshade

CTS-V Coupe:

- V-series high polished wheels, 19" x 9" front, 19" x 10" rear
- Power tilt-to-open sunroof with power sunshade
- Ebony Nuance leather seats with Saffron interior accents

CTS-V

TECHNICAL INFORMATION

ENGINE:

- 6.2L supercharged V8 engine
- Maximum power (kw): 415
- Maximum power (hp): 564 @ 6,100 rpm
- Maximum torque (Nm): 747 @ 3,800 rpm
- Compression ratio: 9.1:1 nominal
- Valvetrain: overhead valve, two valves/cylinder; 12.5 mm lift
- Ignition system: direct-mount ignition coils; extended-life dual platinum-tipped spark plugs
- Firing order: 1-8-7-2-6-5-4-3
- Bore x stroke (mm): 103 x 92
- Fuel system: sequential fuel injection
- Block: cast aluminum
- Cylinder head: cast aluminum
- Crankshaft: steel, 8-bolt flange
- Camshaft: hydraulic roller-type, low lift
- Connecting rods: powder metal
- Additional features: pan-mounted oil cooler; cast pistons; high-flow cylinder heads; block-mounted piston squirters; close-mounted converters; acoustic engine cover; E67 engine controller

Information valid for all CTS-V models

'CTS-V SEDAN' AND 'COUPE':

RWD, 6-SPEED

MANUAL TRANSMISSION:

- Top speed in km/h: 308
- Acceleration 0–100 km/h (s): 4.0
- Fuel consumption:
 - urban: 22.4 l / 100 km
 - extra-urban: 11.5 l / 100 km
 - combined: 15.6 l / 100 km
- CO₂ emissions combined: 365 g/km
- 6-speed, Tremec® TR-6060 manual gearbox
- Gear ratios 1st: 2.66; 2nd: 1.78; 3rd: 1.30; 4th: 1.00; 5th: 0.80; 6th: 0.63; reverse: 2.90; final drive: 3.73

CTS-V SPORT WAGON':

RWD, 6-SPEED

MANUAL TRANSMISSION:

- Top speed in km/h: 308
- Acceleration 0–100 km/h (s): 4.1
- Fuel consumption:
 - urban: 22.6 l / 100 km
 - extra-urban: 11.7 l / 100 km
 - combined: 15.7 l / 100 km
- CO₂ emissions combined: 370 g/km
- 6-speed, Tremec® TR-6060 manual gearbox
- Gear ratios 1st: 2.66; 2nd: 1.78;

3rd: 1.30; 4th: 1.00; 5th: 0.80; 6th: 0.63; reverse: 2.90; final drive: 3.73

'CTS-V SEDAN' AND 'COUPE':

RWD, 6-SPEED

AUTOMATIC TRANSMISSION:

- Top speed in km/h: 282
- Acceleration 0–100 km/h (s): 4.0
- Fuel consumption:
 - urban: 21.3 l / 100 km
 - extra-urban: 10.7 l / 100 km
 - combined: 14.4 l / 100 km
- CO₂ emissions combined: 336 g/km
- 6-speed Hydro-Matic gearbox; electronically controlled, automatic overdrive transmission with torque converter clutch, performance algorithm shifting and Driver Shift Control (DSC) for clutchless manual operation
- Steering-wheel-mounted paddle shift controls
- Gear ratios 1st: 4.02; 2nd: 2.36; 3rd: 1.53; 4th: 1.15; 5th: 0.85; 6th: 0.67; reverse: 3.06; final drive: 3.23

'CTS-V SPORT WAGON':

RWD, 6-SPEED AUTOMATIC

TRANSMISSION:

- Top speed in km/h: 282
- Acceleration 0–100 km/h (s): 4.1
- Fuel consumption:
 - urban: 21.3 l / 100 km
 - extra-urban: 10.8 l / 100 km
 - combined: 14.5 l / 100 km
- CO₂ emissions combined: 343 g/km
- 6-speed Hydro-Matic gearbox; electronically controlled, automatic overdrive transmission with torque converter clutch, performance algorithm shifting and Driver Shift Control (DSC) for clutchless manual operation
- Steering-wheel-mounted paddle shift controls
- Gear ratios 1st: 4.02; 2nd: 2.36; 3rd: 1.53; 4th: 1.15; 5th: 0.85; 6th: 0.67; reverse: 3.06; final drive: 3.23

FUEL EFFICIENCY CATEGORY:

ALL CTS-V models:

BE: G
CH: G
DE: G
DK: G
LU: G
NL: G
UK: M

CHASSIS AND SUSPENSION:

Weight distribution:
54% front / 46% rear

PERFORMANCE CHASSIS:

Performance-tuned dual-mode
Magnetic Ride Control suspension
system

Front:

- Independent, short/long arm
- 29 mm hollow stabilizer bar
- Elastomeric handling and ride bushings
- 65-N/mm spring rate

Rear:

- Independent, short/long arm
- 24 mm solid stabilizer bar
- Elastomeric trailing arm bushing
- 90-N/mm spring rate

Limited-slip differential with
'Positraction' axle

ZF Servotronic® 2.5 steering;
speed-sensitive, power-assisted
rack-and-pinion; variable ratio

Traction control system; all-speed
with brake and engine intervention

StabiliTrak electronic stability control system; 4-channel, computer-controlled, four driver-selectable modes

Brembo® high-performance brakes; aluminum 6-piston front, 4-piston rear caliper disc brakes with vented 15" rotors front, 14.7" rotors rear, power-assist with 4-channel ABS

WHEELS:

Sedan and Sport Wagon:

- Painted aluminum wheels, 19"x 9" front, 19"x 9.5" rear
- Y-rated performance P255/40 R19 front and P285/35 R19 rear tires

Coupe:

- Premium multi-coat painted wheels, 19"x 9" front, 19"x 10" rear
- Y-rated performance P255/40 R19 front and P285/35 R19 rear tires

DIMENSIONS IN MM:

Sedan:

Exterior length: 4868
Height: 1455
Width: 1842
Wheelbase: 2880
Track width front: 1576
Track width rear: 1586

FURTHER DIMENSIONS:

Turning radius (m): 10.96
Trunk volume (l): 373
Fuel tank (l): 68

Coupe:

Exterior length: 4823
Height: 1400
Width: 1883
Wheelbase: 2880
Track width front: 1576
Track width rear: 1610

FURTHER DIMENSIONS:

Turning radius (m): 10.96
Trunk volume (l): 344
Fuel tank (l): 68

Sport Wagon:

Exterior length: 4878
Height: 1463
Width: 1842
Wheelbase: 2880
Track width front: 1570
Track width rear: 1581

FURTHER DIMENSIONS:

Turning radius (m): 10.96
Trunk volume (l): 412
Fuel tank (l): 68

CTS

EXTERIOR & INTERIOR COLORS

EXTERIOR

RADIANT SILVER
Metallic

OPULENT BLUE
Metallic

BLACK RAVEN
Exterior

CRYSTAL RED
Tintcoat*

WHITE DIAMOND
Tricoat*

THUNDER GRAY
ChromaFlair*

BLACK DIAMOND
Tricoat*

* Premium paints with premium surcharge

INTERIOR CTS RANGE

LIGHT TITANIUM
NUANCE LEATHER SEATS
with Ebony upper accents

EBONY NUANCE LEATHER SEATS
with Ebony upper accents

CASHMERE
NUANCE LEATHER SEATS
with Cocoa upper accents**

CASHMERE
NUANCE LEATHER SEATS
with Ebony upper accents***

** Only available on CTS Sedan &
Sport Wagon

*** Only available on CTS Coupe

INTERIOR CTS - V

LIGHT TITANIUM
NUANCE LEATHER SEATS with
Light Titanium interior accents

EBONY NUANCE LEATHER SEATS
with Ebony interior accents

EBONY NUANCE LEATHER SEATS
with Saffron interior accents****

**** Only available on CTS-V Coupe

ABOUT CADILLAC



Cadillac[®]

CTS SEDAN



CTS COUPE



CTS SPORT WAGON



Cadillac is a statement. A declaration of intent.

Distinctive, expressive and highly original – the new range of Cadillacs are set to turn a lot of heads on the roads of Europe. If you are looking for 'ordinary', you have definitely come to the wrong place.

Spectacular from all angles, Cadillac's new design language is shaking up the reserved world of premium cars in all its segments, from sedans to crossovers and SUVs. And our passion for performance has led to a new generation of luxury vehicles – vehicles created for true driving enthusiasts.

Elegantly combining high-performance handling and road-holding with a thrilling abundance of efficient power, our cars, crossovers, and SUVs are tested and honed on racetracks around the world – including one of the most demanding and challenging stretches of road on the planet, the Nürburgring Nordschleife.

So, if you are looking for distinction and performance, get in.

Welcome to Cadillac.

CTS-V SEDAN



CTS-V COUPE



CTS-V WAGON



CADILLAC ADVANTAGES

WARRANTY & CONTACT

CADILLAC SALES AND SERVICE SPECIALISTS

Whether you are at home or on the road, your Cadillac sales and service specialists are there to offer you truly personal assistance. Count on them to arrange service appointments, answer questions about your new Cadillac and ensure that you are always satisfied with your ownership experience. To find the Cadillac sales and service specialist closest to you, visit www.cadillaceurope.com.

WARRANTY

As a Cadillac owner, you should expect nothing less than premium service and protection, which is why your new Cadillac comes with a full 3-year or 100,000 km warranty (whichever comes first), plus a 6-year rust-through guarantee, all backed by an experienced Cadillac service team that will handle any issues with confidence and due care. For more details, ask your Cadillac sales and service specialist.

CADILLAC ROADSIDE ASSISTANCE

In the event of an emergency, help is only a phone call away. Contact Cadillac Roadside Assistance and they will come to you as quickly as possible - 24 hours a day, 365 days a year. If they can not get you back on the road straightaway, they will drive you to the nearest Cadillac sales and service specialist. Cadillac Roadside Assistance is yours free of charge for a period of 36 months from the date of registration. Ask your local Cadillac sales and service specialist for details.

Fuel consumption/CO₂ emission information is official government environmental data, tested in accordance with the relevant EU Directive. CO₂ is the main reason for global warming. Average CO₂ emission of all new cars sold in Switzerland: 159 g/km.

PLEASE NOTE: The vehicle shown in this brochure is for illustration purposes only. European specifications may vary. Some illustrations feature special equipment that is not included in standard delivery. The information contained in this brochure was accurate at the time of going to press. We reserve the right to make changes in design and equipment. The colours printed in the brochure only approximate actual colours. Illustrated optional equipment is available at extra charge. Availability, technical features and equipment provided on our vehicles can vary from one market to another and may change without prior notice. Information on recycling design and End of Life Vehicles (ELV) can be found on the website www.cadillaceurope.com. For precise information on the equipment provided on our vehicles, please contact your local Cadillac sales and service specialist. © 2012 General Motors. All rights reserved. This material shall not be reprinted, in whole or in part, without the express written permission of General Motors.

<http://www.cadillaceurope.com>

Cadillac Europe, Stelzenstrasse 4, CH - 8152 Glattpark (Zurich)