

The information and images in this brochure are based on the current technical data when going to print. The equipment shown is factory fitted or available as an option at extra cost, depending on the model. Where a feature is described as an option it should be assumed that it is at extra cost unless specifically stated otherwise. There may be some feature combinations that are not available in the UK and some photography may feature left hand drive vehicles. As part of a policy of continuous specification improvement, Peugeot reserve the right to modify the technical equipment, options and colours at any time. For full specification details please refer to the specification leaflet or ask your Peugeot Dealer who will be happy to help. Note that current print and photographic techniques do not allow us to faithfully reproduce the full depth and tone of the colours in this brochure. This brochure is designed to provide general product information and is not a contractual document or offer of sale. For current information please contact your authorised Peugeot Dealer. The details in this catalogue cannot be reproduced without the express authorisation of Peugeot.



The New Peugeot **307 CC**



Création BET C EURO RSCG – Automobiles Peugeot RC Paris B 552 144 503 – Édition : MKD Production (5) – Imprimé en U.E. – GB – 07/03

Issued by: Sales and Marketing, Peugeot Motor Company plc,
Aldermoor House, PO Box 227, Aldermoor Lane, Coventry CV3 1LT.

For details of HM Forces tax-free military sales contact:
Peugeot Export, 454-490 Mile End Road, London E1 4PE.
Telephone: 0207 791 9050
Email: peugeot.export@peugeotmail.co.uk

For all other enquiries please call 0845 200 1234
(calls will be charged at local rate, and may be recorded
for training or quality purposes).

www.peugeot.co.uk

September 2003
MCP 2109



What would you wish for?

307 CC, why limit yourself to three wishes? 4-27

Technology 28-35

Metamorphosis: A retractable steel roof 30-31

Technology: Aesthetics 32-33

Built-in intelligence 34-35

Driving 36-47

Performance: Engines 38-39

Road handling: Control 40-41

Safety: Protection 42-43

Confidence: On the road 44-45

Driving made easier 46-47

Comfort on board 48-59

Interior ergonomics 50-51

Interior personality 52-53

Ergonomics: Life on board 54-55

Upholstery: Individual preference 56-57

Taste: Colours 58-59

Accessories 60-61

The Peugeot Customer Promise 62-63



Would you like
to enjoy more

freedom?

(...)

When you have choices, the roads seem
a little more open. You can head off
wherever the mood takes you, whatever
the weather's like and in the company
of your favourite people.

This concept of freedom is what
inspired the 307 CC, with the virtues
of a sleek convertible and a classic coupé
combined in one beautiful car.



Lama interior will be available later this year.



Lama interior will be available later this year.



Perhaps
you'd appreciate a little more

adaptability?

(+)

If this is what you want,
everything is possible...with
no compromise. The 307 CC is so
flexible – a car that feels as much
at home taking you round town or
cruising through the countryside.
This car is versatile enough to fit
in with your life, however
demanding you are.



(+)



Do you want to feel

reassured?



The 307 CC comes with peace of mind built in. That's because it's the culmination of years of relentless research and technological excellence. You might never push it to the limit, but you'll always know that your new car will get you out of any tight corners, thanks to Peugeot's investment in your safety and our attention to even the smallest detail.



(!)



Could we be more **generous?**

(&)

The 307 CC allows you to include your friends. Its sculpted seats are designed for four adults because we know that the more enjoyment you share together, the happier you'll be.



(&)



How about the promise of

adventure?

The 307 CC is surely one of the most attractive cars on the road today. The dynamic performance* delivered by the range of engines is truly impressive – as is its tenacious road-holding. Turn the key, take it out onto the open road and your response will be as much emotional as physical.



*For details of performance and economy please refer to the 307 CC specification leaflet.



Lama interior will be available later this year.

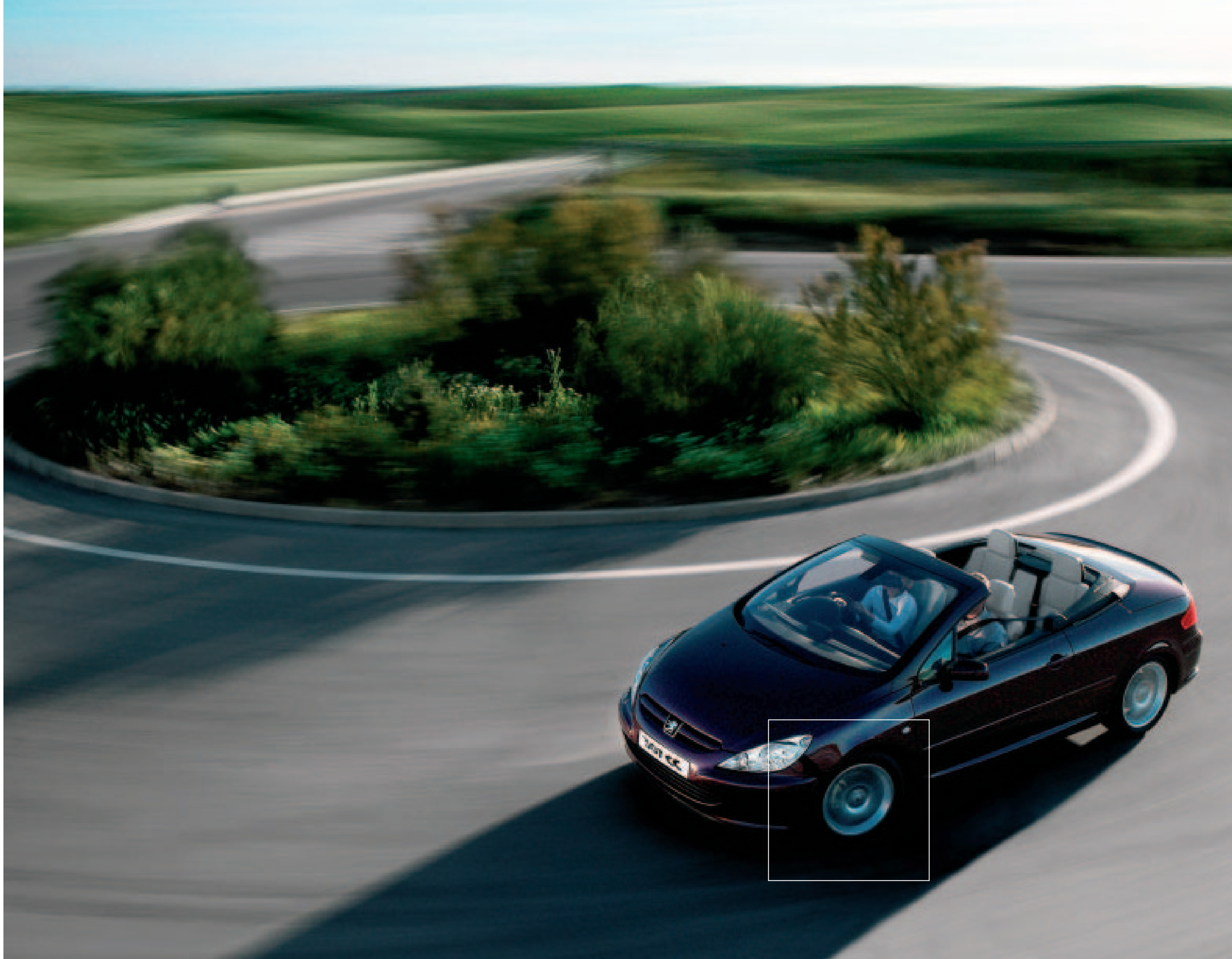

Your wishes
will become reality...



307 CC:
from now on,
things are
going to be
different



Without compromise

307 CC



The new 307 CC gives you performance* and functionality, sportiness and security – all in one beautifully designed package.



*For details of performance and economy please refer to the 307 CC specification leaflet.

Technology

(+)



Driving the 307 CC provides unlimited pleasure, thanks to a combination of technological know-how and design excellence. Peugeot's uncompromising attention to detail is evident everywhere, especially with the introduction of innovative new features.

(+) **Metamorphosis:**
A retractable steel roof



Rigid retractable steel roof

The 307 CC has an integral steel roof that automatically raises and lowers in seconds.

At the simple touch of a button, your sleek coupé can become a classic cabriolet, and vice versa.

Grouped controls

The controls for the roof, together with simultaneous electric operation of all four windows are positioned between the front seats.



25 seconds

(+) Technology:
Aesthetics



Door handle sensors

Capacitors, built in to the door handles, can detect your hand; your movement will trigger a slight lowering of the front windows, so you can open the door more easily.

Rear styling

The 307 CC challenges the accepted norms of car styling; its design is a careful blend of sweeps and arcs that are all intended to draw your eye from the smooth curves of the boot-line to the unmistakable sculpted headlights.



Rear lights

The innovative diode lights, as well as providing outstanding visibility, are arranged in four diagonal bands, emphasising the car's sleek lines.



(+) Built-in intelligence



In-car communication

The 307 CC is designed to keep you in touch with the world outside. In a real feat of technology it brings together in a standard radio unit a complete audio system, an on-board navigation system and a hands-free telephone, with the whole system linked to voice commands.

Emergency assistance

The SOS button is directly linked to the Customer Contact Centre.

It allows you and your car to be located if there's an emergency, so help can reach you quickly.



Audio system

The radio/CD player has six speakers and fingertip controls on the steering wheel to minimise distraction while you're driving.

Phone

The dual-band telephone is incorporated into the dashboard, with steering wheel controls and a microphone for hands-free use.



Satellite navigation

You can have the option of a satellite navigation system, with a black & white or colour screen. Once you've told it where you want to go, it will guide you with vocal and visual directions to your destination.

SMS function

You can also send and receive text messages.





Driving

(!)



Behind the wheel of a 307 CC, you're in control of a car that gives you unqualified driving pleasure, outstanding performance and totally reassuring levels of active and passive safety.

(!) Performance: Engines

The 307 CC is available with a choice of two petrol engines - 2.0 138 bhp or 2.0 180 bhp*.



Manual gearbox

A 5-speed manual gearbox is standard on both models.



Automatic transmission

State of the art technology combines the pleasures of a manual gearbox with the ease of an automatic.

In sequential (manual) mode, the gear selected is held for as long as you want; only with over-revving during acceleration, or the possibility of stalling will the gearbox initiate a gear change automatically.

The driver changes up and down through the gears manually, precisely and rapidly.

In 'autoactive' automatic mode, the gearbox adapts to the drivers' style and conditions, thanks to its ability to recognise inclines and bends.

It will also change down in the event of sharp braking.

You can choose from three programmes:

Auto (normal), Sport (for more dynamic driving) and Snow (which reduces the risk of skidding on a slippery road).



Lama interior will be available later this year.

Consumption in mpg (litres/100 km)

	Urban	Extra Urban	Combined	CO ₂ (g/km)
2.0 litre 138 bhp manual	24.6 (11.5)	45.6 (6.2)	34.4 (8.2)	194
2.0 litre 138 bhp auto	21.6 (13.1)	44.1 (6.4)	31.7 (8.9)	211
2.0 litre 180 bhp*	22.8 (12.4)	41.5 (6.8)	32.1 (8.8)	210

* Production of the 180 bhp engine will begin later this year.



Road handling: Control

Ventilated front discs

The 307 CC is fitted with two large diameter ventilated front disc brakes, giving you high performance braking that you can have total confidence in.

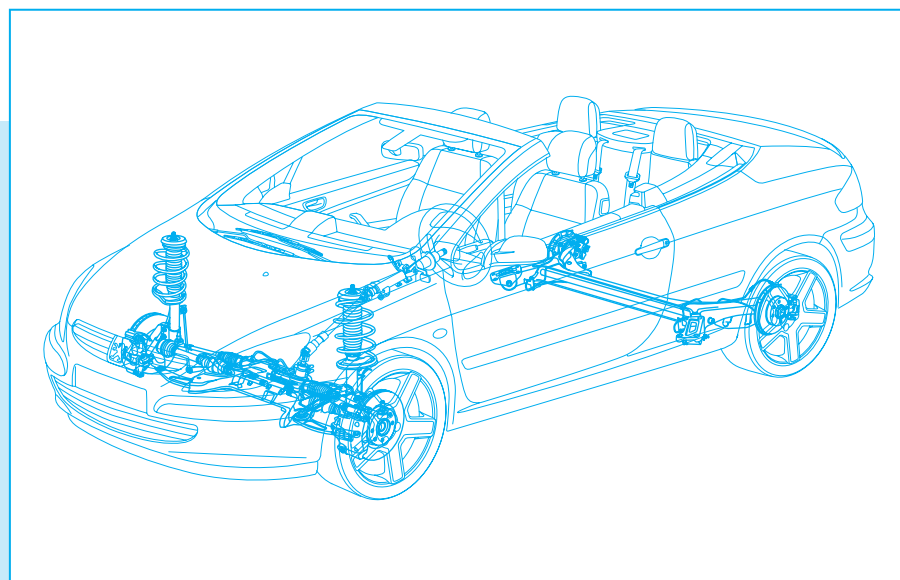

Front suspension

The Pseudo MacPherson front suspension featured on the 307 CC provides superior driving dynamics by optimising the geometry of the front suspension, dampers and steering.

Rear suspension

The 307 CC has a rear suspension system featuring a deformable U-shaped cross-member located by two arms and a hollow anti-roll bar. This helps provide the car with the road-holding capabilities for which Peugeot are renowned.



Aluminium 16" Ariane wheels

(standard on the 2.0 litre 138 bhp)



Aluminium 17" Challenger wheels

(standard on the 2.0 litre 180 bhp and optional on the 2.0 litre 138 bhp)



(!) Safety: Protection

Roll-over hoops

In the event of an accident, a gravity switch can detect the possibility of the car turning over. Then, in a fraction of a second, it activates the roll-over hoops to protect your rear passengers.



Two front air bags

The 307 CC is fitted with front airbags for the driver and the passenger (with deactivate switch), to provide optimum protection in the event of an impact. Depending on the severity of the impact, the pressure and the speed of inflation are adapted accordingly.

Two side head and chest air bags

These are built in to the side frames of the front seat backs to give the driver and front seat passenger added protection.

Active seat back

The front seats incorporate a mechanism that allows them to support the movement of your neck to prevent whiplash in the event of an accident.

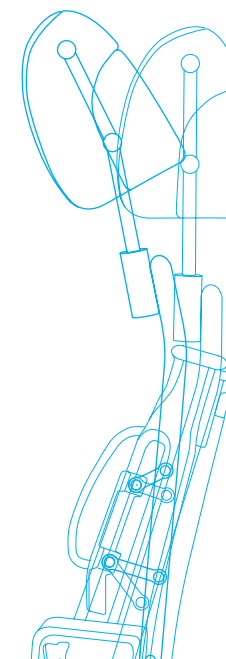

(!) Confidence: On the road

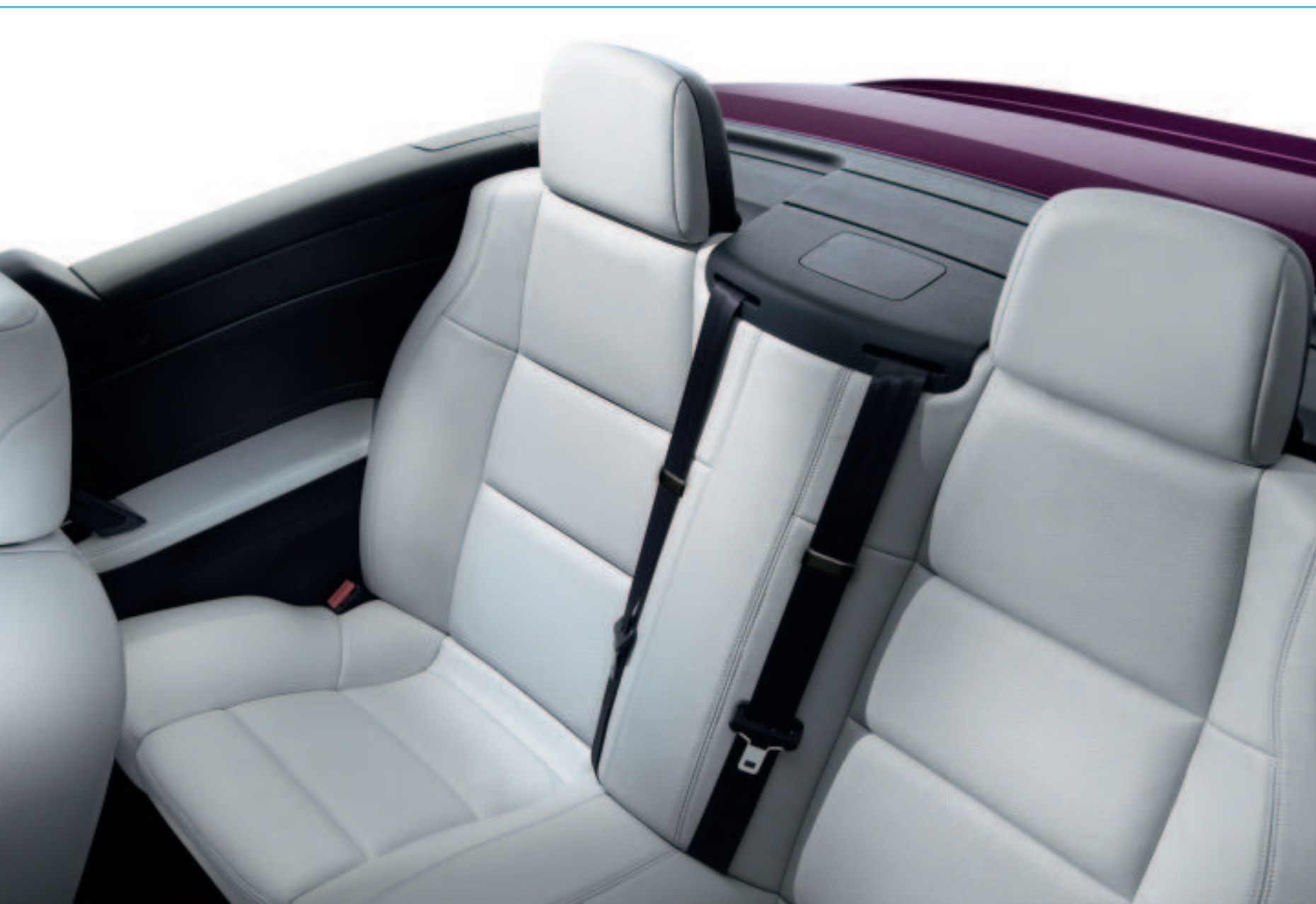

Lama interior will be available later this year.

3-point front and rear seat belts

Each seat is fitted with a 3-point seat belt. The front seat belts are also force limiting and pretensioning.

Inner strength

Structural rigidity is built in to the 307 CC. If there's an accident, the entire passenger compartment remains intact so that you and your passengers are as safe as possible.

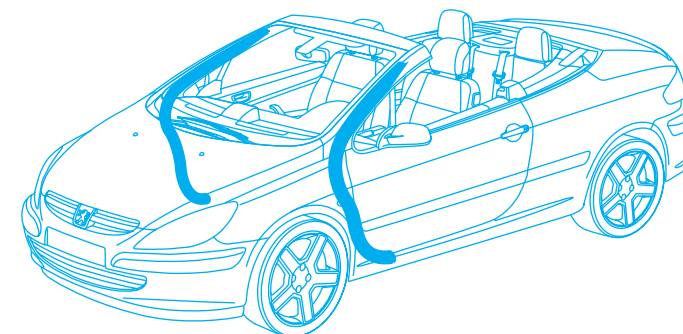

ESP (ELECTRONIC STABILITY PROGRAMME)

This electronic braking offers the driver unobtrusive and very effective assistance.

The system combines four functions: Electronic Brake Force Distribution (EBFD), ABS, Traction Control (ASR) and Dynamic Stability Control (DSC).

- Electronic Brake Force Distribution (EBFD) distributes the brake pressure over the four wheels, depending on the road grip and the vehicle load.
- ABS system prevents any risk of the wheels locking on a slippery surface, allowing the driver to be in control.
- Traction Control (ASR) system prevents the wheels from turning without gripping in slippery conditions.
- Dynamic Stability Control (DSC) makes sure that your car is always perfectly balanced.

A sensor located in the centre of the vehicle compares the direction of the steering wheel with your car's actual direction. If there's a significant variation, the system locks one or more wheels and reduces the engine torque so it's easier to set your car back to its correct course.

Isofix

Both rear seats have Isofix fittings for anchoring a child seat safely and easily.

(!) Driving made easier

Automatic headlights-on¹

The 307 CC features automatic headlights-on, increasing the safety of the occupants and that of other road users. As the level of the exterior brightness may drop on entering a tunnel or a garage, a sensor automatically switches on the dipped headlights. Inversely, the headlights will switch off automatically when a sufficient level of brightness is reached.

The automatic switching on of the headlights is also connected to the windscreen wipers. The driver can override the system through the function stalks attached to the steering column.



Electrically operated door mirrors

The adjustable side mirrors fold back electrically and incorporate a demisting function.



Automatic rain sensing front wipers¹

The windscreen wipers consist of two strong wiper arms fitted with a deflector to improve effectiveness. Their "butterfly" movement sweeps a large surface area and adjusts its timing to the intensity of the rainfall. This ensures optimum visibility, day and night.



Electrochromic rear view mirror¹

The interior rear-view mirror in your 307 CC is light sensitive. Thanks to two sensors that detect the difference in light levels between the front and rear of the vehicle, the mirror darkens or brightens automatically, preventing any dazzle.



Cruise control²

The cruise control allows you to maintain a constant speed without having to touch the accelerator. If you're on a long drive, you'll soon appreciate how less stressful your journey can be. It's simple to operate and any pressure, on any pedal, is enough to cancel it.



Variable power steering

The assistance provided varies in accordance with the vehicle speed and the force exerted on the steering wheel, making parking easier and giving more precision and firmness when there is an increase in speed. The electronic control of the variable power steering also enables fuel consumption^{*} to be reduced.

¹Standard on 180 bhp model.

²Standard on automatic, option on manual models.

*For details of performance and economy please refer to the 307 CC specification leaflet.

Comfort on board (&)



The 307 CC is the perfect combination of comfort and design.

The interior is much more spacious than you'd expect; it has been carefully designed to provide you and your passengers with maximum comfort.

With a wide choice of body colours and interior trims you can personalise your car.

(&) Interior ergonomics

2 sculpted rear seats with armrests

The carefully designed and supportive rear seats easily accommodate two adults.



Comfort and brightness

Armrests add to the overall feeling of well-being.

The front seats are ergonomically designed and the panoramic windscreen, with its 2.61m² of glass, gives the car an extraordinary feeling of spaciousness.

Driving position

The front seats in the 307 CC are adjustable for height, legroom and seatback tilt.

The steering wheel is also adjustable for rake and reach, offering a truly comfortable driving position.

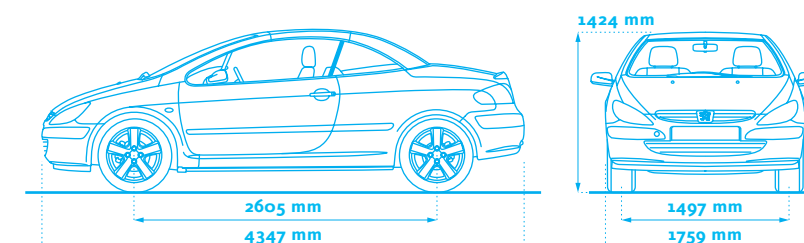

(&) Interior personality

Instrument panel

The four striking white dials are easy to read, and the chrome surrounds add to their sporty appearance.



Automatic air conditioning

The temperature of the passenger compartment is regulated automatically by controlling the flow, distribution and entry of air via a digitally displayed air-conditioning unit. However, manual adjustment of these components is still possible.

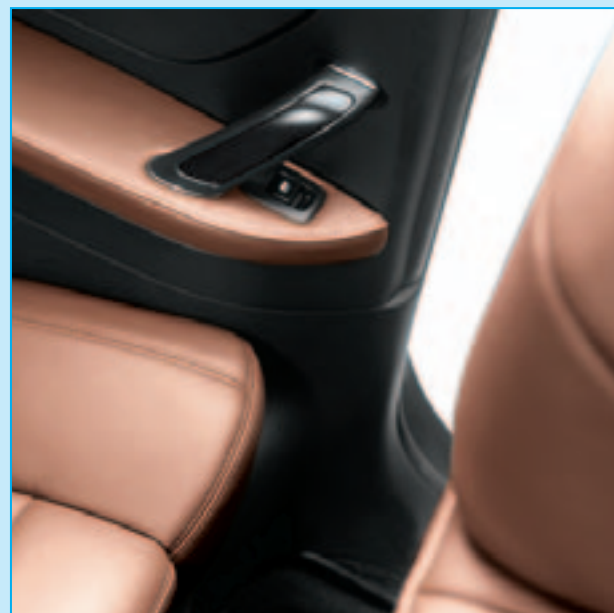

Rear seat handles

The rear armrests have electric rear window controls and handles that make it easier to get in and out of the car.

Leather steering wheel

The steering wheel is superbly designed, with leather and burnished aluminum trim.



Foot pedals

The aluminum pedals are drilled for extra grip and add to the 307 CC's sporty feel.





Ergonomics: Life on board

Boot

The flat, square boot is practical and generous; with the roof up, it has a volume of 350 dm³* – and even as a cabriolet it still has 204 dm³ of space.

*Manufacturer's method



Hinged rear screen

In Cabriolet form, in order to give you the largest possible loadspace, the roof folds just above the rear window. By using a hinge mechanism when the roof is stored, there's still plenty of room for luggage.



Glove compartment

The glove-box lid has various sections for credit cards, glasses, loose change, pens and mobile phones. It's also connected to the air conditioning, so cold drinks stay cool.



Cup holders

There's more thoughtful storage space between the front seats.



Seat pockets

Behind the front seats are pockets for your passengers to store magazines or maps.



Door storage

The door panels have electrical controls and storage compartments, yet they still retain the fluid curves which make the 307 CC so distinctive.

(&)

Upholstery: Individual preference



Apicula

A special sports ambience is available on the 2.0 180 bhp model combining Astrakan Black leather, Apicula mesh fabric and an 'Aluminium-effect' strip across the seat back.

Integral leather interior* consists of leather trimmed dashboard,



Titan ambience: Astrakan Black leather.

door panel cappings, armrests and seats.



Palimbro ambience: Palimbro Brown leather.



Fusion ambience: Salsa Red and Astrakan Black leather.



Lama ambience** : Lama Grey leather - perforated on seats, smooth on bolsters and headrests.

Leather seats*



Titan ambience:
Door panel cappings and fascia binnacle in black. Seats and armrests in Astrakan Black leather.



Fusion ambience:
Door panel cappings and fascia binnacle in black. Seats in two-tone Salsa Red and Astrakan Black leather, and armrests in Salsa Red leather.



Lama ambience:**
Door panel cappings and fascia binnacle in black. Seats in perforated Lama Grey leather. Bolsters, headrests and armrests in smooth Lama Grey leather.

Seats in Andorra woven fabric



Titan ambience:
Door panel borders and fascia binnacle in black. Seats in Andorra woven fabric with bolsters, headrests and armrests in Efka black cloth.

* Integral leather or leather seats are options at extra cost.

** Lama interior will be available later this year.



Taste: Colours

- 1- Babylon Red¹
- 2- Slate²
- 3- Mulberry³
- 4- Iron Grey³
- 5- Flamenco Red
- 6- Aegean Blue³
- 7- Aluminium²
- 8- Onyx Black³

¹ Special paint

² Metallic paint

³ Pearlescent paint

Metallic, pearlescent or special paint is an option at extra cost.



5



6

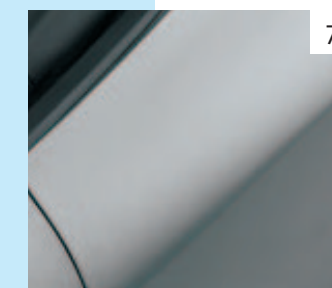

7



1



2



3

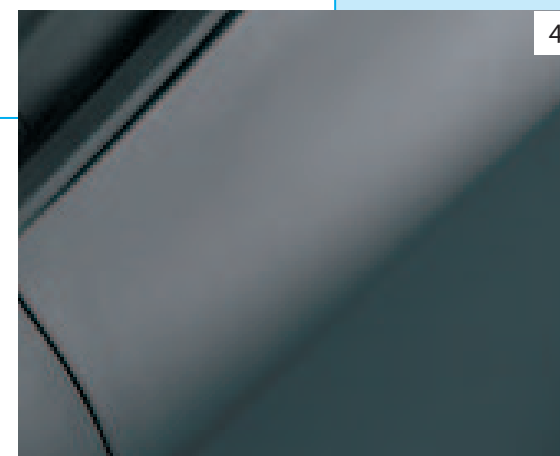

4

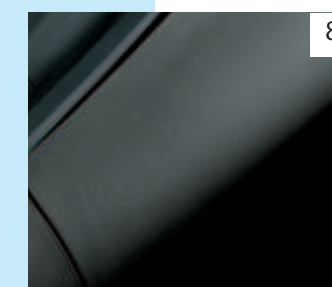

8



Accessories

What else might make you happy?

These are just a few of the accessories that have been designed specifically for the 307 CC. They are all produced or selected by the Peugeot Design Studio, and intended to make even more of the car's space, elegance and comfort.

There's only room to show a small selection here but, if you'd like to see the full range, the 307 CC Accessories brochure is available from your dealer.

Luggage rack

Made from chrome plated stainless steel, the luggage rack is easy to fit and, once in position, blends smoothly with the 307 CC's sleek lines. (available at the end of 2003)



Windstop

Made from lightweight mesh, this specially designed windstop reduces windflow when the roof is down. It comes with its own cover and can be folded into the boot.



Aidel 17" wheel

These 17" alloy wheels have been specifically developed for the 307 CC.





The Peugeot Customer Promise

When you buy a new Peugeot vehicle from a Peugeot Dealer in the UK and entrust your vehicle to one of them for servicing or repair, they promise: to give you the best people, with the best training and diagnostic tools, Genuine Peugeot parts and the best aftersales backup, all at a competitive price.

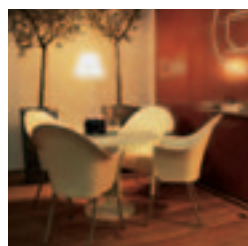
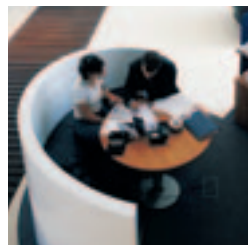

▶ Peugeot Peace of Mind

Peugeot vehicles are designed and manufactured to give you worry-free motoring and peace of mind. As a Peugeot owner you are entitled to a comprehensive range of customer care services from your Peugeot Dealer who has the expertise to maintain your Peugeot to its peak performance.

▶ 3 Years of Warranty

In addition to the 2 year unlimited mileage manufacturer's Warranty, all vehicles first registered in the UK and purchased from a UK Peugeot Dealer benefit from a free optional additional 1 year of Warranty provided by the Peugeot Dealer network in the UK. This optional Warranty is offered free of charge but subject to the manufacturer's recommended servicing being carried out by an authorised Peugeot Dealership. This additional Warranty carries a mileage limit of 60,000 miles (100,000 miles for Boxer models excluding Motorhomes and other converted vehicles) from first registration. The conditions of the additional 1 year Warranty are identical to those of the 2 year manufacturer's Warranty. (For full terms and conditions, please consult your Peugeot Dealer. NB: This 3 years of Warranty is automatically transferable on the sale of the vehicle.)

▶ 12 Year Anti-Perforation and 3 Year Paint Warranty

Also automatically transferable on sale of the vehicle, this will maintain and enhance the resale value of your vehicle. (The Anti-Perforation Warranty is limited to 6 years and the Paint Warranty to 2 years on 206 Van, Partner, Expert and Boxer vans.)

▶ Peugeot Extended Warranty

Should you need protection beyond the initial 3 years of Warranty, the Peugeot Extended Warranty plan can give you cover of up to 120,000 miles or 4 to 5 years on cars, or 4 years with unlimited mileage on Partner, Expert, Expert Combi and Boxer vans. Available as an option at extra cost, the Peugeot Extended Warranty is one of the most competitive schemes of its type and is available exclusively to Peugeot owners. Please ask your Dealer for full details.

▶ Peugeot Assistance

For the first year of ownership you will automatically receive Peugeot Assistance cover for complete peace of mind. Additional Peugeot Assistance may be purchased for the second and third years. Operated by the RAC, it includes roadside assistance, vehicle recovery, free replacement vehicle or hotel accommodation and chauffeur provision in case of certain medical disabilities. Peugeot Assistance is available within the UK and Europe. Your local Peugeot Dealer has full details of terms and conditions.

▶ Peugeot Service Care

Peugeot petrol engine vehicles need servicing every 20,000 miles or every 2 years, whichever is sooner. Drivers of diesel versions also benefit from extended servicing with 12,000 miles (10,000 non HDi diesel vehicles) or 2 year intervals. With less time spent in the maintenance bay and fewer service visits, Peugeot have passed on the benefits of technology in engine design and lubrication. Cost savings, compared to competitive models, increase with mileage covered, and could be up to 45%.

In order to minimise the inconvenience associated with normal servicing, Peugeot UK Dealers promise to offer you the choice of:

- while you wait servicing with a timed appointment;
- or local vehicle collection from your home or place of work;
- or alternative transport to the railway station, home or place of work;
- or by arrangement, a hire vehicle at a concessionary rate.

In addition they will aim to ensure that your vehicle is washed before it is returned.

▶ Peugeot Insurance Centre

Peugeot Insurance has been specifically arranged for Peugeot owners. Offering discounted premiums and a fast and efficient claims service, it is another benefit of owning a Peugeot. Your Dealer can provide a proposal form for a free quotation or you can call the Peugeot Insurance Centre direct on **0845 200 1234** for a free quotation.

Alternatively, contact:
Peugeot Insurance Centre
The Wharf
Neville Street
Leeds
LS1 4AZ

Whatever Peugeot you drive, we guarantee you a competitive premium for your Motor Insurance. As a valued customer of Peugeot we'll make sure you get the very best premium quotation possible from Peugeot Insurance.