

May 2009

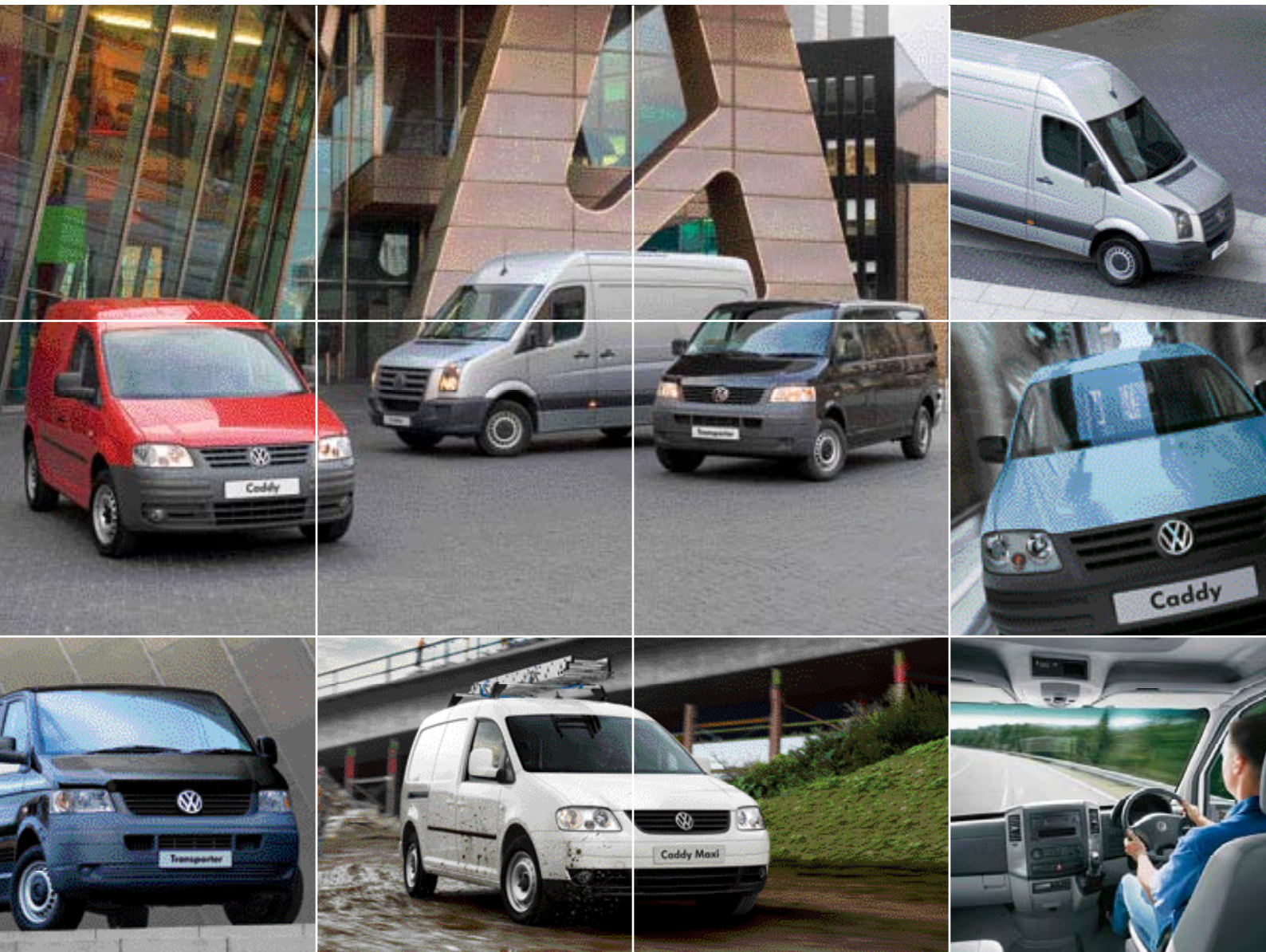

Commercial
Vehicles

Panel vans



Welcome.



Over the years, we've worked hard to establish Volkswagen Commercial Vehicles as a dependable, well-respected Brand. There is an indefinable robustness that distinguishes both our products and our organisation from others. It's founded in the twin reality of premium quality vehicles on the road, and down-to-earth assistance in our day-to-day dealings with our customers. We want you to have the confidence that wherever you are, whatever business you're in, Volkswagen can be relied on to deliver.

But we're not complacent. We are still working to improve our network of Van Centres, the product range and, of course, the level of customer care. We want to help you find the right vehicle for your business, and the right level of support for you. So if you need assistance, please, just ask.



Contents.



02 - 07
Welcome to Volkswagen Commercial Vehicles, introduction and importantly your quick reference guide.



08 - 13
The panel van range – which model is for me?



14 - 15
A summary of the panel van range.



16 - 29
The Volkswagen Caddy and Caddy Maxi, standard specifications, prices, factory options and technical data.



30 - 45
The Volkswagen Transporter panel van, standard specifications, prices, factory options and technical data.



46 - 61
The Volkswagen Crafter panel van, standard specifications, prices, factory options and technical data.



62 - 65
Paint and upholstery for the panel van range and a comprehensive choice of Volkswagen Commercial Vehicle accessories.

















66 - 71
Services, warranties, our dedicated Van Centre network and a useful 'build your van' removable fold out sheet.

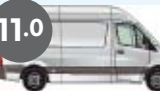

Introduction.

Panel van quick reference guide.

Model and price guide*	Volume m ³	Payload range kg
Caddy van £10,950.00 – £13,670.00		720 to 724
Caddy Maxi van £13,150.00 – £14,950.00		794 to 800
Transporter short wheelbase with low roof £14,480.00 – £17,450.00		802 to 1,383
Transporter short wheelbase with optional medium roof £14,880.00 – £17,935.00		802 to 1,383
Transporter long wheelbase with low roof £15,660.00 – £17,930.00		996 to 1,351
Crafter short wheelbase with low roof £17,250.00 – £18,450.00		1,011
Transporter long wheelbase with optional medium roof £16,060.00 – £18,415.00		996 to 1,351
Crafter medium wheelbase with optional low roof £21,250.00 – £28,610.00		Please note: Roof options alter payload, please ask your Volkswagen Van Centre.
Transporter long wheelbase with optional high roof £16,350.00 – £18,830.00		996 to 1,351
Crafter medium wheelbase with high roof £22,050.00 – £29,410.00		1,387 to 2,603
Crafter medium wheelbase with optional extra high roof £23,190.00 – £30,815.00		Please note: Roof options alter payload, please ask your Volkswagen Van Centre.
Crafter long wheelbase with high roof £22,600.00 – £30,010.00		1,254 to 2,436
Crafter long wheelbase with optional extra high roof £23,740.00 – £31,415.00		Please note: Roof options alter payload, please ask your Volkswagen Van Centre.
Crafter long wheelbase maxi** with high roof £24,050.00 – £30,510.00		1,202 to 2,392
Crafter long wheelbase maxi** with optional extra high roof £25,190.00 – £31,915.00		Please note: Roof options alter payload, please ask your Volkswagen Van Centre.



* Prices exclude VAT, OTR package and optional equipment other than roof packs where applicable.

** Maxi = extended rear overhang.



Introduction.

Main image shows vehicles fitted with optional fog lights.



So you're thinking about a new van. What does it need to carry? How heavy is the load you will put in it? How important is fuel consumption? What about servicing, warranties, available accessories and, of course, finance options?

All these, and many other questions, need to be answered before you can make an informed decision. One that's right for your business.

And because the Volkswagen Commercial Vehicles panel van range gives you such a wide choice, you're sure to get exactly what you need.

This brochure aims to make that process as easy as possible. We suggest you keep the 'Quick reference guide' and 'Build your van' pages open as you browse to help you in your choice.

So let's go to work...

The Volkswagen panel van range.

What a range this is! For starters, we're the only manufacturer with an automatic gearbox on a diesel engine available across the whole of the range. Not only that, but we have a whole host of engine options, seating options, equipment options and so on. But which one is the right vehicle to choose from such a wide range? After all we have everything from the compact Caddy to the enormous Crafter extra high roof, long wheelbase maxi model – all with different payloads and volumes.

The range now includes the Caddy Maxi panel van which sits neatly into the spread of carrying capabilities of the Volkswagen panel van range.

Dependability is built into the very fabric of the Volkswagen Commercial Vehicles' offering. So is quality. So you don't have to worry about it – you can be absolutely certain that whichever model you finally choose, it'll do the job, day in, day out.

So here are a few of the benefits that come as standard:

- UK-wide Van Centre network support
- Finance options tailored to suit your business
- Payloads from 720kg all the way up to 2,603kg
- Load volumes from 3.2m³ to 17.0m³
- Value-for-money parts
- LongLife servicing
- Free 3-year Volkswagen Roadside Assistance
- Wide range of accessories for all models
- High residual values*.

* According to industry influencers.





Safety is a priority.

Your safety is such a vital factor that it is built-in, both with the integral construction of the vehicles, and in the features we include to protect the occupants. A long list of safety and security features applies to every vehicle, but may vary according to model specifications.

Features such as the 4MOTION® all wheel drive system to maintain traction in poor driving conditions, front and rear parking sensors, and anti-theft protection for added security, all offer particular assistance and protection when you're out on the road. Passive safety features include a driver's airbag, which is standard across the range with the option of passenger, side and curtain airbags.

These are some of the safety features available, but please refer to particular model specifications for which feature is available on which model:

- ABS*
- TCS*
- EBC*
- EBD*
- Driver and passenger airbags
- Side and curtain airbags
- Third brake light
- Bulkhead as standard on Caddy, Caddy Maxi and Crafter
- Automatic hazard lights activation under emergency braking standard on Crafter.

Add to all these independent suspension, stable road holding and responsive engines and you can be sure that you'll be as safe as we can make you. The rest is up to you!

* Please refer to the glossary on page 69 of this brochure.

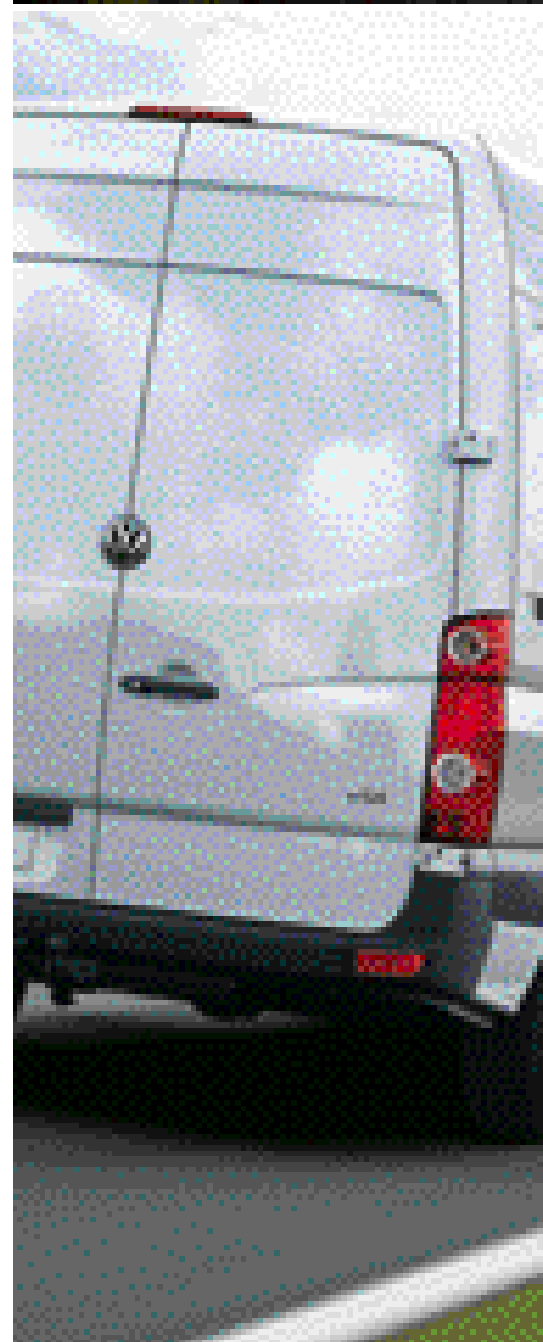







So which model is for me?

You probably already know roughly what you'll need to carry. What is the biggest thing you'll need to get in your vehicle, or the heaviest, or the longest or just the most awkward? If you're a fleet manager, then you'll probably need a variety of options!

Having this in mind should help you get quickly to either the Volkswagen Caddy and Caddy Maxi, Transporter or Crafter ranges as a starting point. Remember though that there is some cross-over between the ranges, and for example, the smallest Crafter may be more suitable than the biggest Transporter, or a Transporter may be more suitable than the Caddy Maxi. The 'Quick Reference Guide' on page 5 will come in handy, so will the fold-out 'Build your van' page at the back of this brochure.

Remember, this brochure only covers panel vans, together with their factory-fitted options. There are separate brochures available for our chassis and double cab, and passenger-carrier ranges. There is also an accessories brochure for you to further enhance your van.



Now let's take a more detailed look at each model in the panel van range so you can begin to make your choice...



Summary of the Volkswagen panel van range.













Model	Gross vehicle weight kg	Wheelbase mm	Panel van low roof		
-------	-------------------------	--------------	--------------------	--	--















Caddy and Caddy Maxi.

Caddy	up to 2,240*	2,682			
Caddy Maxi	up to 2,350*	3,002			

Model	Gross vehicle weight kg	Wheelbase mm	Panel van low roof	Panel van medium roof	Panel van high roof
-------	-------------------------	--------------	--------------------	-----------------------	---------------------

Transporter.

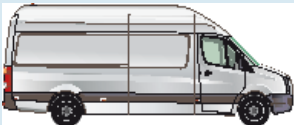
T26	2,600	3,000			
T28	2,800	3,000			
T30	3,000	3,000			
		3,400			
T32	3,200	3,000			
		3,400			

Model	Gross vehicle weight kg	Wheelbase mm	Panel van low roof	Panel van high roof	Panel van extra high roof
Crafter.					
CR30	3,000	3,250			
CR35	3,500	3,665			
		4,325			
		4,325 maxi†			
CR50	5,000	3,665			
		4,325			
		4,325 maxi†			

* Depending on engine and gearbox fitted.

† Maxi = extended rear overhang.

□ Indicates models fitted with optional equipment.

The Volkswagen Caddy and Caddy Maxi.



Load floor showing accommodation of euro-pallet.

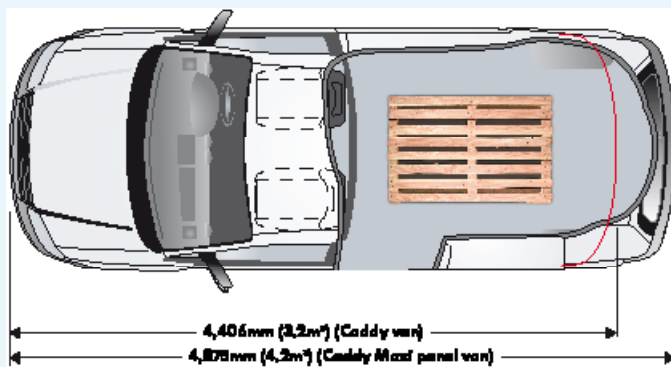

Although the Caddy van is the most compact van in the panel van range, it's a very versatile vehicle, and will carry loads up to 724kg with a generous load space of 3.2m³.

Now joined by its larger sibling, the Caddy Maxi panel van, which has been designed to carry larger payloads extending the carrying capacity to 800kg but more importantly affording greater load space up to a whopping 4.2m³.

And with a choice of powerful and economical 'Pumpe Duese' (PD) diesel engines across both models, there's plenty of scope for all sorts of businesses to maximise their potential.

Getting your load in and out couldn't be easier as both Caddy models have asymmetric twin rear doors and a wide sliding side door. The Caddy Maxi benefits from a second sliding door as standard and is available as an option on the Caddy van.

Apart from the standard safety features such as built-in bulkhead protection and 6 load-lashing rings to save your load shifting about, both Caddy variants are great to drive! There's a host of features (including a CD player as standard) that are too many to mention here.



A full list of all these features can be found on the following pages, but this is an overview of what the Caddy and Caddy Maxi have to offer:

- Load volume up to 4.2m³
- Payload up to 800kg
- Asymmetric rear doors
- 700mm wide sliding side door
- Full height bulkhead
- Choice of up to three diesel engines
- ABS*, EBC*, EBD* and TCS*.

Vehicle weights and dimensions are shown on page 24 and 25. Other features and specifications are detailed on pages 18 and 19.

* Please refer to the glossary on page 69 of this brochure.

Image 02 shows load area of Caddy van with optional second side sliding door.



Volkswagen Caddy and Caddy Maxi standard specifications.

Body.

- 60 litre lockable fuel tank
- Black wheel centre caps
- Externally adjustable exterior mirrors:
 - Convex on passenger's side
 - Aspherical on driver's side
- Front and rear towing eyes
- Grey bumpers
- Heat reflective glass
- Jack and tool kit with steel spare wheel
- Partially galvanised all-steel body
- Roof load rack preparation

Interior.

- Cab area:**
- 2 folding and pivoting sun visors
 - Driver's seat with height, reach and rake adjustment
 - Grab handles on roof frame
 - 'Inca' fabric seat covers
 - Interior light in headliner
 - Passenger seat with reach and rake adjustment
- Rear:**
- 2 door-activated interior lights
 - Half-height load side lining in painted hardboard
 - Interior roof trim in hardboard
 - Load sill protection
 - Sheet steel flooring
- Storage:**
- 2 storage trays in dash panel
 - 4 drinks holders and storage compartment in centre console
 - Open glove compartment
 - Overhead storage

Functional.

- 12V socket
- Digital clock
- Dimmable dashboard illumination
- Manually controlled heating system with dust and pollen filter and air recirculation
- Radio/single CD player, MP3 compatible with 2 wideband speakers
- Remote central locking with deadlocks, internal locking switch and 1 remote key
- Rev counter
- Warning buzzer for lights left on
- Windscreen wiper with variable intermittent delay and wash/wiper system

Technical.

- Front and rear axle:
 - Anti-roll bars, front and rear
 - Front McPherson strut suspension
 - Rear rigid axle with single layer leaf springs
 - Telescopic shock absorbers
- Hydraulic brake system with disc brakes and ABS: Anti-lock Braking System
- Hydraulic power steering
- Steel wheels:
 - 6.0J x 15 (on 69PS* and 104PS engines)
 - 6.0J x 16 (on 140PS engine)
- Tyres:
 - 195/65 R15 (on 69PS* and 104PS engines)
 - 205/55 R16 (on 140PS engine)



Caddy Maxi full height bulkhead.



Radio/CD player.



Overhead storage.

Safety and security.

- 3rd brake light
- ABS: Anti-lock Braking System
- Breaksafe steering wheel lock
- Driver's airbag
- EBC: Engine Braking Control
- EBD: Electronic Brakeforce Distribution
- Electronic immobiliser 'Transponder'
- Halogen main headlights with range control
- Height adjustable head restraints
- Height and rake adjustable safety steering column
- Load lashing rings (6)
- Rear fog lights
- Rear-view mirror with anti-dazzle function
- TCS: Traction Control System
- Three-point, height adjustable and tensioning inertia reel seat belts

Model specific features.

Caddy.

- Glazed asymmetric rear-wing doors
- Full height bulkhead - solid lower and plastic mesh upper
- Heated rear window with rear wash/wipe on larger rear door
- Side sliding door on left

Caddy Maxi.

- Glazed (opaque glass) asymmetric rear-wing doors
- Full height bulkhead - solid
- Side sliding door on left and right

* 69PS engine not available on Caddy Maxi models.



Caddy rear wing doors.



Load lashing rings.



Side sliding door. Image shows Caddy full height bulkhead.

**The Caddy Maxi van.
Always ready to deliver.**



Volkswagen Caddy and Caddy Maxi recommended retail prices.

Model	Manufacturer's RRP					Ins. group**		
	Basic retail excluding VAT £ †	VAT £ †	Total retail including VAT £ †	Total retail including OTR*				
				excluding VAT £ †	including VAT £ †			
Caddy van.								
C20	69PS SDI PD	2.0 l 2KAA32	10,950.00	1,642.50	12,592.50	11,760.00	13,488.00	3E-T2
	104PS TDI PD	1.9 l 2KAA42	11,870.00	1,780.50	13,650.50	12,680.00	14,546.00	3E-T2
	104PS TDI PD DSG	1.9 l 2KAA43	12,870.00	1,930.50	14,800.50	13,680.00	15,696.00	3E-T2
	140PS TDI PD	2.0 l 2KAA64	13,670.00	2,050.50	15,720.50	14,480.00	16,616.00	4A-T2
Caddy Maxi panel van.								
C20	104PS TDI PD	1.9 l 2KHA42	13,150.00	1,972.50	15,122.50	13,960.00	16,018.00	4A-T2
	104PS TDI PD DSG	1.9 l 2KHA43	14,550.00	2,182.50	16,732.50	15,360.00	17,628.00	4A-T2
	140PS TDI PD	2.0 l 2KHA64	14,950.00	2,242.50	17,192.50	15,760.00	18,088.00	4A-T2

*OTR (on the road) package includes the following:

Delivery to retailer	£550.00
Number plates	£20.00
VAT	£85.50
Road fund licence	£185.00
First registration fee	£55.00
Total	£895.50

† Calculated at 15% on all products.

** Insurance group: As advised by the Association of British Insurers (ABI). Please see www.abi.org.uk/carinsurance for more information.



Driver's airbag.



Third brake light.



Load side lining.

Volkswagen Caddy and Caddy Maxi factory options.

	Caddy van	Caddy Maxi panel van	Manufacturer's RRP		
			Basic retail excluding VAT £ †	VAT £ †	Total retail including VAT £ †
Paint options.					
Metallic and pearl paint	•	•	305.00	45.75	350.75
Black paint - 9000	•	•	265.00	39.75	304.75
Danish blue paint - 9506	•	•	100.00	15.00	115.00
Friesen green paint - 9644	•	•	100.00	15.00	115.00
Factory fitted options.					
Alloy wheels - 15", 4 with steel spare (not 140PS)	•	•	375.00	56.25	431.25
Alloy wheels - 16", 4 with steel spare (140PS only)	•	•	645.00	96.75	741.75
Appearance pack - body coloured bumpers and wing mirrors (only with electric pack) ¹	•	•	190.00	28.50	218.50
AUX-IN socket - for connection to external multimedia source	•	•	25.00	3.75	28.75
Cruise control	•	•	175.00	26.25	201.25
ESP plus ²	•	•	250.00	37.50	287.50
Fog lights - front (included in visibility pack A)	•	•	105.00	15.75	120.75
Key - 2nd, for remote locking (included with alarm packs A and B)	•	•	10.00	1.50	11.50
Ladder flap - in roof (only with side door pack A, not with rear door pack B)	•	-	200.00	30.00	230.00
Load floor cover - rubber	•	•	80.00	12.00	92.00
Parking sensors - rear	•	•	220.00	33.00	253.00
Satellite navigation A - colour touch screen (CD), includes trip computer ³	•	•	795.00	119.25	914.25
Steering wheel - leather trimmed, multi-function with trip computer	•	•	280.00	42.00	322.00
Towbar - fixed ball with 13 pin socket ⁴	•	•	315.00	47.25	362.25
Trip computer (included with satellite navigation and steering wheel - leather)	•	•	115.00	17.25	132.25
Tyres - all weather	•	•	105.00	15.75	120.75
Options packs.					
Alarm pack A - perimeter with back-up horn (includes 2nd key for remote locking)	•	•	135.00	20.25	155.25
Alarm pack B - with interior (cab only) and tow away protection (includes 2nd key for remote locking)	•	•	165.00	24.75	189.75
Cab comfort pack ⁵	•	•	225.00	33.75	258.75
Electric pack - electric windows and electrically heated and adjustable mirrors	•	•	270.00	40.50	310.50
Smoking pack - ashtray and cigarette lighter	•	•	15.00	2.25	17.25
Visibility pack A - front fog lights, headlight washers, heated washer jets and washer fluid level indicator	•	•	275.00	41.25	316.25
Visibility pack B - rain sensor, automatic dimming rear view mirror and 'coming home' function	•	•	100.00	15.00	115.00



15" alloy wheels.



Fog lights.



Rubber floor covering.

	Caddy van	Caddy Maxi panel van	Manufacturer's RRP		
			Basic retail excluding VAT £ †	VAT £ †	Total retail including VAT £ †
Airbag packs.					
Airbag pack A - front passenger with deactivation	•	•	180.00	27.00	207.00
Airbag pack B - front passenger with deactivation and side airbags	•	•	335.00	50.25	385.25
Airbag pack D - front passenger with deactivation and thorax head airbags	•	•	470.00	70.50	540.50
Bulkhead packs.					
Bulkhead pack A - deleted	•	-	0.00	0.00	0.00
Door packs.					
Rear door pack A - wing doors with opaque glass, without heated rear window and wash/wipe	•	-	0.00	0.00	0.00
Rear door pack B - tailgate with heated rear window and wash/wipe (not with ladder flap)	•	-	0.00	0.00	0.00
Rear door pack B - tailgate with unheated rear window, without wash/wipe	-	•	0.00	0.00	0.00
Side door pack A - left and right	•	-	240.00	36.00	276.00
Heating and ventilation.					
Air conditioning - 'Climatic', semi-automatic	•	•	755.00	113.25	868.25
Seat packs.					
Seats - leatherette upholstery	•	•	20.00	3.00	23.00
Seats - 'Robust' upholstery	•	•	35.00	5.25	40.25
Seat pack A - heated driver and front passenger seats	•	•	195.00	29.25	224.25

- Options.
- Not available.

† Calculated at 15% on all products.

¹ **Appearance pack:** Restricted colours, please confirm availability with your Volkswagen Van Centre.

² **ESP plus:** Includes Driver Steering Response (DSR) and trailer stabilisation function.

³ **Satellite navigation:** Replaces radio, includes RDS radio function with single CD (audio CDs cannot be played when using navigation function).

⁴ **Towbars:** An adaptor is available from Van Centres, to allow connection to twin 7 pin sockets.

⁵ **Cab comfort pack:** Cab carpet, height adjustable front seats, storage under front seats, vanity mirrors and dash tray with cover.



Ladder flap for Caddy van.



'Climatic' air conditioning.



Towbar.

Caddy van dimensions and weights.

Caddy van.

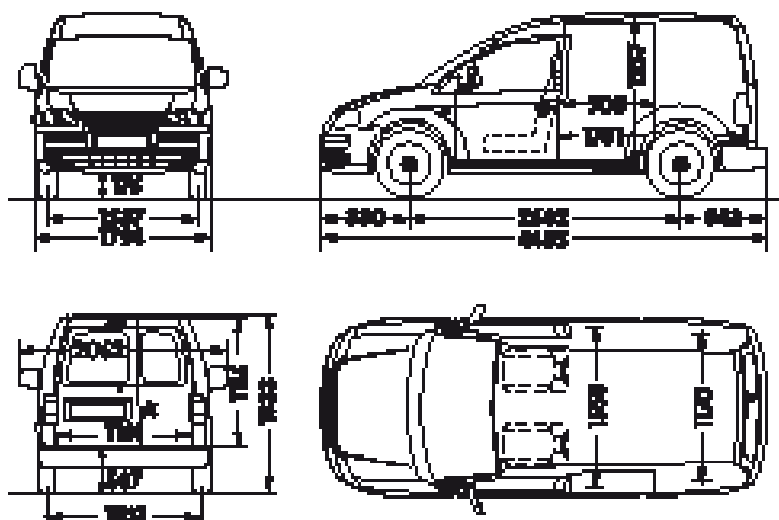

Wheelbase		2,682
Load compartment	length ¹	1,781
	width	1,558
	height	1,257
Lateral sliding door	width	700
	height	1,108
Rear wing doors	width	1,181
	height	1,116
Turning circle (wall to wall)		11.1m

¹ With bulkhead (half-height, with plastic mesh upper).

Dimensions in mm unless otherwise indicated.

Model	Gross vehicle weight kg	Engine		Axle load limit front / rear kg	Trailer weight braked / unbraked ² kg	Gross train weight kg	Unladen weight kg	Payload kg
C20	2,185	69PS SDI PD	2.0l	1,050 / 1,230	1,325 / 720	3,500	1,465	720
	2,211	104PS TDI PD	1.9l	1,065 / 1,230	1,425 / 740	3,500	1,491	724
	2,240	104PS TDI PD DSG	1.9l	1,090 / 1,230	1,425 / 750	3,500	1,520	720
	2,222	140PS TDI PD	2.0l	1,075 / 1,230	1,500 / 740	3,500	1,471	751

Caddy van fuel consumption and performance.

Engine		Urban ³ mpg (l/100km)	Extra urban ³ mpg (l/100km)	Combined ³ mpg (l/100km)	Acceleration 0-62 mph	Top speed (where the law permits) mph
Caddy van.						
69PS SDI PD	2.0l	38.2 (7.4)	54.3 (5.2)	47.1 (6.0)	20.1	88
104PS TDI PD	1.9l	38.7 (7.3)	53.3 (5.3)	47.1 (6.0)	13.0	103
104PS TDI PD DSG	1.9l	34.4 (8.2)	49.6 (5.7)	42.8 (6.6)	13.0	103
140PS TDI PD	2.0l	36.7 (7.7)	52.3 (5.4)	45.6 (6.2)	10.1	116

Caddy Maxi van dimensions and weights.

Caddy Maxi panel van.

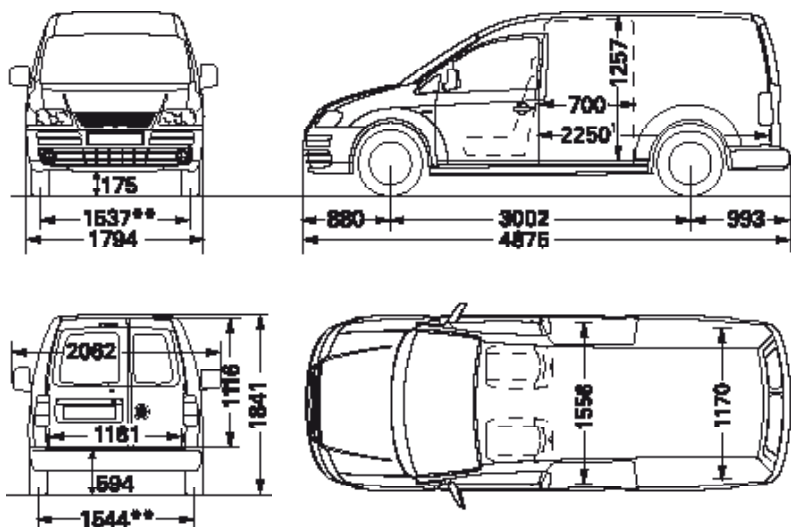

Wheelbase		3,002
Load compartment	length ¹	2,250
	width	1,558
	height	1,257
Lateral sliding door	width	4.2m ³
	height	700
Rear wing doors	width	1,108
	height	1,181
Turning circle (wall to wall)	width	1,116
	height	12.2m

¹ With solid bulkhead.
^{**} -6mm, depending on wheel size.
 Dimensions in mm unless otherwise indicated.

The height measurements listed here can differ by approx. ± 50mm depending on equipment.

Model	Gross vehicle weight kg	Engine	Axle load limit front / rear kg	Trailer weight braked / unbraked ² kg	Gross train weight kg	Unladen weight kg	Payload kg	
C20	2,315	104PS TDI PD	1.9l	1,110 / 1,300	1,500 / 750	3,500	1,515	800
	2,350	104PS TDI PD DSG	1.9l	1,170 / 1,300	1,500 / 750	3,500	1,556	794
	2,342	140PS TDI PD	2.0l	1,165 / 1,300	1,500 / 750	3,500	1,542	800

The payload includes the driver at 75kg. Actual weights may vary by model specification.

Roof load limit: 100kg.

Trailer nose weight limit: 80kg.

² For 12% gradient.

Weights are for vehicles with standard specification. The addition of factory options or Volkswagen Van Centre fitted accessories may affect unladen weight and payload.

Caddy Maxi van fuel consumption and performance.

Engine	Urban ³ mpg (l/100km)	Extra urban ³ mpg (l/100km)	Combined ³ mpg (l/100km)	Acceleration 0-62 mph	Top speed (where the law permits) mph	
Caddy Maxi van.						
104PS TDI PD	1.9l	38.2 (7.4)	54.3 (5.2)	47.1 (6.0)	13.3	102
104PS TDI PD DSG	1.9l	34.4 (8.2)	47.9 (5.9)	41.5 (6.8)	13.3	103
140PS TDI PD	2.0l	36.7 (7.7)	52.3 (5.4)	45.6 (6.2)	10.5	116

³ With 50% payload.

The performance figures listed above apply to vehicles with 5-speed or 6-speed manual gearbox and DSG semi-automatic gearbox, without optional extras.

The Caddy van.
A skilled performer.



Caddy and Caddy Maxi engine specifications.

	69PS SDI PD ¹	104PS TDI PD	140PS TDI PD
Engine type	Transverse, water cooled in line	Transverse, water cooled in line, variable geometry turbocharger with intercooler	
Mixture preparation/injection method	Unit injector pump direct injection		
Exhaust emission standard	EU 4		
No. of cylinders	4		
Cubic capacity, cm ³	1,968	1,896	1,968
Output, PS at rpm	69 at 4,200	104 at 4,000	140 at 4,000
Torque, max. Nm/rpm	140/2,200	250/1,900	320/1,800 – 2,500
Diesel Particulate Filter (DPF)	-	²	•
5-speed manual gearbox	•	•	-
6-speed manual gearbox	-	-	•
6-speed semi-automatic	-	-	-
DSG gearbox	-	•	-
Front wheel drive	•	•	•

Electrics.

Alternator (all variants)	110A
Battery	61Ah (330A)

• Available

- Not available

¹ 69PS TDI PD diesel engine is not available for the Caddy Maxi

² The 104PS TDI PD diesel engine with 6-speed DSG semi-automatic gearbox is equipped with a Diesel Particulate Filter (DPF) as standard on Caddy Maxi

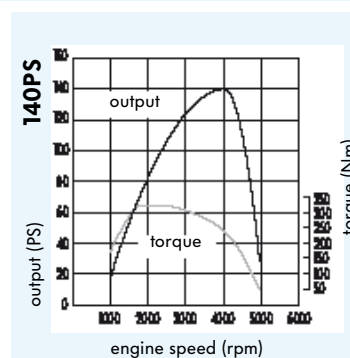
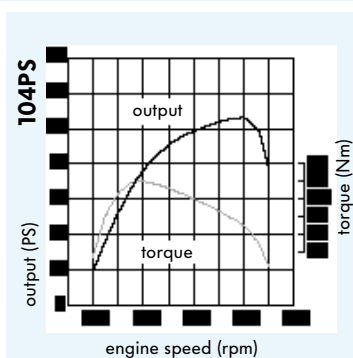
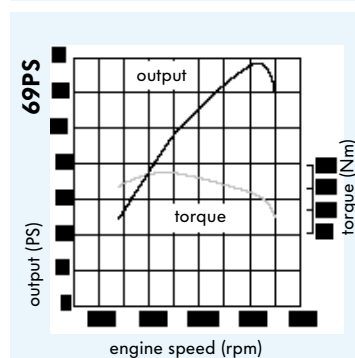

Direct Shift Gearbox.

The award winning and highly acclaimed Direct Shift Gearbox (DSG) is unique to the commercial vehicle market and operates with two automatic clutches – while one is engaged, the other is ready and to accept the next gear. This twin clutch technology means you can change gear much faster than with a standard automatic gearbox – actually in less than four hundredths of a second.

This means that for stop-start round city work the DSG comes into its own, making life much easier for the driver. Of course you can still change gear manually if you prefer!



Caddy and Caddy Maxi Sportline.
Stand out from the crowd.



2.0 TDI
SPORTLINE





The Sportline range has just got bigger with the arrival of the new Caddy and Caddy Maxi Sportline. Designed to work hard and play hard these vans are definitely for the adventure seeker in you. These exciting models complement your lifestyle. As individual as you and with performance to match from the powerful 140PS diesel engine.

For more information, a Sportline brochure is available from your nearest Volkswagen Van Centre.

www.volkswagen-vans.co.uk/sportline

The Volkswagen Transporter.

Load floor showing accommodation of euro-pallets.

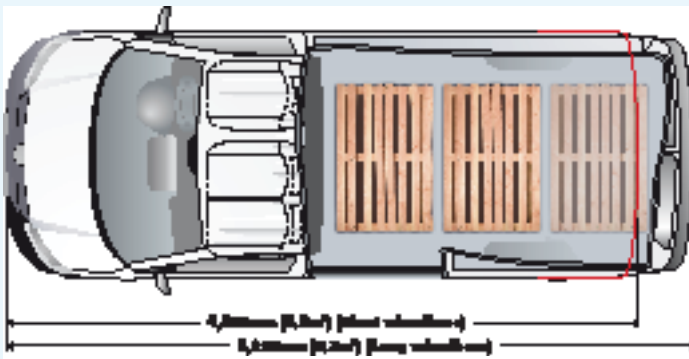

The world-renowned Transporter has grown a solid reputation from year to year, winning many awards along the way. Packed full of innovative ideas, the latest Transporter is even better equipped than any of its predecessors. And that's not surprising. You'd be hard pushed to fault this vehicle - its versatility, features, specification and overall good looks make it a winner for all kinds of businesses, and for all kinds of reasons.

As an example of the outstanding technology that has been invested in this range, there are four innovative and extremely economical TDI 'Pumpe Duese' (PD) diesel engines. These provide outstanding load-pulling capability, great fuel economy, and make the Transporter an absolute pleasure to drive.



Main features of the Transporter range include:

- Load volumes from 5.8m³ to 9.3m³
- Payloads from 802kg up to 1,383kg
- 4 TDI PD diesel engines from 84PS to 174PS
- Short or long wheelbase
- Low, medium or high roof
- Solid twin rear doors as standard or optional tailgate
- Left side sliding door as standard
- Dual passenger seat with folding backrest provides additional load length.

More detailed specifications and options can be found on the following pages.



Transporter panel van standard specifications.

Body.

- 80 litre lockable fuel tank
- Black wheel centre caps
- Externally adjustable exterior mirrors:
 - Convex on passenger's side
 - Spherical on driver's side
- Front and rear towing eyes
- Galvanised full steel body
- Grey bumpers
- Heat reflective glass
- Jack and tool kit (heavy duty on T32 models) with steel spare wheel
- Unglazed rear wing doors

Interior.

Cab area:

- 2 folding and pivoted sun visors
- Dash mounted gear lever
- Driver's seat with height, lumbar, reach and rake adjustment
- Dual passenger seat with storage box and folding seat backrest (fixed backrest with optional bulkheads)
- 'Inca' fabric seat covers
- Interior light
- Rubber floor covering

Storage:

- 2 storage compartments in dash panel
- 2 storage compartments in driver's door
- 2 storage compartments in passenger door
- Drinks holder
- Lockable glove compartment
- Open storage compartment in dash panel including mobile phone holder
- Overhead storage
- Storage net on lower dash passenger side

Rear:

- 2 door-activated interior lights (3 with optional high roof)
- Half height load side lining in hardboard
- Interior entry step
- Interior roof trim in painted hardboard (low roof only)
- Load lashing rings (SWB: 6, LWB: 8)
- Rear door interior release lever
- Sheet steel flooring
- Side sliding door on left

Functional.

- 12V socket
- Digital clock
- Manually controlled heating system with dust and pollen filter and air recirculation
- Radio/single CD player (2 DIN) with 2 speakers
- Remote central locking with deadlocks (1 fixed and 1 folding remote key)
- Rev counter
- Warning buzzer for lights left on
- Windscreen wiper with variable intermittent delay and wash/wiper system



Radio/CD player.



Rear wing doors.



Dash mounted gear lever.

Technical.

- Front and rear axle:
 - Anti-roll bars, front and rear (T26 front only)
 - Front McPherson strut suspension
 - Independent suspension
 - Rear miniblock springs
 - Telescopic shock absorbers
- Hydraulic brake system with ventilated disc brakes
- Power steering
- Rear differential lock (4MOTION® only)
- Steel wheels: 6.5J x 16
- Tyres: 205/65 R16 (on 84 and 102PS versions)
215/65 R16 (on 130 and 174PS versions)

Safety and security.

- 3rd brake light
- ABS: Anti-lock Braking System
- Breaksafe steering wheel lock
- Driver and passenger airbags
- EBC: Engine Braking Control (not 4MOTION®)
- EBD: Electronic Brakeforce Distribution
- Electronic immobiliser 'Transponder'
- Halogen main headlights with range control
- Height adjustable head restraints
- Height adjustable, tensioning seat belts for all outer cab seats
- Height and rake adjustable safety steering column
- Rear fog light
- TCS: Traction Control System (not 4MOTION®)
- Three-point inertia reel seat belts for all seats



Storage in driver and front passenger doors.



Side sliding door.



Driver and passenger airbags.

The Transporter window van with optional kombi pack.



See the passenger carriers brochure for more information about optional kombi packs.

The Transporter window van with optional kombi pack is the dual-purpose passenger/load carrying combination. If you need to carry up to 5 passengers and take loads of other equipment with you in the back, then this option is for you. This way you can delete the rear side windows to conceal the load, and add a second row of seats to take additional passengers. Just specify a kombi pack on the T32 Transporter window van.

For further information about this highly versatile vehicle see the **passenger carriers brochure**, which can be found on our website www.volkswagen-vans.co.uk or by picking one up at your nearest Volkswagen Van Centre.

Main features include:

- Carries up to 5 passengers (plus driver) plus your load
- Short or long wheelbase
- Tailgate as standard, rear doors optional
- Heated rear window
- Left side sliding door with windows
- 3 TDI PD diesel engines from 102PS to 174PS
- Low, medium or high roof
- ABS and driver and passenger airbags.

Optional kombi pack A.



Comprises of a 1st rear row of seats with single seat left and dual seat right, sliding windows in side door and opposite, without rear side windows.

Optional kombi pack B.



Comprises of a 1st rear row 3-seat bench seat, sliding windows in side door and opposite, without rear side windows.

Transporter panel van recommended retail prices.

Model	Manufacturer's RRP						Ins. group**	
	Basic retail excluding VAT £ †	VAT £ †	Total retail including VAT £ †	Total retail including OTR*				
				excluding VAT £ †	including VAT £ †			
Panel van short wheelbase.								
T26	84PS TDI PD	7HAA62	14,480.00	2,172.00	16,652.00	15,290.00	17,547.50	5E-T2
T28	84PS TDI PD	7HAB62	14,830.00	2,224.50	17,054.50	15,640.00	17,950.00	6E-T2
	102PS TDI PD	7HAB72	15,550.00	2,332.50	17,882.50	16,360.00	18,778.00	6E-T2
	130PS TDI PD	7HAB01	16,750.00	2,512.50	19,262.50	17,560.00	20,158.00	6E-T2
	174PS TDI PD	7HAB11	18,230.00	2,734.50	20,964.50	19,040.00	21,860.00	6E-T2
T30	84PS TDI PD	7HAC62	15,180.00	2,277.00	17,457.00	15,990.00	18,352.50	6E-T2
	102PS TDI PD	7HAC72	15,900.00	2,385.00	18,285.00	16,710.00	19,180.50	6E-T2
	130PS TDI PD	7HAC01	17,100.00	2,565.00	19,665.00	17,910.00	20,560.50	6E-T2
	130PS TDI PD Tiptronic	7HAC03	18,100.00	2,715.00	20,815.00	18,910.00	21,710.50	6E-T2
	130PS TDI PD 4MOTION®	7HAC05	19,300.00	2,895.00	22,195.00	20,110.00	23,090.50	6E-T2
	174PS TDI PD	7HAC11	18,580.00	2,787.00	21,367.00	19,390.00	22,262.50	6E-T2
T32	102PS TDI PD	7HAD72	16,250.00	2,437.50	18,687.50	17,060.00	19,583.00	6E-T2
	130PS TDI PD	7HAD01	17,450.00	2,617.50	20,067.50	18,260.00	20,963.00	7E-T2
Panel van long wheelbase.								
T30	84PS TDI PD	7HHC62	15,660.00	2,349.00	18,009.00	16,470.00	18,904.50	6E-T2
	102PS TDI PD	7HHC72	16,380.00	2,457.00	18,837.00	17,190.00	19,732.50	6E-T2
	130PS TDI PD	7HHC01	17,580.00	2,637.00	20,217.00	18,390.00	21,112.50	6E-T2
	130PS TDI PD Tiptronic	7HHC03	18,580.00	2,787.00	21,367.00	19,390.00	22,262.50	6E-T2
	130PS TDI PD 4MOTION®	7HHC05	19,780.00	2,967.00	22,747.00	20,590.00	23,642.50	6E-T2
	174PS TDI PD	7HHC11	19,060.00	2,859.00	21,919.00	19,870.00	22,814.50	6E-T2
T32	102PS TDI PD	7HHD72	16,730.00	2,509.50	19,239.50	17,540.00	20,135.00	7E-T2
	130PS TDI PD	7HHD01	17,930.00	2,689.50	20,619.50	18,740.00	21,515.00	7E-T2

***OTR (on the road) package for panel vans includes the following:**

Delivery to retailer	£550.00
Number plates	£20.00
VAT	£85.50
Road fund licence	£185.00
First registration fee	£55.00
Total	£895.50

† Calculated at 15% on all products.

** Insurance group: As advised by the Association of British Insurers (ABI). Please see www.abi.org.uk/carinsurance for more information.

Transporter panel van factory options.

	SWB				LWB		Manufacturer's RRP		
	T26	T28	T30	T32	T30	T32	Basic retail	VAT £ †	Total retail
							excluding		
							VAT £ †	VAT £ †	VAT £ †
Paint options.									
Metallic and pearl paint	•	•	•	•	•	•	475.00	71.25	546.25
Black paint - 9000	•	•	•	•	•	•	275.00	41.25	316.25
Danish blue paint - 9506	•	•	•	•	•	•	100.00	15.00	115.00
Stone blue paint - 9544	•	•	•	•	•	•	100.00	15.00	115.00
Factory fitted options.									
Alloy wheels - 'Cartagena' 16" with 215/65 R16 tyres, 4 with steel spare (84/102PS engines only)	•	•	•	-	•	-	510.00	76.50	586.50
Alloy wheels - 'Cartagena' 16" , 4 with steel spare (130/174PS engines only)	-	•	•	-	•	-	420.00	63.00	483.00
Alloy wheels - 'Miyato' 16" with 215/65 R16 tyres, 4 with steel spare (84/102PS engines only)	•	•	•	-	•	-	445.00	66.75	511.75
Alloy wheels - 'Miyato' 16" , 4 with steel spare (130/174PS engines only)	-	•	•	-	•	-	345.00	51.75	396.75
Alloy wheels - 'Thunder' 17" with 235/55 R17 tyres, 4 with steel spare (130/174PS engines only, not with tyres - all weather)	-	•	•	-	•	-	910.00	136.50	1,046.50
Battery - second¹	•	•	•	•	•	•	125.00	18.75	143.75
CD changer - six disc	•	•	•	•	•	•	250.00	37.50	287.50
Cruise control	•	•	•	•	•	•	160.00	24.00	184.00
ESP²	•	•	•	•	•	•	295.00	44.25	339.25
Fog lights - front	•	•	•	•	•	•	135.00	20.25	155.25
Load floor cover - rubber, with step light (SWB only)	•	•	•	•	-	-	120.00	18.00	138.00
	-	-	-	-	•	•	135.00	20.25	155.25
Load side lining - full-height hardboard³ (SWB only)	•	•	•	•	-	-	145.00	21.75	166.75
	-	-	-	-	•	•	170.00	25.50	195.50
Mud flaps - front and rear	•	•	•	•	•	•	90.00	13.50	103.50
Parking brake - hill hold control (includes ESP)	•	•	•	•	•	•	335.00	50.25	385.25
Parking sensors - rear	•	•	•	•	•	•	185.00	27.75	212.75
Roof load rack preparation (not with medium or high roof packs)	•	•	•	•	•	•	65.00	9.75	74.75
Smoking pack - ashtray, cigarette lighter and cup holder	•	•	•	•	•	•	15.00	2.25	17.25
Sunroof - glass, electric, front (not with roof ventilation/extraction - rear compartment, medium or high roof packs, bulkhead packs, or side door pack A)	•	•	•	•	•	•	445.00	66.75	511.75
Tachograph - digital, includes console on dash	•	•	•	•	•	•	440.00	66.00	506.00
Towbar - fixed ball with 13 pin socket⁴	•	•	•	•	•	•	340.00	51.00	391.00
Towbar - removable ball with 13 pin socket⁴	•	•	•	•	•	•	425.00	63.75	488.75
Trip computer (included with satellite navigation)	•	•	•	•	•	•	105.00	15.75	120.75
Tyres - all weather, 215/65 R16 (84/102PS engines only)	•	•	•	•	•	•	185.00	27.75	212.75
Tyres - all weather (130/174PS engines only, not with alloy wheels - 'Thunder' 17")	-	•	•	•	•	•	85.00	12.75	97.75



16" 'Miyato' alloy wheel.



17" 'Thunder' alloy wheel.



Cruise control.

	SWB				LWB		Manufacturer's RRP		
	T26	T28	T30	T32	T30	T32	Basic retail	VAT £ †	Total retail
							excluding		including
							VAT £ †	VAT £ †	
Options packs.									
Alarm pack A - perimeter with back-up horn (includes 2nd remote key) ⁵	•	•	•	•	•	•	125.00	18.75	143.75
Alarm pack B - with interior (cab only) and tow away protection (includes 2nd remote key) (not with medium or high roof packs or roof ventilation/extraction) ⁶	•	•	•	•	•	•	145.00	21.75	166.75
Appearance pack - electric windows, electrically adjustable, heated, folding and body coloured mirrors and body coloured bumpers (not with electric pack B or C or 'S'/'SE' pack)	•	•	•	•	•	•	610.00	91.50	701.50
Cab comfort pack⁷	•	•	•	•	•	•	255.00	38.25	293.25
Electric pack B - electric windows, electrically heated and adjustable mirrors and internal central locking control	•	•	•	•	•	•	320.00	48.00	368.00
Electric pack C - electric windows, electrically heated, adjustable and folding mirrors and internal central locking control	•	•	•	•	•	•	395.00	59.25	454.25
S pack - alarm pack A, bulkhead pack A, electric pack B ⁸	•	•	•	•	•	•	500.00	75.00	575.00
SE pack - air conditioning pack A, alarm pack A, bulkhead pack A, electric pack B, seat pack A ⁸	•	•	•	•	•	•	1,070.00	160.50	1,230.50
Satellite navigation A - monochrome screen, includes trip computer ^{5,9}	•	•	•	•	•	•	1,165.00	174.75	1,339.75
Satellite navigation B - colour screen, includes trip computer ^{5,10}	•	•	•	•	•	•	1,770.00	265.50	2,035.50
Visibility pack A - headlamp washers, fluid level indicator and heated washer jets	•	•	•	•	•	•	160.00	24.00	184.00
Visibility pack B - rain sensor and automatic dimming rear view mirror	•	•	•	•	•	•	85.00	12.75	97.75

Airbag packs.

Airbag pack C - side and front curtain airbags (only with seat pack B)	•	•	•	•	•	•	230.00	34.50	264.50
---	---	---	---	---	---	---	--------	-------	--------

- Options.
- Not available.

† Calculated at 15% on all products.

- Battery - second:** 72Ah with dual passenger seat, 80Ah with single passenger seat.
- ESP:** Also includes Active Rollover Protection (ARP), maximum brake support (more braking power for fully loaded vehicles), prefill (to reduce stopping distance/time), fading brake support and improved hydraulic brake assist.
- Load side lining:** Side panels covered to roof, tailgate/rear doors only half-height.
- Towbars:** An adaptor is available from Van Centres, to allow connection to twin 7 pin sockets. Only one front towing eye with towbars.
- Battery uprated to 80Ah on 84/102PS engines, 95Ah on 130/174PS engines.
- Alarm pack B:** Battery uprated to 95Ah.
- Cab comfort pack:** 'Box' fabric seat trim, carpet in cab, storage compartments in outer side of driver and passenger seats, vanity mirrors, sunglasses holder, interior light delay, 2 reading lights, instrument dimmer, grab handles on 'A' pillars, two tone horn and additional noise suppression measures.
- It is not possible to select alternative equipment to that specified.
- Satellite navigation A:** Replaces radio/in-dash CD player, includes RDS radio function with single CD and CD changer control, where fitted (audio CDs cannot be played when using navigation function).
- Satellite navigation B:** Replaces radio/in-dash CD player, includes RDS radio function and CD changer control, where fitted (audio CDs cannot be played).

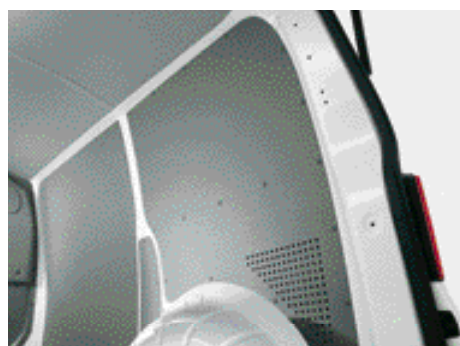

Full-height load side lining.



Roof load rack preparation.



Satellite navigation system.

Transporter panel van factory options. (continued)

	SWB				LWB		Manufacturer's RRP		
	T26	T28	T30	T32	T30	T32	Basic retail excluding VAT £ †	VAT £ †	Total retail including VAT £ †
Bulkhead packs.									
Bulkhead pack A - high, without window, includes 2 additional 'C' pillar load lashing rings (not with 'Duo' upholstery or sunroof) ¹²	•	•	•	•	•	•	155.00	23.25	178.25
Bulkhead pack B - high, with window, includes 2 additional 'C' pillar load lashing rings (not with 'Duo' upholstery or sunroof) ^{11,12}	•	•	•	•	•	•	185.00	27.75	212.75
Bulkhead pack C - high, with sliding window, includes 2 additional 'C' pillar load lashing rings (not with 'Duo' upholstery or sunroof) ^{11,12}	•	•	•	•	•	•	220.00	33.00	253.00
Bulkhead pack E - high, without window, includes 2 additional 'C' pillar load lashing rings and load lashing rails (not with 'Duo' upholstery, load side lining - full-height hardboard or sunroof) ¹²									
(SWB only)	•	•	•	•	-	-	480.00	72.00	552.00
(LWB only)	-	-	-	-	•	•	535.00	80.25	615.25
Bulkhead pack F - high, with window, includes 2 additional 'C' pillar load lashing rings and load lashing rails (not with 'Duo' upholstery, load side lining - full-height hardboard or sunroof) ^{11,12}									
(SWB only)	•	•	•	•	-	-	510.00	76.50	586.50
(LWB only)	-	-	-	-	•	•	565.00	84.75	649.75
Bulkhead pack G - high, with sliding window, includes 2 additional 'C' pillar load lashing rings and load lashing rails (not with 'Duo' upholstery, load side lining - full-height hardboard or sunroof) ^{11,12}									
(SWB only)	•	•	•	•	-	-	545.00	81.75	626.75
(LWB only)	-	-	-	-	•	•	600.00	90.00	690.00
Door packs.									
Rear doors - 250° hinges (not with rear door packs A or B)	-	-	-	-	•	•	240.00	36.00	276.00
Rear door pack A - tailgate with heated rear window and wash/wipe (not with high roof packs) ¹¹	•	•	•	•	•	•	-25.00	-3.75	-28.75
Rear door pack B - tailgate without window (not with high roof packs)	•	•	•	•	•	•	-120.00	-18.00	-138.00
Rear door pack C - wing doors with heated rear windows and wash/wipe (included with roof packs E and F) ¹¹	•	•	•	•	•	•	95.00	14.25	109.25
Side door pack A - right only (no left door), manual (not with sunroof)	•	•	•	•	•	•	0.00	0.00	0.00
Side door pack B - left and right, manual (not with high roof packs)	•	•	•	•	•	•	390.00	58.50	448.50
Heating and ventilation.									
Air conditioning pack A - manual, dash ¹³	•	•	•	•	•	•	640.00	96.00	736.00
Charcoal canister - for ventilation system	•	•	•	•	•	•	15.00	2.25	17.25
Roof ventilation/extraction - rear compartment (not with alarm pack B or sunroof)	•	•	•	•	•	•	275.00	41.25	316.25



Parking sensors.



Bulkhead - full-height.



Air conditioning.

	SWB				LWB		Manufacturer's RRP		
	T26	T28	T30	T32	T30	T32	Basic retail	VAT £ †	Total retail
							excluding		including

Roof packs.

Roof pack A - medium, white (not with alarm pack B, roof load rack preparation or sunroof) ¹⁴	-	•	•	-	•	•	400.00	60.00	460.00
Roof pack B - medium, body-coloured (not with alarm pack B, roof load rack preparation or sunroof) ¹⁴	-	•	•	-	•	•	485.00	72.75	557.75
Roof pack C - high, white, includes high rear wing doors without windows (not with alarm pack B, roof load rack preparation, sunroof or side door pack B) (not with T30 LWB 102PS) ¹⁴	-	-	-	-	•	•	690.00	103.50	793.50
Roof pack D - high, body-coloured, includes high rear wing doors without windows (not with alarm pack B, roof load rack preparation, sunroof or side door pack B) (not with T30 LWB 102PS) ¹⁴	-	-	-	-	•	•	805.00	120.75	925.75
Roof pack E - high, white, includes high rear wing doors with heated rear windows and wash/wipe (not with alarm pack B, roof load rack preparation, sunroof or side door pack B) (not with T30 LWB 102PS) ^{11,14}	-	-	-	-	•	•	785.00	117.75	902.75
Roof pack F - high, body-coloured, includes high rear wing doors with heated rear windows and wash/wipe (not with alarm pack B, roof load rack preparation, sunroof or side door pack B) (not with T30 LWB 102PS) ^{11,14}	-	-	-	-	•	•	900.00	135.00	1,035.00

Seat packs.

Seats - leatherette upholstery	•	•	•	•	•	•	25.00	3.75	28.75
Seats - robust upholstery (only with seat pack B)	•	•	•	•	•	•	80.00	12.00	92.00
Seats - 'Duo' cloth upholstery (only with seat pack B, not with bulkhead packs)	•	•	•	•	•	•	115.00	17.25	132.25
Seat pack A - driver's comfort seat ¹⁵	•	•	•	•	•	•	50.00	7.50	57.50
Seat pack B - driver and single passenger comfort seats ¹⁶	•	•	•	•	•	•	15.00	2.25	17.25
Seat pack F - heated driver's seat ¹³	•	•	•	•	•	•	110.00	16.50	126.50
Seat pack G - heated driver and front passenger seats ¹³	•	•	•	•	•	•	220.00	33.00	253.00

- Options.
- Not available.

† Calculated at 15% on all products.

¹¹ Vehicles with through vision have a rear view mirror with anti-dazzle function.

¹² **Bulkhead packs:** Dual passenger seat has fixed backrest with optional bulkheads.

¹³ **Uprated alternator:** 120A on 84/102PS engines, 150A on 130/174PS engines.

¹⁴ **Roof packs:** Please confirm availability with your Volkswagen Van Centre.

¹⁵ **Comfort seat:** Adds armrest (height adjustment and lumbar support standard for driver's seat).

¹⁶ **Comfort seats:** Add armrests for both front seats, passenger height adjustment and lumbar support (height adjustment and lumbar support standard for driver's seat).



Headlight cleaning system.



Comfort seats for driver and front passenger.



Tailgate.

Transporter panel van dimensions and weights.

Panel van short wheelbase low and medium roof.

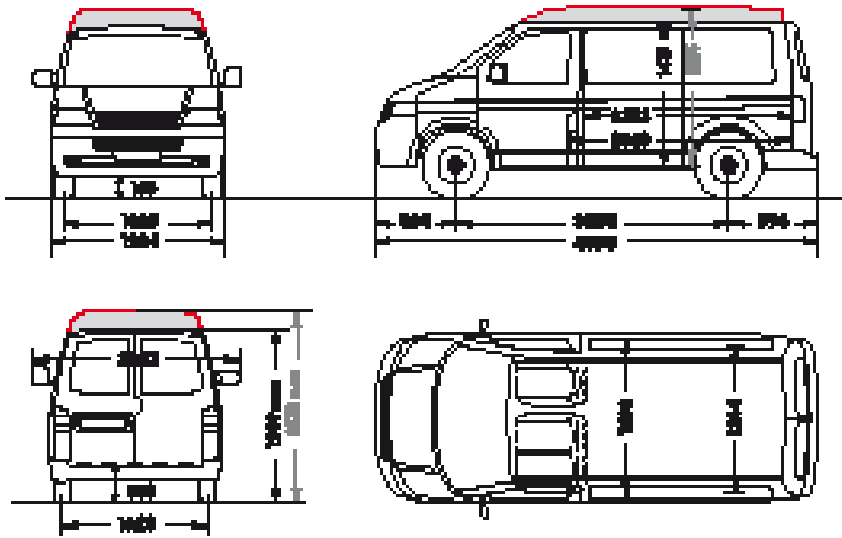

	Roof height	
	low	med
Wheelbase	3,000	3,000
Load compartment	length	2,570
	width	1,692
	height	1,410
	area	4.3m ²
	volume	5.8m ³
Width (between wheel housings)	1,244	1,244
Lateral sliding door	width	1,020
	height	1,284
Rear doors	width	1,485
	height	1,305
Turning circle (wall to wall)	11.9m	11.9m

Dimensions in mm unless otherwise indicated.

□ Indicates optional roof height.

Model	Gross vehicle weight kg	Engine	Axle load limit front / rear kg	Trailer weight braked / unbraked* kg	Gross train weight kg	Unladen weight** kg	Payload*** kg
T26	2,600	84PS TDI PD	1,400 / 1,400	2,200 / 750	4,800	1,798	802
T28	2,800	84PS TDI PD	1,450 / 1,550	2,200 / 750	4,800	1,798	1,002
		102PS TDI PD	1,450 / 1,550	2,200 / 750	4,900	1,798	1,002
		130PS TDI PD	1,575 / 1,550	2,500 / 750	5,200	1,872	928
		174PS TDI PD	1,575 / 1,550	2,500 / 750	5,200	1,872	928
T30	3,000	84PS TDI PD	1,500 / 1,625	2,200 / 750	4,800	1,798	1,202
		102PS TDI PD	1,500 / 1,625	2,200 / 750	4,900	1,798	1,202
		130PS TDI PD	1,575 / 1,625	2,500 / 750	5,200	1,872	1,128
		130PS TDI PD Tiptronic	1,575 / 1,625	2,500 / 750	5,200	1,872	1,128
		130PS TDI PD 4MOTION®	1,575 / 1,625	2,500 / 750	5,300	1,972	1,028
		174PS TDI PD	1,575 / 1,625	2,500 / 750	5,200	1,872	1,128
T32	3,200	102PS TDI PD	1,630 / 1,720	2,200 / 750	5,200	1,817	1,383
		130PS TDI PD	1,650 / 1,720	2,500 / 750	5,200	1,891	1,309

Panel van long wheelbase low, medium and high roof.

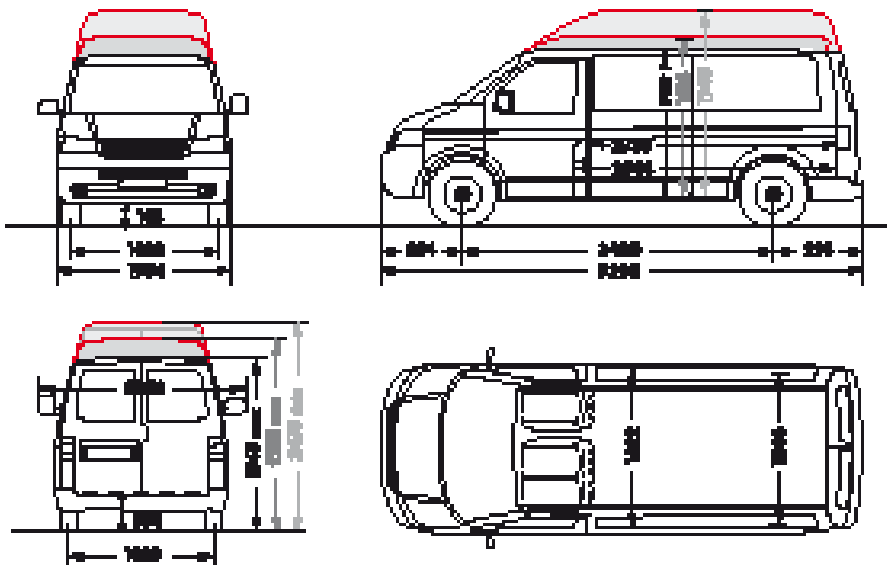

	Roof height		
	low	med	high
Wheelbase	3,400	3,400	3,400
Load compartment	length	2,970	2,970
	width	1,692	1,692
	height	1,410	1,626
	area	5.0m ²	5.0m ²
	volume	6.7m ³	9.3m ³
Width (between wheel housings)	1,244	1,244	1,244
Lateral sliding door	width	1,020	1,020
	height	1,284	1,284
Rear doors	width	1,485	1,485
	height	1,305	1,694
Turning circle (wall to wall)	13.2m	13.2m	13.2m

Dimensions in mm unless otherwise indicated.

□ Indicates optional roof height.

The height measurements listed here may differ by approx ± 50mm depending on equipment fitted. Please note vehicle drawings are not to scale.

Model	Gross vehicle weight kg	Engine	Axle load limit front / rear kg	Trailer weight braked / unbraked* kg	Gross train weight kg	Unladen weight** kg	Payload*** kg
T30	3,000	84PS TDI PD	1,575 / 1,625	2,200 / 750	4,800	1,829	1,171
		102PS TDI PD	1,575 / 1,625	2,200 / 750	4,900	1,829	1,171
		130PS TDI PD	1,575 / 1,625	2,500 / 750	5,200	1,903	1,097
		130PS TDI PD Tiptronic	1,575 / 1,625	2,500 / 750	5,200	1,903	1,097
		130PS TDI PD 4MOTION®	1,575 / 1,625	2,500 / 750	5,300	2,004	996
		174PS TDI PD	1,575 / 1,625	2,500 / 750	5,200	1,903	1,097
T32	3,200	102PS TDI PD	1,650 / 1,720	2,200 / 750	5,200	1,849	1,351
		130PS TDI PD	1,650 / 1,720	2,500 / 750	5,200	1,919	1,281

Trailer nose weight is 100kg.

Roof load limit (not medium or high roof) is: maximum 150kg (with 4 roof bars)
maximum 100kg (with 2 roof bars)

Tailgate load limit (where fitted) is maximum 75kg.

Vehicles with medium or high roof have no provision for roof loads.

* For 12% gradient.

** Unladen weight includes full tank of fuel, excludes crew.

*** Payload with full tank of fuel, excluding crew. Payload = gross vehicle weight - unladen weight.

Weights are for vehicles with standard specification. The addition of factory options or Volkswagen Van Centre fitted accessories may affect unladen weight and payload.

Transporter panel van engine specification.

	84PS TDI PD	102PS TDI PD	130PS TDI PD	174PS TDI PD
Engine type	Transverse, water cooled in line variable turbine geometry turbocharger with intercooler			
Mixture preparation/injection method	Unit injector pump direct injection			
Exhaust emission standard	EU 4			
No. of cylinders	4		5	
Cubic capacity, cm ³	1,896		2,460	
Output, PS at rpm	84 at 3,500	102 at 3,500	130 at 3,500	174 at 3,500
Torque, max. Nm/rpm	200/2,000	250/2,000	340/2,000	400/2,000
Diesel particulate filter	◦	◦	•	•
5-speed manual gearbox	•	•	-	-
6-speed manual gearbox	-	-	•	•
6-speed Tiptronic auto	-	-	•	-
Front wheel drive	•	•	•	•
4MOTION® all wheel drive	-	-	•	-

Electrics.

Alternator	90A	150A
Battery	61Ah (330A)	72Ah (380A)

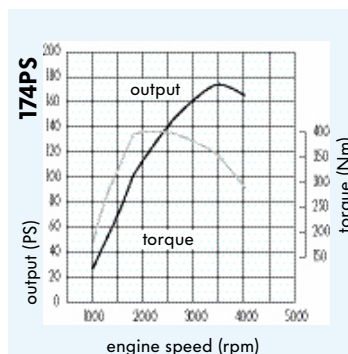
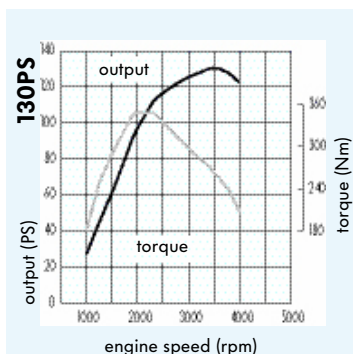
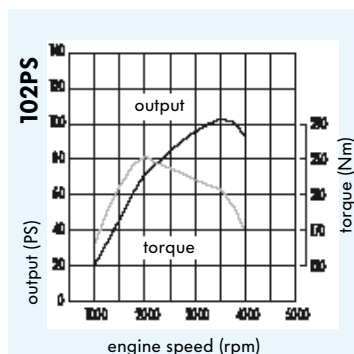
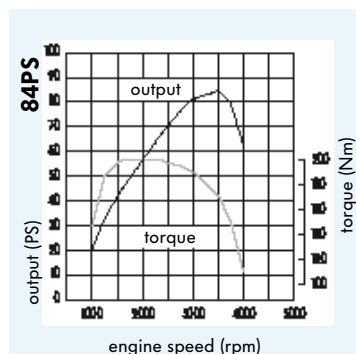

- Available
- Not available
- Optional

4MOTION® – gets to grips with hard work.

The Transporter 4MOTION® all wheel drive system is designed to maintain traction in poor surface conditions like rain, snow, mud or gravel. By distributing drive to the wheels with the most grip, 4MOTION® offers stable road-holding and enhanced safety, reacting to the slightest loss of traction in milliseconds.

Available with the 130PS engine, 4MOTION® is linked through control units to the vehicle's dynamic sensors, engine management system and gearbox, and is designed to be compatible with ABS. All vehicles fitted with 4MOTION® also have a locking rear differential for additional traction in extreme circumstances.



Transporter panel van fuel consumption and performance.

Engine	Urban ⁴ mpg (l/100km)	Extra urban ⁴ mpg (l/100km)	Combined ⁴ mpg (l/100km)	Acceleration 0-62 mph	Top speed (where the law permits) mph	
Panel van with low roof. (all variants short wheelbase and long wheelbase, T26, T28, T30 and T32 ¹)						
84PS TDI PD	1.9 l	30.1 (9.4)	39.2 (7.2)	35.3 (8.0)	23.6	91
102PS TDI PD (not T32)	1.9 l	30.1 (9.4)	42.5 (6.6)	37.2 (7.6)	18.4	99
102PS TDI PD (T32 only)	1.9 l	28.0 (10.1)	40.9 (6.9)	34.9 (8.1)	18.6	96
130PS TDI PD	2.5 l	25.9 (10.9)	41.5 (6.8)	34.0 (8.3)	15.3	104
130PS TDI PD Tiptronic ²	2.5 l	22.4 (12.6)	36.2 (7.8)	29.7 (9.5)	15.4	102
130PS TDI PD 4MOTION ³	2.5 l	23.9 (11.8)	37.2 (7.6)	31.0 (9.1)	16.3	103
174PS TDI PD	2.5 l	26.6 (10.6)	39.2 (7.2)	33.6 (8.4)	12.2	117
Panel van with medium roof. (T28 and T30 short wheelbase and T30 and T32 ¹ long wheelbase)						
84PS TDI PD	1.9 l	30.1 (9.4)	39.2 (7.2)	35.3 (8.0)	24.1	88
102PS TDI PD (not T32)	1.9 l	30.1 (9.4)	42.5 (6.6)	37.2 (7.6)	18.9	96
102PS TDI PD (T32 only)	1.9 l	28.0 (10.1)	40.9 (6.9)	34.9 (8.1)	19.0	94
130PS TDI PD	2.5 l	25.9 (10.9)	41.5 (6.8)	34.0 (8.3)	15.5	101
130PS TDI PD Tiptronic ²	2.5 l	22.4 (12.6)	36.2 (7.8)	29.7 (9.5)	15.6	99
130PS TDI PD 4MOTION ³	2.5 l	23.9 (11.8)	37.2 (7.6)	31.0 (9.1)	16.4	99
174PS TDI PD	2.5 l	26.6 (10.6)	39.2 (7.2)	33.6 (8.4)	12.4	113
Panel van with high roof. (T30 and T32 ¹ long wheelbase only)						
84PS TDI PD	1.9 l	27.7 (10.2)	37.7 (7.5)	33.2 (8.5)	24.7	85
102PS TDI PD (T32 only)	1.9 l	28.0 (10.1)	39.8 (7.1)	34.4 (8.2)	19.3	91
130PS TDI PD	2.5 l	25.9 (10.9)	38.7 (7.3)	32.8 (8.6)	15.8	98
130PS TDI PD Tiptronic ²	2.5 l	22.4 (12.6)	34.4 (8.2)	28.8 (9.8)	15.9	96
130PS TDI PD 4MOTION ³	2.5 l	23.3 (12.1)	34.4 (8.2)	29.4 (9.6)	16.6	96
174PS TDI PD	2.5 l	26.6 (10.6)	37.2 (7.6)	32.5 (8.7)	12.6	108

¹ 84PS not available on T32 models.

² Tiptronic not available on T32 models.

³ 4MOTION[®] only available on T30 models.

⁴ With 50% payload and 80 litre fuel tank capacity.

Tiptronic gearbox.

Fully automatic gear changes or fully manual gear changes at the tip of your finger – you choose!

The Tiptronic gearbox allows you the choice of moving from automatic to manual gear changes simply by moving the gear lever into a second shift gate. This then allows you to change up or down manually through the gears which gives you greater control under certain driving conditions.

Available on the 130PS engine, the Tiptronic gearbox even features a sports mode to maximise responsiveness to engine power.

Tiptronic – it's the best of both worlds!



The Transporter Sportline.
Working hard never looked so good.

SPORTLINE



T30TDI
SPORTLINE



The Sportline range encompasses the highly versatile Transporter. With a choice of three Sportline derivatives, a cavernous panel van in either short or long wheelbase guise or the passenger friendly kombi. A range designed to complement your lifestyle. These exciting models combine desirability and practicality with the effortless performance of a 174PS diesel engine.

For more information, a Sportline brochure is available from your nearest Volkswagen Van Centre.

www.volkswagen-vans.co.uk/sportline

The Volkswagen Crafter.



Load floor showing accommodation of euro-pallets.

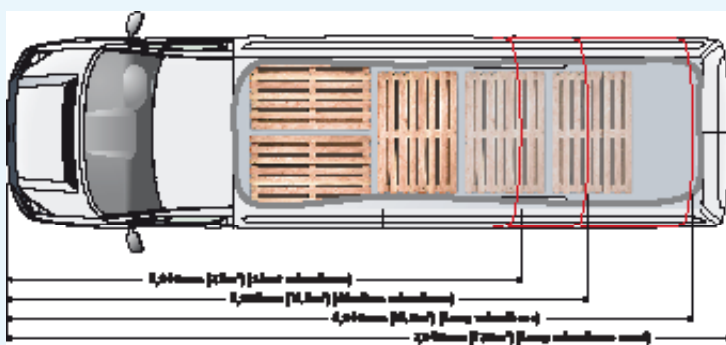

The latest and largest addition to the Volkswagen range, the Crafter's chunky good looks only partially reveal its underlying strengths. Powerful BlueTDI engines with enough torque to satisfy the most demanding business uses, enough space to fit in the most awkward objects, and an array of features to satisfy the most discerning of customers – all make the Crafter the vehicle of choice for a huge range of businesses.

And it is choice that marks the Crafter out as special. Whatever your basic load-carrying requirement is, be it length, weight or size, there is a model in the Crafter range which will do the job.

We detail more of those choices on the following pages, but these are the primary choices you get from the Crafter panel van range:

- Load volumes from 7.5m³ to 17.0m³ (load area takes up to 5 euro-pallets)
- Payloads from 1,011kg up to 2,603kg
- Low, high or extra high roof
- Range of 4 BlueTDI common-rail diesel engines
- 3 wheelbase options
- 4 load lengths available
- Euro V engines (also EEV¹) for a more efficient and environmentally friendly drive.

¹EEV: enhanced environmentally friendly vehicle standard.



And these features are standard across the range:

- ABS*
- ESP* (load adjusting)
- TCS*
- Class-leading side door - loads a euro-pallet sideways
- Full height steel bulkhead
- Load-lashing rings
- Thatcham category 1 alarm system.

Other features and options are listed on the following pages.

* Please refer to the glossary on page 69 of this brochure.



Crafter panel van standard specifications.

Body.

- 25 litre AdBlue® tank
- 75 litre fuel tank with lockable cap
- Black bumpers with integrated front step
- Black wheel centre caps
- Externally adjustable external convex mirrors with indicators
- Front and rear towing eyes, (front only on CR50)
- Heat reflective glass
- Lateral side marker lights (LWB and LWB maxi)
- Sheet steel flooring
- Side sliding door on left
- Tyre repair kit and compressor
- Unglazed rear wing doors

Interior.

Cab area:

- 2 folding and pivoted sun visors
- Driver's seat with height, reach and rake adjustment
- Dual passenger seat with storage box and folding tray in backrest
- Grab handles
- 'Inca' fabric seat covers
- Interior light (including 2 reading lights)
- Rubber floor covering

Storage:

- 5 drinks holders
- Document holder on centre console
- Glove compartment
- Overhead storage (max load 5kg)
- Storage compartment in right step
- Storage compartments (open and closed) in doors
- Storage tray in centre console
- Storage tray on dashboard

Rear:

- Door-activated interior lighting
- Full height steel bulkhead without window
- Interior side door entry step
- Load lashing rings - 2 on 'B' pillar
- Load lashing rings - floor mounted (SWB: 6, MWB: 8, LWB: 10, LWB maxi: 12)
- Rear door interior release lever

Functional.

- 12V socket
- Digital clock
- Digital tachograph (CR50 only)
- Dimmable dashboard illumination
- Electric windows
- Manually controlled heating system with charcoal filter and air recirculation
- Parking lights (SWB and MWB)
- Radio/single CD player, MP3 compatible with 5 speakers
- Remote central locking with 2 remote keys
- Rev counter
- Speed limiter 56mph (90km/h) (CR50 models)
- Warning buzzer for lights left on
- Windscreen wiper with variable intermittent delay and wash/wiper system



Alarm system. Shows sliding bulkhead optional.



Fold down tray - integral to dual passenger seat.



Full height steel bulkhead.

Technical.

- Front and rear axle:
 - Anti-roll bar, front (front and rear on all CR50 and LWB CR35 panel van)
 - Front transverse leaf spring independent suspension
 - Rear rigid axle with leaf springs (CR30 and CR35 panel van only - single leaf, CR50 - triple leaf)
 - Telescopic shock absorbers
- Hydraulic brake system with front ventilated and rear solid disc brakes (front and rear ventilated on CR50)
- Power steering
- Rear wheels:
 - Single: CR30 and CR35
 - Twin: CR50
- Steel wheels: 51/2J x 16 (CR30 and CR50 only)
61/2J x 16 (CR35 only)
- Tyres: 205/75 R16C (CR30 only)
235/65 R16C (CR35 only)
195/75 R16C (CR50 only)

Safety and security.

- 3rd brake light
- ABS: Anti-lock Braking System
- Automatic hazard lights activation under emergency braking
- Brake pad wear, failure and fluid level indicators
- Driver's airbag
- EBA: Electronic Brake Assist
- EBD: Electronic Brakeforce Distribution
- EDL: Electronic Differential Lock
- ESP: Electronic Stabilisation Programme - load adjusting
- Electronic steering wheel lock
- Engine immobiliser 'Transponder'
- Halogen main headlights with headlight range control
- Height adjustable head restraints
- Height adjustable seat belts for all outer cab seats
- Rear fog light
- Seat belt warning light for driver
- TCS: Traction Control System
- Thatcham Category 1 alarm with interior (front and rear) and tow-away protection and back-up horn
- Three point inertia reel seat belts for all seats



Overhead console with two reading lights.



Overhead storage.



Radio/CD player.

Crafter panel van recommended retail prices.

Model	Manufacturer's RRP						Ins. group [#]	
	Basic retail excluding VAT £ [†]	VAT £ [†]	Total retail including VAT £ [†]	Total retail including OTR*				
				excluding VAT £ [†]	including VAT £ [†]			
Panel van short wheelbase.								
CR30	88PS BlueTDI	2EA3A5	17,250.00	2,587.50	19,837.50	18,000.00	20,673.00	7E
	109PS BlueTDI	2EA3B5	18,450.00	2,767.50	21,217.50	19,200.00	22,053.00	8E
Panel van medium wheelbase high roof.								
CR35	88PS BlueTDI	2ED4A5	22,050.00	3,307.50	25,357.50	22,800.00	26,193.00	9E
	109PS BlueTDI	2ED4B5	23,250.00	3,487.50	26,737.50	24,000.00	27,573.00	9E
	109PS BlueTDI Shiftmatic	2ED4BA	24,000.00	3,600.00	27,600.00	24,750.00	28,435.50	9E
	136PS BlueTDI	2ED4C5	24,150.00	3,622.50	27,772.50	24,900.00	28,608.00	9E
	136PS BlueTDI Shiftmatic	2ED4CA	24,900.00	3,735.00	28,635.00	25,650.00	29,470.50	9E
	163PS BlueTDI	2ED4D5	25,350.00	3,802.50	29,152.50	26,100.00	29,988.00	10E
CR50	109PS BlueTDI	2ED5B5	27,550.00	4,132.50	31,682.50	28,340.00	32,558.00	N/A
	109PS BlueTDI Shiftmatic	2ED5BA	28,300.00	4,245.00	32,545.00	29,090.00	33,420.50	N/A
	136PS BlueTDI	2ED5C5	28,480.00	4,272.00	32,752.00	29,270.00	33,627.50	N/A
	136PS BlueTDI Shiftmatic	2ED5CA	29,230.00	4,384.50	33,614.50	30,020.00	34,490.00	N/A
	163PS BlueTDI	2ED5D5	29,410.00	4,411.50	33,821.50	30,200.00	34,697.00	N/A
Panel van long wheelbase high roof.								
CR35	88PS BlueTDI	2EH4A5	22,600.00	3,390.00	25,990.00	23,350.00	26,825.50	9E
	109PS BlueTDI	2EH4B5	23,800.00	3,570.00	27,370.00	24,550.00	28,205.50	9E
	109PS BlueTDI Shiftmatic	2EH4BA	24,550.00	3,682.50	28,232.50	25,300.00	29,068.00	9E
	136PS BlueTDI	2EH4C5	24,700.00	3,705.00	28,405.00	25,450.00	29,240.50	9E
	136PS BlueTDI Shiftmatic	2EH4CA	25,450.00	3,817.50	29,267.50	26,200.00	30,103.00	10E
	163PS BlueTDI	2EH4D5	25,900.00	3,885.00	29,785.00	26,650.00	30,620.50	10E
CR50	109PS BlueTDI	2EH5B5	28,150.00	4,222.50	32,372.50	28,940.00	33,248.00	N/A
	109PS BlueTDI Shiftmatic	2EH5BA	28,900.00	4,335.00	33,235.00	29,690.00	34,110.50	N/A
	136PS BlueTDI	2EH5C5	29,080.00	4,362.00	33,442.00	29,870.00	34,317.50	N/A
	136PS BlueTDI Shiftmatic	2EH5CA	29,830.00	4,474.50	34,304.50	30,620.00	35,180.00	N/A
	163PS BlueTDI	2EH5D5	30,010.00	4,501.50	34,511.50	30,800.00	35,387.00	N/A
Panel van long wheelbase maxi** high roof.								
CR35	109PS BlueTDI	2EX4B5	24,050.00	3,607.50	27,657.50	24,800.00	28,493.00	9E
	109PS BlueTDI Shiftmatic	2EX4BA	24,800.00	3,720.00	28,520.00	25,550.00	29,355.50	9E
	136PS BlueTDI	2EX4C5	24,950.00	3,742.50	28,692.50	25,700.00	29,528.00	9E
	136PS BlueTDI Shiftmatic	2EX4CA	25,700.00	3,855.00	29,555.00	26,450.00	30,390.50	10E
	163PS BlueTDI	2EX4D5	26,150.00	3,922.50	30,072.50	26,900.00	30,908.00	10E
CR50	109PS BlueTDI	2EX5B5	28,650.00	4,297.50	32,947.50	29,440.00	33,823.00	N/A
	109PS BlueTDI Shiftmatic	2EX5BA	29,400.00	4,410.00	33,810.00	30,190.00	34,685.50	N/A
	136PS BlueTDI	2EX5C5	29,580.00	4,437.00	34,017.00	30,370.00	34,892.50	N/A
	136PS BlueTDI Shiftmatic	2EX5CA	30,330.00	4,549.50	34,879.50	31,120.00	35,755.00	N/A
	163PS BlueTDI	2EX5D5	30,510.00	4,576.50	35,086.50	31,300.00	35,962.00	N/A

***OTR (on the road) package for CR30 and CR35 panel vans includes the following:**
 Delivery to retailer £550.00
 Number plates £20.00
 VAT £85.50
 Road fund licence £125.00
 First registration fee £55.00
Total £835.50

***OTR (on the road) package for CR50 panel vans (HGV, Band A) includes the following:**
 Delivery to retailer £550.00
 Number plates £20.00
 VAT £85.50
 Road fund licence £165.00
 First registration fee £55.00
Total £875.50

[†] Calculated at 15% on all products.

[#] Insurance group: As advised by the Association of British Insurers (ABI).

Please see www.abi.org.uk/carinsurance for more information.

** Maxi = extended rear overhang.

Crafter panel van factory options.

	SWB	MWB		LWB		LWB maxi		Manufacturer's RRP		
	low roof	high roof						Basic retail excluding VAT £ †	VAT £ †	Total retail including VAT £ †
		CR30	CR35	CR50	CR35	CR50	CR35			
Paint options.										
Deep black paint - 3902	•	•	•	•	•	•	•	375.00	56.25	431.25
Metallic paint - (includes wooden load floor cover)										
SWB	•	-	-	-	-	-	-	940.00	141.00	1,081.00
MWB	-	•	•	-	-	-	-	1,000.00	150.00	1,150.00
LWB	-	-	-	•	•	-	-	1,065.00	159.75	1,224.75
LWB maxi	-	-	-	-	-	•	•	1,125.00	168.75	1,293.75
Pearl effect paint - (includes wooden load floor cover)										
SWB	•	-	-	-	-	-	-	990.00	148.50	1,138.50
MWB	-	•	•	-	-	-	-	1,050.00	157.50	1,207.50
LWB	-	-	-	•	•	-	-	1,115.00	167.25	1,282.25
LWB maxi	-	-	-	-	-	•	•	1,175.00	176.25	1,351.25
Danish blue paint - 9506	•	•	•	•	•	•	•	100.00	15.00	115.00
Factory fitted options.										
Alloy wheels - 16" (235/65 R16C) (CR30 only)	•	-	-	-	-	-	-	560.00	84.00	644.00
Alloy wheels (CR35 only)	-	•	-	•	-	•	-	420.00	63.00	483.00
Alternator - uprated 180A (not with battery - uprated or heated windscreen, included with air conditioning)	•	•	•	•	•	•	•	115.00	17.25	132.25
Alternator/Battery - uprated (not with heated windscreen, tachograph - digital or CR50)	•	•	-	•	-	•	-	140.00	21.00	161.00
Battery - uprated 110Ah (not with alternator - uprated, heated windscreen or tachograph - digital, not CR50)	•	•	-	•	-	•	-	30.00	4.50	34.50
Cruise control	•	•	•	•	•	•	•	190.00	28.50	218.50
Electric mirrors - heated and adjustable	•	•	•	•	•	•	•	135.00	20.25	155.25
Fog lights - front, integrated in bumper	•	•	•	•	•	•	•	100.00	15.00	115.00
Headlight washers (included with visibility pack)	•	•	•	•	•	•	•	180.00	27.00	207.00
Heated windscreen (only with visibility pack, not with alternator - uprated, alternator/battery uprated or battery - uprated)	•	•	•	•	•	•	•	135.00	20.25	155.25
Keys - 2 additional keys	•	•	•	•	•	•	•	50.00	7.50	57.50
Load floor cover - wooden - (not with load lashing rings - deleted)										
SWB ¹	•	-	-	-	-	-	-	240.00	36.00	276.00
MWB ¹	-	•	•	-	-	-	-	300.00	45.00	345.00
LWB ¹	-	-	-	•	•	-	-	365.00	54.75	419.75
LWB maxi ¹	-	-	-	-	-	•	•	425.00	63.75	488.75

• Options.

- Not available.

s Standard equipment.

† Calculated at 15% on all products.

¹ Load floor cover: Standard with metallic/pearl effect paint.



Multi-function steering wheel.

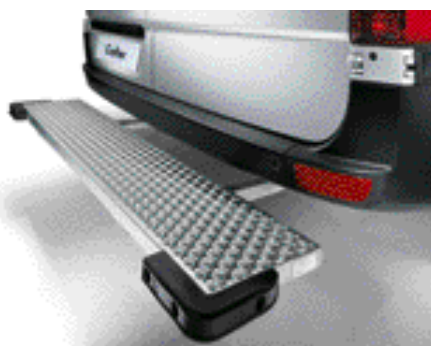

Full width rear step.



Sliding and tilting sunroof.

Crafter panel van factory options. (continued)

	SWB	MWB		LWB		LWB maxi		Manufacturer's RRP			
	low roof	high roof						Basic retail excluding VAT £ †	Total retail including VAT £ †	Total retail including VAT £ †	
		CR30	CR35	CR50	CR35	CR50	CR35				CR50
Factory fitted options. (continued)											
Load floor cover - rubber - (not with load lashing rings - deleted)											
SWB	•	-	-	-	-	-	-	330.00	49.50	379.50	
MWB	-	•	•	-	-	-	-	410.00	61.50	471.50	
LWB	-	-	-	•	•	-	-	510.00	76.50	586.50	
LWB maxi	-	-	-	-	-	•	•	590.00	88.50	678.50	
Load lashing rails - on load floor (only with load floor cover - wooden, not with load floor cover - rubber)	•	•	•	•	•	•	•	115.00	17.25	132.25	
Load lashing rails - on side panel	•	•	•	•	•	•	•	115.00	17.25	132.25	
Load lashing rails - on side panel and load floor (only with load floor cover - wooden, not with load floor cover - rubber)	•	•	•	•	•	•	•	230.00	34.50	264.50	
Load lashing rails - on side panel and roof frame	•	•	•	•	•	•	•	205.00	30.75	235.75	
Load lashing rails - on side panel, load floor and roof frame (only with load floor cover - wooden, not with load floor cover - rubber)	•	•	•	•	•	•	•	320.00	48.00	368.00	
Load side lining - hardboard											
SWB	•	-	-	-	-	-	-	85.00	12.75	97.75	
MWB	-	•	•	-	-	-	-	105.00	15.75	120.75	
LWB	-	-	-	•	•	-	-	120.00	18.00	138.00	
LWB maxi	-	-	-	-	-	•	•	135.00	20.25	155.25	
Load side lining - plywood											
SWB	•	-	-	-	-	-	-	245.00	36.75	281.75	
MWB	-	•	•	-	-	-	-	290.00	43.50	333.50	
LWB	-	-	-	•	•	-	-	345.00	51.75	396.75	
LWB maxi	-	-	-	-	-	•	•	395.00	59.25	454.25	
Mud flaps - front	•	•	•	•	•	•	•	25.00	3.75	28.75	
Mud flaps - front and rear	•	•	•	•	•	•	•	50.00	7.50	57.50	
Parking brake - hill hold control (standard on Shiftmatic)	•	•	•	•	•	•	•	60.00	9.00	69.00	
Parking sensors - front and rear (only with electric mirrors, not with step - rear, full width)	•	•	•	•	•	•	•	280.00	42.00	322.00	
Reversing camera - includes 7" monitor on dashboard (not with parking sensors)	•	•	•	•	•	•	•	740.00	110.00	851.00	
Reversing camera with front and rear parking sensors - includes 7" monitor on dashboard (only with electric mirrors, not with step - rear, full width)	•	•	•	•	•	•	•	1,025.00	153.75	1,178.75	
Roof load rack preparation	•	•	•	•	•	•	•	80.00	12.00	92.00	
Roof ventilator - in passenger/load compartment	•	•	•	•	•	•	•	135.00	20.25	155.25	
Satellite navigation A - colour screen with arrow navigation (CD)	•	•	•	•	•	•	•	1,030.00	154.50	1,184.50	
Satellite navigation B - colour screen with map navigation (DVD)	•	•	•	•	•	•	•	1,620.00	243.00	1,863.00	
Side marker lights (MWB only, standard on LWB and LWB maxi)	-	•	•	s	s	s	s	35.00	5.25	40.25	



Bulkhead pack A. Shows optional second sliding door.



Air conditioning 'Climatic'.



Satellite navigation.

	SWB	MWB		LWB		LWB maxi		Manufacturer's RRP		
	low roof	high roof						Basic retail excluding VAT £ †	VAT £ †	Total retail including VAT £ †
	CR30	CR35	CR50	CR35	CR50	CR35	CR50			

Factory fitted options. (continued)

Skylight - in passenger/load compartment, fixed											
SWB	•	-	-	-	-	-	-	60.00	9.00	69.00	
MWB	-	•	•	-	-	-	-	120.00	18.00	138.00	
LWB and LWB maxi	-	-	-	•	•	•	•	160.00	24.00	184.00	
Spare wheel - steel (not with step - rear, full width)	•	•	•	•	•	•	•	0.00	0.00	0.00	
Speed limiter 90km/h (standard with CR50)	•	•	s	•	s	•	s	35.00	5.25	40.25	
Speed limiter 100km/h	•	•	-	•	-	•	-	35.00	5.25	40.25	
Speed limiter 120km/h (not CR50)	•	•	-	•	-	•	-	35.00	5.25	40.25	
Steering wheel - height and reach adjustable	•	•	•	•	•	•	•	60.00	9.00	69.00	
Steering wheel - multi-function, includes trip computer (included with satellite navigation packs)	•	•	•	•	•	•	•	210.00	31.50	241.50	
Step - rear, full width (not with parking sensors - front and rear, towbars or spare wheel - steel) ²	•	•	•	•	•	•	•	190.00	28.50	218.50	
Step - rear, in bumper (not with towbars or MWB)	•	-	-	•	•	•	•	115.00	17.25	132.25	
Step - rear, in bumper, includes side marker lights (MWB only, not with towbars)	-	•	•	-	-	-	-	115.00	17.75	132.25	
Sunroof - in cab, sliding/tilting, electric (only with low roof)	•	•	•	-	-	-	-	455.00	68.25	523.25	
Tachograph - digital (standard on CR50, not with alternator/battery - uprated or battery - uprated)	•	•	s	•	s	•	s	400.00	60.00	460.00	
Temperature display - external (included with air conditioning, satellite navigation packs and steering wheel - multi-function)	•	•	•	•	•	•	•	85.00	12.75	97.75	
Tyre pressure warning light (CR35 only)	-	•	-	•	-	•	-	260.00	39.00	299.00	
Tyres - all weather	-	•	-	•	-	•	-	85.00	12.75	97.75	

Options packs.

Visibility pack - rain sensor, headlamp washers and automatic light sensor	•	•	•	•	•	•	•	300.00	45.00	345.00
---	---	---	---	---	---	---	---	--------	-------	--------

Airbag packs.

Airbag pack A - passenger	•	•	•	•	•	•	•	210.00	31.50	241.50
Airbag pack B - passenger, side and front curtain airbags (only with seat packs B or D)	•	•	•	•	•	•	•	735.00	110.25	845.25

- Options.
- Not available.
- s Standard equipment.

² Step - rear: Full width step has only 1 front towing eye on CR35 models.

† Calculated at 15% on all products.



16" alloy wheels.



Cruise control.



Electric mirrors.

Crafter panel van factory options. (continued)

	SWB	MWB		LWB		LWB maxi		Manufacturer's RRP		
	low roof	high roof						Basic retail excluding VAT £ †	VAT £ †	Total retail including VAT £ †
		CR30	CR35	CR50	CR35	CR50	CR35			
Bulkhead packs.										
Bulkhead pack A - high with window	•	•	•	•	•	•	•	50.00	7.50	57.50
Bulkhead pack B - high with sliding window	•	•	•	•	•	•	•	170.00	25.50	195.50
Bulkhead pack E - deleted (not with load floor cover wooden/rubber or metallic/pearl effect paint)	•	•	•	•	•	•	•	0.00	0.00	0.00
Bulkhead pack F - sliding door in bulkhead, includes folding single passenger seat on bulkhead (not with roof packs)	-	•	•	•	•	•	•	690.00	103.50	793.50
Bulkhead pack G - sliding door in bulkhead, includes folding single passenger seat on bulkhead (only with roof pack B or C)	-	•	•	•	•	•	•	690.00	103.50	793.50
Door packs.										
Rear doors - wing doors with heated windows and wash/wipe, dipping rear view mirror and storage nets on rear doors	•	•	•	•	•	•	•	270.00	40.50	310.50
Rear doors - 270° hinges (not SWB)	-	•	•	•	•	•	•	255.00	38.25	293.25
Side door pack A - right only (no left door)	•	•	•	•	•	•	•	0.00	0.00	0.00
Side door pack B - left and right	•	•	•	•	•	•	•	370.00	55.50	425.50
Side door pack C - deleted, left	•	•	•	•	•	•	•	0.00	0.00	0.00
Heating and ventilation.										
Air conditioning - 'Climatic', includes temperature display, external ²	•	•	•	•	•	•	•	925.00	138.75	1,063.75
Roof packs.										
Roof pack A - low roof (MWB only)	-	•	•	-	-	-	-	-800.00	-120.00	-920.00
Roof pack B - extra high roof, white	-	•	•	•	•	•	•	1,140.00	171.00	1,311.00
Roof pack C - extra high roof, body-coloured (exterior only)	-	•	•	•	•	•	•	1,405.00	210.75	1,615.75

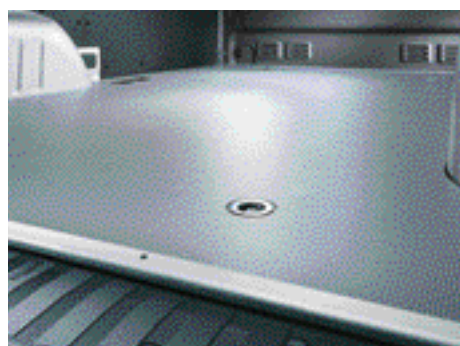

Load floor cover.

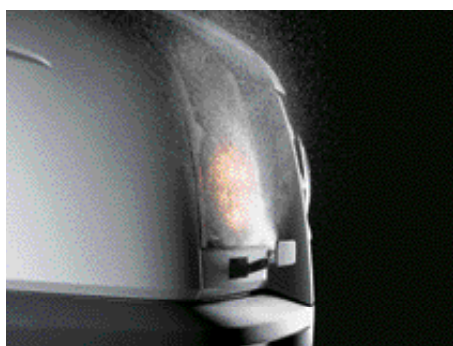

Headlight washers.



Skylights in load compartment.

	SWB	MWB		LWB		LWB maxi		Manufacturer's RRP		
	low roof	high roof						Basic retail excluding VAT £ †	VAT £ †	Total retail including VAT £ †
		CR30	CR35	CR50	CR35	CR50	CR35			

Seat packs.

Seats - 'Box' fabric upholstery (not with seat pack K)	•	•	•	•	•	•	•	55.00	8.25	63.25
Seats - leatherette upholstery (not with seat pack K)	•	•	•	•	•	•	•	30.00	4.50	34.50
Seat pack A - drivers seat with lumbar support	•	•	•	•	•	•	•	60.00	9.00	69.00
Seat pack B - driver and single passenger seat with lumbar support and inner armrest	•	•	•	•	•	•	•	120.00	18.00	138.00
Seat pack C - driver only with suspension and lumbar support	•	•	•	•	•	•	•	200.00	30.00	230.00
Seat pack D - driver and single passenger seat with suspension, lumbar support and inner armrest	•	•	•	•	•	•	•	320.00	48.00	368.00
Seat pack G - heated driver's seat	•	•	•	•	•	•	•	95.00	14.25	109.25
Seat pack H - heated driver and front passenger seats	•	•	•	•	•	•	•	190.00	28.50	218.50
Seat pack K - folding single passenger seat (not with airbag packs or seat pack H) ⁴	•	•	•	•	•	•	•	230.00	34.50	264.50

Towbar packs.

Towbar pack A - preparation, with socket ⁵	•	•	•	•	•	•	•	105.00	15.75	120.75
Towbar pack B - preparation with bracket, socket and cable ^{5, 6}	•	•	•	•	•	•	•	175.00	26.25	201.25
Towbar pack C (towing weight 2.0t) - fixed ball with 13 pin socket (not with rear steps) ^{5, 6, 7}	•	•	•	•	•	•	•	295.00	44.25	399.25
Towbar pack D (towing weight 2.0t) - removable ball (not with rear steps) ^{5, 6, 7}	•	•	•	•	•	•	•	405.00	60.75	465.75
Towbar pack E (towing weight 2.0t) - jaw type with 13 pin socket (not with rear steps) ^{5, 6, 7}	•	•	•	•	•	•	•	300.00	45.00	345.00

• Options.

- Not available.

s Standard equipment.

† Calculated at 15% on all products.

³ **Air conditioning:** Alternator updated to 180A.

⁴ **Seat pack K:** Only with standard 'Inca' trim.

⁵ **Towbars:** In most circumstances, for commercial use, a tachograph will be required when towing equipment is fitted.

⁶ **Towbars:** Only 1 front towing eye on CR30 and CR35 models.

⁷ **Towbars:** An adaptor is available from Volkswagen Van Centres, to allow connection to twin 7 pin sockets.



Towbars.



Fog lights.



Automatic light sensor.

Crafter panel van dimensions and weights.

CR30 panel van short wheelbase low roof.

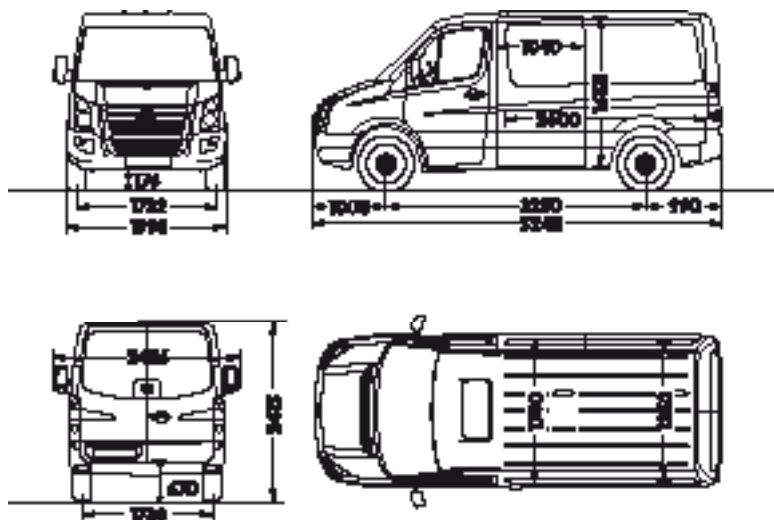

		Roof height low
Wheelbase		3,250
Load compartment	volume	7.5m ³
Lateral sliding door	width	1,040
	height	1,520
Rear doors	width	1,565
	height	1,540
Turning circle (wall to wall)		12.3m

Dimensions in mm unless otherwise indicated.

Gross vehicle weight Model	Engine	Axle load limit front / rear kg	Trailer weight braked / unbraked* kg	Gross train weight kg	Unladen weight** kg	Payload*** kg
CR30 3,000	88PS BlueTDI	1,650 / 1,800	2,000 / 750	5,000	1,989	1,011
	109PS BlueTDI	1,650 / 1,800	2,000 / 750	5,000	1,989	1,011

CR35 / CR50 panel van medium wheelbase high and extra high roof.

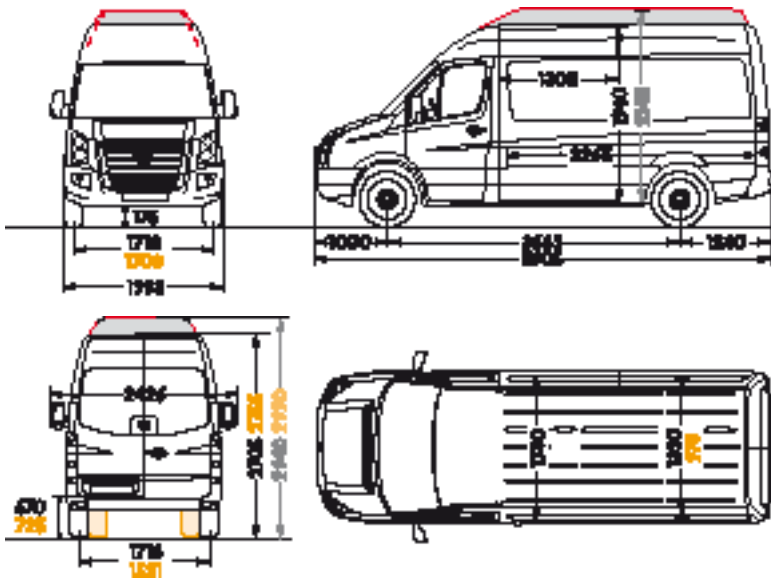

	Roof height	
	high	extra high
Wheelbase	3,665	3,665
Load compartment volume	11.0m ³	11.5m ³
Lateral sliding door width	1,300	1,300
height	1,820	1,820
Rear doors width	1,565	1,565
height	1,840	1,840
Turning circle (wall to wall)	13.6m	13.6m

Figures in orange indicate CR50 dimensions, where different.
Dimensions in mm unless otherwise indicated.

□ Indicates optional roof height.

The height measurements listed for dimensions are based on vehicles with standard specification, and may differ by approx ± 40mm depending on equipment fitted. Please note vehicle drawings are not to scale.

Gross vehicle weight	Engine	Axle load limit front / rear	Trailer weight braked / unbraked*	Gross train weight	Unladen weight**	Payload***
Model kg		kg	kg	kg	kg	kg
CR35 3,500	88PS BlueTDI	1,650 / 2,250	2,000 / 750	5,500	2,113	1,387
	109PS BlueTDI	1,650 / 2,250	2,000 / 750	5,500	2,113	1,387
	109PS BlueTDI Shiftmatic	1,650 / 2,250	2,000 / 750	5,500	2,111	1,389
	136PS BlueTDI	1,650 / 2,250	2,000 / 750	5,500	2,113	1,387
	136PS BlueTDI Shiftmatic	1,650 / 2,250	2,000 / 750	5,500	2,111	1,389
	163PS BlueTDI	1,650 / 2,250	2,000 / 750	5,500	2,113	1,387
CR50 5,000	109PS BlueTDI	1,850 / 3,500	2,000 / 750	7,000	2,399	2,601
	109PS BlueTDI Shiftmatic	1,850 / 3,500	2,000 / 750	7,000	2,397	2,603
	136PS BlueTDI	1,850 / 3,500	2,000 / 750	7,000	2,399	2,601
	136PS BlueTDI Shiftmatic	1,850 / 3,500	2,000 / 750	7,000	2,397	2,603
	163PS BlueTDI	1,850 / 3,500	3,000 / 750	7,000	2,399	2,601

Roof load limit 300kg (low roof); 150kg (high roof).

Trailer nose weight 100kg.

All data is provisional.

* For 12% gradient.

** Unladen weight includes full tank of fuel and driver (75kg), excludes crew.

*** Payload with full tank of fuel and driver (75kg), excluding crew.

Payload = gross vehicle weight - unladen weight.

Weights are for vehicles with standard specification. The addition of factory options or Volkswagen Van Centre fitted accessories may affect unladen weight and payload.

Please note: The CR35 model has a designed 'Trailer weight braked' of 2,800kg, so it is possible for an aftermarket braked towbar of up to 2,800kg to be fitted providing that the vehicle plating is also retro-updated to a maximum of 2,800kg (and 'Gross train weight' of 6,300kg). Please contact your nearest Van Centre for details, including available axle ratio options to suit vehicle requirements.

Crafter panel van dimensions and weights. (continued)

CR35 / CR50 panel van long wheelbase high and extra high roof.

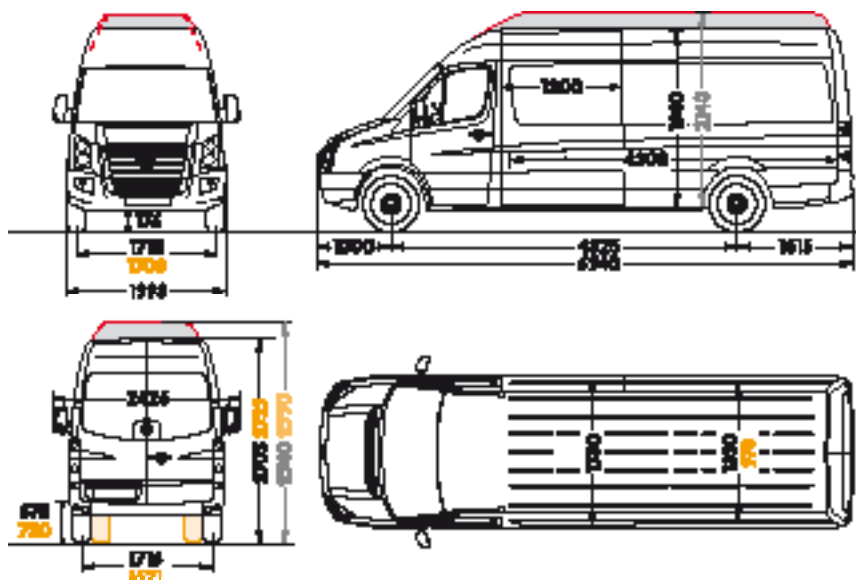

	Roof height	
	high	extra high
Wheelbase	4,325	4,325
Load compartment volume	14.0m ³	15.0m ³
Lateral sliding door width	1,300	1,300
height	1,820	1,820
Rear doors width	1,565	1,565
height	1,840	1,840
Turning circle (wall to wall)	15.6m	15.6m

Figures in orange indicate CR50 dimensions, where different.

Dimensions in mm unless otherwise indicated.

□ Indicates optional roof height.

Gross vehicle weight	Model	Engine	Axle load limit front / rear kg	Trailer weight braked / unbraked* kg	Gross train weight kg	Unladen weight** kg	Payload*** kg
CR35 3,500		88PS BlueTDI	1,650 / 2,250	2,000 / 750	5,500	2,246	1,254
		109PS BlueTDI	1,650 / 2,250	2,000 / 750	5,500	2,246	1,254
		109PS BlueTDI Shiftmatic	1,650 / 2,250	2,000 / 750	5,500	2,244	1,256
		136PS BlueTDI	1,650 / 2,250	2,000 / 750	5,500	2,246	1,254
		136PS BlueTDI Shiftmatic	1,650 / 2,250	2,000 / 750	5,500	2,244	1,256
		163PS BlueTDI	1,650 / 2,250	2,000 / 750	5,500	2,246	1,254
CR50 5,000		109PS BlueTDI	1,850 / 3,500	2,000 / 750	7,000	2,566	2,434
		109PS BlueTDI Shiftmatic	1,850 / 3,500	2,000 / 750	7,000	2,564	2,436
		136PS BlueTDI	1,850 / 3,500	2,000 / 750	7,000	2,566	2,434
		136PS BlueTDI Shiftmatic	1,850 / 3,500	2,000 / 750	7,000	2,564	2,436
		163PS BlueTDI	1,850 / 3,500	3,000 / 750	7,000	2,566	2,434

CR35 / CR50 panel van long wheelbase maxi[†] high and extra high roof.

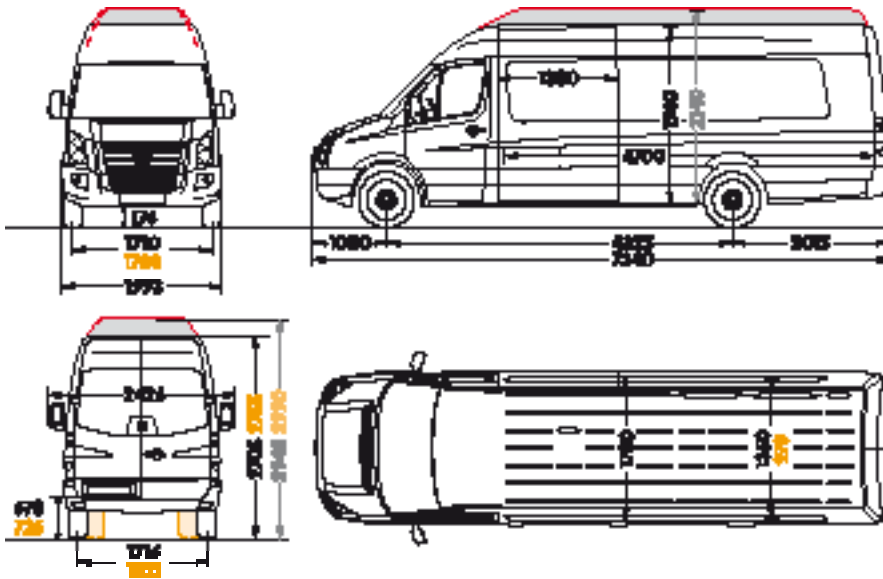

	Roof height	
	high	extra high
Wheelbase	4,325	4,325
Load compartment volume	15.5m ³	17m ³
Lateral sliding door width	1,300	1,300
height	1,820	1,820
Rear doors width	1,565	1,565
height	1,840	1,840
Turning circle (wall to wall)	15.6m	15.6m

Figures in orange indicate CR50 dimensions, where different.
Dimensions in mm unless otherwise indicated.

□ Indicates optional roof height.

The height measurements listed for dimensions are based on vehicles with standard specification, and may differ by approx ± 40mm depending on equipment fitted. Please note vehicle drawings are not to scale.

Gross vehicle weight	Engine	Axle load limit front / rear	Trailer weight braked / unbraked*	Gross train weight	Unladen weight**	Payload***
Model kg		kg	kg	kg	kg	kg
CR35 3,500	109PS BlueTDI	1,650 / 2,250	2,000 / 750	5,500	2,298	1,202
	109PS BlueTDI Shiftmatic	1,650 / 2,250	2,000 / 750	5,500	2,296	1,204
	136PS BlueTDI	1,650 / 2,250	2,000 / 750	5,500	2,298	1,202
	136PS BlueTDI Shiftmatic	1,650 / 2,250	2,000 / 750	5,500	2,296	1,204
	163PS BlueTDI	1,650 / 2,250	2,000 / 750	5,500	2,298	1,202
CR50 5,000	109PS BlueTDI	1,850 / 3,500	2,000 / 750	7,000	2,610	2,390
	109PS BlueTDI Shiftmatic	1,850 / 3,500	2,000 / 750	7,000	2,608	2,392
	136PS BlueTDI	1,850 / 3,500	2,000 / 750	7,000	2,610	2,390
	136PS BlueTDI Shiftmatic	1,850 / 3,500	2,000 / 750	7,000	2,608	2,392
	163PS BlueTDI	1,850 / 3,500	3,000 / 750	7,000	2,610	2,390

Roof load limit 300kg (low roof); 150kg (high roof).

Trailer nose weight 100kg.

All data is provisional.

[†] Maxi = extended rear overhang.

* For 12% gradient.

** Unladen weight includes full tank of fuel and driver (75kg), excludes crew.

*** Payload with full tank of fuel and driver (75kg), excluding crew.

Payload = gross vehicle weight - unladen weight.

Weights are for vehicles with standard specification. The addition of factory options or Volkswagen Van Centre fitted accessories may affect unladen weight and payload.

Please note: The CR35 model has a designed 'Trailer weight braked' of 2,800kg, so it is possible for an aftermarket braked towbar of up to 2,800kg to be fitted providing that the vehicle plating is also retro-updated to a maximum of 2,800kg (and 'Gross train weight' of 6,300kg). Please contact your nearest Van Centre for details, including available axle ratio options to suit vehicle requirements.

Crafter panel van engine specifications.

	88PS BlueTDI	109PS BlueTDI	136PS BlueTDI	163PS BlueTDI
Mixture preparation/injection method	Common-rail direct injection			
Exhaust emission standard	EURO V and EEV†			
No. of cylinders	5			
Cubic capacity, cm ³	2,461			
Output, PS at rpm	88 at 3,300	109 at 3,300	136 at 3,500	163 at 3,500
Torque, max. Nm/rpm	250/1,900-2,300	300/1,900-2,300	330/2,000	360/2,200
Diesel particulate filter	•	•	•	•
6-speed manual gearbox	•	•	•	•
6-speed Shiftmatic gearbox	-	•	•	-
Rear wheel drive	•	•	•	•

Electrics.

Alternator	110A
Battery	72Ah (380A) 100Ah (450A)
	- CR30 and CR35 - CR50

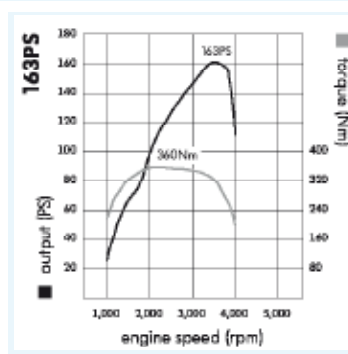
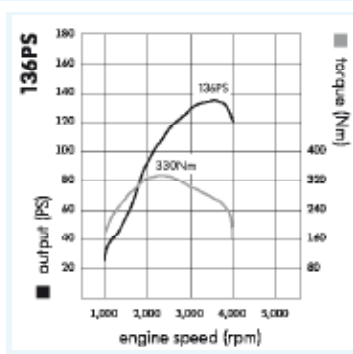
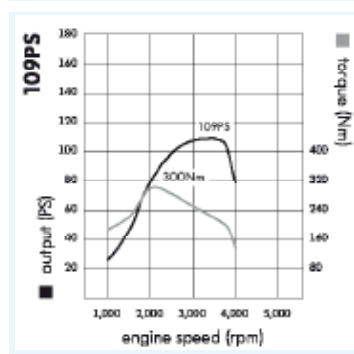
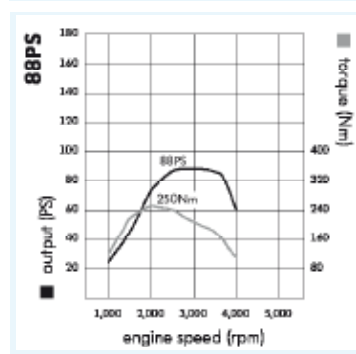

• Available

- Not available

† Enhanced Environmentally Friendly Vehicle - the emission measure below the maximum limit for EURO V standards.

Shiftmatic.

This lightweight gearbox combines the functionality of an automatic with the characteristics of a manual.

The Shiftmatic can be operated in either manual or automatic mode. In automatic mode all gears are selected automatically by the gearbox control unit, with a kick-down function for those times where extra acceleration is needed.

In manual mode, the driver pushes the gear lever forwards to change down, or backwards to change up, giving all the benefits of a manual gearbox without the need for a manual clutch – perfect for city driving.



Crafter panel van fuel consumption and performance.

Model	Engine		Urban ¹ mpg (l/100km)	Extra urban ¹ mpg (l/100km)	Combined ¹ mpg (l/100km)	Top speed (where the law permits) mph
Panel van with low roof. (short wheelbase)						
CR30	88PS BlueTDI	2.5 litre	22.4 (12.6)	33.6 (8.4)	28.5 (9.9)	85
	109PS BlueTDI	2.5 litre	23.5 (12.0)	34.4 (8.2)	29.4 (9.6)	91
Panel van with high roof. (medium wheelbase and long wheelbase)						
CR35	88PS BlueTDI	2.5 litre	22.4 (12.6)	33.6 (8.4)	28.5 (9.9)	85
	109PS BlueTDI	2.5 litre	23.5 (12.0)	34.4 (8.2)	29.4 (9.6)	91
	109PS BlueTDI Shiftmatic	2.5 litre	27.4 (10.3)	33.2 (8.5)	31.0 (9.1)	89
	136PS BlueTDI	2.5 litre	23.2 (12.2)	33.6 (8.4)	28.8 (9.8)	96
	136PS BlueTDI Shiftmatic	2.5 litre	27.4 (10.3)	33.2 (8.5)	31.0 (9.1)	93
	163PS BlueTDI	2.5 litre	23.0 (12.3)	33.6 (8.4)	28.8 (9.8)	99
CR50	109PS BlueTDI	2.5 litre	TBA	TBA	TBA	56 (83)
	109PS BlueTDI Shiftmatic	2.5 litre	TBA	TBA	TBA	56 (80)
	136PS BlueTDI	2.5 litre	TBA	TBA	TBA	56 (86)
	136PS BlueTDI Shiftmatic	2.5 litre	TBA	TBA	TBA	56 (84)
	163PS BlueTDI	2.5 litre	TBA	TBA	TBA	56 (94)
Panel van with optional extra high roof. (medium wheelbase and long wheelbase)						
CR35	88PS BlueTDI	2.5 litre	22.4 (12.6)	33.6 (8.4)	28.5 (9.9)	81
	109PS BlueTDI	2.5 litre	23.5 (12.0)	34.4 (8.2)	29.4 (9.6)	88
	109PS BlueTDI Shiftmatic	2.5 litre	27.4 (10.3)	33.2 (8.5)	31.0 (9.1)	89
	136PS BlueTDI	2.5 litre	23.2 (12.2)	33.6 (8.4)	28.8 (9.8)	91
	136PS BlueTDI Shiftmatic	2.5 litre	27.4 (10.3)	33.2 (8.5)	31.0 (9.1)	93
	163PS BlueTDI	2.5 litre	23.0 (12.3)	33.6 (8.4)	28.8 (9.8)	97
CR50	109PS BlueTDI	2.5 litre	TBA	TBA	TBA	56 (80)
	109PS BlueTDI Shiftmatic	2.5 litre	TBA	TBA	TBA	56 (78)
	136PS BlueTDI	2.5 litre	TBA	TBA	TBA	56 (83)
	136PS BlueTDI Shiftmatic	2.5 litre	TBA	TBA	TBA	56 (81)
	163PS BlueTDI	2.5 litre	TBA	TBA	TBA	56 (91)

¹ With 50% payload.

The figures listed apply to vehicles with manual gearbox, without optional extras.

Figures in square brackets show top speed for vehicles without speed limiter.

Figures above show vehicles fitted with standard axle ratio.

Paint colours and upholstery.

Solid paint.

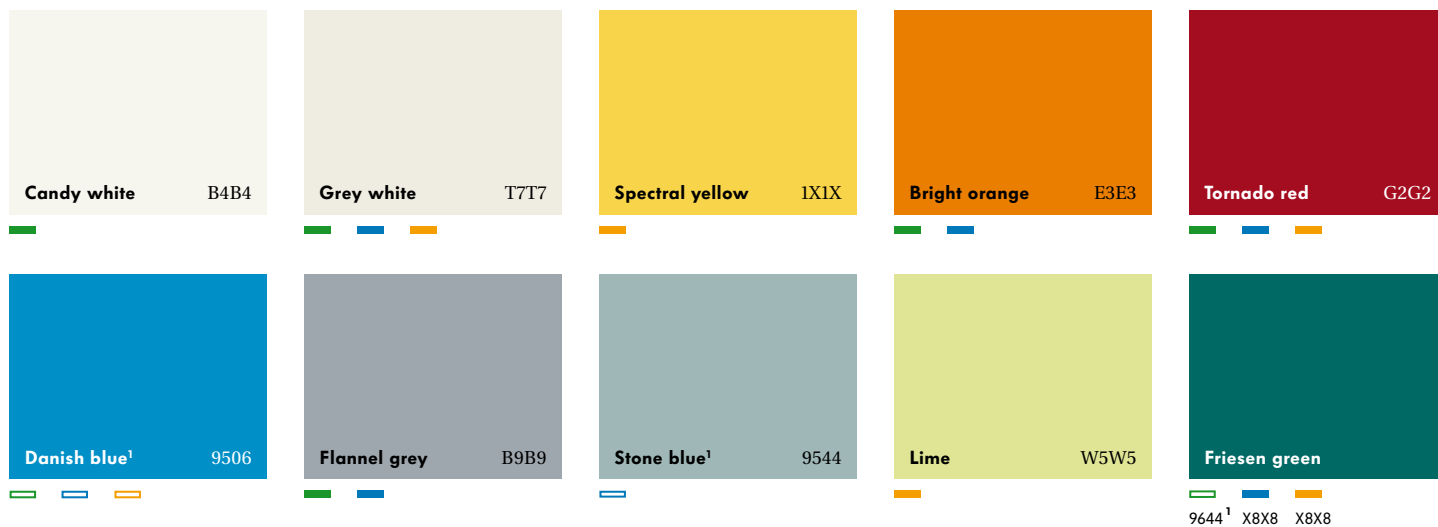

Metallic paint¹

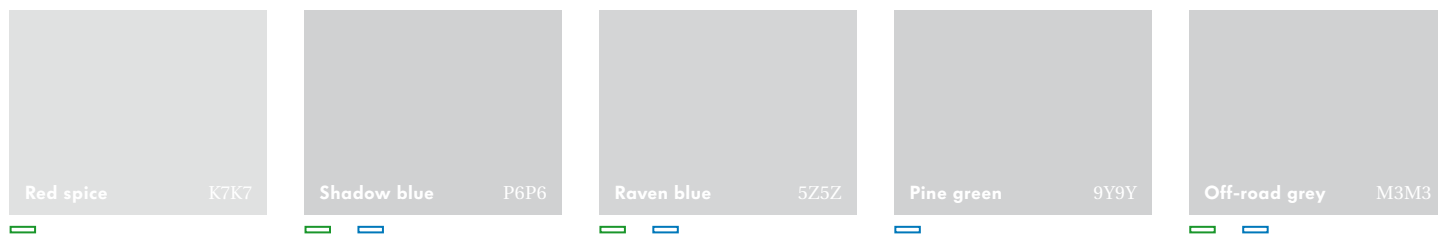





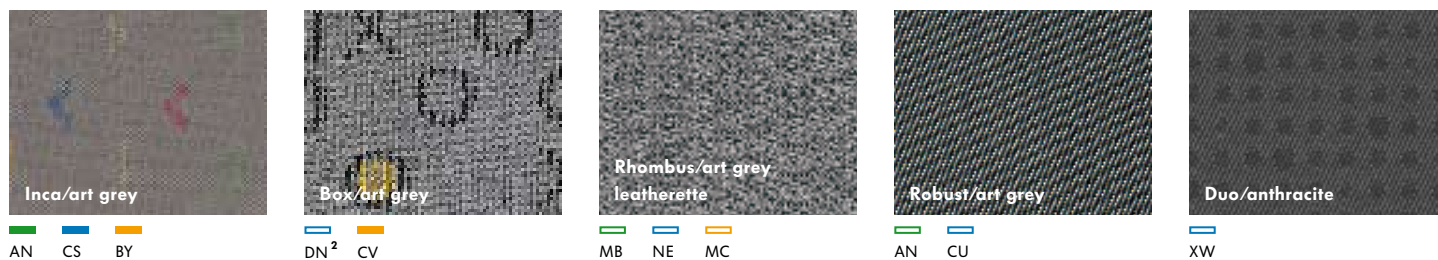

Pearl effect paint¹

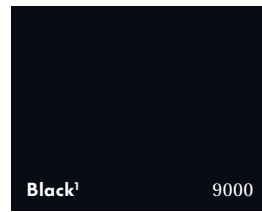
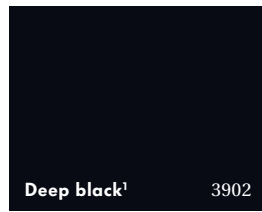
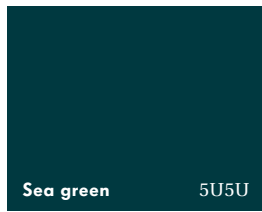

Upholstery.





-  Available on Caddy.
-  Available on Transporter.
-  Available on Crafter.
-  Available on Caddy at extra cost.
-  Available on Transporter at extra cost.
-  Available on Crafter at extra cost.

Please note: Print processes do not allow exact reproduction of the paint and upholstery colours.

¹ These colours are available at extra cost.

² Box/art grey cloth is only available on Transporter models as part of the optional cab comfort pack.

Accessories.

Our comprehensive range of Volkswagen Commercial Vehicle accessories is constantly evolving to ensure that we can satisfy your every need.

Whether you are looking to increase the flexibility of your vehicle or opting for an aesthetic enhancement, our vast array of accessory products coupled with our dedicated network of Van Centres will help you individualise an already well appointed vehicle.

For the full range of commercial vehicle products and latest additions to the accessories range, visit our website www.volkswagen-vans.co.uk/accessories or pick up a commercial vehicles accessory brochure from your nearest Van Centre.

Our Volkswagen approved accessories come with a **standard 3 years warranty** when purchased with a new vehicle or **2 years warranty** if you purchase an accessory after taking delivery of your vehicle.

Sport and styling.



Van care.



Safety.



Leather.



Load securing.



Media.

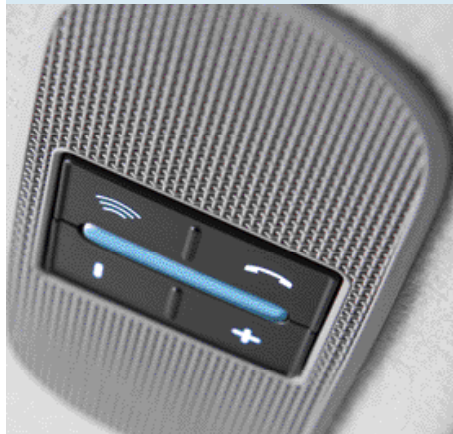

Security.



Touring.



Protection.



Towing.



Volkswagen service for your peace of mind.



The Volkswagen warranty.

Three-year warranty*.

All Volkswagen vans come with a three-year/100,000 miles warranty, which protects your vehicle against the failure of most mechanical and electrical components due to manufacturing defects. This comprises a two-year manufacturer's warranty with unlimited mileage plus a further one-year/100,000 miles (whichever is soonest) Van Centre warranty. Should the mileage exceed 100,000 miles within the first two years, the manufacturer's two-year warranty will still be valid. If an additional warranty for subsequent years or higher mileage is desired, it may be purchased from an authorised Volkswagen Van Centre or Van Service Centre; however, this additional warranty must be purchased before the mileage reaches 100,000.

Three-year Paint warranty*.

The paintwork of all vehicles is covered against manufacturing defects for a period of three years. Naturally, the vehicle must be cared for in compliance with the operating instructions which will be found in your owners handbook.

12-year Body Protection warranty*.

The internal body sections and panels of all vehicles are covered against rusting through from the inside for 12 years. Naturally, the vehicle must be cared for in compliance with the operating instructions.

Service intervals for Diesel Engines.**

The LongLife Service regime is so called because there are no set service intervals. The interval between services, depending on how you drive your vehicle and the conditions of use, can be anywhere up to a maximum of approximately 18,000 miles or 24 months on Caddys and Transporters or 25,000 miles or 24 months on Crafters (whichever comes first). The Service Interval Display in the instrument panel will indicate when a service is required.

If you would like a more traditional service regime the vehicle can be adapted by your authorised Volkswagen Van Centre or Van Service Centre to the Time/Distance regime. This can be done at the point of vehicle sale or when an inspection service is carried out. An oil change is required at every 10,000 miles for Caddys and Transporters and 12,500 for Crafters on the Time/Distance regime.

Volkswagen Commercial Vehicle Finance†.

Volkswagen Commercial Vehicle Finance offers a dedicated service to meet the needs of both the business user and the private motorist. They can help you choose the right type of finance package to meet your specific requirements. Please consult your authorised Volkswagen Van Centre for details.

† Volkswagen Commercial Vehicle Finance is a trading name of Volkswagen Financial Services (UK) Limited. Subject to status. Finance available to over 18s only. Indemnities may be required.



Volkswagen Van Insurance.

Competitive insurance premiums are available to Volkswagen owners through Volkswagen Van Insurance. Volkswagen Van Insurance includes Genuine Volkswagen Parts and a three year repairer guarantee, when using our approved network. The cover also includes a courtesy vehicle following an accident or recovered theft of your vehicle and up to £1,000 of 'tools in transit' cover is included at no additional cost. For a quotation, or to arrange complimentary seven day insurance, telephone **0800 051 3138**.

Exclusions apply. Volkswagen Van Insurance is underwritten and administered by Zurich Insurance plc. Volkswagen Van Insurance is a trading name of Volkswagen Insurance Service (Great Britain) Limited which is an appointed representative of Volkswagen Financial Services (UK) Limited, Freepost VWFS. Volkswagen Financial Services (UK) Limited and Zurich Insurance plc are authorised and regulated by the Financial Services Authority.

* Full details of Volkswagen warranties are available from your authorised Volkswagen Van Centre or Van Service Centre.

** All mileages are approximate as the system uses kilometres as the distance measure. Please consult your authorised Volkswagen Van Centre or Van Service Centre for full details.

† Finance packages can be provided by Volkswagen Finance, which is a trading name of Volkswagen Financial Services (UK) Limited. Terms and conditions apply to the products listed above.

Please note: Some of the vehicles shown are fitted with optional equipment at extra charge. All data given and specifications are in accordance with information available at the time of going to print and are subject to change without notice. Vehicles not in current UK stock and customer order vehicles may take a number of weeks for delivery. Certain combinations of vehicle specifications and factory fitted extras are not compatible and therefore all orders received are subject to confirmation. Please check details and availability with an authorised Volkswagen Van Centre at the time of ordering. The brand name Caddy is used with the kind approval of 'Caddie S.A., France'.

Volkswagen Original Parts®.

When you fit replacement parts to your vehicle, you need to know that they'll stand the test of time. Volkswagen Original Parts® are constructed to the highest standards, are cheaper than you might think and are widely available from Volkswagen Group's massive national distribution centre.

Options and accessories.

We know that no two businesses are the same. To this end, we have developed an extensive range of factory fitted, as well as Van Centre fitted accessories, so that your van can be enhanced with your own requirements in mind.

Volkswagen Assured Used Commercial Vehicles.

An increasing number of Volkswagen Van Centres are able to offer total peace of mind when purchasing a used van. You can rest in the confidence that every Volkswagen Assured Used Commercial Vehicle has been subjected to a comprehensive range of specialist checks that make them as safe a choice as a new Volkswagen van.

Volkswagen Van Rental.

Many Volkswagen Van Centres offer a cost-effective van rental service. It comes with the assurance that every van is late model, low mileage and presented in a high quality condition that reflects your business operation. Long-term business rental is also available. For more information on Volkswagen Van Rental, call **0845 602 4351**.

Volkswagen Roadside Assistance.

Every new Volkswagen purchased benefits from an unlimited mileage, comprehensive recovery and assistance package across the UK and Europe for a full three years, operating 24 hours a day, 365 days a year. Fully trained technicians are able to diagnose and repair most problems at the roadside, using Volkswagen equipment and parts. For more information ask your nearest Van Centre for a Volkswagen Roadside Assistance handbook.

Build your van.

		Basic retail excluding VAT £†	VAT £†	Total retail including VAT £†
Vehicle				
OTR package				
Factory fitted options				
Van centre fitted accessories				
Other costs				
Paint colour				
Upholstery				
Total				
Financial options	<input type="checkbox"/> Please inform me of my funding and finance options. <input type="checkbox"/> Please can I have details on fixed monthly price servicing.			

† Calculated at 15% on all products.

Glossary.

ABS Anti-lock Braking System.

It can be very challenging to stop a van quickly on a slippery road. ABS helps take a lot of the effort and stress out of a situation. In fact, even an average driver can stop more effectively with ABS than a professional driver without.

The theory is simple, a wheel that's skidding has less traction than a wheel that is not. For example, if you try to pull away too quickly on ice your wheels spin, meaning no traction. Simply, ABS prevents the wheels from skidding whilst you slow down, which means you slow faster and are able to steer while you come to a stop.

EDL Electronic Differential Lock.

Electronic Differential Lock uses the ABS sensors at driven wheels to determine if one of the wheels is spinning faster than the others. It uses the ABS system to momentarily apply braking to balance out the traction to the driven wheels. Front wheel drive vehicles typically have the most recognisable feel, as they make the typical ABS type pulsating sound when activated during wheel spin.

ESP Electronic Stabilisation Programme.

When the vehicle is driving in situations close to its limit ESP makes it easier to control, providing greater directional stability. By applying the brakes on individual wheels it generates forces that help to keep the vehicle moving in the right direction. The system is permanently active and utilises the ABS, EBD, EDL and TCS safety systems. However, the system cannot override the physical limits of the vehicle. If the driver pushes the vehicle beyond its limits ESP will not prevent an accident. On Crafter models, the ESP sensor takes into account any load on board and adjusts its response accordingly.

ARP Active Rollover Protection.

As part of the ESP system, ARP recognises an impending rollover and rapidly applies braking to selective wheels to resist the occurrence of rollover. Especially useful on a vehicle with a high centre of gravity such as a van. ARP detects excessive lateral force, for example driving too fast into a corner, which may result in a rollover.

TCS Traction Control System.

Traction control helps limit tyre slip on slippery surfaces while accelerating, thus helping the driver have greater control. Using sensors at each wheel, the system recognises when traction has been lost and it momentarily applies braking to that wheel to regain the traction.

Traction control does not have the ability to increase traction; it just attempts to prevent a vehicle's wheels from spinning. In some vehicles, TCS is also known as ASR.

EBA Electronic Brake Assist.

The Electronic Brake Assist system helps to shorten stopping distances, especially when fully laden. In an emergency when full brake pressure is required, a sensor recognises this and uses a hydraulic booster to aid the driver.

EBD Electronic Brakeforce Distribution.

EBD helps prevent the rear-end from breaking away under heavy braking by ensuring maximum braking performance at both the front and rear wheels. Brake 'fading', as a result of overheating, is also counteracted.

DPF Diesel Particulate Filter.

A diesel particulate filter is a system for removing particulates from diesel exhausts and is a major step forward in the reduction of particulate contaminants in the environment.

EBC Engine Braking Control.

This system prevents the driven wheels from locking due to the engine braking effect when the accelerator pedal is released suddenly or when the vehicle is braked with a gear engaged.

Passive safety.

Passive safety refers measures that help protect the occupants against injury or help reduce injury severity in the event of an accident. Passive safety measures include the safety belt system, the airbags*, the rigid occupant cell and the crumple zones at the front of the vehicle. Safety features built-in to the body, front and rear, help dissipate most of the impact energy. All help provide excellent all-around protection.

* Airbags are supplemental restraints only and will not deploy under all accident circumstances. Always use seat belts and child seating appropriate for their size and age. All child seating must meet the current legislation.

Dedicated Van Centre network.

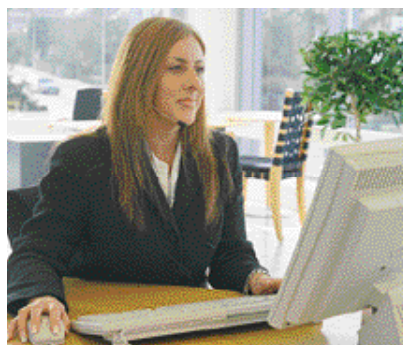

Our network of Van Centres is spread throughout the UK, and forms the backbone of everything we do for you. Week in, week out, our Van Centres provide vital technical support and practical backup for everything that relates to Volkswagen vans. This reservoir of knowledge and array of technical ability is there for you when you need it.

We're constantly improving and extending our range of services, and improving opening hours to meet

your needs. After all, you need your vehicle serviced at the most convenient time, and we understand that down time equals lost income.

And don't forget, having read through this brochure, if you still aren't sure which vehicle is the right one, then your nearest Van Centre staff will be pleased to help.

www.vwvancentres.co.uk

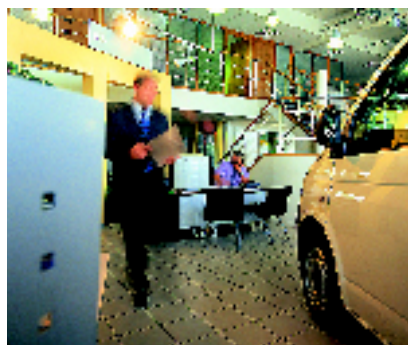

Panel vans

May 2009

**This brochure supersedes all previous publications.
CVW227PVAN**

www.volkswagen-vans.co.uk