



**THE NEW MINI COUPÉ.**

# CONTENTS.

## MINI PRESENTS: ADVENTURES WITH THE MINI COUPÉ.

<b>MODELS</b>	<b>14</b>
<b>SAFETY</b>	<b>16</b>
<b>COLOURS AND UPHOLSTERY</b>	<b>18</b>
<b>EXTERIOR DESIGN AND WHEELS</b>	<b>22</b>
<b>INTERIOR DESIGN</b>	<b>26</b>
<b>MUSIC, COMMUNICATIONS AND TECHNOLOGY</b>	<b>28</b>
<b>PERFORMANCE</b>	<b>30</b>
<b>JOHN COOPER WORKS</b>	<b>32</b>
<b>ACCESSORIES</b>	<b>36</b>
<b>MINI DATA.</b>	
Technical data	<b>38</b>
Dimensional drawings	<b>39</b>

[MINI.CO.UK/CONFIGURATOR](http://MINI.CO.UK/CONFIGURATOR)

This link will take you straight to the online MINI Configurator.

MINI.co.uk



# THE WRONG PART OF TOWN NEVER FELT SO RIGHT.

Most people would turn weak at the knees, but for adventurous spirits, it's a sight to make the spirits soar: the new MINI Coupé. Built for pure driving excitement.







**TWO SEATS, 143 HP –  
AND 365 DAYS OF  
ADVENTURE A YEAR.**

Surprised by the crowds? You shouldn't be. The new MINI Cooper SD Coupé is one stunning looker. You'll just have to get used to the attention.

**YOU DON'T HAVE TO  
TAKE EVERYTHING  
WITH YOU. BUT IT'S  
GOOD TO KNOW  
YOU CAN.**



An invitation you can't refuse? Then don't. In the new MINI Coupé, you can grab any opportunities that come your way. With 280 litres of luggage space and a through-load function for access to the passenger compartment, you can go wherever takes your fancy.



**CLEARED  
FOR  
TAKE-OFF.**



Sick of the city? Then get out of town. When the speed exceeds 50 mph the active rear spoiler automatically pops up. Making the new MINI Coupé the only high-flyer that sticks to the ground like glue. The active rear spoiler can also be operated manually from within the vehicle.





# **BORED OF LEFT AND RIGHT? THEN TRY A WHOLE NEW DIRECTION.**

The new MINI Coupé is licensed to thrill. Dynamic styling and contrasting sport stripes ensure it makes an impact from any angle. So sit back and admire the view.





**GET AWAY FROM  
BACK-SEAT DRIVERS.**





- 1 DESIGN: DYNAMIC.** The heavily slanted front windscreen and low roof create a sweeping profile. Together with the sport stripes and active rear spoiler, this makes for a look which isn't just elegant, but exudes speed.
- 2 ENGINE: POWERFUL.** The four-cylinder twin-scroll turbo engine fitted to the MINI Cooper S Coupé was voted Best Engine Of The Year<sup>1</sup> in its class five years in a row. This state-of-the-art power plant is just one of the reasons why this is such a pulse-racing sports car.
- 3 RESPONSES: INSTANTANEOUS.** Stiff bodywork, a low centre of gravity and incredibly direct steering add up to superb acceleration, great traction, and more wow factor.
- 4 AERODYNAMICS: BREATHTAKING.** The streamlined front end, low wind resistance and automatically extending active rear spoiler deliver more grip and enhanced safety.
- 5 MINIMALISM<sup>2</sup>: INNOVATIVE.** Shift Point Display, Automatic Start-Stop Function, Brake Energy Regeneration and fully variable valve timing deliver maximum fun with minimum fuel consumption. For example, the new MINI Cooper SD Coupé manages 65.7 mpg on the combined cycle whilst also offering a 0 to 62 mph sprint time of just 7.9 seconds.

<sup>1</sup> For more information about the "Best Engine Of The Year" award, visit [www.ukipme.com/engineoftheyear/](http://www.ukipme.com/engineoftheyear/)

<sup>2</sup> MINIMALISM features may vary depending on the optional equipment fitted. Please contact your MINI Dealer for further information.

# READY TO ROCK.



## MINI COOPER COUPÉ.

First impressions count: on the new MINI Cooper Coupé, the radiator grille slats are chrome-plated, the exterior mirrors are finished in the same contrast colour as the roof, and the side scuttles with built-in white direction indicator lights are in black. Chrome elements such as the exhaust tailpipe and tailgate handle add emphasis to the powerful rear end of the car.

## MINI COOPER S COUPÉ.

The new MINI Cooper S Coupé is not afraid to show what it's got, with a sporty hexagon-look radiator grille, a central air intake in the bonnet, and a front bumper featuring two separate air ducts to cool the brakes. At the rear, the exhaust system has two stylish chrome-plated tailpipes.

## MINI COOPER SD COUPÉ.

With 305 Nm available at just 1,750 rpm, the new MINI Cooper SD Coupé is the sports coupé that walks the torque. Visually it looks just as dynamic as the new MINI Cooper S Coupé: the side scuttles with white direction indicator lights are chrome-plated, and bear the red MINI Cooper S emblem.

# MODELS.

---



# SAFETY.

---

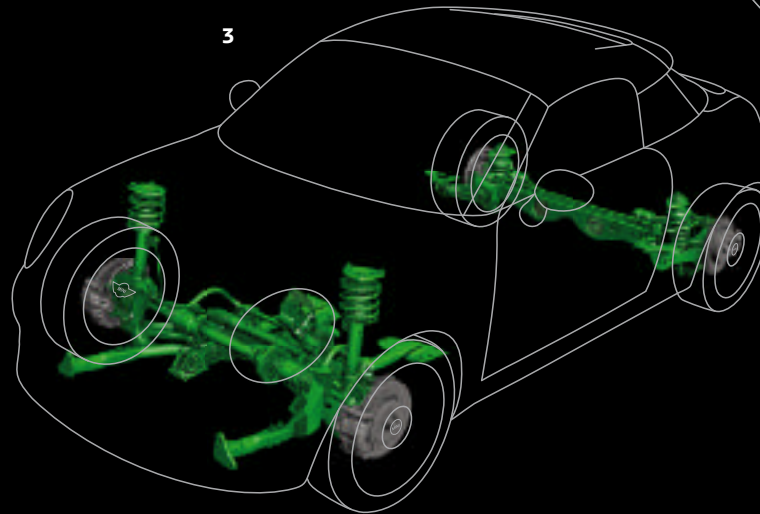
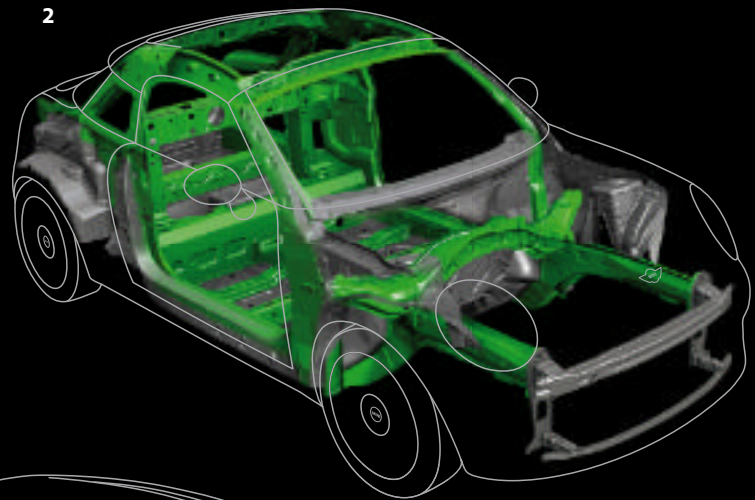
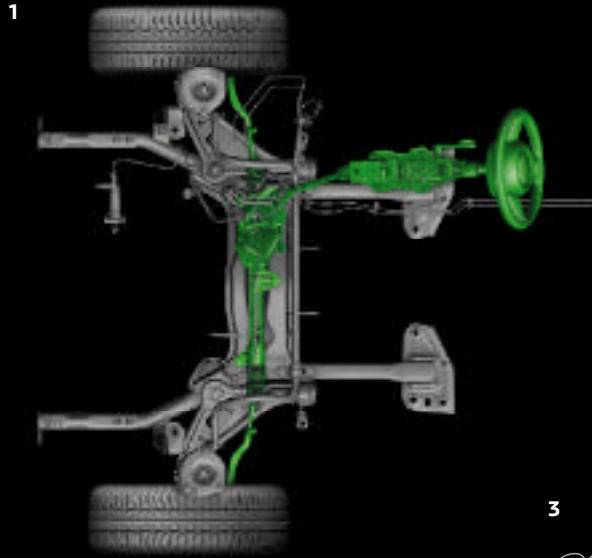

**1. Rack-and-pinion steering.** Electric power-assist ensures outstanding steering responses, with the driver receiving precise and involving feedback. The steering is lighter at low speeds and stiffer at high speeds, for ease of control at all times. For maximum comfort, it is only 2.4 turns from lock to lock.

**2. Body.** The body of the new MINI Coupé has been reinforced at strategic points, guaranteeing extreme torsional rigidity for an exceedingly robust passenger compartment. This enables the new MINI Coupé to combine speed, safety and agile responses even in adverse conditions.

**3. Suspension.** The combination of a single-link spring-strut front axle and a multi-link rear axle with wide track and a low centre of gravity results in the unmistakable MINI feeling: stable, agile, with optimum cornering ability at all speeds, plus superb traction and outstanding safety.



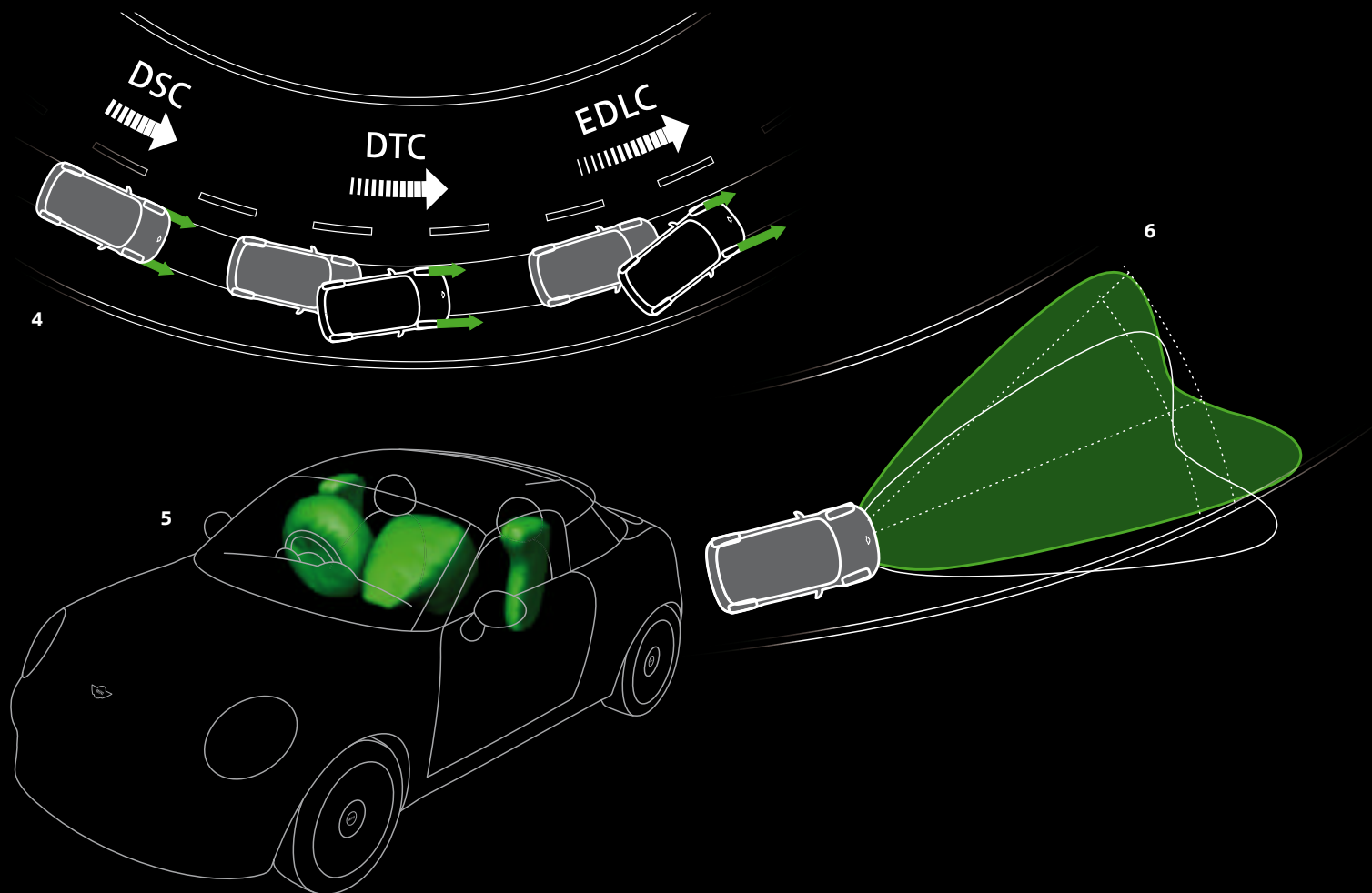

4. Fitted as standard, **Dynamic Stability Control (DSC)** counteracts loss of grip by intervening in the engine management and applying braking force to individual wheels at the front and rear as necessary. Should the inner wheel lose too much traction, the optional **Dynamic Traction Control (DTC)** with Electronic Differential Lock Control (EDLC) will apply braking to it, ensuring the car maintains forward momentum through corners and on surfaces with variable levels of grip. At the same time, DTC also enables more torque to be applied to the outer wheel. This option is standard on the new MINI John Cooper Works Coupé.

5. The new MINI Coupé is fitted as standard with **four airbags**: driver and front passenger airbags protect the head and upper body in the event of a head-on collision, while two additional head/thorax airbags are primarily designed to reduce the risk of injuries to the head, chest and abdominal areas from side impacts.

6. **Adaptive Headlights**. This option, featuring automatic headlight beam-throw control, ensures optimum illumination whether driving in city or country, and allows drivers to see further ahead on the motorway. Sensors measure the steering angle, rotational speed of the wheels and vehicle speed, and electric motors then adjust the position of the light beam accordingly. Only available in conjunction with Vision Pack.

# COLOURS AND UPHOLSTERY.

Let MINI add some colour to your life: the new MINI Coupé is available in a choice of metallic and non-metallic paint finishes. In total there are nine exterior colours and three roof colours, which can be combined in pretty much any way you want. With a total of around 250 combinations of body colour, roof colour, exterior mirror caps and wheels on offer, your MINI will be uniquely yours.

[MINI.CO.UK/CONFIGURATOR](http://MINI.CO.UK/CONFIGURATOR)

## ROOF COLOURS FOR MINI COUPÉ.



Contrast roof in Jet Black

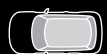

Contrast roof in Pure Silver



Contrast roof in Chili Red  
(Only for MINI John Cooper Works Coupé)

## NON-METALLIC COLOURS.

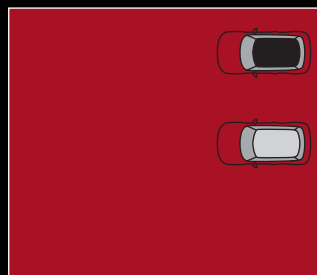

851  
Chili Red

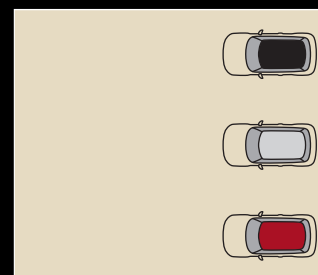

850  
Pepper White

## METALLIC COLOURS.

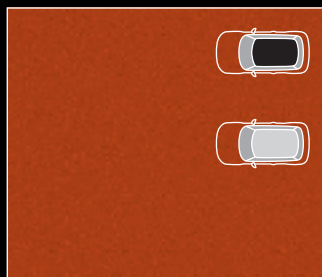

B23  
Spice Orange Metallic

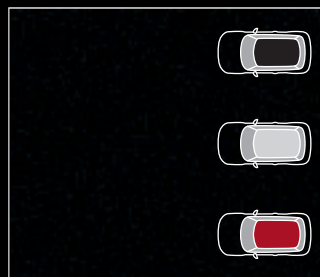

A94  
Midnight Black Metallic<sup>1</sup>

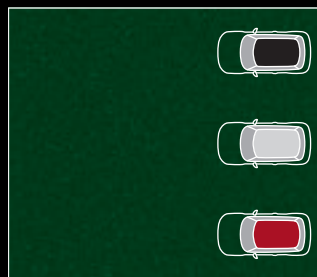

B22  
British Racing Green II Metallic



B24  
Eclipse Grey Metallic

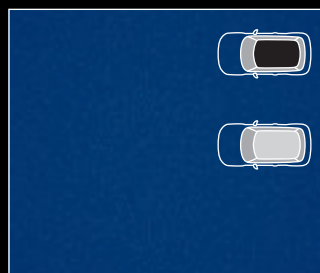

A63  
Lightning Blue Metallic

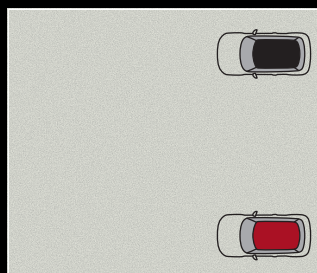

A62  
White Silver Metallic

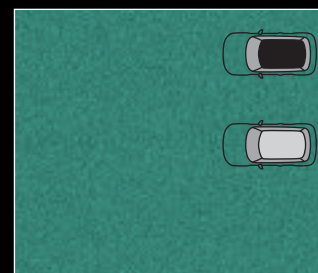

B46  
MINI Yours  
Laguna Green Metallic<sup>2</sup>

As standard on ■ MINI Cooper Coupé ■ MINI Cooper SD Coupé  
■ MINI Cooper S Coupé ■ MINI John Cooper Works Coupé

Optional on □ MINI Cooper Coupé □ MINI Cooper SD Coupé  
□ MINI Cooper S Coupé □ MINI John Cooper Works Coupé



4C1  
Carbon Black



4C3  
Satellite Grey

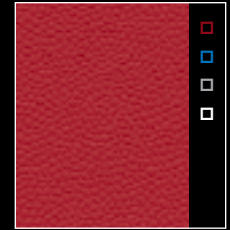

4BA  
Rooster Red



4CN  
Toffee



4C2  
Polar Beige

## COLOUR LINE.

It's all about the right combinations: the Colour Line is central to the distinctive interior of the new MINI Coupé. The armrest in the door and the knee roll are available in a choice of five Colour Line colours, and if you choose the Polar Beige option, there is also the option of a Polar Beige trim for the interior door insert. All five Colour Line colours can be paired with seven different interior surface finishes. Time to start thinking about your perfect match.

## INTERIOR SURFACES.

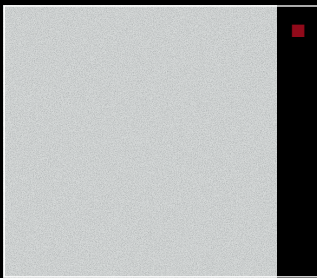

Fine White Silver

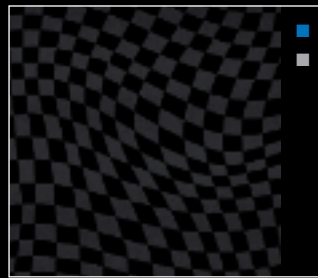

Black Chequered

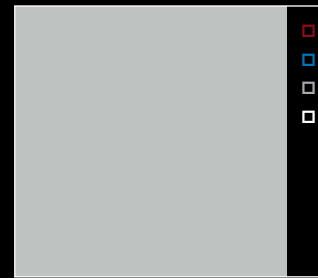

4BC  
Fluid Silver

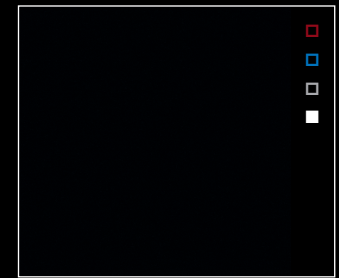

4BD  
Piano Black

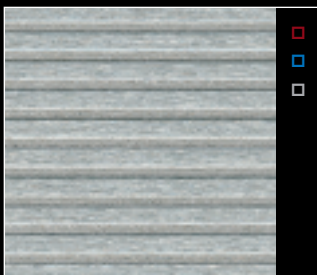

4DA  
Striped Alloy

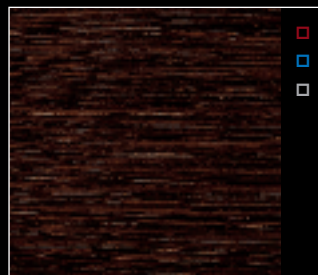

4BE  
English Oak



4CY  
Chili Red

<sup>1</sup> Where the exterior colour is Midnight Black Metallic, the contrast roof in Jet Black is replaced by a roof in body colour.

<sup>2</sup> MINI Yours design programme expected to be available from end of third quarter of 2011.

# COLOURS AND UPHOLSTERY.

## PUNCH LEATHER. CROSS CHECK. AND THEN A PIT STOP.

[MINI.CO.UK/CONFIGURATOR](https://www.mini.co.uk/configurator)

Sit back and think carefully. It's an important decision: a good sports car needs the right seats. And for the new MINI Coupé, there is a choice of sporty upholsteries in cloth, leather or a combination of the two. So get mixing and matching.

### CLOTH STANDARD SEAT

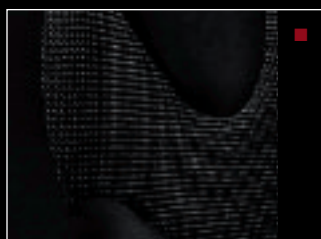

Cosmos cloth<sup>1</sup>  
APE1 Carbon Black

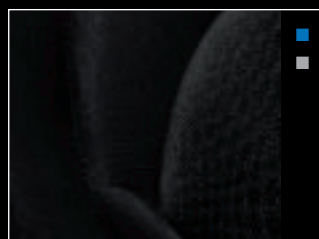

Chequered cloth<sup>2</sup>  
ATE1 Carbon Black

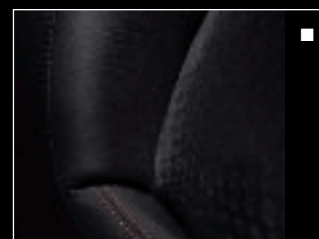

Chequered cloth<sup>2,4</sup>  
John Cooper Works Carbon Black

### RAY CLOTH/LEATHER SPORT SEAT

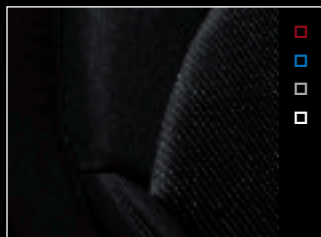

Ray cloth/leather<sup>2</sup>  
FKE1 Carbon Black

### CROSS CHECK CLOTH/LEATHER SPORT SEAT

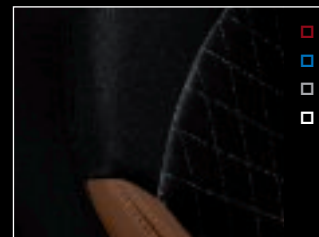

Cross Check cloth/leather<sup>2</sup>  
FTDT Toffee

<sup>1</sup> Only for standard seat.

<sup>2</sup> Only for sport seat.

<sup>3</sup> Leather upholstery includes seats (base and backrest), and front and rear headrests.

As standard on ■ MINI Cooper Coupé ■ MINI Cooper SD Coupé  
■ MINI Cooper S Coupé ■ MINI John Cooper Works Coupé

Optional on □ MINI Cooper Coupé □ MINI Cooper SD Coupé  
□ MINI Cooper S Coupé □ MINI John Cooper Works Coupé

**PUNCH LEATHER  
SPORT SEAT**

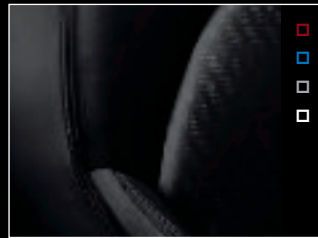

Punch leather<sup>2,3</sup>  
T8FP Carbon Black/Beige

**GRAVITY LEATHER  
SPORT SEAT**



Gravity leather<sup>2,3</sup>  
T6GW Polar Beige

**LOUNGE LEATHER  
SPORT SEAT**



Lounge leather<sup>2,3</sup>  
T9DT Toffee

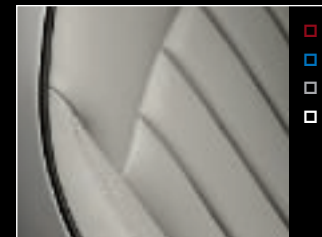

Lounge leather<sup>2,3</sup>  
T9GK Satellite Grey

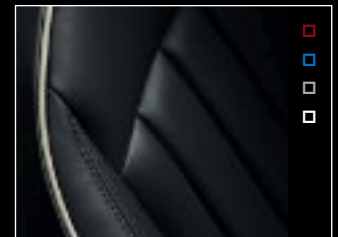

Lounge leather<sup>2,3</sup>  
T9E1 Carbon Black

**LOUNGE LEATHER  
SPORT SEAT**

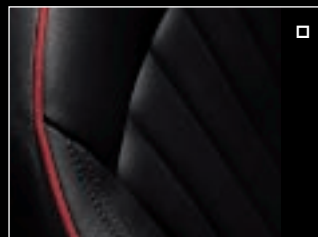

Lounge leather<sup>2,3,4</sup>  
T9IN Carbon Black  
Championship Red

**MINI YOURS  
LOUNGE LEATHER  
SPORT SEAT**



MINI Yours Soda Lounge leather<sup>2,3,5</sup>  
TZGK Satellite Grey

<sup>4</sup> Only available on MINI John Cooper Works Coupé.

<sup>5</sup> MINI Yours design programme expected to be available from end of third quarter of 2011.

# EXTERIOR DESIGN AND WHEELS.

## WHEELS OF FIRE.

There are no fewer than 13 different wheel and tyre combinations to choose from, including the MINI Yours Twin Blade Spoke design. So you can give your new MINI Coupé its own distinctive look. Burn, baby, burn!

[MINI.CO.UK/CONFIGURATOR](http://MINI.CO.UK/CONFIGURATOR)



1. Cross Spoke CHALLENGE, silver



2. 7-Hole, silver



3. 5-Star Twin Spoke, silver



4. 8-Star Rib Spoke, silver

1. Cross Spoke CHALLENGE alloy wheels in silver. Size: 7 J x 17 inches, tyres 205/45 R17.
2. 7-Hole alloy wheels in silver. Size: 5.5 J x 15 inches, tyres 175/65 R15.
3. 5-Star Twin Spoke alloy wheels in silver. Size: 5.5 J x 15 inches, tyres 175/65 R15.
4. 8-Star Rib Spoke alloy wheels in silver. Size: 6.5 J x 16 inches, tyres 195/55 R16.

As standard on  MINI Cooper Coupé  MINI Cooper SD Coupé  
 MINI Cooper S Coupé  MINI John Cooper Works Coupé

Optional on  MINI Cooper Coupé  MINI Cooper SD Coupé  
 MINI Cooper S Coupé  MINI John Cooper Works Coupé



5. 4-Hole Circular Spoke, silver



6. 6-Star Twin Spoke, silver<sup>1</sup>



7. Conical Spoke, silver<sup>1</sup>



8. 5-Star Pace Spoke, silver



9. Web Spoke, silver



10. Web Spoke Two-tone black



11. Infinite Stream Spoke, silver



12. Black Star Bullet, matt black



13. MINI Yours Twin Blade Spoke, silver

5. 4-Hole Circular Spoke alloy wheels in silver. Size: 6.5 J x 16 inches, tyres 195/55 R16.

6. 6-Star Twin Spoke alloy wheels in silver. Size: 6.5 J x 16 inches, tyres 195/55 R16.

7. Conical Spoke alloy wheels in silver. Size: 7 J x 17 inches, tyres 205/45 R17.

8. 5-Star Pace Spoke alloy wheels in silver. Size: 7 J x 17 inches, tyres 205/45 R17.

9. Web Spoke alloy wheels in silver. Size: 7 J x 17 inches, tyres 205/45 R17.

10. Web Spoke alloy wheels in two-tone black. Size: 7 J x 17 inches, tyres 205/45 R17.

11. Infinite Stream Spoke alloy wheels in silver. Size: 7 J x 17 inches, tyres 205/45 R17.

12. Black Star Bullet alloy wheels in matt black. Size: 7 J x 17 inches, tyres 205/45 R17.

13. MINI Yours Twin Blade Spoke alloy wheels in silver. Size: 7 J x 17 inches, tyres 205/45 R17.

<sup>1</sup> Also available in Black.

In addition to the factory-fitted wheel sets, certain wheel designs are also available as part of the Winter Wheel and Tyre Programme. Please contact your MINI Dealer for details.

# SPORT'N'STRIPES.



## SPORT STRIPES IN BLACK

- Even when it's not moving the new MINI Coupé
- looks quick. Where the roof is in black, the
- sport stripes on the bonnet and rear are in
- the same colour. The roof stripes are in body
- colour, making a striking contrast.

## SPORT STRIPES IN RED

- Sport stripes in red are exclusive to the new
- MINI John Cooper Works Coupé. They are
- combined with a red roof, and the stripes on
- this are in body colour. They say stripes are
- slimming, but these particular ones are more
- quickening.

## SPORT STRIPES IN SILVER

- Sport stripes in silver give the new MINI Coupé
- a particularly elegant look. Here too, the roof is
- in the same colour as the stripes on the bonnet
- and rear of the car, while the stripes on the roof
- are in body colour. Get it? Good!



As standard on  MINI Cooper Coupé  MINI Cooper SD Coupé  
 MINI Cooper S Coupé  MINI John Cooper Works Coupé

Optional on  MINI Cooper Coupé  MINI Cooper SD Coupé  
 MINI Cooper S Coupé  MINI John Cooper Works Coupé



1. Chrome Line Exterior



2. Chrome Line Exterior



3. Chrome Line Exterior



4. Chrome Line Exterior



5. Exterior mirror caps in chrome/body colour



6. Darkened rear glass

1–4. Add some sparkle, with the **Chrome Line Exterior**. For the new MINI Cooper Coupé this includes chrome edging for the lower front grille and front fog lights. At the rear, the central fog light features chrome edging. The new MINI Cooper S/SD Coupé has even more of a good thing, featuring chrome edging for the brake-cooling front air ducts, rear fog lights and a chrome tailgate handle.

5. The **exterior mirror caps** come as standard in the same contrast colour as the roof on all new MINI Coupé models. There is also the option of a body-colour or chrome finish. It's a small detail that makes a big difference.

6. A cool feature: the side windows and rear windscreen are tinted a darker colour. Even cooler: the **darkened rear glass** reduces the build-up of heat in the interior of the car caused by strong sunlight, so the driver can stay cool, calm and collected.

[MINI.CO.UK/CONFIGURATOR](http://MINI.CO.UK/CONFIGURATOR)



# INTERIOR DESIGN.

## ROOM TO SPARE.

In you get: the new MINI Coupé has 280 litres of luggage capacity – enough to accommodate all the equipment you need for your adventures in the urban jungle.



1. Luggage compartment



2. Through-loading function



3. Interior lights pack

**1. Luggage compartment.** Easy does it! The wide-opening tailgate makes loading and unloading simple. Under the rear section of the load-compartment floor there is an area where precious items can be safely stowed. And thanks to the optional 12-volt socket in the luggage compartment (available as part of the storage compartment pack), you can make sure your electronic devices never run out of juice.

**2. Get in!** The new MINI Coupé has a **through-loading function** with a lockable hatch. This measures 360 x 200 millimetres, making it big enough for a guitar, surfboard or anything else you need on your adventures. Even better, it can be opened from the driver or passenger seat, so you can pop small items in the boot without getting out of the car.

**3. Prepare to be dazzled,** with the **interior lights pack**: in addition to the standard interior lighting, this also includes an extra reading light in the headliner, plus footwell and exterior floor-level lights. Particularly striking is the ambient lighting for the door handles, door storage compartments and instrument panel backlight, which can cycle steplessly through all the colours of the spectrum.

As standard on ■ MINI Cooper Coupé ■ MINI Cooper SD Coupé  
■ MINI Cooper S Coupé ■ MINI John Cooper Works Coupé

Optional on □ MINI Cooper Coupé □ MINI Cooper SD Coupé  
□ MINI Cooper S Coupé □ MINI John Cooper Works Coupé



26  
27

4. Interior with MINI Yours leather-upholstered instrument panel in Black/Polar Beige and interior surfaces in Piano Black.<sup>1</sup>



5. Headliner in Anthracite



6. Chrome Line Interior (belt ring)

**4. Interior.** Finally a car where you can focus on the things that really matter – like enjoying the drive. A unique feature is the optional leather-upholstered instrument panel, the upper section of which is upholstered in black leather and the lower section is available in a choice of Polar Beige or Satellite Grey.

**5. Headliner in Anthracite.** The headlining of the passenger compartment in the new MINI Coupé comes as standard in this dark shade, and incorporates recesses in the same elliptical shape as the door trims. The result is more headroom and an

uplifting sports-car feel. The controls for the interior lighting, the optional interior lights pack and the active rear spoiler are located above the rear-view mirror.

**6. As outside, so inside: with the Chrome Line Interior,** the speedometer, revolution counter, air vents, gear lever base and handbrake grip are all trimmed in chrome. And if that's not enough, the door handles, loudspeakers in the door and cupholders are also chrome-plated, while the belt rings have a matt chrome finish.

<sup>1</sup> MINI Yours design programme expected to be available from end of third quarter of 2011.

# MUSIC, COMMUNICATIONS AND TECHNOLOGY.



## THE FASTEST CLUB IN TOWN.

Its name is the Radio MINI Visual BOOST, but in reality it's actually a highly sophisticated optional entertainment system, with a 6.5-inch display, MINI joystick, Bluetooth hands-free functionality, aux-in port and USB audio/video interface. If that's not enough, with the optional MINI Connected service, the Radio MINI Visual BOOST can also receive Internet radio stations from all over the world, find points of interest using Google™ Local Search, get live RSS news feeds, and let you post updates on your current destination and ETA on Facebook and Twitter. With the Driving Excitement app<sup>2</sup>, nothing can stop you from taking sports-style driving to the max. And if you opt for the harman/kardon hi-fi system, it also comes with ten built-in loudspeakers, so you can enjoy all your favourite music in sensational sound quality.

<sup>1</sup> Availability and range of features are dependent on the other equipment fitted, and may vary from country to country. Range and design of MINI Connected functions subject to change without notice. Broadband mobile Internet access required. Costs resulting from this (e.g. data roaming) will be payable as specified in the contract with your network provider. MINI Connected app available free of charge from the device manufacturer's app store (subject to national restrictions). Updates available free of charge, but version upgrades may be chargeable. For more information about device compatibility and the functions contained in MINI Connected, visit [MINI.com/connectivity](http://MINI.com/connectivity)

<sup>2</sup> Expected to be available from fourth quarter of 2011.

As standard on  MINI Cooper Coupé  MINI Cooper SD Coupé  
 MINI Cooper S Coupé  MINI John Cooper Works Coupé

Optional on  MINI Cooper Coupé  MINI Cooper SD Coupé  
 MINI Cooper S Coupé  MINI John Cooper Works Coupé



1. MINI Connected<sup>1</sup> with Driving Excitement app<sup>2</sup>



2. MINI Navigation system



3. harman/kardon hi-fi system



4. Full Bluetooth telephone preparation with USB audio interface



5. Bi-xenon headlights



6. Adaptive Headlights

1. **MINI Connected<sup>1</sup> with Driving Excitement app<sup>2</sup>**: this new function includes a digital sport display, and analyses how sporty and accurate your driving style is.<sup>2</sup> MINI Connected lets you access online services such as Facebook, Twitter, Google™ Local Search and Google™ Send To Car on the central display. For more information visit [MINI.com/connectivity](http://MINI.com/connectivity)

2. The **MINI Navigation system** ensures you'll never lose your way. With its pre-installed maps, it will guide the new MINI Coupé to even the most obscure addresses. It includes day and night modes, a search function for points of interest, TMC reception via a double tuner, a GPS aerial and support for updates via the USB interface.

3. **harman/kardon hi-fi system**: including a total of ten high-performance speakers seamlessly incorporated into the interior of the car, with a maximum output of 480 watts.

4. The full **Bluetooth telephone preparation with USB audio interface** option also includes a centre armrest and a three-spoke sport leather steering wheel with multifunction option and cruise control. Bluetooth-enabled mobile phones can be plugged into the armrest via a snap-in adapter (available separately), recharging their batteries and connecting them to the vehicle's external aerial for improved reception.

5. **Bi-xenon headlights** for dipped and full-beam settings, with headlight beam-throw control and headlight washer system, offer particularly powerful illumination.

6. The optional **Adaptive headlights**, featuring automatic headlight beam-throw control, ensure optimum illumination whether driving in city or country, and allow drivers to see further ahead on the motorway. Sensors measure the steering angle, rate of turn and vehicle speed, and electric motors then adjust the position of the light beam accordingly to suit the speed and direction of the car.

## PERFORMANCE.

---

# MAKE A STATEMENT AT THE TOUCH OF A BUTTON.



Could it be magic? The **active rear spoiler** of the new MINI Coupé automatically extends at 50 mph increasing downforce on the rear axle for greater stability when cornering and travelling at high speeds. When the speed falls below 37 mph, it then retracts again. You can also extend it manually if you need to clean it – or if you just want to show off.



If you want to push your new MINI Coupé harder, first you've got to push the **sport button**. This makes steering and throttle responses more immediate, for an even more involving driving experience. In addition, on models fitted with automatic transmission, the sport button shortens gearshift times.

As standard on ■ MINI Cooper Coupé ■ MINI Cooper SD Coupé  
■ MINI Cooper S Coupé ■ MINI John Cooper Works Coupé

Optional on □ MINI Cooper Coupé □ MINI Cooper SD Coupé  
□ MINI Cooper S Coupé □ MINI John Cooper Works Coupé

# MINI SPORT PACK.



The **MINI Sport Pack** is a fitting tribute to the car's racing pedigree. The aerodynamic package comprises front and rear aprons, plus side skirts with track-style air intakes that emphasise the car's character. The Cross Spoke CHALLENGE alloy wheels complete the aggressive look.



A statement of intent: the 17-inch Cross Spoke CHALLENGE alloy wheels in silver.



The MINI Sport Pack includes the John Cooper Works aerodynamic kit with a striking rear bumper.



With its Red gearshift emblem and contrast stitching in Chili Red, the short-throw gear lever for the manual transmission looks almost as good as it feels to use.



A firm grip on the situation: the three-spoke sport leather steering wheel with contrast stitching in Chili Red.<sup>1</sup>

<sup>1</sup> Chili Red stitching only available in combination with manual transmission.

For further details about the MINI Sport Pack please refer to the MINI Coupé Price List.

# THE NEW, 211-HORSEPOWER MINI JOHN COOPER WORKS.

The new MINI John Cooper Works Coupé was made for three things: driving, driving and driving. Anyone who's experienced its 211 horsepower (155 kW) and acceleration from 0 to 62 mph in 6.4 seconds won't need any more convincing. The six-speed manual transmission, sport button and overboost function that increases its maximum torque from 260 to 280 Nm are all just an added bonus. Quite a big bonus though.







# FAST, EFFECTIVE RELIEF. THE NEW MINI JOHN COOPER WORKS COUPÉ



The red roof is an option exclusive to the new MINI John Cooper Works. The car's 211-horsepower output ensures exhilarating performance. The engine, equipment levels and styling all combine to make it the most thrilling MINI there is. Not to mention the quickest.

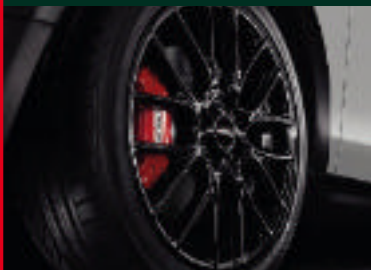

A strong impression: the 17-inch Cross Spoke CHALLENGE alloy wheels in black or silver. Stopping power: the red brake calipers.



The sport exhaust with twin tailpipes is the source of that unmistakable John Cooper Works sound.



The imposing side skirts in body colour feature sports-style air intakes.



Built to perform: the John Cooper Works engine is guaranteed to set the pulse racing.



Take a look inside: an optional Chili Red finish is available for the interior surfaces and door ellipses. Combined with Red contrast stitching for the gearshift and handbrake gaiter, and instruments with Anthracite dials, it adds up to the raciest MINI on the road.



A turn for the better: the three-spoke multi-function sport steering wheel in Alcantara. Putting a figure on excitement: the stylish speedometer with Anthracite dial.

Performance in the palm of your hand: the precise short-throw six-speed manual gearbox boasts an eye-catching gearshift emblem in Chili Red, plus contrast stitching in the same colour on the gaiter.

One glance at the optional leather dashboard with knee roll and upper surface finished in anthracite Dinamica, and you know you're sitting in a true sports coupé.

[MINI.CO.UK/CONFIGURATOR](http://MINI.CO.UK/CONFIGURATOR)



# GENUINE MINI ACCESSORIES.



New MINI Cooper Coupé with Genuine MINI Accessories



Side scuttles with Union Jack design



Multi Spoke style 108 alloy wheels in matt black



Snap-in adapter with USB interface

**KEEP IT MINI.** Make the best even better: **Genuine MINI Accessories**<sup>1</sup> have been designed to fit perfectly with your new MINI Coupé in terms of both functionality and visual design. All products have successfully completed a rigorous testing process, so you can rest assured they will only enhance your MINI experience. To give your new MINI Coupé a distinctive look, there are striking alloy wheel designs, sporty additional headlights and eye-catching exterior mirror caps and rear-view mirror housings.

Inside, there are practical solutions like the rotatable holder for the MINI Portable Navigation System, and the snap-in adapter with USB interface for your mobile phone. There is also a carpeted shelf for the interior. And to help you make the most of your leisure time, there are clever transportation and luggage solutions like the fitted luggage compartment mat and the rear-mounted rack for two bicycles. Ready to roll?

# JOHN COOPER WORKS TUNING.



New MINI Cooper S Coupé with John Cooper Works Tuning



Cross Spoke R113 alloy wheels with Red Stripe



Additional instruments



Side scuttles



**KEEP IT WILD.** Looking for a genuine racetrack experience? Good. Because that's just what **John Cooper Works Tuning**<sup>1</sup> gives you. The John Cooper Works Tuning Kit boosts the output of the new MINI Cooper S Coupé to a mighty 197 hp, thanks to a special air filter and reprogrammed engine management software. A sports exhaust system with large tailpipes in chrome adds to the impression of power, and striking alloy wheels plus side scuttles, air intake and exterior mirror caps all

in clear lacquered Carbon complete the high-tech racing look. The eye-catching rear spoiler, meanwhile, is there to enhance aerodynamic performance. Inside the car too, John Cooper Works Tuning creates a real motorsport ambience, with details such as interior surfaces in Carbon, and additional instruments. So what are you waiting for?

<sup>1</sup>For more information, visit [MINI.co.uk/accessories](http://MINI.co.uk/accessories)

# TECHNICAL DATA.

ENGINE <sup>1,2</sup>		MINI COOPER COUPÉ	MINI COOPER S COUPÉ	MINI COOPER SD COUPÉ	MINI JOHN COOPER WORKS COUPÉ
Cylinders/layout/valves per cylinder		4/in-line/4	4/in-line/4	4/in-line/4	4/in-line/4
Displacement	cm <sup>3</sup>	1598	1598	1995	1598
Stroke/bore	mm	85.8/77.0	85.8/77.0	90.0/84.0	85.8/77.0
Max. output/max. revs	hp (kW)/rpm	122 (90)/6000	184 (135)/5500	143 (105)/4000	211 (155)/6000
Max. torque/revs	Nm/rpm	160/4250	240/1600–5000 (260/1700–4500) <sup>3</sup>	305/1750–2700	260/1850–5600 (280/2000–5100) <sup>3</sup>
Compression ratio/recommended fuel	:1	11.0/91–98 RON	10.5/91–98 RON	16.5/diesel	10/91–98 RON
<b>PERFORMANCE<sup>1</sup></b>					
Max. speed	mph km/h	127 [123] 204 [198]	143 [139] 230 [224]	134 [128] 216 [206]	149 240
Acceleration 0–62 mph (0–100 km/h)	sec.	9.0 [10.3]	6.9 [7.1]	7.9 [8.2]	6.4
Acceleration 50–75 mph (80–120 km/h) (4th/5th gear)	sec.	9.4/11.9	5.5/6.9	6.5/7.7	5.1/6.1
<b>FUEL CONSUMPTION<sup>1,2</sup></b>					
Urban	mpg l/100 km	40.9 [32.5] 6.9 [8.7]	38.7 [31.7] 7.3 [8.9]	55.4 [40.9] 5.1 [6.9]	30.1 9.4
Extra-urban	mpg l/100 km	61.4 [55.4] 4.6 [5.1]	56.5 [56.5] 5.0 [5.0]	72.4 [65.7] 3.9 [4.3]	48.7 5.8
Combined	mpg l/100 km	52.3 [44.1] 5.4 [6.4]	48.7 [44.1] 5.8 [6.4]	65.7 [53.3] 4.3 [5.3]	39.8 7.1
CO <sub>2</sub> emissions (combined)	g/km	127 [150]	136 [149]	114 [139]	165
Tank capacity, approx.	litres	40	50	40	50
Range	miles km	460 [388] 740 [625]	534 [485] 860 [780]	578 [469] 930 [755]	438 705
<b>WEIGHT<sup>1</sup>/LUGGAGE CAPACITY</b>					
Unladen weight (EU) <sup>4</sup>	kg	1165 [1210]	1240 [1265]	1250 [1270]	1240
Max. permitted weight	kg	1380 [1425]	1455 [1480]	1465 [1485]	1455
Max. permitted load	kg	290	290	290	290
Max. permitted axle load, front/rear	kg	820/590 [855/590]	870/605 [895/605]	890/600 [905/600]	865/610
Length/width (excluding door mirrors)/height	mm	3728/1683/1378	3734/1683/1384	3734/1683/1384	3758/1683/1385
Luggage capacity	litres	280	280	280	280
<b>WHEELS</b>					
Tyre dimensions, front/rear		175/65 R 15 84H	195/55 R 16 87V	195/55 R 16 87V	205/45 R 17 84W
Wheel dimensions, front/rear		5.5 J x 15 light-alloy	6.5 J x 16 light-alloy	6.5 J x 16 light-alloy	7 J x 17 light-alloy

<sup>1</sup> All figures relate to vehicles with the standard six-speed manual transmission. Figures in square brackets relate to vehicles with six-speed Automatic Transmission Steptronic.

<sup>2</sup> All MINI models comply with the EU5 exhaust emissions standard. Fuel consumption is determined in accordance with the ECE driving cycle (as defined in directive 80/1268/EEC), made up of approximately one third urban and two thirds extra-urban driving (based on the distance covered). CO<sub>2</sub> emissions are measured separately from fuel consumption. Figures relate to standard-specification vehicles, and may vary significantly where optional equipment (including wider tyres) is fitted.

<sup>3</sup> With overboost function.

<sup>4</sup> Assuming car is fuelled to 90% of usable tank capacity, and allowing 68 kilograms for the driver and 7 kilograms for luggage. Figure quoted is for standard-specification vehicles. Optional equipment may increase this figure.

# DIMENSIONAL DRAWINGS.

---

## MINI COOPER COUPÉ.

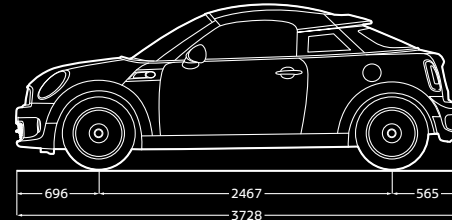
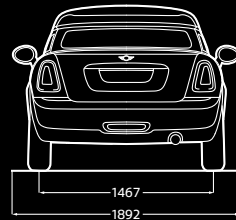
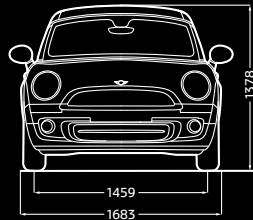

## MINI COOPER S/SD COUPÉ. (MINI JOHN COOPER WORKS COUPÉ.)

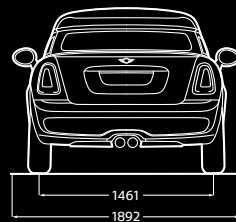
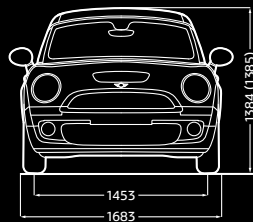

All figures in millimetres.

[MINI.CO.UK/CONFIGURATOR](https://www.mini.co.uk/configurator)

This brochure gives you a broad introduction to the different equipment options and combinations available on the MINI Coupé. But with the Online Configurator, you can find out more about the various models, play around with different combinations of engines, colours and materials, and explore all the different equipment options in more detail. So you can build a MINI that is a unique expression of your own personality.

---

## RECYCLING.

Recycling is central to the MINI philosophy. Every MINI is designed and built in such a way that the materials it is made from can easily be reused at the end of its life cycle, for maximum sustainability. Your MINI dealer will be pleased to advise you on the disposal of your old vehicle. Alternatively, more information on this subject can also be found at [www.MINI.co.uk](http://www.MINI.co.uk)



The models, standard and optional equipment and combinability of options in this brochure relate to cars supplied by BMW AG for the German market. The availability of standard and optional equipment, and the combinability of options, may vary from country to country within the European Union for all models. For detailed information about the situation in your country, please contact your MINI Dealer. Subject to change in design and equipment.

© BMW AG, Munich, Germany. Not to be reproduced, wholly or in part, without written permission of BMW AG, Munich.

UK Part Number: 95.38.0.001.948 AUGUST 2011

For more information, visit [www.mini.co.uk](http://www.mini.co.uk) or [www.mini.ie](http://www.mini.ie)



TEAM GB



OFFICIAL PARTNER



<http://www.facebook.com/MINI.uk>

MINI is affiliated to BMW, an official partner of the London 2012 Games.

111 058 267 21 (L) 2 2011 VM. Printed in Germany.