

CLS-Class



Mercedes-Benz

Rarely have reason and emotion been so closely intertwined

There are times when it can be hard to keep your emotions in check – the moment you first set eyes on the new CLS, for instance. Those elegant lines are guaranteed to capture the heart, while the striking front end never fails to stir the soul. What's more, it's available with all-LED headlamps (optional; standard on CLS Sport) – for a face that's just as distinctive by night as by day.



Boosts testosterone levels, cuts emissions

The looks are breathtaking, the drive exhilarating. Improved engines extract even greater driving enjoyment from each drop of fuel, making for a more intense driving experience – and significantly lower CO₂ emissions.



No amount of words can do it justice

For the new CLS, our designers were asked to create a shape that's both seductive and utterly distinctive. What they came up with was something so striking, it's hard to capture in words – and even harder to resist.





Its exterior is enough to make anyone go weak at the knees. The interior, on the other hand, ensures everyone enjoys optimum support, thanks to a rear passenger compartment that's as much limousine as coupé. In fact, there's only one place you might feel even more comfortable: behind the wheel.





Only the best for your back - and theirs



Exclusivity

A beguiling presence. The sublime new CLS blends athleticism and elegance to winning effect. Its striking exterior exudes style and purpose – and is just as distinctive by night thanks to C-shaped LED indicator strips. Inside, our designers have created an interior that more than lives up to the exterior's promise, with exceptional attention to detail, sumptuous finishes and an exquisite look. The result is a truly captivating travelling companion – for drivers and for passengers.

- Striking four-door coupé body
- High shoulder line with low side windows
- LED Intelligent Light System (optional; standard on CLS Sport)
- Tail lights featuring LED technology
- High-quality interior with handcrafted feel
- Exclusive matt silver interior finish
- Harmonious dashboard design with integrated display
- Ambient interior lighting with choice of three colour settings (optional)

Enjoyment

Pure driving pleasure. The new CLS offers the very highest levels of driving enjoyment. Its engines deliver impressive levels of torque, while 7G-Tronic Plus automatic transmission, highly precise suspension and Direct Steering ensure their power is transferred smoothly and effortlessly to the road. When it comes to fuel consumption, however, the CLS is rather more modest, thanks to a range of BlueEFFICIENCY measures that reduce CO₂ emissions by up to 20% compared to its predecessor. Proof that, with the new CLS, beauty is anything but skin-deep.

- New-generation petrol and diesel engines
- Optimised 7G-Tronic Plus automatic transmission with extremely short shift times and almost imperceptible gear changes
- Selective Damping System
- AirMATIC air suspension (optional)
- Direct Steering for reduced steering effort
- Steering wheel gear shift paddles

The CLS-Class. Simply sublime



Safety

Beauty with vigilance. In the new CLS, the very latest Mercedes-Benz technologies watch vigilantly over your journey. These include Attention Assist, which analyses the driver's behaviour and suggests a break if signs of tiredness or lapses in concentration are detected, and Pre-Safe®, an anticipatory safety system that can recognise an imminent collision and initiate additional occupant protection measures. In addition, the new CLS comes with comprehensive airbag protection as standard, including a driver's side kneebag and a system of sidebags, pelvisbag and windowbags that reacts in accordance with the type of impact. A wide range of optional intelligent safety systems are also available.

- Driving Assistance Package including Active Blind Spot Assist, Active Lane-Keeping Assist and Distronic Plus featuring BAS Plus and Pre-Safe® Brake (optional)
- Lane-Tracking Package with Lane-Keeping Assist and Blind Spot Assist (optional)
- Night View Assist Plus (optional)

Comfort

Your wellness centre on wheels. In the new CLS, exhilaration and relaxation go hand in hand – especially if the optional dynamic multi-contour seats with integrated massage function are fitted. The luxurious yet uncluttered cabin instantly puts you at ease. Generous levels of space for four and automatic climate control ensure you'll still be sitting comfortably after many, many miles. And, unusually for a coupé, there's also a large boot with space for your travel essentials and more.

- Dynamic multi-contour front seats with massage function, active adjustment as you drive and Neck-Pro luxury head restraints (optional)
- Electric seat adjustment
- Comfortable individual rear seats
- Parktronic including Active Park Assist
- Reversing camera (optional)
- Adaptive Brake with Hold function and Hill Start Assist
- COMAND multimedia system with hard drive navigation (optional; standard on V6/V8 models)
- Media Interface for connecting and operating portable media devices

→ www.mercedes-benz.co.uk



CLS standard equipment

The standard equipment for the new CLS includes bi-xenon headlamps and tail lights with LED technology, the innovative Pre-Safe® anticipatory safety system and electronic safety aids such as Attention Assist. Inside, there's fine wood and sporty matt silver finish as well as leather upholstery and electrically adjustable front seats. Also fitted as standard is 7G-Tronic Plus 7-speed automatic transmission: it enhances driving enjoyment and comfort by ensuring the engine is always operating at the optimum speed. In the CLS 350 BlueEFFICIENCY, it works in conjunction with ECO start/stop to help reduce fuel consumption. In addition, the new CLS comes with Navigation 50 (on CLS 250 CDI BlueEFFICIENCY) and COMAND (on V6/V8 models) for first-class sound, standard automatic climate control for your ideal cabin temperature, and rain-sensing wipers that automatically switch on the headlamps in wet weather.



Analogue clock



Direct Select steering column shift lever plus gear shift paddles



Nappa leather 3-spoke multi-function steering wheel



Automatic climate control

CLS Sport standard equipment

The CLS Sport boasts an even more eye-catching look. With AMG bodystyling all round and 19" AMG 5-spoke alloy wheels, it is as distinctive as it is dynamic. The instantly recognisable single-louvre grille complements this exclusive AMG design. Attractive all-LED headlamps and twin exhausts are standard on every Sport. The interior features the AMG sports steering wheel, trimmed in black nappa leather in 3-spoke design. Look toward the footwell and you will find that the Sport also has sports pedals in stainless steel with rubber studs, and floor mats with AMG insignia. Every CLS Sport handles and responds like a sports car, thanks to the electromechanical steering and the sports braking system.



AMG bodystyling featuring twin exhausts



AMG sports steering wheel



19" AMG 5-spoke alloy wheels



All-LED headlamps



Optional extras

From the lighting to the leather upholstery, the new CLS is designed to enhance your sense of well-being. What's more, it can be tailored to your individual tastes and needs via the extensive range of options. These include the Driving Assistance Package featuring Active Lane-Keeping Assist, DISTRONIC Plus and Active Blind Spot Assist, while dynamic multi-contour front seats offer relaxing comfort and excellent support even in fast cornering. Or, for an extra touch of luxury, add the optional Luxury Package which consists of Passion leather seating and door lining, a nappa leather dashboard, armrest and centre console.



The ambient interior lighting offers a choice of three colour settings





COMAND combines the telephone, audio and navigation systems (standard on V6/V8 models)



Harman Kardon® Logic7® surround sound system



The electric glass sunroof with remote control opening



With Night View Assist Plus, an infrared image of the area normally illuminated on main beam can be seen on the central display



Luxury automatic climate control allows the driver, front passenger and rear seat occupants to select separate settings



The Dynamic Multi-Contour Seat Package includes Neck-Pro luxury head restraints



METALLIC PAINTS



197 Obsidian Black



794 Pearl Beige



497 Cuprite Brown

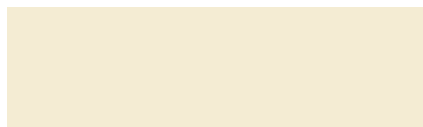

799 Diamond White¹



541 Thulite Red



963 Indium Grey



755 Tenorite Grey



775 Iridium Silver



792 Palladium Silver

designo SPECIAL PAINTS^{1,2}



047 *designo* Alubeam Titanium



057 *designo* Zircon Red

¹Optional

²Special order only, at additional cost

³Optional Passion leather

⁴Optional Luxury Passion leather, only in conjunction with Luxury Package

BLACK

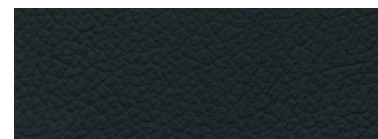

201|801³|501⁴ Leather¹



H19 Light Brown Poplar, matt finish



731 Brown Burr Walnut¹



736 Black Ash¹



H21 Black Piano Lacquer¹



ALMOND BEIGE

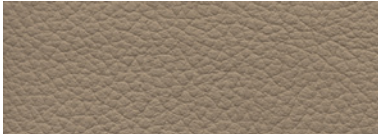

205|805³|505⁴ Leather

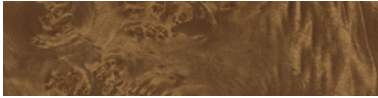

H19 Light Brown Poplar, matt finish



731 Brown Burr Walnut¹



736 Black Ash¹



H21 Black Piano Lacquer¹

BLACK/AUBERGINE

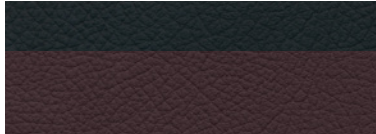

207|807³|507⁴ Leather¹



H19 Light Brown Poplar, matt finish



731 Brown Burr Walnut¹

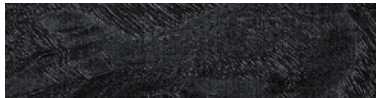

736 Black Ash¹



H21 Black Piano Lacquer¹

ALPACA GREY



208|808³|508⁴ Leather

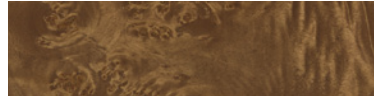

H19 Light Brown Poplar, matt finish

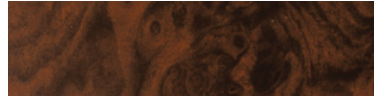

731 Brown Burr Walnut¹



736 Black Ash¹



H21 Black Piano Lacquer¹

BLACK/PORCELAIN



215|815³|515⁴ Leather¹

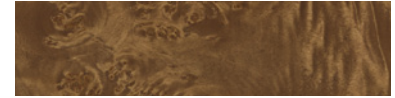

H19 Light Brown Poplar, matt finish



731 Brown Burr Walnut¹

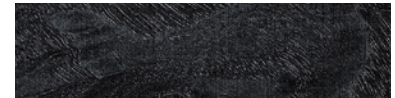

736 Black Ash¹



H21 Black Piano Lacquer¹



Dimensions

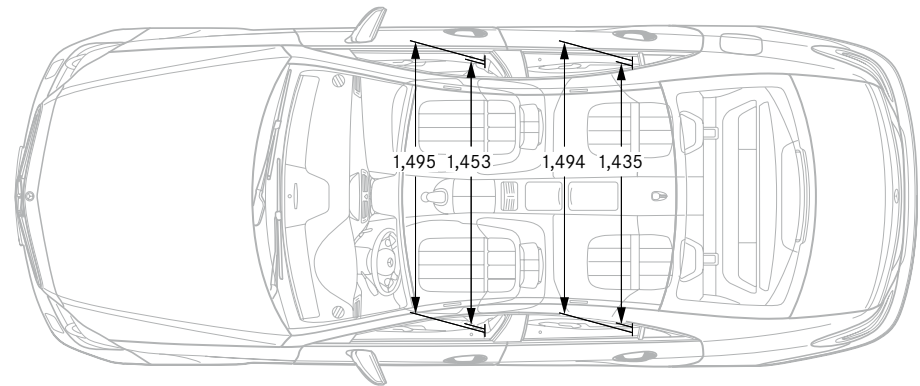
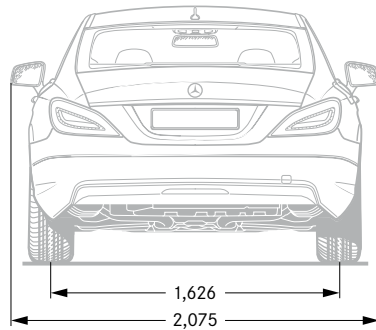
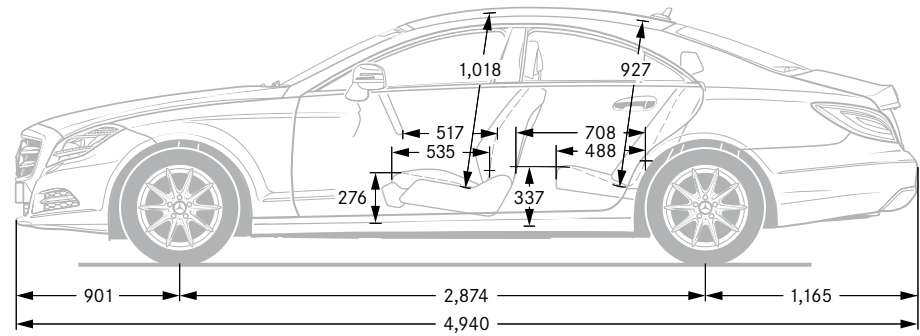
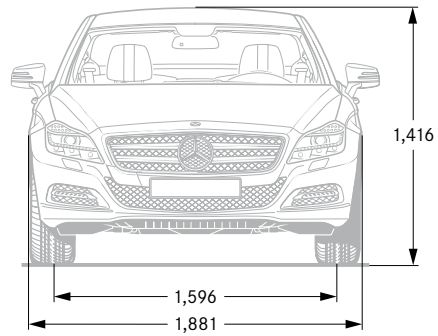

All measurements in millimetres. The dimensions shown are mean values and apply to standard-specification, unladen vehicles



Technical data

No. of cylinders/arrangement
Total displacement – cc
Rated output ¹ – hp (kW) at rpm
Rated torque ¹ – Nm at rpm
Acceleration 0–62 mph – sec
Top speed approx. – mph
Tyre size, front and rear
Fuel
Fuel consumption ³ – mpg
Urban
Extra-urban
Combined
CO ₂ emissions, combined ³ – g/km
EU emissions standard
Tank capacity – l/incl. approx. reserve
Boot capacity – l
Turning circle diameter – m
Kerb weight ⁴ – kg
Perm. GVW – kg

DIESEL ENGINES

CLS 250 CDI BlueEFFICIENCY	CLS 350 CDI BlueEFFICIENCY
4/in-line	6/V
2,143	2,987
204 (150)/4,200	265 (195)/3,800
500/1,600–1,800	620/1,600–2,400
7.5	6.2
150	155 ²
255/40 R 18	255/40 R 18
Diesel	Diesel
44.1	36.2
64.2	55.4
54.3	46.3
135–138	160
EU5	EU5
59/8	80/9
520	520
11.27	11.27
1,800	1,815
2,285	2,300

PETROL ENGINE

CLS 350 BlueEFFICIENCY
6/V
3,498
306 (225)/6,500
370/3,500–5,250
6.1
155 ²
255/40 R 18
Petrol
30.7
51.4
40.9
161–164
EU5
80/9
520
11.27
1,735
2,220

Figures refer to engines with standard 7G-Tronic Plus automatic transmission

¹ Figures in accordance with Directive 80/1269/EEC in the currently applicable version

² Electronically limited

³ The figures shown were obtained in accordance with the prescribed measuring process (Directive 80/1268/EEC in the currently applicable version)

⁴ Figures according to Directive 92/21/EC, version 95/48/EC (kerb weight with fuel tank 90% full, driver, 68 kg, and luggage, 7 kg) for standard-specification vehicles. Optional extras and accessories will generally increase this figure and reduce the payload capacity accordingly

Take-back of end-of-life vehicles. Coming full circle. At the end of its long life, you can return your CLS-Class to us for environment-friendly disposal in accordance with the EC End-of-Life Vehicle Directive.¹ But that day lies a long way off.

¹Applies in accordance with national regulations to vehicles up to 3.5t permissible gross weight. The CLS-Class has met the statutory regulations governing the suitability of the vehicles' design for reuse and recycling for a number of years now. A network of vehicle take-back depots and dismantlers has been established which will process your vehicle in an environment-friendly manner. The ways in which both vehicles and parts can be recovered are subject to ongoing development and improvement. Consequently, the CLS-Class will be able to comply with any future increases in the recycling quota within the stipulated time limits. For further information, please go to www.mercedes-benz.co.uk or call 0808 156 6606.

Please note: changes may have been made to the products since this brochure went to press (13.08.2010). The manufacturer reserves the right to make changes to the design, form, colour and specification during the delivery period, provided these changes, while taking into account the interests of the vendor, can be deemed reasonable with respect to the purchaser. Where the vendor or the manufacturer uses symbols or numbers to describe an order or the subject of an order, no rights may be derived solely from these. The illustrations may show accessories and items of optional equipment which are not part of standard specification. Colours may differ slightly from those shown in the brochure, owing to the limitations of the printing process. This brochure has been compiled by Daimler AG of Germany and is distributed internationally. It provides a general indication of the range of models, features, optional extras and/or colours available in various countries. Some of the models, features, optional extras and/or colours shown may not be available in your country or may only be available in a different specification. Additionally some models, features, optional extras and/or colours may only be available in combination with others. For current and more specific information in relation to the range of models, features, optional extras and/or colours available in your country, and their pricing, you should contact your nearest authorised Mercedes-Benz Retailer. www.mercedes-benz.co.uk

