

# SL-Class



Mercedes-Benz



# Contents

<b>The SL</b>	<b>4</b>	<b>My SL</b>	<b>35</b>
<b>Driving</b>	<b>8</b>	<b>Equipment</b>	<b>35</b>
BlueEFFICIENCY	8	Sports Package	36
Engines	10	Standard equipment	38
Transmissions	15	Alloy wheels	40
Suspension	16	Seat options	44
Steering	17	Optional extras	45
<b>Comfort</b>	<b>18</b>	Retailer-fit accessories	47
Airscarf	18	<i>designo</i>	<b>48</b>
Vario-roof	19	<b>Service and test drive</b>	<b>50</b>
Cockpit	20	<b>Colours and materials</b>	<b>54</b>
Seats	22	Combination options	54
SL 600	23	Trim	55
COMAND	24	Upholstery	56
Surround sound system	25	Paint finishes	57
<b>Safety</b>	<b>26</b>	<b>Technical data</b>	<b>58</b>
Passive safety	26		
Active safety	27		
Intelligent Light System	28		
<b>AMG</b>	<b>29</b>		

## The road is just two letters away from the sky

The SL has long been a legend among sports cars. And yet it's still going from strength to strength. The current model features powerful, yet efficient engines and design highlights such as the dynamic front and rear styling, an exclusive choice of paint finishes and attractive alloy wheels. Discover the SL – the closest connection between road and sky.



## A sporting legend: the SL and the Mille Miglia

We revisited the scene of perhaps the SL's greatest past triumph: the Mille Miglia. This most famous of Italian road races wound its way from Brescia to Rome and back, covered 1,000 miles in three days, and made legends of drivers and cars alike – the SL included. In 1955, a 300 SL piloted by Fitch and Gesell took the GT class by storm, leaving a trail of more fancied machines in its wake. Today's SL is equally at home here. The engine and chassis revel in the glorious winding roads – and the many sleepy villages and magnificent squares en route provide the perfect backdrop for its classic roadster lines.





# The SL





Only a sports car that stirs the soul can truly capture your heart





SL600



D S SL 6001





# BlueEFFICIENCY – technology for more efficient driving

As the inventor of the motor car, we feel we have a special responsibility for improving its resource efficiency – without compromising on safety, comfort and driving pleasure.

Our comprehensive BlueEFFICIENCY measures have already brought significant cuts in fuel consumption to many current Mercedes-Benz models, helping to lower both their CO<sub>2</sub> emissions and their running costs. What's more, we are continuing to develop new environmentally friendly technologies that will reduce emissions even further and help to make motoring more sustainable in the long term.

**BlueEFFICIENCY – the Mercedes-Benz efficiency drive.** In addition to highly advanced and efficient engines, BlueEFFICIENCY models come with a range of energy-saving measures that enable fuel

consumption and CO<sub>2</sub> emissions to be reduced by up to 23%. These measures vary from model to model but can include ECO start/stop, on-demand ancillary components and low-resistance tyres, as well as aerodynamic optimisation and the use of lightweight materials.

**BlueTEC – cleaner diesel power.** BlueTEC is our cleanest diesel technology to date. Its combination of advanced common-rail direct injection, optimised combustion and modular emissions control systems reduces particulate levels by up to 95% and removes up to 90% of nitrogen oxides, leaving little but water, harmless nitrogen and the satisfaction of knowing you've done your bit for the environment.

**HYBRID and BlueTEC HYBRID – the future of internal combustion.** The next stage in our

efficiency drive, hybrid drivetrains will bring new levels of fuel efficiency and emissions reduction to tomorrow's Mercedes-Benz passenger cars. The petrol/electric **HYBRID** system allies an economical internal combustion engine to an electric motor that not only assists the engine when accelerating but also recovers kinetic energy during braking. In addition, the system automatically shuts off the engine as the car slows to a standstill, helping to reduce fuel consumption even further. The diesel equivalent, **BlueTEC HYBRID**, combines the benefits of



BlueEFFICIENCY measures substantially reduce fuel consumption and CO<sub>2</sub> emissions





hybrid drive with the clean-burn technology of BlueTEC. It achieves outstanding fuel economy while keeping harmful emissions to a minimum.

**BlueZERO – the drivetrains of tomorrow.**

The BlueZERO concept showcases three highly developed electric vehicle variants. The E-CELL is an all-electric system driven solely by the battery, E-CELL PLUS pairs battery power with a range-extending internal combustion engine, while the F-CELL features a hydrogen-based fuel-cell stack.



The HYBRID system lowers fuel consumption by up to 20%

**Design for Environment.** Our environmental philosophy is not just about in-car technologies. It also involves taking the entire lifecycle of each vehicle into account, from its initial planning to its end-of-life recycling. We apply the same approach to the building and maintenance of new factories too, saving energy, avoiding harmful emissions and making increasing use of renewable resources. In addition, Mercedes-Benz is involved in the development of alternative fuels and conducts research in the field of bionics.

For more information about what BlueEFFICIENCY can do for you, please visit [www.mercedes-benz.co.uk/blueefficiency](http://www.mercedes-benz.co.uk/blueefficiency)





## Impresses on the road – and at the pump: the SL 300

SL 300

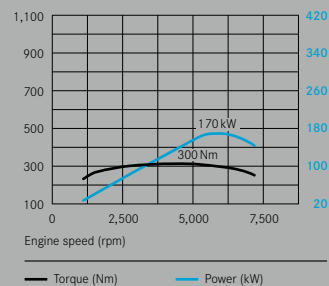

With the 6-cylinder SL engines, you can enjoy admirable efficiency without economising on enjoyment. The SL 300, for instance, offers 231 hp (170 kW) plus 300 Nm of torque, and delivers particularly strong acceleration between 2,500 and 5,000 rpm.

What's more, the long final drive ratio helps to minimise fuel consumption, which together with the generous 80-litre fuel tank, enables it to achieve a highly impressive range.



# More power, less thirst: the SL 350

Whichever engine you choose, your SL will never leave you wanting more. The SL 350's V6, for instance, combines a muscular 315 hp (232 kW) and 360 Nm of torque with an irresistible appetite for revs. The result is 0 to 62 mph in 6.2 seconds and effortless acceleration all the way up to

7,200 rpm. What's more, the SL 350 is not just faster than ever, it's more efficient too, achieving lower fuel consumption and CO<sub>2</sub> emissions thanks to the improvements in the engine's compression ratio and a cylinder head with optimised air intake.



SL 350

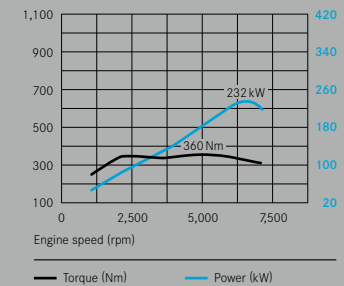



## V8 muscle in a velvet glove: the SL 500

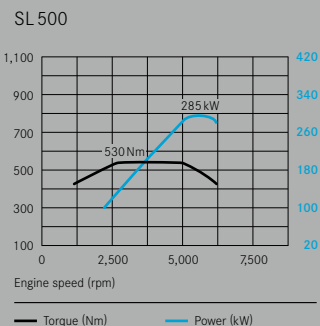

Few sounds are more satisfying than the baritone rumble of a big V8. And few big V8s are more satisfying than that of the SL 500. Its 388 hp (285 kW) ensures exhilarating acceleration, with 0 to 62 mph taking just 5.4 seconds. And its 530 Nm of torque and smooth delivery make it a pleasure at any speed.

These impressive figures are the result of refinements such as a specially developed 32-valve cylinder head. Its continuously variable camshafts ensure optimum combustion at all times, maximising the engine's performance, while reducing its fuel consumption and emissions.



## Driving pleasure on demand: the SL 600

SL 600

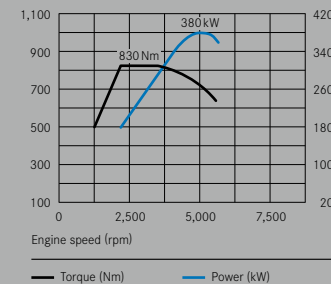

Twelve cylinders, 517 hp (380 kW) and 830 Nm – the SL 600's numbers speak for themselves. And yet the real-life results are even more remarkable: breathtaking acceleration – 0 to 62 mph takes just 4.5 seconds – near inexhaustible reserves of power, and instant response at any speed.

The key to this exceptional responsiveness is the combination of advanced technologies fitted to its V12 engine. These include inter-cooled twin turbochargers, which help to maximise low-speed torque while also minimising fuel consumption.

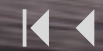



The journey ends,  
but the memory  
lingers on



# The smoothest way to transfer power

The best automatic transmissions change gear without disturbing your driving pleasure. Take 7G-Tronic, for instance. Its seven forward gears mean smaller jumps in engine speed when shifting, making for practically imperceptible gear changes. In addition, it can change down several gears at a time when more powerful acceleration is required.

As an alternative to the standard 7G-Tronic system, the SL 300, SL 350 and SL 500 are available with the 7G-Tronic Sport transmission. It not only enables you to change gear manually via steering wheel gear shift paddles: simply sustain the pressure on the paddle and it automatically jumps to the gear that will give you the most thrust.

The SL 63 AMG offers even faster shifts, thanks to the AMG Speedshift MCT 7-speed automatic transmission. It changes gear swiftly without interrupting the flow of power to the wheels.

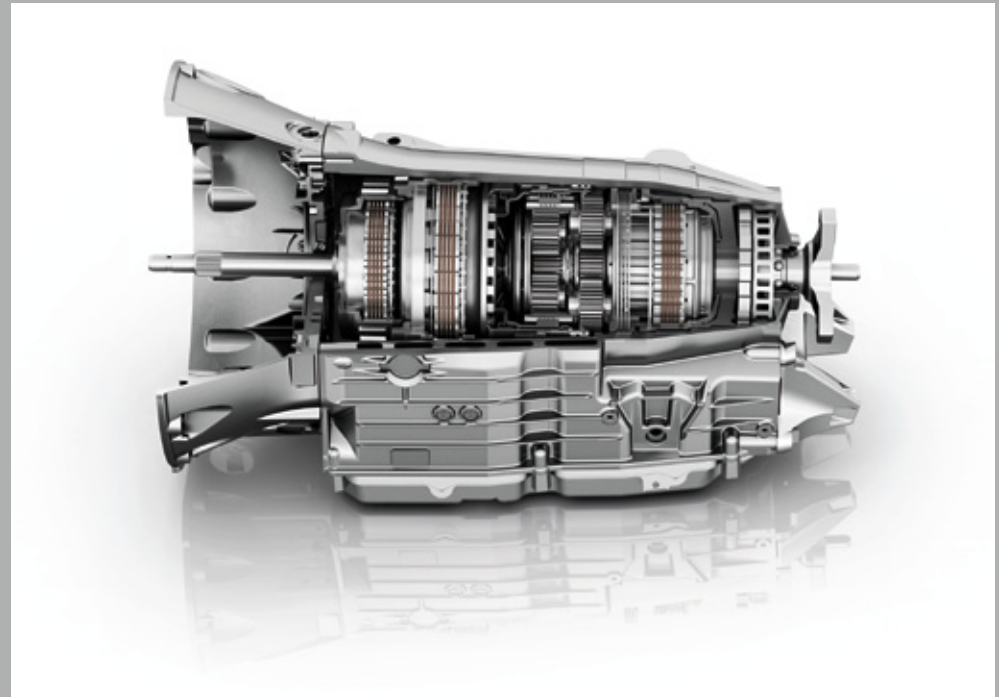

# Reading the road

From bends to straights to city streets, every road requires a different response. That's why the SL comes with Active Body Control (ABC). By monitoring ride height, acceleration and sideways force, it's able to read the situation and adjust the suspension settings accordingly. This enables it to minimise body roll when cornering, for instance, and to compensate for pitching and diving under acceleration or braking.

You can also alter the suspension settings manually – by selecting sport mode whenever you're in the mood. It gives you firmer settings, faster responses and reduced roll, making for sportier cornering and greater stability in emergency manoeuvres.

Active Body Control comes as standard on the SL 500, SL 600 and the SL 63 AMG and is available as an option for the SL 350 (not available on SL 300).





# The direct route to driving enjoyment

The best power steering gives you help when you need it, and feel when you want it. The SL's standard parameter steering, for instance, varies the level of assistance as your speed changes, guaranteeing effortless parking in town as well as optimum stability in motorway driving. The optional direct steering system is even more intelligent. By automatically reducing the amount of lock required to turn the wheels, it makes for safer and sportier cornering, and even easier low-speed manoeuvring, while automatically increasing steering weight at speed. Not that you'll notice it at work. You'll be too busy enjoying the road.

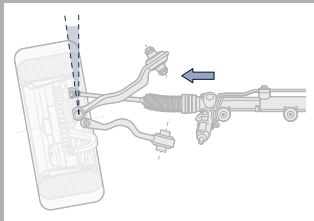

Wheel angle without direct steering

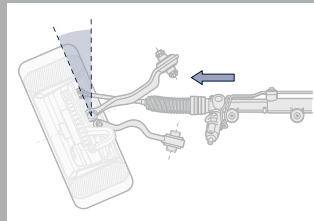

Wheel angle with direct steering  
(using same amount of lock)



## The only scarf that warms you at the flick of a switch

With the ingenious Airscarf, any season can be open-top season. This optional neck-level heating system draws in air via fans in the head restraints, heats it to one of three levels determined by you, then sends it back out through vents in the front of the head restraint. The result is a pleasant stream of warm air to the head and neck – and the freedom to enjoy the wind in your hair whatever the temperature outside.

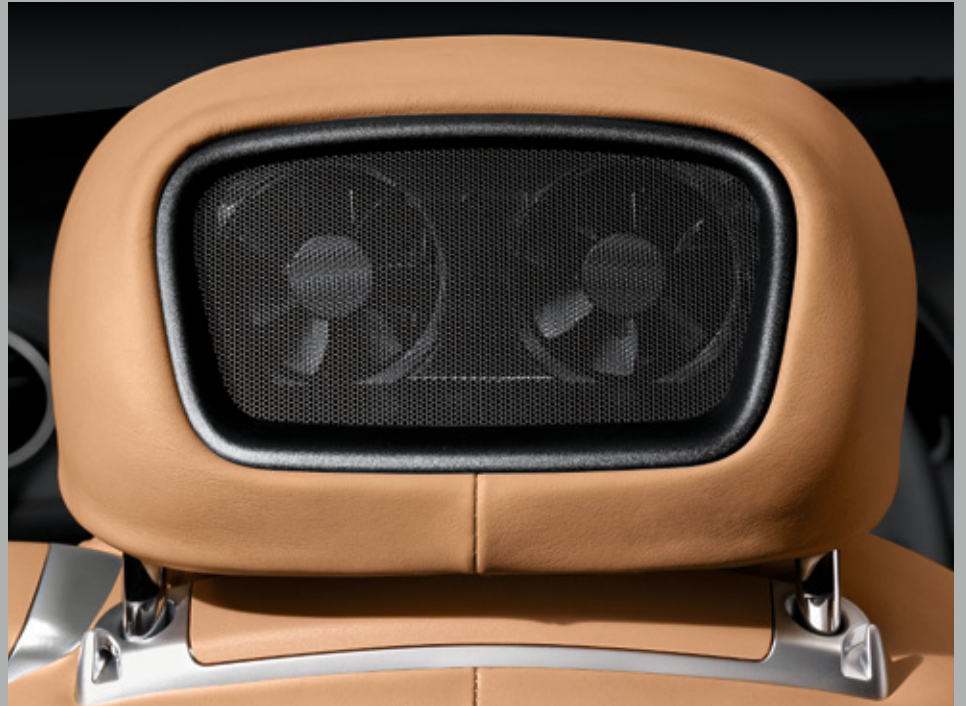



## There's no such thing as bad weather

Thanks to its vario-roof, the SL is a roadster you can enjoy in all weathers. Press a button and it goes from hard-top to drop-top in just 16 seconds, the roof folding away into the boot yet leaving 235 litres<sup>1</sup> of luggage space. With the roof up, there's 339 litres.<sup>1</sup>

But it's not just your luggage that's accommodated in comfort. When the conditions put an end to the open-air entertainment, the vario-roof makes the SL cabin as safe, quiet and comfortable as a coupé's.

In fact, there's only one way to improve on the ingenious vario-roof – and that's with the optional panoramic vario-roof. Made of glass instead of metal, it opens the cabin up to the skies – even when the roof's closed.

<sup>1</sup>With optional Tirefit



## From here, the view is always beautiful

For some of the best views on any road, put yourself behind the wheel of an SL. Not only will you look out over its long, low bonnet, you'll also be able to admire its beautifully finished interior. Sumptuous leather upholstery, wood, aluminium or carbon trim and a nappa leather-trimmed three-spoke sports steering wheel are just some of the many aesthetic highlights.



## Racing feeling at the turn of a key

Start up an SL and it's not just the engine that comes to life. The speedometer and rev counter needles, which sit at six o'clock when the engine's switched off, spring into action too. As soon as you turn the ignition key – or press the starter button if Keyless-Go is fitted – they flick round their respective dials before coming to rest at zero.

What's more, the instruments are eye-catching even when not in action. The two central dials are designed in a 3D chronograph style, while the instrument binnacle features an attractive stitched leather-look finish.

A standard three-spoke steering wheel further enhances the sporty look and feel. As an option, it can be specified with racing-style gear shift paddles (standard with SL600 and with Sports Package).



## Two of the best seats under the sun

The SL seats ensure you enjoy every minute of the journey – even after hours on the road. With stiffened sides and adjustable lumbar supports, they provide optimum support in fast bends, while also keeping back pain at bay over long distances.

In addition, they feature electric adjustment and memory function as standard (optional on SL300), enabling you to find and store your ideal driving position with ease.

The air of luxury extends to the seat trim too. There's a choice of standard leather or optional nappa leather upholstery for all models except the SL600, which comes with Exclusive Nappa leather as standard. Heated seats are standard on all models, while the SL600 seats are also comfort-ventilated, meaning even the stickiest weather won't detract from your driving enjoyment.



## A badge reserved for the privileged few

It's not just the V12 performance that sets an SL 600 apart, but the V12-badged interior too.

The steering wheel, floor mats and seat backrests all feature special logos, and there's optional Poplar wood trim to go with the Exclusive Nappa leather upholstery.

In addition, V12 models offer even more generous levels of equipment, with a hands-free car phone facility, comfort-ventilated seats and remote boot closing among the standard features. Also fitted as standard is Keyless-Go, which unlocks the door automatically and enables you to start the engine at the touch of a button.



## Your wish is its COMAND

The COMAND multimedia system comes as standard on all SL models. This innovative multimedia system combines audio, navigation and telephone (where fitted) in one easy-to-use system. Thanks to Linguatronic voice control, many of its functions can even be operated via spoken commands.

Other COMAND features include an integral 6-disc CD/DVD changer and a 6.5-inch colour screen for displaying navigation maps, viewing videos or, in conjunction with the optional TV tuner, even watching television. There's also an internal 40 GB hard drive with pre-installed navigation software and ample space for your music or video files, plus a standard Media Interface for playing files direct from your MP3 player or external hard drive.





## A concert hall made for two

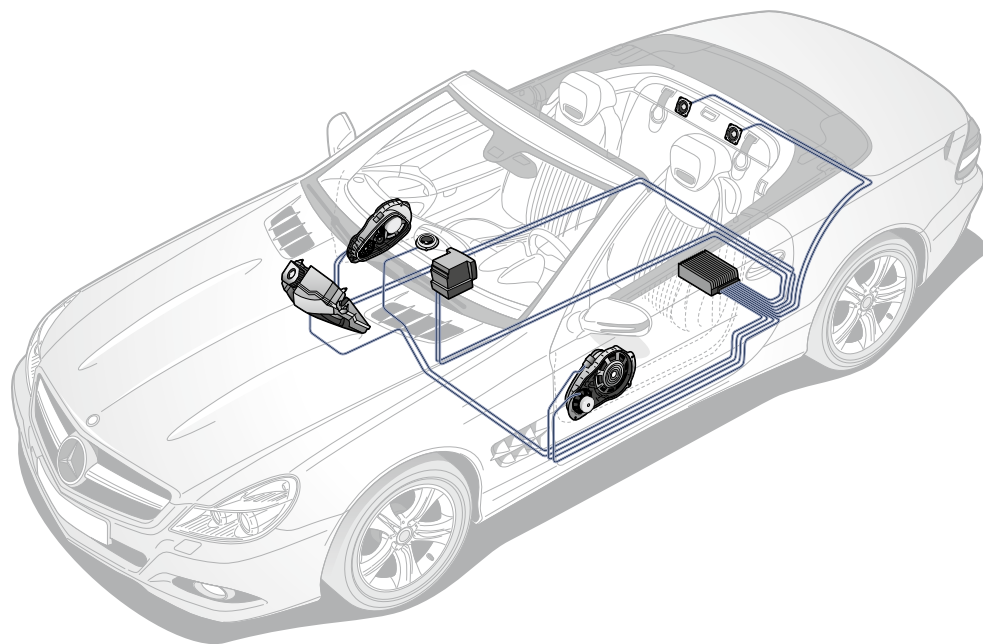

With the Logic 7® surround sound system from Harman Kardon®, you can enjoy open-air concerts wherever you go. Designed specifically to suit the SL's cabin, it comprises ten high-performance speakers, including two surround speakers and one subwoofer, and features Dolby Digital 5.1 for crystal-clear sound.

The surround sound system comes as standard on the SL600 and is available as an option on all other models.



## Safety pioneers since 1959

In summer 1959, Mercedes-Benz launched the first-ever passenger car with passive safety features. Its crumple zones and safety cell were, of course, invisible to the naked eye, yet they changed the way we view vehicle safety for ever. Then, some years later, came the first car fitted with airbags and seat belt tensioners. It, too, was a Mercedes-Benz.

Today, we continue to build maximum occupant protection into our cars right from the start. The SL, for instance, has a highly rigid bodyshell and comes with adaptive airbag technology as standard. To ensure optimum protection when the roof is open, it also features a roll-over bar that's hidden from view during normal driving, but activates within milliseconds when required.

Your SL even helps to ensure your safety – and that of others – after an accident. In the event of an impact, it automatically unlocks the doors, shuts off the engine and switches on the indicators to warn other road users and make the vehicle easier to locate.



# It's just you, your passenger and a team of invisible assistants

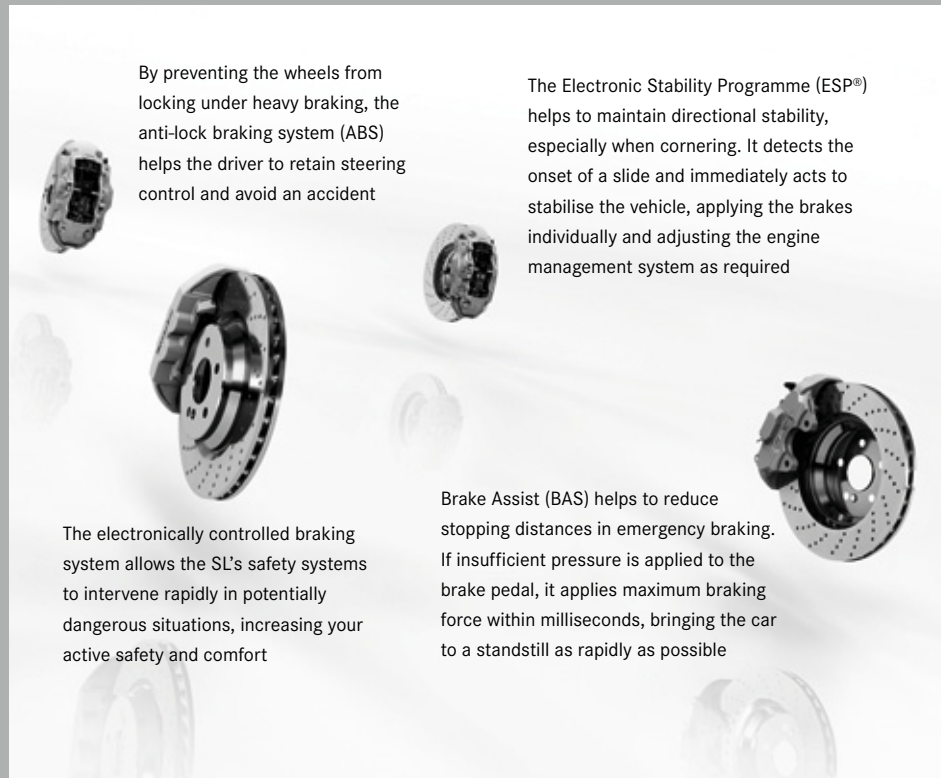

You're never alone in an SL. That's because it's fitted with a whole host of electronic assistants that help you steer clear of danger. The anti-lock braking system (ABS) helps you do exactly that, even under heavy braking, while Brake Assist (BAS) comes to your aid in emergency braking, reducing stopping distance by ensuring maximum brake force is applied. Then there's the Electronic Stability Programme (ESP®). It applies the brakes to individual wheels in order to prevent them losing traction, helps to avoid understeer and oversteer and stops slides before they start.

In addition, the SL comes with an electro-hydraulic brake system. By continuously monitoring vehicle and driver behaviour, it's able to recognise potentially critical situations and take precautionary measures when necessary – such as increasing the pressure in the brake lines and moving the pads closer to the discs, thereby ensuring the brakes bite as soon as you hit the pedal. It also makes for safer mid-corner braking, detects when the road surface is wet and dries the brake discs if required, as well as reducing the pedal pulse sometimes felt when ABS systems intervene.



## Another bright idea from Mercedes-Benz

With conventional headlamps, the beams point straight ahead even if the road doesn't. The SL's optional Intelligent Light System, on the other hand, monitors your steering inputs and angles the beams accordingly, helping you to see further into a bend.

The Intelligent Light System works in conjunction with the standard bi-xenon headlamps and includes an additional cornering light function that helps you to see better at junctions and in turns.

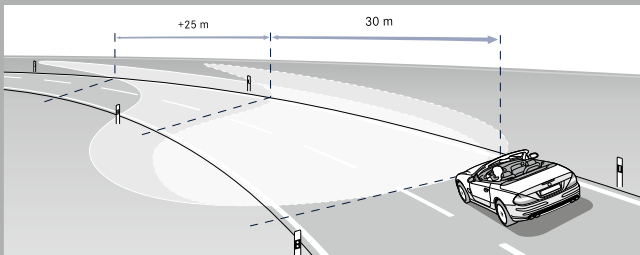

Discover a force you'll  
be powerless  
to resist



## The look of performance

The SL 63 AMG makes a powerful first impression. Its muscular AMG bodystyling and domed AMG bonnet are set off to dramatic effect by 19" AMG triple-spoke alloy wheels, while high-performance brakes with compound discs and six-pin front calipers guarantee a rapid stop from any speed.

At the rear, an AMG boot lid spoiler and two sets of twin tailpipes ensure the SL 63 AMG makes a strong impression on those it leaves behind.



## Driving is believing

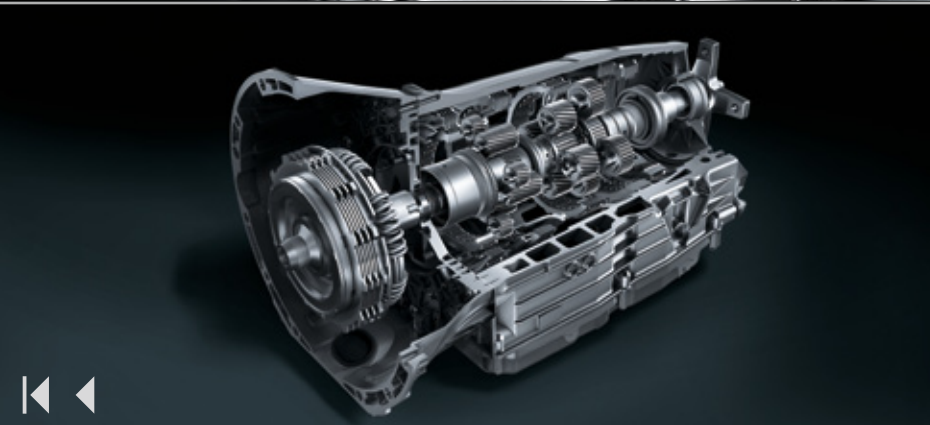

On the road, the SL63 AMG is simply breathtaking. Its 6,208 cc V8 unleashes 525 hp (386 kW) and 630 Nm of torque and is allied to the AMG Speedshift MCT system. This innovative 7-speed automatic transmission offers exceptionally fast gear changes – plus a choice of four driving modes. From manual control via the standard steering wheel gear shift paddles to effortless cruising in automatic, they let you tailor the driving experience to your mood.

The choice of driving mode, plus the Race Start function, maximises traction when accelerating rapidly from standstill. This AMG Drive Unit, derived from professional motorsport engineering, combines the transmission and chassis control systems in one central console.





## Performance enhancement, AMG style



With options from the AMG Performance Studio, you can intensify the AMG effect. They include an AMG Performance Package that gives your SL63 AMG an even sportier look and feel. It features carefully selected components such as AMG performance suspension, larger compound front disc brakes and a limited-slip differential, as well as forged 19" twin-spoke AMG alloy wheels and a smaller AMG performance sports steering wheel with nappa leather trim.

Further options include AMG illuminated door sills, and an AMG Exterior Carbon Fibre Package, which adds eye-catching black carbon for the side vents, exterior mirrors, rear spoiler and diffuser insert.









## Sportswear at its most elegant

AMG bodystyling is the sporty body kit designed by the performance and design experts at AMG. The components are both stylish and functional, comprising a striking front apron with dynamic-looking larger air intakes, integrated fog lamps, ground-hugging side skirts and a rear apron with black insert. Choose matching 19" AMG alloy wheels in 5-spoke design to round off an even more dynamic look for the SL roadster.



# My SL



## The Sports Package

With the optional Sports Package, you'll not only see the difference, you'll feel it too. From the outside, you'll notice the 19" 5-twin-spoke alloy wheels and dark-tinted tail lights and headlamps. Behind the wheel, you'll appreciate the extra stopping power offered by drilled brake discs and the fingertip control of 7G-Tronic Sport transmission.

It lets you change gear like a racing driver via steering wheel gear shift paddles, while automatically selecting the best gear for maximum acceleration – even in manual mode. On the SL300 and SL350, the Sports Package also features a specially developed air filter for a sportier sound.



## Enough sport for even the keenest enthusiast



Inside the cabin, the enhancements are even more striking. The Sports Package's Black leather upholstery features eye-catching silver stitching, and the centre console, dashboard, armrest and floor mats all continue the double-stitched theme.

The fabric roof lining is in matching black, while the prism-pattern aluminium trim provides the perfect contrast. For an added touch of exclusivity, the steering wheel and gear shift lever are trimmed in nappa leather.



Exterior mirror with integral indicator



Wind deflector



Three-spoke sports steering wheel



COMAND multimedia system

**Standard equipment (selection)**

---

Active Body Control (ABC) (not available on SL 300, optional on SL 350)

---

Adaptive brake lights (LED)

---

Airbags for driver and front passenger plus head/thorax sidebags

---

Alarm system with immobiliser and interior protection (MBSS3)

---

Automatic transmission with Tipfunction and Speedtronic cruise control

---

Bi-xenon headlamps with dynamic range adjustment (includes headlamp wash)

---

Brake Assist (BAS)

---

Centre armrest with storage compartment

---

COMAND multimedia system with radio, Media Interface and Bluetooth® for hands-free telephony

---

Door sill strips in metal

---

Easy-Pack loading system for boot

---

Electro-hydraulic braking system with Hill Start Assist

---

Electronic Stability Programme (ESP®)

---

Door mirrors – electrically operated, folding and heated

---

Headlamp Assist

---

Heat-insulating glass all round

---

Nappa leather-trimmed steering wheel and gear shift (wood- and nappa leather-trimmed in SL 600)

---

Luggage net in passenger footwell

---

Luxury automatic climate control

---



---

Memory Package – electrically adjustable seats with memory; includes door mirror memory and steering column with Easy-Entry function and memory (optional on SL 300)

---

Multi-function steering wheel with trip computer

---

Outside temperature gauge

---

Parameter steering – speed-sensitive power steering

---

Rain-sensing wipers

---

Remote boot release

---

Remote control for vario-roof

---

Roll-over bar with crash sensor and automatic activation

---

Steering column, electric adjustable

---

Seat belt pre-tensioners with belt force limiters for driver and passenger

---

Seats – heated, with electric adjustment

---

Service indicator ASSYST

---

Socket in luggage compartment (12 V)

---

Speedtronic variable cruise control

---

Tyre pressure loss warning system

---

Ventilated glove compartment

---

Wind deflector – fabric

---

## Alloy wheels for your SL

All SL models offer a choice of striking alloy wheels. The SL300 and SL350 come with 17" 5-twin-spoke wheels as standard, the SL500 with 18" 5-spoke wheels, and the SL600 with exclusive 18" V12-design wheels. As an option, all three can be specified with the 18" 5-twin-spoke alloy wheels; the SL350 and SL500 can be specified with 19" 5-twin-spoke alloy wheels as part of the Sports Package.



17" 5-twin-spoke alloy wheels (standard on SL 300 and SL 350)



18" 5-spoke alloy wheels (standard on SL 500)





18" V12-design alloy wheels (standard on SL 600)



18" 5-twin-spoke alloy wheels (optional)



19" 5-twin-spoke alloy wheels (only available with Sports Package)

## AMG and incenio alloy wheels



19" AMG 5-spoke alloy wheels



19" AMG triple-spoke alloy wheels (standard on SL 63 AMG)



19" forged AMG twin-spoke alloy wheels



17" incenio 'Gorgona' 5-spoke design wheels



18" incenio 'Veseli' 5-twin-spoke design wheels



18" incenio 'Nash' 9-spoke design wheels



19" incenio 'Tarka' 5-spoke design wheels

## They'll support you, remember you and even give you a massage

With electric adjustment and memory function (optional on SL 300) as standard, the SL seats help you find, store and recall your ideal driving position, ensuring you're sitting comfortably right from the start. For even higher levels of comfort, they can be ordered with optional air conditioning (standard on the SL 600). At the touch of a button, comfort-ventilated seats channel air through the perforated leather upholstery, helping you to keep cool even in very hot weather. Also among the options are multi-contour seats (fitted as standard on the SL 600 and SL 63 AMG). By inflating or deflating their internal air chambers, they are able to adapt to their occupants' size and shape, ensuring perfect support for all. In addition, they include a massage function that offers gentle back rubs.





The AMG bodystyling front apron



Head restraint with Airscarf neck-level heating



The AMG bodystyling rear apron



Bi-xenon headlamps with Intelligent Light System

Optional extras (selection)	SL 300	SL 350	SL 500	SL 600	SL 63 AMG
7G-Tronic Sport 7-speed automatic transmission with steering wheel gear shift paddles	○	○	○	–	–
Active Body Control (ABC)	–	○	●	●	●
Airscarf – neck-level heating	○	○	○	○	○
AMG bodystyling	○	○	○	○	●
DAB digital radio	○	○	○	○	○
Direct steering	○	○	○	○	–
Distronic – radar-assisted cruise control	○	○	○	●	○
Comfort-ventilated seats	○	○	○	●	○
Harman Kardon® Logic 7® surround sound system with Dolby 5.1/DTS	○	○	○	●	○
Intelligent Light System (ILS) with cornering light function	○	○	○	○	○
Keyless-Go	○	○	○	●	○
Multi-contour seats with massage function	○	○	○	●	●
Panoramic glass sunroof	○	○	○	○	○
Parktronic – audible and visual parking aid	○	○	○	●	○
Sports Package	○	○	○	–	–
TV tuner (for analogue and digital reception)	○	○	○	●	○

● Standard   ○ Optional   – Not available



## Retailer-fit accessories



Our Retailer-fit accessories range lets you tailor your SL to your needs, with useful and attractive extras such as easily interchangeable mobile phone cradles for a variety of handsets. The high-quality enhancements also include illuminated door sills whose Mercedes-Benz lettering

underlines the exclusivity of your chosen roadster. For more information about these and other accessories, please talk to your Mercedes-Benz Retailer.

For an SL that's even more individual, turn to the *designo* range. It offers a choice of eleven *designo* interior colours, including both single-tone and two-tone interiors. Once you've chosen your colour scheme, it's on to the upholstery, which comes in either *designo* nappa or *designo* Exclusive Nappa leather. The latter includes additional highlights such as leather trim in your chosen *designo* colour for the parcel shelf and lower section of the dashboard and door panels.

The possibilities don't stop there however. You can also tailor the interior ambience with one of the *designo* wood or stone trim options - choose between the warmth of a wood trim such as *designo* Natural Maple Grain or *designo* Natural Matt Oak Grain, the refinement of *designo* Black Piano Lacquer trim or the cool elegance of Labrador Blue Pearl or Star Galaxy stone. For the finishing touch, there are three Alcantara® roof linings with matching A- and C-pillar trim, plus ten *designo* metallic exterior finishes, including three matt metallics. For more information visit [www.mercedes-benz.co.uk/designo](http://www.mercedes-benz.co.uk/designo)







Centre console in *designo* Black Piano Lacquer trim (W69) with gear shift lever in Black *designo* leather



*designo* Black Piano Lacquer trim (W69) and door centre panels in fluted Pastel Yellow *designo* leather (X12)

# Following the star

## Mercedes-Benz Roadside Assistance

Rest assured that should you ever need help, Mercedes-Benz Roadside Assistance is there for you. In the unlikely event of a technical breakdown<sup>1</sup> you can rely on the Mercedes-Benz Roadside Assistance Team – anywhere in Europe. Simply phone our Customer Assistance Centre on 00800 1 777 7777,<sup>2</sup> where our specialists will organise assistance for you.

Mercedes-Benz will also assist you in the event of a minor mishap preventing you from driving your vehicle.<sup>3</sup> Whether you lose your key, run out of fuel or your vehicle is damaged due to an accident or vandalism, we ensure that you still reach your destination.

Often the problem can be rectified on the spot, but if this is not possible, we will naturally ensure that your vehicle is taken to the nearest Mercedes-Benz Official Workshop to get you back on the road as quickly as possible.

<sup>1</sup>Technical breakdown cover is initially valid for your vehicle for four years from the date of first registration. This can be extended from the fifth year, up to a maximum of 30 years, on completion of each scheduled maintenance service, providing that this service is carried out by a Mercedes-Benz Official Workshop

<sup>2</sup>In non-affiliated European countries: +49 20 7975 7077

<sup>3</sup>This cover can be retained from the fifth year. Your Mercedes-Benz Official Workshop will provide details of how to renew this cover once your initial four year term has expired



## To be continued – with a test drive

A Mercedes-Benz is most at home on the road. This is the only way to experience the effortlessly superior driving feel that lends every Mercedes model its inimitable class. Feel the power of efficient engines with low fuel consumption, and precise steering designed to really put you in the mood for driving. And experience what true comfort really feels like. The unique feeling of driving a Mercedes cannot be put into words, however. Which is precisely why we'd like to invite you to take a test drive. Your Mercedes-Benz Retailer will be happy to make all the necessary arrangements for you. Simply visit [www.mercedes-benz.co.uk/testdrive](http://www.mercedes-benz.co.uk/testdrive) to request a test drive. We look forward to seeing you.





The SL gives you a true sense of freedom – even when choosing your colours and materials. Because with such a wide range of exterior and interior finishes, including exclusive *designo* options, you're free to tailor your SL to your tastes. See for yourself – by configuring your dream SL at [www.mercedes-benz.co.uk](http://www.mercedes-benz.co.uk) or visiting your local Mercedes-Benz Retailer.

	Leather/ Nappa leather <sup>1</sup> / Exclusive Nappa leather <sup>2</sup>	Black	Natural Beige	Flamenco Red	Sand	Alpaca Grey
<b>NON-METALLIC PAINTS</b>						
Black		●	●	●	●	●
Fire Opal		●	○	△	○	○
<b>METALLIC PAINTS</b>						
Magnetite Black		●	●	●	●	●
Obsidian Black		●	●	●	●	●
Indigolite Blue		●	○	△	○	●
Thulite Red		●	○	●	●	○
Tenorite Grey		●	●	●	○	●
Iridium Silver		●	●	●	△	●
Alabandine Grey		●	○	△	○	●
Palladium Silver		●	△	●	●	●
Pearl Beige		●	△	●	●	△
Diamond White <sup>3</sup>		●	●	●	○	●

● Recommended    ○ Possible    △ Not recommended

<sup>1</sup> Standard on SL 63 AMG, optional on SL 300, SL 350 and SL 500

<sup>2</sup> Standard on SL 600, optional on other models

<sup>3</sup> Additional cost option

## TRIM

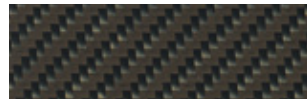
739 Aluminium<sup>1</sup>H73 Carbon fibre<sup>2</sup>H75 Prism-pattern aluminium<sup>3</sup>

## WOOD TRIM

729 Light Poplar<sup>4</sup>731 Burr Walnut<sup>5</sup>736 Black Ash<sup>6</sup>H12 Light Burr Walnut<sup>6</sup>

## ALCANTARA® ROOF LININGS

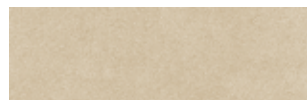
Y83 *designo* AnthraciteY84 *designo* SandY85 *designo* Alpaca Grey*designo* TRIM

W21 Matt Natural Oak Grain



W64 Natural Maple Grain



W69 Black Piano Lacquer

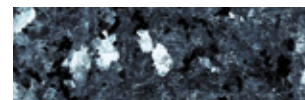

W72 Labrador Blue Pearl stone



W73 Star Galaxy stone

<sup>1</sup>Standard on SL 300 and SL 350, no-cost option on SL 500, not available for SL 600 and SL 63 AMG

<sup>2</sup>Standard on SL 63 AMG, not available for other models

<sup>3</sup>Exclusive to Sports Package

<sup>4</sup>Only available for the SL 600

<sup>5</sup>Standard on SL 500 and SL 600, optional on SL 300 and SL 350, no-cost option on SL 63 AMG

<sup>6</sup>Optional on SL 300 and SL 350, no-cost option on all other models

LEATHER<sup>1</sup>

211 Black

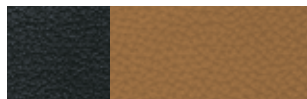

214 Natural Beige



215 Sand

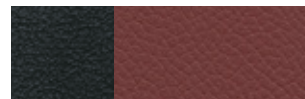

217 Flamenco Red



218 Alpaca Grey

NAPPA LEATHER<sup>2</sup>

801 Black

804 Natural Beige<sup>3</sup>

805 Sand



807 Flamenco Red



808 Alpaca Grey

EXCLUSIVE NAPPA LEATHER<sup>4</sup>

511 Black

514 Natural Beige<sup>3</sup>

515 Sand

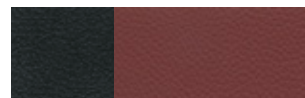

517 Flamenco Red



518 Alpaca Grey

SPORTS PACKAGE<sup>5</sup>

221 Black leather



811 Black nappa leather



521 Black Exclusive Nappa leather

<sup>1</sup> Standard leather codes should be used to order nappa leather for SL 63 AMG

<sup>2</sup> Standard on SL 63 AMG, optional on SL 300, SL 350 and SL 500

<sup>3</sup> Not available for SL 63 AMG

<sup>4</sup> Standard on SL 600, optional on other models

<sup>5</sup> Sports Package only available with Black upholstery with silver stitching, unless *designo* upholstery is selected



NON-METALLIC PAINTS

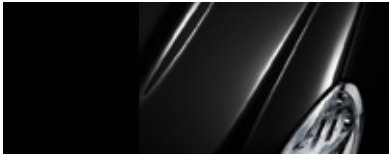

040 Black

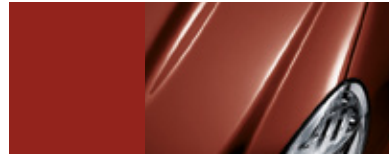

590 Fire Opal

METALLIC PAINTS



183 Magnetite Black

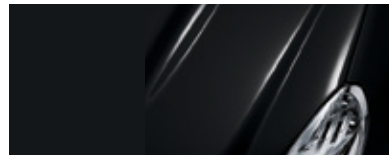

197 Obsidian Black



230 Indigolite Blue



541 Thulite Red



755 Tenorite Grey



775 Iridium Silver

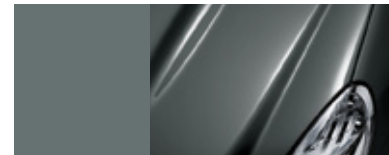

779 Alabandine Grey

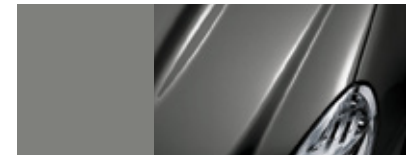

792 Palladium Silver



794 Pearl Beige



799 Diamond White<sup>1</sup>

<sup>1</sup>Additional cost option; special request only

	SL 300	SL 350	SL 500	SL 600	SL 63 AMG
No. of cylinders/arrangement	6/V	6/V	8/V	12/V	8/V
Total displacement – cc	2,996	3,498	5,461	5,513	6,208
Rated output – hp (kW) at rpm <sup>1</sup>	231 (170)/6,000	315 (232)/6,500	388 (285)/6,000	517 (380)/5,000	525 (386)/6,800
Rated torque – Nm at rpm <sup>1</sup>	300/2,500–5,000	360/4,900	530/2,800–4,800	830/1,900–3,500	630/5,200
Acceleration 0–62 mph) – s	7.8	6.2	5.4	4.5	4.6
Top speed approx. – mph <sup>2</sup>	155 <sup>2</sup>	155 <sup>2</sup>	155 <sup>2</sup>	155 <sup>2</sup>	155 <sup>2</sup>
Fuel consumption – mpg <sup>3</sup>					
urban	20.9	20.5	16.3	13.4	13.0
extra-urban	41.5	39.2	33.6	29.4	29.1
combined	30.4	29.1	24.4	20.3	20.0
Combined CO <sub>2</sub> emissions – g/km <sup>3</sup>	217	226	272	326	328
EU emissions standard	EU5	EU5	EU5	EU5	EU5
Unladen weight/ permissible gross weight – kg <sup>4</sup>	1,815/2,110	1,825/2,120	1,910/2,205	2,045/2,320	1,970/2,225
Tyre size <sup>5</sup>	Front	255/45 R 17	255/45 R 17	255/40 R 18	255/40 R 18
	Rear	255/45 R 17	255/45 R 17	255/40 R 18	285/35 R 18
Boot capacity <sup>6</sup> incl. luggage box – l	Roof closed	339	339	339	339
	Roof open	235	235	235	235

<sup>1</sup> Figures according to Directive 80/1269/EEC in the currently applicable version

<sup>2</sup> Electronically limited

<sup>3</sup> The figures shown were obtained in accordance with the prescribed measuring process (Directive 80/1268/EEC in the currently applicable version).

The figures are not based on an individual vehicle and do not constitute part of the product offer; they are provided solely for purposes of comparison between different vehicle models.

All figures are based on the standard specification with the standard alloy wheel/tyre configuration

<sup>4</sup> Figures according to Directive 92/21/EC, version 95/48/EC (kerb weight with fuel tank 90% full, driver, 68 kg, and luggage, 7 kg) for standard-specification vehicles.

Optional extras and accessories will generally increase this figure and reduce the payload capacity accordingly

<sup>5</sup> With standard wheel

<sup>6</sup> With optional Tirefit

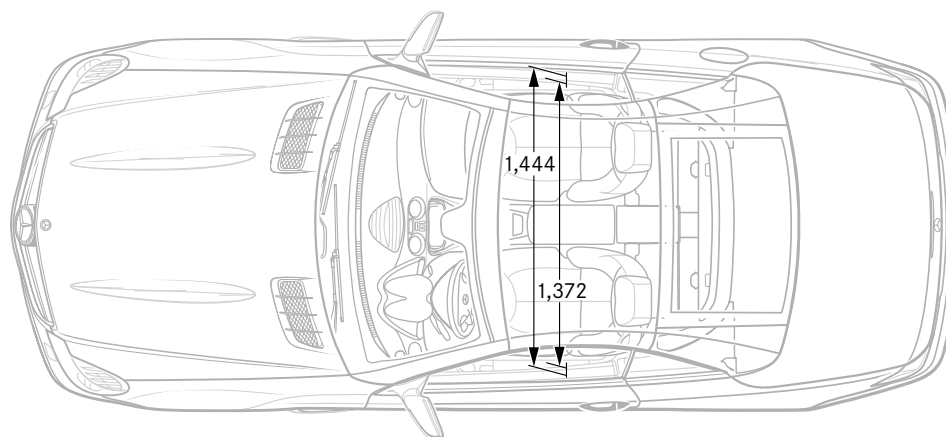
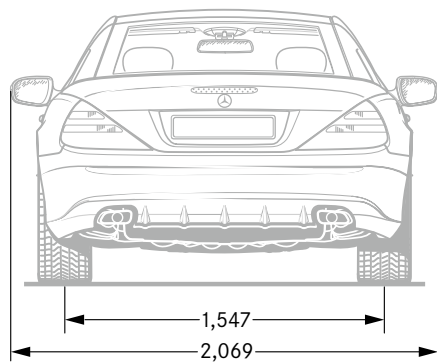
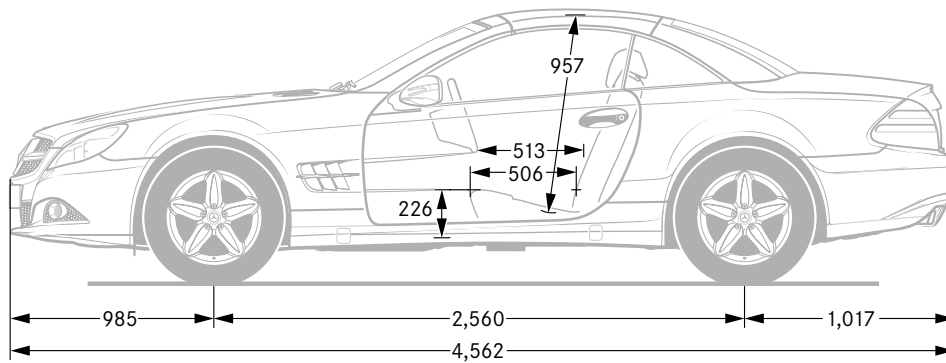
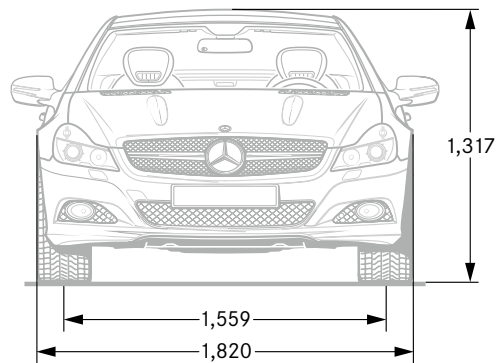

All measurements in millimetres. The dimensions shown are mean values and apply to standard-specification, unladen vehicles



**Take-back of end-of-life vehicles. Coming full circle.** At the end of its long life, you can return your SL-Class to us for environment-friendly disposal in accordance with the EC End-of-Life Vehicle Directive.<sup>1</sup> But that day lies a long way off.

<sup>1</sup>Applies in accordance with national regulations to vehicles up to 3.5 tonnes gross weight. The SL-Class has met the statutory regulations governing the suitability of their design for reuse and recycling for a number of years now. A network of vehicle take-back depots and dismantlers has been established which will process your vehicle in an environment-friendly manner. The ways in which both vehicles and parts can be recovered are subject to ongoing development and improvement. Consequently, the SL-Class will be able to comply with any future increases in the recycling quota within the stipulated time limits. Further information is available at [www.mercedes-benz.co.uk](http://www.mercedes-benz.co.uk) or by calling 0808 156 6606.

**Please note:** this online version of the printed brochure may contain abridged copy or other content changes. The manufacturer reserves the right to make changes to the design, form, colour and specification during the delivery period, provided these changes, while taking into account the interests of the vendor, can be deemed reasonable with respect to the purchaser. Where the vendor or the manufacturer uses symbols or numbers to describe an order or the subject of an order, no rights may be derived solely from these. The illustrations may show accessories and items of optional equipment which are not part of standard specification. Colours may differ slightly from those shown. This brochure provides a general indication of the range of models, features, optional extras and/or colours available in various countries. Some of the models, features, optional extras and/or colours shown may not be available in your country or may only be available in a different specification. Additionally, some models, features, optional extras and/or colours may only be available in combination with others. For current and more specific information in relation to the range of models, features, optional extras and/or colours available in your country, and their pricing, you should contact your nearest authorised Mercedes-Benz Retailer. E&OE.  
[www.mercedes-benz.co.uk](http://www.mercedes-benz.co.uk)