

SLK-Class



Mercedes-Benz





First impressions

The long bonnet, short overhangs and set-back cabin promise unbridled excitement; the drive never fails to deliver. Powerful yet efficient new engines, pin-sharp handling, precision transmissions: the new SLK offers sporting thrills in abundance – yet remains refined and relaxing at all times. Highly supportive sports seats, outstanding ergonomics and luxurious appointments mean this is a roadster that makes even the longest journey a pleasure.

What's more, the SLK is available with innovative new features that further enhance your comfort and enjoyment – such as the optional Airguide wind deflector and the panoramic vario-roof with Magic Sky Control, which switches from transparent to tinted at the touch of a button. As you'd expect from a Mercedes-Benz, the new SLK leads the way when it comes to safety too, combining advanced roadster-specific protection systems with a range of intelligent electronic assistants.

[Overview](#) | [from page 4](#) [Insights](#) | [from page 16](#)

The SLK-Class



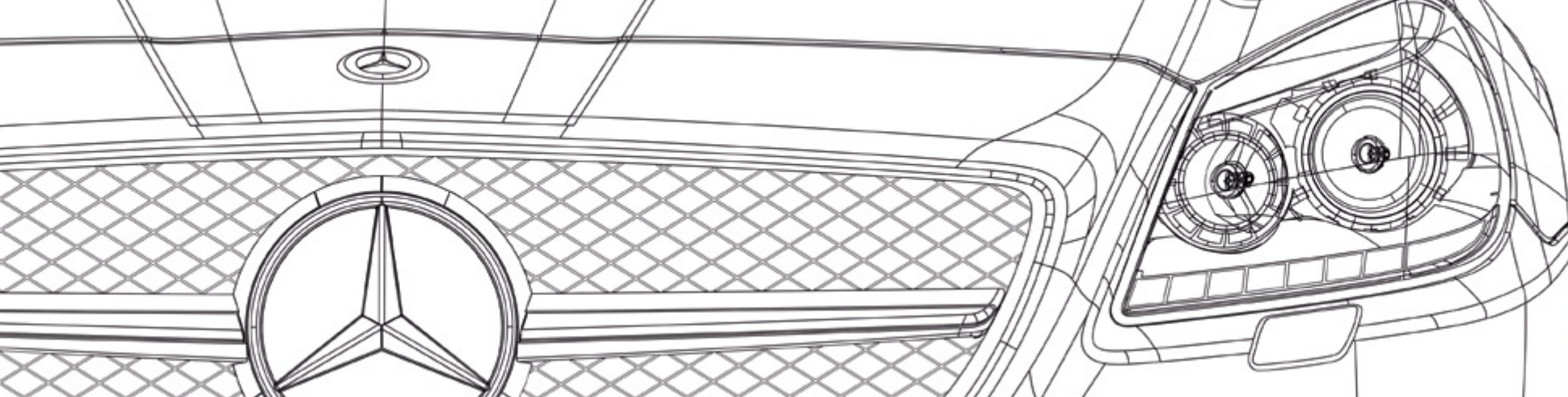

Facts

Unbridled driving pleasure: BlueEFFICIENCY, engines, transmissions and suspension systems.

Engines and suspension | from page 20

Protective instincts: technologies that enhance occupant protection, help to avoid danger and aid rescue in the event of an accident.

Safety | from page 28

Relaxing roadster driving: multimedia systems, electronic assistants, open-top comfort, roof variants, automatic climate control, ergonomic sports seats.

Comfort and convenience | from page 32

Your personal SLK: upholstery and trim, Sport model, *designo*, standard equipment and optional extras, alloy wheels, Retailer-fit accessories.

Equipment | from page 44

More Mercedes-Benz: Mercedes-Benz World and Museum, Roadside Assistance, Mercedes-Benz Finance and Insurance, test drive and Interactive Owner's Manual.

Services | from page 62

SLK in figures: dimensions, paint finishes and technical data.

Facts and finishes | from page 64



Precision driver meets precision driving machine



The roadster perfected



One glance is enough to send your pulse from rest to racing. It's simply a joy to behold – and to drive. Grasp the sports steering wheel, flex your right foot, and feel closer to the road than you've ever felt before.





Rubber grips salt, shattering countless tiny crystals. The scenery begins to blur. The performance is captivating – and nothing can break the spell.



A comet among stars

Day becomes night, another breathtaking journey comes to an end. Reluctantly, you climb out of your low-slung seat and take a long look at those glorious lines. They seem somehow more muscular, more perfect than ever. Perhaps it's your imagination. Or the endorphins that are still coursing through your veins.





Sharp bends, open straights, high-speed manoeuvres: the SLK ensures you enjoy every exhilarating moment, while helping you stay safe at the same time. Its intelligent assistants can monitor changes in the speed limit, help you to keep a safe distance, and even spot signs of tiredness - often recognising the need for a coffee break long before you do.



The face is unmistakable.
The performance unforgettable



Enter here for endless driving pleasure

Make yourself comfortable - in a roadster where intimacy meets Mercedes-Benz luxury. The supportive sports seats fit like a glove; the 3-spoke steering wheel falls perfectly to hand. Around you are intuitive and intelligently placed controls. Has ergonomics ever felt more exhilarating?

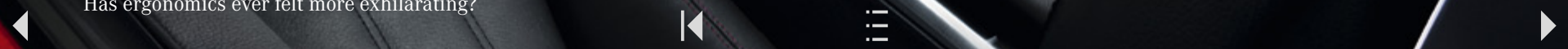

Not even the petrol pump can spoil your enjoyment

Whatever the weather, the SLK rarely gets thirsty. Lightweight materials, excellent aerodynamics and efficient engines help to significantly reduce its fuel consumption, giving you even more pleasure per gallon - and a cleaner conscience to boot.





Roadster driving at its most refined



Enjoy the wind in your hair – without getting a draught in your neck. The SLK's aerodynamic design and optional Airguide help to minimise turbulence, giving the occupants a smoother, quieter ride, while the optional Airscarf keeps heads and necks warm even in cooler open-top driving.



The roof that changes to suit the sky

Open or shut, sunlit or shady: the new SLK lets you choose according to the conditions. Its optional panoramic vario-roof not only folds away in a matter of seconds – it gives you clear sky views even when closed. Choose the panoramic vario-roof with Magic Sky Control and you can alter its transparency at the touch of a button.





A safer form of adrenalin rush

The SLK is built to look after you come what may. With a stiffened bodyshell, large head airbags and Neck-Pro active head restraints, it guarantees not just maximum exhilaration but optimum occupant protection too.



A thoroughbred among roadsters

Since the beginning, roadster driving has always been about horsepower. The term roadster was, after all, first used to describe a type of horse and single-seat cart similar to those still seen in today's harness racing. Intended for short sprints rather than leisurely tours, these light, open two-wheelers were designed for getting from one place to another as quickly as possible. Later, the term was also applied to the breeds of horse developed for such purposes - breeds that were as prized for their elegance as they were for their power, dependability and speed.

Today, you'll find the same blend of qualities in the new SLK, the latest thoroughbred from the Mercedes-Benz stable. Thankfully, though, this particular roadster also gives you two proper seats, ample comfort for longer journeys - and, of course, significantly more than one horsepower.



Let there be light when you want it, and shade when you don't

Ever wondered what it would be like to have power over light and dark? Allow us to introduce Magic Sky Control. With this innovative new technology, you can maximise sunshine or shade at the touch of a button. It uses an electrical charge to change the position of tiny particles suspended in a thin film inside the car's roof, thereby altering the amount of light that enters the cabin. When transparent, Magic Sky Control allows almost 100% of the visible light to penetrate; when darkened, it blocks up to 75% of the light.

Available for the optional panoramic vario-roof, Magic Sky Control also helps to keep the cabin cool in either mode, ensuring you can enjoy maximum sunlight without excess heat – and enabling you to vary the cabin ambience to suit your mood as well as the conditions. There's just one thing, unfortunately, it can't do: make the sun come out on demand.



20 **BlueEFFICIENCY**21 **Efficiency in the SLK**22 **SLK engines**

4-cylinder petrol engines

V6 petrol engine

24 **Transmissions**

6-speed manual transmission

7G-Tronic Plus

26 **Suspension**

Sports suspension

Dynamic Handling Package with sport mode

Direct Steering

28 **Safer driving**

Attention Assist

Intelligent Light System

Distronic Plus

Adaptive Brake System

Brake Assist (BAS Plus)

30 **Occupant protection**

Airbags

Neck-Pro active head restraints

Active Bonnet

Pre-Safe® system

32 **Multimedia systems**

Harman Kardon® Logic 7® surround sound system

COMAND Online

Becker® Map Pilot

34 **Electronic assistants**

Speed Limit Assist

Parktronic with Advanced Parking Guidance

36 **Open-top comfort**

Airsscarf

Airguide

Solar-reflective leather

38 **Roof systems**

Vario-roof

Panoramic vario-roof

Panoramic vario-roof with Magic Sky Control

40 **Climate control and interior lighting**

Automatic climate control

Luxury automatic climate control

Ambient interior lighting

42 **Seats**

Memory function



44 Upholstery and trim

50 SLK AMG Sport

52 SLK AMG Sport interior

54 *designo*

56 Standard equipment

58 Optional extras

60 Alloy wheels

Standard wheels

Optional wheels

AMG wheels

61 Retailer-fit accessories

62 Services

Mercedes-Benz World and Museum

Roadside Assistance

Mercedes-Benz Finance and Insurance

Test drive

Interactive Owner's Manual

64 Dimensions

65 Technical data

66 Paint finishes



BlueEFFICIENCY – technology for more efficient driving

Our comprehensive BlueEFFICIENCY measures have already brought significant cuts in fuel consumption to many current Mercedes-Benz models, helping to lower both their CO₂ emissions and their running costs. What's more, we are continuing to develop new environmentally friendly technologies that will reduce emissions even further and help to make motoring more sustainable in the long term.

BlueEFFICIENCY – the Mercedes-Benz efficiency drive. BlueEFFICIENCY models feature a range of measures that can significantly reduce fuel consumption and CO₂ emissions. They include aerodynamic optimisation, low-resistance tyres and intelligent energy management technologies such as the ECO start/stop function, which comes as standard on an increasing number of models. In conjunction with innovative BlueDIRECT petrol engines, BlueEFFICIENCY measures help the new SLK to achieve reductions in fuel consumption of up to 25%.

BlueTEC – cleaner diesel power. BlueTEC is our cleanest diesel technology to date. Its combination of advanced common-rail direct injection, optimised combustion and modular emissions control systems reduces particulate levels by up to 95% and removes up to 90% of nitrogen oxides, leaving little but water, harmless nitrogen and the satisfaction of knowing you've done your bit for the environment.

HYBRID and BlueTEC HYBRID – the future of internal combustion. The next stage in our efficiency drive, hybrid powertrains will bring new levels of fuel efficiency and emissions reduction to tomorrow's Mercedes-Benz passenger cars. The diesel equivalent, BlueTEC HYBRID, combines the benefits of hybrid drive with the clean-burn technology of BlueTEC.

E-Cell and F-Cell – new drivetrain concepts. We are also committed to the development of electric powertrains that produce zero local emissions. To this end, we've already produced a limited run of our A-Class E-Cell and B-Class F-Cell vehicles. The F-Cell uses a hydrogen fuel cell to drive its electric motor, while the E-Cell is powered solely by twin lithium-ion batteries.

Design for Environment. Our environmental philosophy is not just about in-car technologies. It also involves taking the entire lifecycle of each vehicle into account, from its initial planning to its end-of-life recycling. We apply the same approach to the building and maintenance of new factories too, saving energy, avoiding harmful emissions and making increasing use of renewable resources. In addition, Mercedes-Benz is involved in the development of alternative fuels and conducts research in the field of bionics.

For more information about what BlueEFFICIENCY can do for you, please visit
www.mercedes-benz.co.uk/blueefficiency



Efficiency in the SLK

The SLK combines power and performance with innovative BlueEFFICIENCY measures that help to optimise fuel economy and reduce CO₂ emissions.



Environmental protection and energy conservation are of ever increasing importance, with CO₂ emissions, fuel consumption and the cost of fuel all key issues for today's drivers. That's why we've made every new SLK model a BlueEFFICIENCY model, fitting each with a comprehensive range of fuel-saving features. These include:

- 1 Aerodynamic exterior mirrors
- 2 Tyres designed for lower rolling resistance
- 3 ECO start/stop function
- 4 Air conditioning compressor only active when required
- 5 Intelligent alternator management (switches off under acceleration)
- 6 Energy-saving oil, water and fuel pumps and power steering pump (on-demand operation)
- 7 Current fuel consumption display
- 8 Shift point indicator for models with manual transmission
- 9 All engines meet EU5 emissions standards
- 10 Efficient technologies such as direct petrol injection and turbocharging
- 11 Optimised aerodynamics thanks to adjustable radiator shutter (SLK 200 BlueEFFICIENCY)



SLK engines

Our latest-generation petrol engines prove driving pleasure and efficiency can go hand in hand. Thanks to innovative technology, they combine powerful performance with low fuel consumption and emissions.

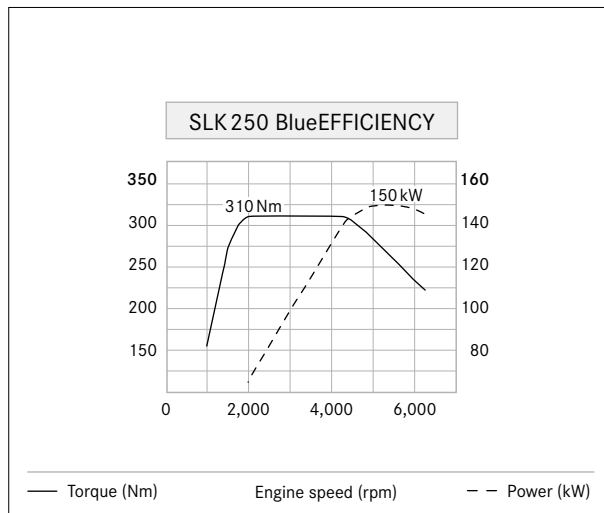

With an output of 204 hp (150 kW), the SLK 250 BlueEFFICIENCY delivers sporty performance

4-cylinder petrol engines. Direct petrol injection, turbocharging and twin overhead camshafts help the SLK's optimised 4-cylinder petrol engines to deliver high levels of power and torque along with low fuel consumption and emissions.

More complete combustion and variable valve control ensure these innovative engines use fuel more efficiently, while weight savings and lower internal friction help to further reduce their fuel consumption. In addition, 4-cylinder SLK models come with the fuel-saving ECO start/stop function, which cuts the engine automatically at traffic lights and when queuing, and meet the stricter Euro 5 emissions standards.

The SLK offers a choice of two 4-cylinder petrol models: the SLK 200 BlueEFFICIENCY delivers 184 hp (135 kW) and 250 Nm of torque; the SLK 250 BlueEFFICIENCY has 204 hp (150 kW) and 310 Nm of torque. Both feature twin balancer shafts for optimum refinement yet deliver a satisfying sound that underlines the car's sporting intentions.

V6 petrol engine. The new V6 for the SLK 350 BlueEFFICIENCY improves performance yet cuts fuel consumption and CO₂ emissions similarly by more than 20%. High-pressure direct petrol injection with spray-guided combustion and ultra-precise piezo injectors help it deliver an output of 306 hp (225 kW) and a maximum 370 Nm of torque, while the standard ECO start/stop function, new intake and exhaust system, on-demand ancillaries, intelligent alternator management and lightweight construction all further enhance its fuel efficiency. The engine responds instantly even at low revs and delivers a typically satisfying 6-cylinder sound, while remaining highly refined at all speeds.



The SLK engines combine driving pleasure with low fuel consumption and emissions

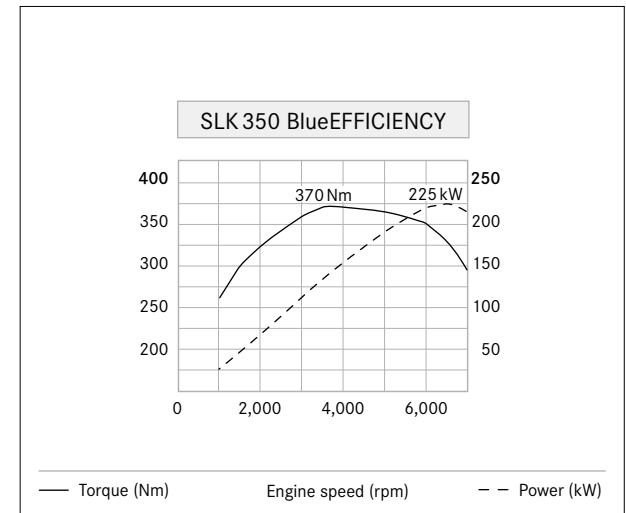

The SLK 350 BlueEFFICIENCY features a state-of-the-art direct petrol injection V6

Transmissions

The transmissions for the new SLK are perfectly matched to its engines. They offer a choice of manual and automatic systems, enable you to opt for a sporty or economical driving style, and are ergonomic and easy to use.

6-speed manual transmission. The SLK 200 BlueEFFICIENCY features our 6-speed manual transmission. It offers quick and precise gear changes, with ratios carefully matched to engine performance, and helps you save fuel by indicating the most efficient shift point in the instrument panel.

7G-Tronic Plus. The latest version of our 7-speed automatic transmission is fitted as standard on the SLK 250 BlueEFFICIENCY and SLK 350 BlueEFFICIENCY and available as an option for the SLK 200 BlueEFFICIENCY.

It ensures the engine is always operating at the optimum speed, delivers faster, smoother shifts and provides better acceleration, even skipping gears in kickdown for more rapid overtaking.

One of the key improvements for 7G-Tronic Plus is the addition of a new-generation torque converter that delivers even sportier throttle responses, greater durability, lower noise levels and significantly improved efficiency. 7G-Tronic also allows you to select either economy or sport mode via a switch in the

centre console. If the optional steering wheel shift paddles are fitted, there's also an additional manual mode for even faster gear changes.

Both manual and automatic models come with ECO start/stop function as standard. It cuts the engine automatically at traffic lights and when queuing, helping to further reduce fuel consumption.



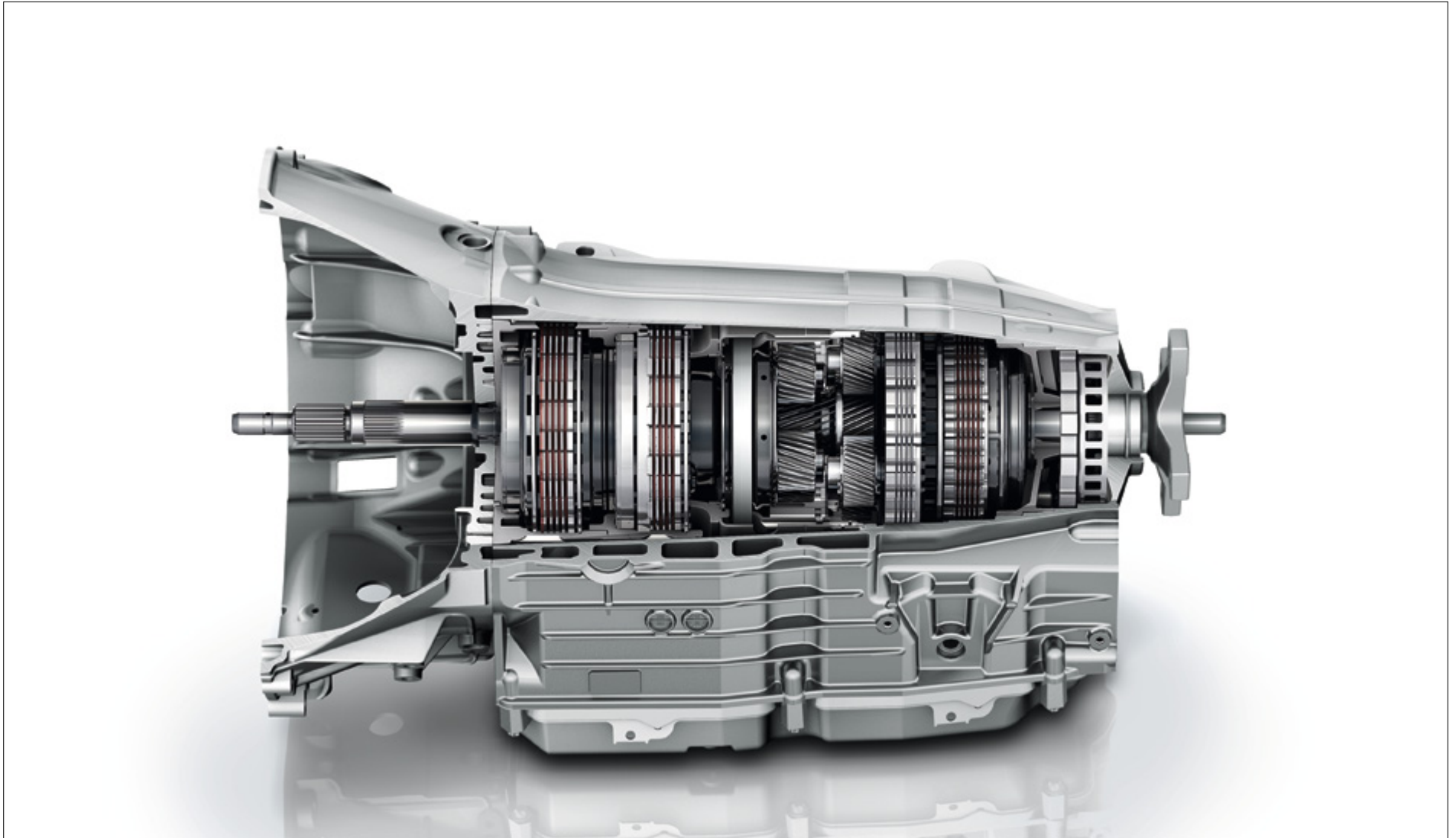

7G-Tronic Plus: the result of more than 50 years' experience in automatic transmission technology



Suspension

The SLK is set up to give you both dynamic handling and remarkable ride comfort. The lowered sports suspension further increases agility, while the Dynamic Handling Package includes a sport mode for even greater driving enjoyment.

Sports suspension (optional; standard on SLK AMG Sport). On the SLK AMG Sport, a 10-millimetre lower sports suspension is fitted as standard. It features shorter springs and firmer dampers plus larger-diameter anti-roll bars that reduce body roll and enhance stability.

Dynamic Handling Package with sport mode (optional). The optional Dynamic Handling Package features an electronically controlled damping system that continuously adjusts the damping levels at each wheel to the

current situation and surface. The result is greater stability at all speeds – and a significant increase in driving enjoyment. The package also includes a sport mode that enables you to opt for firmer settings at the touch of a button, and a separate ‘E/S’ switch that gives you faster shifts and more rapid acceleration on demand (automatic models only).

Direct Steering (optional, standard with Dynamic Handling Package). Direct Steering combines the speed-sensitive power assistance from our parameter

steering system with a variable-ratio steering rack. Speed-sensitive assistance significantly reduces the required steering input at low speeds, while the variable-ratio rack translates inputs more immediately to the road. This increases agility and further reduces the effort required for large steering angles, while a less direct ratio in central positions ensures optimum stability in straight-line driving.



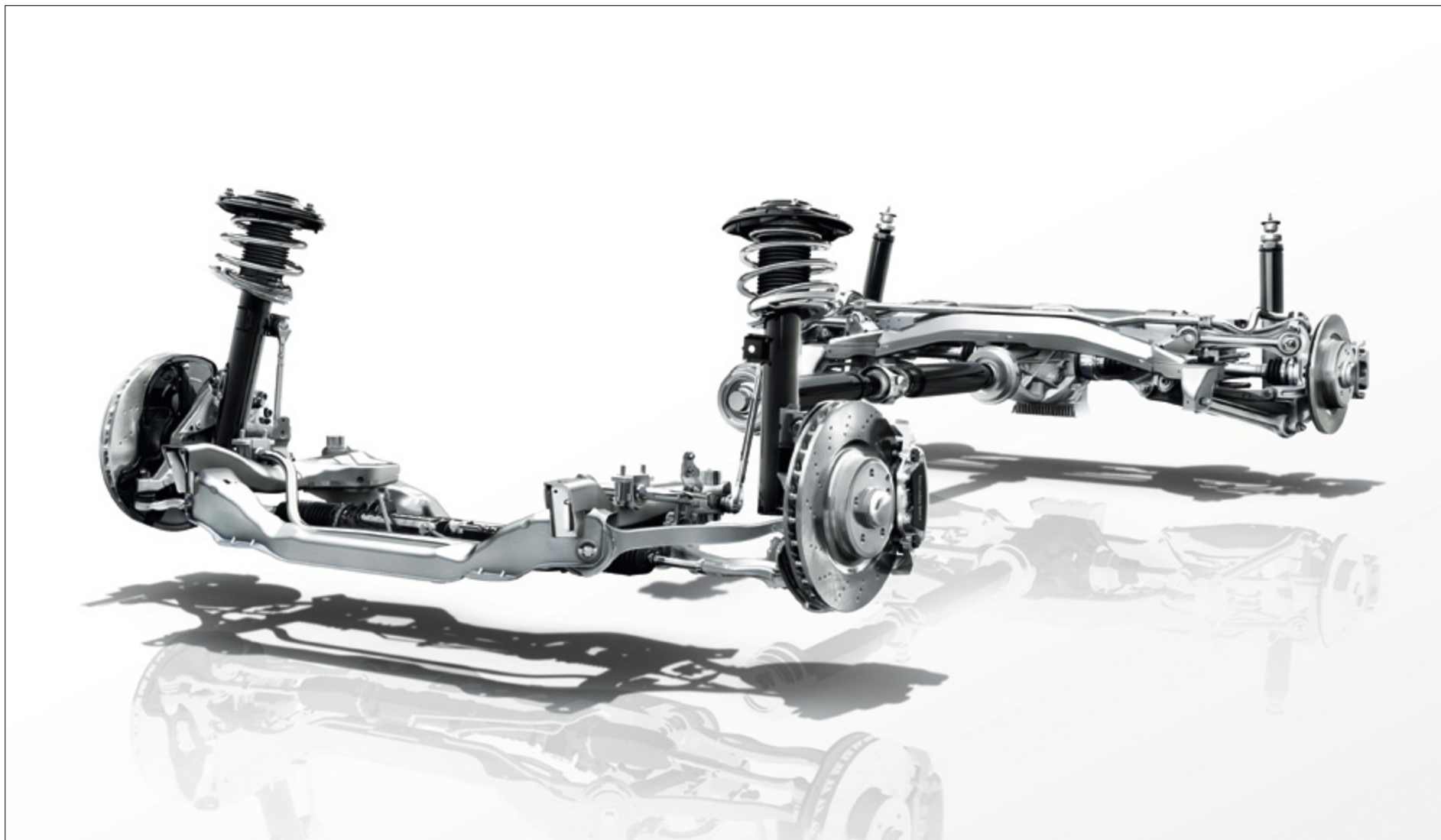

The Dynamic Handling Package offers a perfect blend of agility and comfort



Safer driving

Like all our passenger cars, the new SLK is built according to an integrated safety concept. It combines comprehensive occupant protection with intelligent systems that can help to prevent accidents from occurring.

Attention Assist (standard). Particularly beneficial on long journeys, Attention Assist is an innovative system for detecting fatigue. Between speeds of approximately 50 and 110 mph, it assesses the driver's behaviour via an array of sensors and registers unexpected changes that may indicate tiredness or concentration lapses, such as involuntary movements of the steering wheel.



If it detects signs of tiredness or concentration lapses, Attention Assist suggests taking a break

Intelligent Light System (optional). The Intelligent Light System comprises a variety of modes and functions that help you to recognise the line of the road, and to spot pedestrians or other potential sources of danger earlier and more reliably. Country mode directs extra light towards the side of the road, motorway mode illuminates the entire carriageway, while fog mode helps you see better in low-visibility conditions. Also included are the Active Light System, which angles the headlamp beams in bends, and a cornering light function.



The Intelligent Light System adapts automatically to different roads and conditions

Distronic Plus (optional). Distronic Plus radar-assisted cruise control helps you to maintain the required distance from the vehicle in front. It applies the brakes automatically (bringing the car to a standstill if necessary) and accelerates again once the situation allows. Thanks to Pre-Safe® Brake, the system can initiate an emergency stop approx. 0.6 seconds before an imminent collision, thereby reducing the severity of the impact.

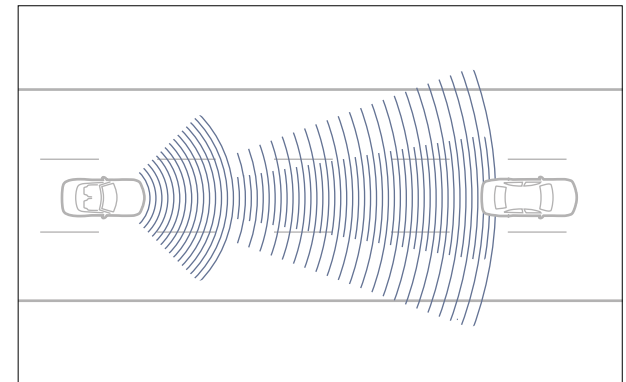

Distronic Plus can automatically maintain a minimum distance between you and the vehicle in front



Adaptive Brake System (standard). Together with the anti-lock braking system (ABS) and the Electronic Stability Programme (ESP®), Adaptive Brake increases safety in potentially difficult braking situations. By drying the brakes in the wet and priming them automatically, it gives you even more rapid braking, while the Hill Start Assist function prevents you from rolling backwards when switching from brake to accelerator on inclines. With the hold function, you can also keep the brakes engaged by twice pressing and releasing the brake pedal.

Brake Assist (BAS Plus) (part of optional Distronic Plus). BAS Plus works in tandem with the Pre-Safe® Brake to help prevent you from colliding with the vehicle in front. This anticipatory system evaluates driving situations using data from the car's radar sensors and increases braking pressure where necessary, based on the distance to the other vehicle and your relative speeds. If the sensors detect the possibility of a collision and the driver applies the brakes in time, BAS Plus ensures sufficient braking pressure is applied for the available braking distance.



The adaptive brake lights increase safety by flashing during heavy braking, immediately alerting those behind



Occupant protection

Our integrated safety concept helps the SLK to provide optimum protection for its occupants – even if an accident should prove unavoidable.

Airbags (standard). Since October 1992, airbags have been fitted to all Mercedes-Benz passenger cars. The SLK comes with six as standard: two dual-stage front airbags, sidebags in each of the seat backrests, and head airbags inside the doors that help to reduce the impact of a side-on collision or roll-over. All six work in tandem with the seat belts to help minimise the risk of injuries.

Neck-Pro active head restraints (standard). The Neck-Pro active head restraints help to improve impact protection and reduce the risk of whiplash injuries. In the event of a rear-end impact, they are raised by 30 millimetres and move approximately 40 millimetres further forward, enabling them to support the head sooner.

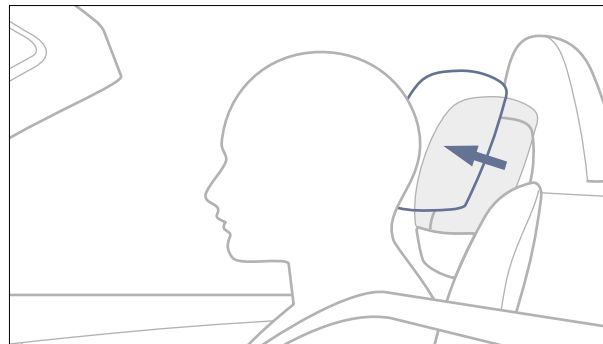

The Neck-Pro active head restraints reduce the risk of whiplash injuries in the event of a rear-end impact

Active Bonnet (standard). If a pedestrian or cyclist hits the front of the new SLK, the rear of its bonnet is lifted by 8.5 centimetres, helping to reduce the risk of injury. Active Bonnet deploys automatically at speeds of between approx. 15 and 35 mph.

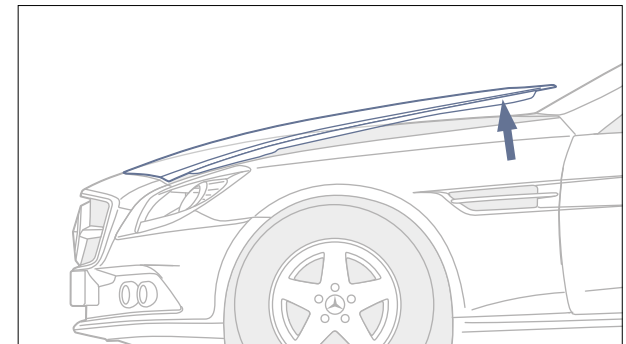

Active Bonnet is part of a range of measures by which Mercedes-Benz helps to protect more vulnerable road users



Pre-Safe® system (standard). Pre-Safe® continuously evaluates sensor data from systems such as ESP® and BAS Plus, enabling it to recognise signs of danger such as emergency braking or heavy under- or oversteer. If a probable accident scenario is detected, Pre-Safe® can then take a range of anticipatory measures to protect the occupants. These include activating the reversible seat belt tensioners, automatically closing the windows and moving the passenger seat to a safer position (if optional memory function is fitted).

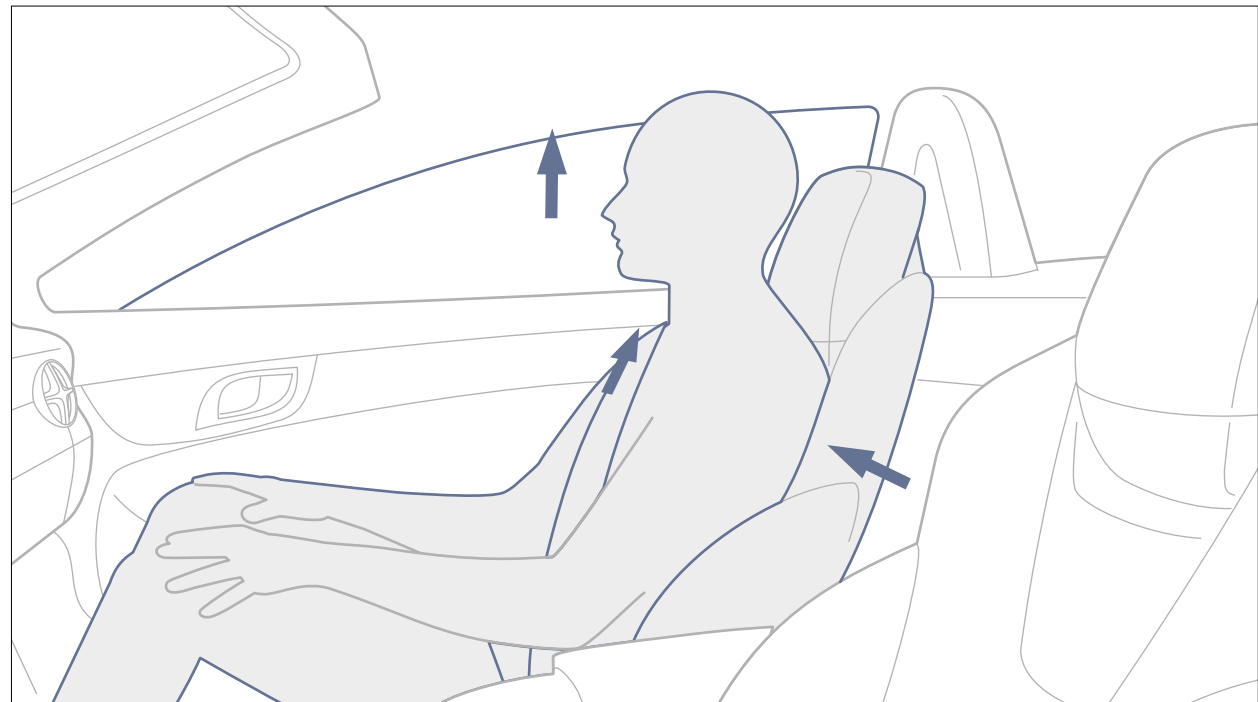

Multimedia systems

The entertainment and navigation options for the SLK include the new COMAND Online multimedia system. It can be operated either via the central controller or the multi-function steering wheel – or hands-free thanks to Linguatronic voice control.

Harman Kardon® Logic 7® surround sound system (optional). With its subwoofer, 9-channel DSP amplifier and 3D spatial sound, this 400-watt 11-speaker system delivers a truly first-class audio experience. It also maintains optimum clarity and enjoyment at all times, thanks to Dolby Digital 5.1 and speed-sensitive volume adjustment.



The Harman Kardon® Logic 7® surround sound system brings high-end audio to the SLK cabin

COMAND Online system with Media Interface (optional). The COMAND Online multimedia system combines hard-drive navigation with entertainment features such as a tuner, speed-sensitive volume adjustment, an audio file library with 10 GB of storage space, and a DVD drive that plays CDs, MP3s, and video or audio DVDs. It also enables you to connect a variety of external devices and storage media – via USB port, aux-in socket, SD memory card slot or Bluetooth® interface – and lets you access the internet as well as a variety of online Mercedes-Benz services (internet-enabled mobile phone required). Maps and menus are presented on a high-resolution 5.8-inch colour display (three years of map updates are offered free of charge) and all key functions can be operated either via the central controller, from the multi-function steering wheel or using Linguatronic voice control. Also available with integrated 6-disc changer.

Becker® Map Pilot (optional). With the new Becker® Map Pilot, you'll always reach your destination as safely and quickly as possible. Map Pilot can be integrated with the Audio 20 radio/6-disc CD changer's central controller and display, turning it into a fully featured navigation system, and tailored to your needs by downloading additional functions and map data.



Becker® Map Pilot can be integrated with and operated via the Audio 20 radio/6-disc CD changer





Electronic assistants

The SLK offers a range of intelligent assistants that help to make SLK driving safer and more convenient – be it on the open road or in tight parking spaces.



Speed Limit Assist (fitted with the optional COMAND Online system). Thanks to its front-mounted camera, Speed Limit Assist can read speed limit signs and display the permitted maximum speed in the car's instrument panel. It is particularly useful in areas where the speed limit varies or when passing through roadworks.



Speed Limit Assist shows the current speed limit in the instrument panel and in the central COMAND Online display

Parktronic with Parking Guidance (optional). Parking Guidance can help you to find and manoeuvre into parking spaces. At speeds of up to around 20 mph, it measures gaps in lines of parallel-parked cars using ultrasound sensors and alerts you as soon as it finds a suitably sized space. Once reverse is engaged, it then guides you in via a combination of acoustic signals and graphics in the instrument panel, showing the required steering angle and telling you when to turn



Parking Guidance identifies suitable parking spaces and helps you to manoeuvre safely in

the wheel. If the car is at an angle after the initial reversing manoeuvre, the system can also help you straighten up.

Parktronic, meanwhile, helps you to avoid low-speed knocks when manoeuvring in tight spaces. It uses up to ten sensors to monitor the areas to the front and rear of the car, alerting you via a visual warning if it detects the proximity of another vehicle or object. Once the distance to the object falls below approx. 35 centimetres, an audible signal is emitted, followed by a sustained warning sound if you continue to approach the obstacle.



Open-top comfort

The new SLK combines roadster thrills with refined comfort – and can be made even more relaxing via enhancements such as the optional Airguide wind deflector.

Airscarf (optional). Airscarf is a Mercedes-Benz innovation that lets you extend the open-top season. Thanks to subtly integrated vents in the head restraints, it can send a stream of warming air towards the head and neck of each occupant, enabling you to keep the roof down even in cooler weather.



The Airscarf neck-level heating system lets you enjoy open-top driving even in cooler weather

Airguide (optional). The new Airguide wind deflector minimises draughts in the cabin during open-top driving. It comprises specially designed Plexiglas® panels fixed to each of the roll-over bars. The panels can be separately rotated into the space between the head restraints, diverting the air flow away from the occupants and thus reducing turbulence around the head area. By improving the aeroacoustics, Airguide also helps to reduce cabin noise.



The innovative Airguide wind deflector significantly reduces draughts with the roof open

Solar-reflective leather (optional; standard on SLK AMG Sport). All leather upholsteries (except *designo* leather) have a solar-reflective coating as standard. In bright sunshine, this special coating helps the seat surfaces to stay cooler, ensuring optimum comfort even on the hottest of days.





Open or closed, SLK driving is always a pleasure



Roof systems

The SLK redefines notions of roadster comfort. All roof variants provide all-weather protection and generous luggage space, while the new panoramic vario-roof with Magic Sky Control offers another SLK first: switchable transparency with the roof closed.

Vario-roof (standard). The electrically operated vario-roof makes the SLK a genuine all-season roadster. Made of lightweight magnesium and synthetics, it transforms the new SLK from a two-seater coupé into an open-top roadster in less than 20 seconds. The vario-roof folds neatly away into the boot, leaving ample space for your luggage, and can be raised again just as quickly.



The SLK boot offers ample luggage space with the roof up or down

Panoramic vario-roof (optional). As an option, the SLK is available with a panoramic vario-roof that has a transparent polycarbonate insert in the centre part of the roof. This has a fixed transparency, giving you an open-top feeling even with the roof closed.



The panoramic vario-roof guarantees an airy cabin ambience even when closed

Panoramic vario-roof with Magic Sky Control (optional). The latest SLK innovation is called Magic Sky Control. It enables the glass panoramic vario-roof to switch from transparent to tinted at the touch of a button, allowing you to choose between maximum light or effective protection from glare.





Climate control and interior lighting

The right cabin climate makes for a relaxed, alert driver and a contented passenger. Which is why the SLK lets each choose their own individual temperature settings.

Automatic climate control (standard). The climate control system automatically maintains your desired cabin temperature. It includes an air recirculation function with automatically closing windows, residual engine heat utilisation, and a combined dust and activated charcoal filter that captures particulates and improves air quality.

Luxury automatic climate control (optional). The two-zone luxury automatic climate control system maintains separate preset temperatures for each side of the cabin, compensating automatically for external influences such as sunlight, air quality and humidity in the process. By allowing driver and passenger to tailor the cabin climate to their needs, it ensures both enjoy

optimum comfort and helps the driver to stay relaxed and alert at all times.

Ambient interior lighting (optional). The Solar Red ambient interior lighting further enhances the cabin's sporty feel when driving at night. Comprising direct lighting for the centre console and door armrests plus indirect lighting for the door centre panels, it comes on as soon as you open the door then dims automatically once the door is closed. Its brightness can be adjusted, with five different settings for you to choose from. For an even wider range of lighting possibilities, ambient interior lighting can be combined with the optional Interior Lighting Package.



The automatic climate control system helps you maintain a pleasant cabin temperature in all weathers





Seats

The SLK comes with sports seats that meet the very highest standards of comfort, safety and ergonomics.

With their stylish, purposeful looks, the SLK's sports seats further emphasise the car's sporting intentions. What's more, they provide exceptional side support and stability even in fast cornering, keep you comfortable on long journeys, and help to protect you in the event of an accident.

On the standard SLK, they are upholstered in Black cloth, with optional leather or nappa leather upholstery available in a variety of different colours with contrasting top-stitching. The SLK AMG Sport comes with leather upholstery, with nappa leather optionally available. With Black or Crystal Grey upholstery the

seats have a vertical fluting design, red top-stitching to the seats and to some areas in the cabin, and red seat belts.

Memory function (part of the optional Memory Package). The memory function allows you to store driving positions for up to three different people. Each driver can then instantly call up their preferred settings for the seat and backrest position, the steering wheel and both exterior mirrors.



Electric seats with memory function





The new SLK seats combine comfort, ergonomics and sporty looks



Upholstery and trim





The Black interior scheme features either cloth upholstery in Black or leather upholstery in Black with grey top-stitching. For the SLK AMG Sport, there's leather upholstery in Black with red top-stitching. The centre console is in brushed aluminium; all other metal surfaces have an attractive chrome silver finish.

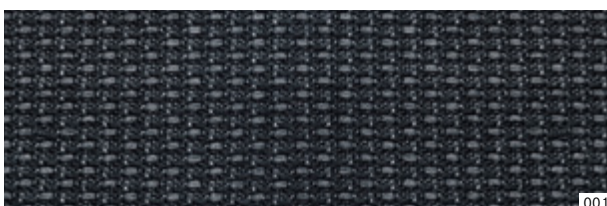

001

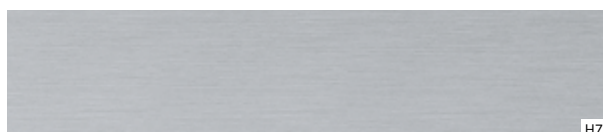

H76

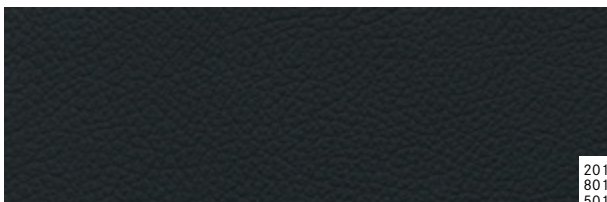
201
801
501

736



731

BLACK

- 001 Cloth (standard on SLK)
 - 201 Leather (optional¹)
 - 801 Nappa leather (optional)
 - 501 Exclusive Nappa leather (optional)
-

TRIM

- H76 Brushed aluminium
 - 736 Black Ash (optional)
 - 731 Dark Burr Walnut (optional on SLK only)
-

¹Standard on SLK AMG Sport



The Crystal Grey interior scheme features leather upholstery in Crystal Grey with black top-stitching (red top-stitching for the SLK AMG Sport). The centre console is in brushed aluminium; all other metal surfaces have an attractive chrome silver finish.

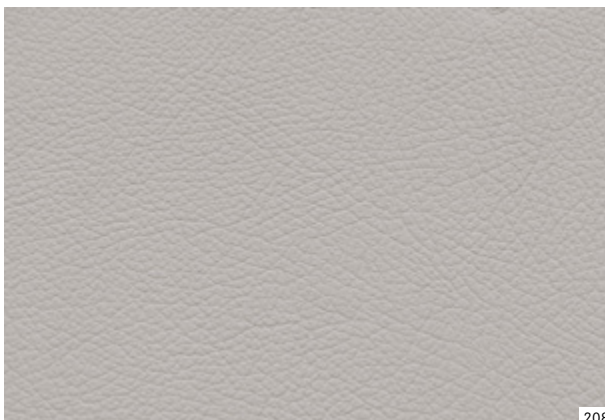

208



H76



736



731

CRYSTAL GREY

208 Leather (optional¹)

TRIM

H76 Brushed aluminium

736 Black Ash (optional)

731 Dark Burr Walnut (optional on SLK only)

¹Standard on SLK AMG Sport



The Sahara Beige interior scheme features leather upholstery in Sahara Beige with black top-stitching. The centre console is in brushed aluminium; all other metal surfaces have an attractive chrome silver finish.

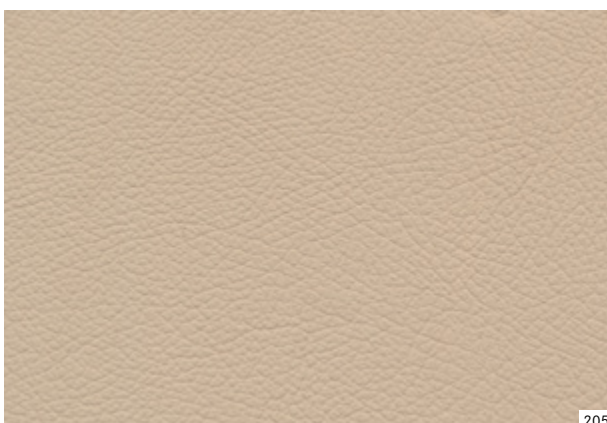

205

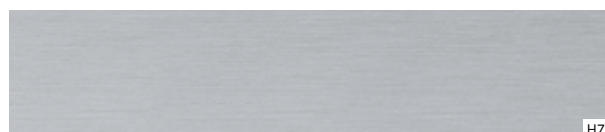

H76



736



731

SAHARA BEIGE

205 Leather (optional¹)

TRIM

H76 Brushed aluminium

736 Black Ash (optional)

731 Dark Burr Walnut (optional on SLK only)

¹Standard on SLK AMG Sport

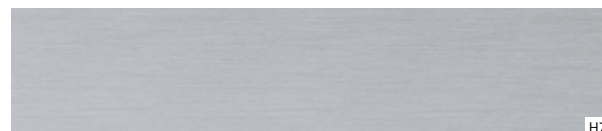

The Bengal Red colour scheme features either nappa leather or Exclusive Nappa leather upholstery in Bengal Red with black top-stitching. The centre console is in brushed aluminium; all other metal surfaces have an attractive chrome silver finish.

807
507

H76



736



731

BENGAL RED

807 Nappa leather (optional)

507 Exclusive Nappa leather (optional)

TRIM

H76 Brushed aluminium

736 Black Ash (optional)

731 Dark Burr Walnut (optional on SLK only)



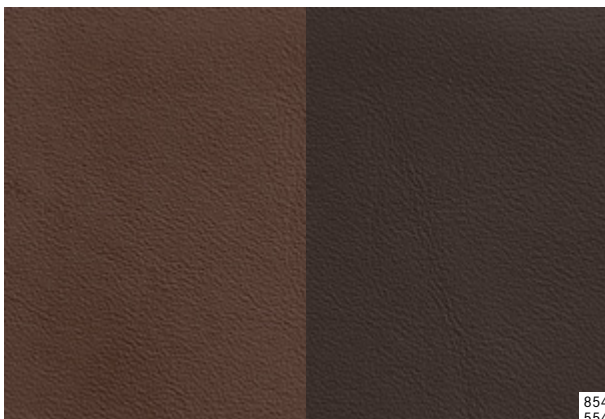

The Nut Brown/Mocha Brown interior scheme features two-tone leather upholstery with Nut Brown seat facings, Mocha Brown side bolsters and top-stitching in contrasting Havanna. The centre console is in brushed aluminium; all other metal surfaces have an attractive chrome silver finish.

854
554

H76



736



731

NUT BROWN/MOCHA BROWN

854 Nappa leather (optional)

554 Exclusive Nappa leather (optional)

TRIM

H76 Brushed aluminium

736 Black Ash (optional)

731 Dark Burr Walnut (optional on SLK only)



SLK AMG Sport

Muscular, eye-catching and exceptionally agile, the SLK AMG Sport comes with added excitement as standard.

With AMG bodystyling – front, rear aprons and side skirts – the SLK AMG Sport is a roadster that always sets the pulse racing. Its headlamps with dark surrounds and dark tinted tail lights lend an even more eye-catching look, and there are also striking 18" AMG alloy wheels as standard.

What's more, the SLK AMG Sport delivers extra driving thrills too, thanks to 10 mm lower sports suspension, along with cross-drilled brake discs and 'Mercedes-Benz' lettering on the front calipers.



The SLK AMG Sport's eye-catching rear apron



18" AMG 5-spoke alloy wheels





The SLK AMG Sport offers added exclusivity and athleticism



SLK AMG Sport interior

With its purposeful yet luxurious cabin, the SLK AMG Sport is a joy for driver and passenger alike.



Multi-function sports steering wheel with perforated leather trim and red top-stitching



Instrument backplate in chequered flag design

The exclusive SLK AMG Sport interior boasts eye-catching details such as red seat belts (Black or Crystal Grey upholstery only), AMG floor mats, and an instrument panel with a chequered flag backplate. There's also vertically fluted leather upholstery, with red top-stitching for the seats, armrests, steering wheel and gear shift gaiter (Black or Crystal Grey upholstery only). The sports steering wheel also features perforated leather trim in the grip area (Black or Crystal Grey upholstery only) plus steering wheel shift paddles for automatic models.





The SLK AMG Sport interior combines exclusive luxury with eye-catching details



designo

For an even more individual SLK, choose from the range of *designo* paint finishes, upholstery and trim. → www.mercedes-benz.co.uk/designo

The *designo* options for the SLK combine the highest standards of quality and craftsmanship with exclusive colours and designs. Select from the range of 11 single- and two-tone leather upholsteries for the seats and door centre panels. Then add matching leather interior trim in either *designo* Black or your chosen *designo* upholstery colour. Sporty AMG Carbon and refined Black Piano Lacquer trim options are also available, along with red or silver seat belts and an Anthracite Alcantara® windscreen surround.

For the exterior, there's a choice of five *designo* special paint finishes, including two distinctive matt finishes.



designo Black Piano Lacquer interior trim (code W69)





Standard equipment | Selection



Attention Assist



Electric parking brake



Clear-lens headlamps and LED daytime running lights



Automatic climate control



LED tail lights



Vario-roof





Audio 20 radio with integrated 6-disc CD changer



Ergonomic sports seats



Multi-function sports steering wheel with flattened lower section



USB port and aux-in socket in the centre console



Stainless steel door sill panels



Roof controls and central controller



Optional extras | Selection



Panoramic vario-roof with or without Magic Sky Control



Becker® Map Pilot navigation system for Audio 20 radio



Intelligent Light System



Ambient interior lighting



Exclusive Nappa Leather



Harman Kardon® Logic 7® surround sound system





Airguide wind deflector, comprising twin Plexiglas® panels



Airscafc neck-level heating



COMAND Online multimedia system



Electric seat adjustment with memory function



Analogue clock



Alloy wheels



17" 5-spoke alloy wheels (standard on SLK, code 37R)



18" 5-spoke alloy wheels (optional on SLK, code R32)



18" AMG 5-spoke alloy wheels, burnished finish (standard on SLK AMG Sport, code 782)



17" 10-spoke alloy wheels (optional on SLK, code R35)



18" 5-twin-spoke alloy wheels, burnished two-tone Palladium Silver finish (optional on SLK, code 22R)



17" incenio 10-spoke alloy wheels, burnished two-tone Palladium Silver finish (Retailer-fit accessory)



Retailer-fit accessories

Custom-designed for the new SLK, our Retailer-fit accessories are the perfect way to make your roadster even sportier and more practical.

Our Retailer-fit accessories range includes a variety of styling enhancements that further emphasise your SLK's striking lines – such as a MercedesSport rear spoiler, chromed fins for the bonnet vents and alloy wheels in a variety of styles and sizes.



Chromed fins for the bonnet vents

Also available are useful extras such as a non-slip boot tray. Its raised edges fit neatly against the sides of the boot, while the ribbed surface helps to prevent luggage from sliding around in the boot.



Non-slip boot tray

For more details about these and other SLK accessories, please see the relevant brochure or talk to your local Mercedes-Benz Retailer.



Eye-catching MercedesSport rear spoiler with Retailer-fit accessory wheels



Services

Mercedes-Benz World at Brooklands. Celebrate the story of Mercedes-Benz and you'll celebrate the story of motoring itself at Mercedes-Benz World in Surrey. A World of experiences. A World of discoveries. A World you will love to explore. Discover Mercedes-Benz racing heritage, its connections to the famous Brooklands circuit and to legendary drivers. View, touch and sit in every car from the Mercedes-Benz range, and encounter automotive legends like the 'Gullwing', in the UK's largest Mercedes-Benz showcase. Then set your pulse racing by booking one of our thrilling Driving Experiences. Enjoy AMG performance on the purpose-built Handling Circuits or Wet Skid Circle, an axle-twisting off-road adventure, or treat your kids to their own drive in an A-Class if they are over 1.5 metres tall. For more interactive action, take a virtual journey along the production line in 'Build' or take a seat in the cinema and accelerate from the birth of the car to the latest innovations in 20 eye-opening minutes.

Relax and refuel in Café 1886, or for a gourmet treat enjoy the first-class menu and elegant surroundings of the Gullwing Restaurant. Finally, extend your visit with a short stroll to Brooklands Museum to see their collection of classic cars, aviation exhibitions – and the legendary Concorde. For more information visit www.mercedes-benzworld.co.uk

Mercedes-Benz Museum. More than 120 years of automotive history in one place – the Mercedes-Benz Museum in Stuttgart-Untertürkheim. With a total exhibition area of 16,500 m², it transports the visitor into a fascinating world of automotive achievement. You can see the first modern motor car, the Mercedes Simplex, discover over 100 years of motor-racing history, and, of course, admire our classics, such as the 'Gullwing' and the 'Tail Fin'. Legendary cars such as these have always occupied a special place in the hearts of car enthusiasts. Now they have a special place of their own in the Mercedes-Benz Museum. We look forward to welcoming you there soon. For more information visit www.mercedes-benz-classic.com/museum

Roadside Assistance. Rest assured that should you ever need help, Mercedes-Benz Roadside Assistance is there for you. In the unlikely event of a technical breakdown¹ you can rely on the Mercedes-Benz Roadside Assistance Team – anywhere in Europe. Simply phone our Customer Assistance Centre on 00800 1 777 7777,² where our specialists will organise assistance for you. Mercedes-Benz will also assist you in the event of a minor mishap preventing you from driving your vehicle.³ Whether you lose your key, run out of fuel or your vehicle is damaged due to an accident or vandalism, Mercedes-Benz ensures that you still reach your destination. Often the problem can be rectified on the spot, but if this is not possible, we will naturally ensure that your vehicle is taken to the nearest Mercedes-Benz Official Workshop to get you back on the road as quickly as possible.



Mercedes-Benz Finance. At Mercedes-Benz Finance, our single-minded aim is to provide optimum financial solutions for all those who share the Mercedes-Benz philosophy of absolute commitment to quality. Whether you are a private customer or a business user, our finance and leasing packages can be tailored to meet your individual needs. For further information on Mercedes-Benz Finance, please contact your local Mercedes-Benz Retailer.

Mercedes-Benz Insurance offers a fully comprehensive 5 star⁴ motor insurance policy specifically designed to give you the cover you would expect from Mercedes-Benz. For a quotation, please call 0845 600 2180.⁵

Test drive. A Mercedes-Benz is most at home on the road. This is the only way to experience the effortlessly superior driving feel that lends every Mercedes model its inimitable class. Feel the power of efficient engines with low fuel consumption, and precise steering designed to put you in the mood for driving. And experience what true comfort really feels like. The unique feeling of driving a Mercedes cannot be put into words, however. Which is precisely why we'd like to invite you to take a test drive. Your Mercedes-Benz Retailer will be happy to make all the necessary arrangements for you. Simply visit www.mercedes-benz.co.uk/testdrive to request a test drive. We look forward to seeing you.

Interactive Owner's Manual. The website also offers an interactive tour, enabling you to take a closer look at your desired model. This simulation is the ideal way to acquaint yourself with your dream car. You can view key functions in detail, gain an insight into the car's inner workings or look at the benefits of each model. For further details, visit www.mercedes-benz.co.uk/slkclassmanual



¹ Technical breakdown cover is initially valid for your vehicle for four years from the date of first registration. This can be extended from the fifth year, up to a maximum of 30 years, on completion of each scheduled maintenance service, providing that this service is carried out by a Mercedes-Benz Official Workshop

² In non-affiliated European countries: +44 20 7975 7077

³ This cover can be retained from the fifth year. Your Mercedes-Benz Official Workshop will provide details of how to renew this cover once your initial four year term has expired

⁴ As rated 5 by Defaqto, a leading independent financial research company. Mercedes-Benz Motor Insurance is underwritten by Aviva Insurance UK Limited
⁵ Calls are charged at local rate and may be recorded



Dimensions

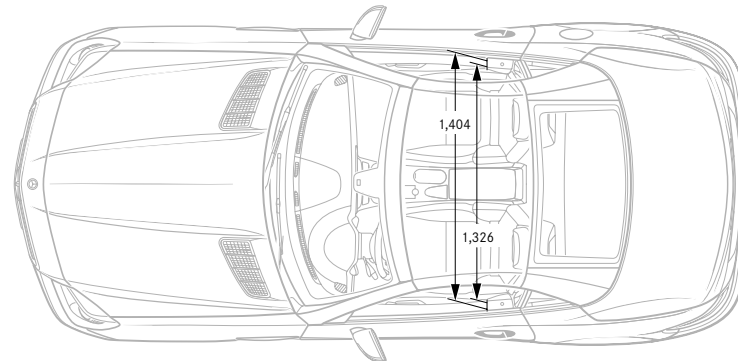
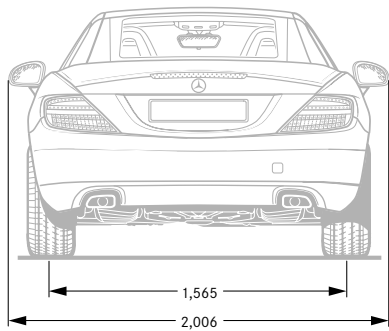
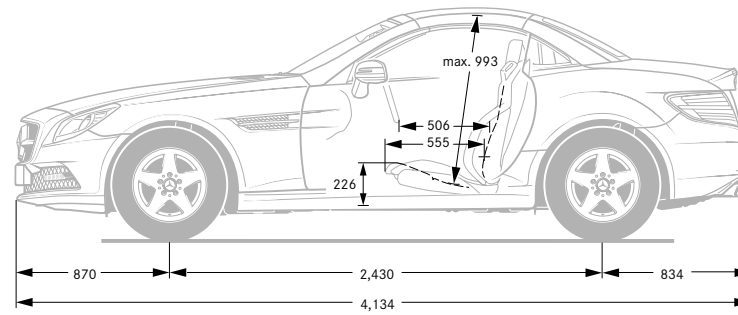
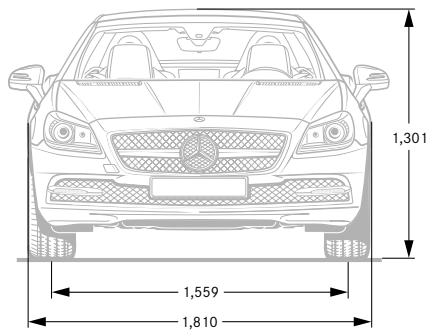

All measurements in millimeters. The dimensions shown are mean values and apply to standard-specification, unladen vehicles



Technical data

PETROL ENGINES	SLK 200 BlueEFFICIENCY	SLK 250 BlueEFFICIENCY ¹	SLK 350 BlueEFFICIENCY
Total displacement – cc	1,796	1,796	3,498
Rated output ² – hp (kW) at rpm	184 (135)/5,250	204 (150)/5,500	306 (225)/6,500
Acceleration 0–62 mph – sec (auto.)	7.3 (7.0)	– (6.6)	– (5.6)
Top speed, approx. – mph (auto.)	149 (147)	– (151)	– (155) ³
Fuel consumption ⁴ – mpg (auto.)			
Urban	30.4 (32.8)	– (32.5)	– (28.5)
Extra-urban	53.3 (53.3)	– (52.3)	– (51.4)
Combined	41.5 (43.5)	– (42.8)	– (39.8)
CO ₂ emissions, combined ⁴ – g/km (auto.)	149–158 (142–151)	– (153)	– (167)
EU emissions standard	Euro 5	Euro 5	Euro 5
Fuel tank capacity/reserve (approx.) – l	60/8	60/8	60/8
Boot capacity – l			
with roof closed	335	335	335
with roof open	225	225	225
Turning circle – m	10.52	10.52	10.52
Kerb weight ⁵ – kg (auto.)	1,435 (1,470)	– (1,500)	– (1,540)
Perm. GVW – kg (auto.)	1,750 (1,785)	– (1,815)	– (1,855)

¹Manual transmission for SLK 250 BlueEFFICIENCY available from fourth quarter 2011 ²Figures according to Directive 80/1269/EEC in the currently applicable version ³Electronically limited ⁴The figures shown were obtained in accordance with the prescribed measuring process (Directive 80/1268/EEC in the currently applicable version). The figures are not based on an individual vehicle and do not constitute part of the product offer; they are provided solely for purposes of comparison between different vehicle models

⁵Figures according to Directive 92/21/EC, version 95/48/EC (kerb weight with fuel tank 90% full, driver, 68 kg, and luggage, 7 kg) for standard-specification vehicles. Optional extras and accessories will generally increase this figure and reduce the payload capacity accordingly

Paint finishes

NON-METALLIC PAINTS



040

METALLIC PAINTS¹



197



792



890

NON-METALLIC PAINTS

040 Black

590 Fire Opal

METALLIC PAINTS¹

197 Obsidian Black

755 Tenorite Grey

775 Iridium Silver

792 Palladium Silver

794 Pearl Beige

799 Diamond White

890 Cavansite Blue

963 Indium Grey

967 Galenite Silver

designo SPECIAL PAINT¹

057 Zircon Red

Other *designo* paint finishes are also available



590



755



794



963

designo SPECIAL PAINT¹



057



775



799



967

¹Optional



Take-back of end-of-life vehicles. Coming full circle. At the end of its long life, you can return your SLK-Class to us for environment-friendly disposal in accordance with the EC End-of-Life Vehicle Directive.¹ But that day lies a long way off.

¹Applies in accordance with national regulations to vehicles up to 3.5 tonnes gross weight. The SLK-Class has met the statutory regulations governing the suitability of the vehicle's design for reuse and recycling for a number of years now. A network of vehicle take-back depots and dismantlers has been established which will process your vehicle in an environment-friendly manner. The ways in which both vehicles and parts can be recovered are subject to ongoing development and improvement. Consequently, the SLK-Class will be able to comply with any future increases in the recycling quota within the stipulated time limits. Further information is available at www.mercedes-benz.co.uk or by calling 00800 1 777 7777.

Please note: this online version of the printed brochure may contain abridged copy or other content changes. The manufacturer reserves the right to make changes to the design, form, colour and specification during the delivery period, provided these changes, while taking into account the interests of the vendor, can be deemed reasonable with respect to the purchaser. Where the vendor or the manufacturer uses symbols or numbers to describe an order or the subject of an order, no rights may be derived solely from these. The illustrations may show accessories and items of optional equipment which are not part of standard specification. Colours may differ slightly from those shown. This brochure provides a general indication of the range of models, features, optional extras and/or colours available in various countries. Some of the models, features, optional extras and/or colours shown may not be available in your country or may only be available in a different specification. Additionally, some models, features, optional extras and/or colours may only be available in combination with others. For current and more specific information in relation to the range of models, features, optional extras and/or colours available in your country, and their pricing, you should contact your nearest authorised Mercedes-Benz Retailer. E&OE.

