

DETAILS.



BE MINI.

MINI COUNTRYMAN.

MINI COUNTRYMAN.

MINI IN DETAIL.



1. MODELS

06



2. CONCEPT AND SAFETY

08



3. COLOURS AND UPHOLSTERY

14



4. EXTERIOR DESIGN AND WHEELS

20



5. INTERIOR DESIGN

26



6. MUSIC, COMMUNICATIONS AND TECHNOLOGY

32



7. PERFORMANCE

40



8. GENUINE MINI ACCESSORIES

42

MINI DATA.

Technical data

44

Dimensional drawings

46

[MINI.CO.UK/CONFIGURATOR](https://www.mini.co.uk/configurator)

This link will take you straight to the online MINI Configurator.

EIGHT STEPS TO YOUR VERY OWN MINI COUNTRYMAN.

MINI One/D Countryman, MINI Cooper/D Countryman, MINI Cooper S/SD Countryman: whichever model you want, this brochure will help you put your very own MINI Countryman together. The symbols at the top of the page will guide you through the process in eight easy steps. Step one is to choose the model you're interested in. In step two you can find out all about the MINI concept, technology and comprehensive safety features. Steps three, four and five are where you can give your MINI Countryman a distinctive look and feel. What exterior colour will you choose? What seats, upholstery and wheels? In step six, you can equip it with all the information and entertainment systems you want, like the MINI Radio Visual BOOST and MINI Connected. And steps seven and eight, performance and accessories, add the finishing touches.



AS MANY RIGHT ANSWERS AS THERE ARE DRIVERS.

There's a MINI Countryman to suit everyone, the big question is, which one is for you? Every model is available in front-wheel drive from the frugal MINI One D to the responsive MINI Cooper S.

For freedom to explore the wider world there's the MINI Cooper D ALL4, Cooper S ALL4, or Cooper SD ALL4 models fitted with all-wheel drive.

Decisions, decisions, decisions.







1. MODELS.



MINI ONE COUNTRYMAN MINI ONE D COUNTRYMAN

The MINI One Countryman models are far from being poor relatives...
• Both models have extremely capable engines and drive in the typical MINI way - go kart handling at your finger tips.

- Chrome grille with matt black bars
- Matt silver side scuttles
- Matt black mirror caps
- Body colour roof (contrast not available)
- Roof rails in matt silver
- Orange indicators
- 16" Steel wheels¹
- Exhaust tailpipe trim in chrome



MINI COOPER COUNTRYMAN MINI COOPER D COUNTRYMAN MINI COOPER D ALL4 COUNTRYMAN

The MINI Cooper Countryman models take the model range to the next level with more powerful engines and enhanced customisation possibilities...

- Chrome grille with matt silver bars
- Matt silver side scuttles
- Body coloured mirror caps (unless contrast roof is specified)
- Body or Contrast roof colour available
- Roof rails in matt silver
- Orange indicators
- 16" 5-Star Single Spoke alloy wheels¹
- Exhaust tailpipe trim in chrome



MINI COOPER S COUNTRYMAN MINI COOPER SD COUNTRYMAN MINI COOPER S ALL4 COUNTRYMAN MINI COOPER SD ALL4 COUNTRYMAN

The MINI Cooper S Countryman models complete the model range offering strong performance and a unique exterior design...

- Chrome grille surround with hexagonal black grille
- Dark anthracite side scuttles with 'S' badge and white indicators
- Cooper S front bumper with central air intake and twin lower brake air cooling intakes
- Cooper S rear bumper with diffuser
- Body coloured mirror caps (unless contrast roof is specified)
- Body or Contrast roof colour available
- Roof rails in Dark Anthracite
- Roof spoiler in roof colour
- 17" 5-Star Double Spoke alloy wheels¹
- Twin exhaust tailpipes in chrome

¹ Images shown feature optional alloy wheels. Please see pages 24-25 for full details on standard and optional wheels available.





2. CONCEPT AND SAFETY.

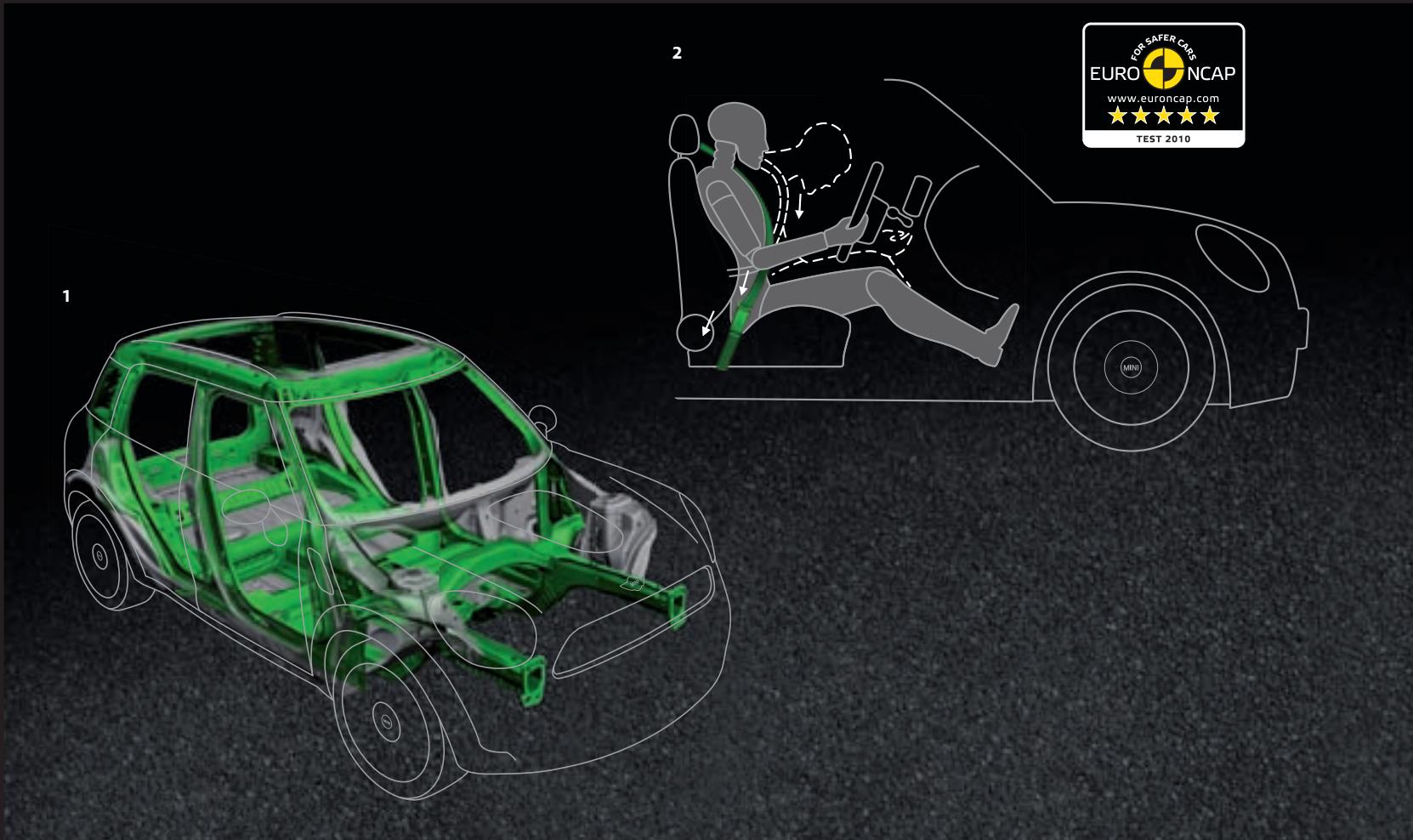

1. BODY. The body of the MINI Countryman has been reinforced at strategic points, guaranteeing extreme torsional rigidity for an exceedingly robust passenger compartment. The aim is to deliver the perfect combination of comfort, acoustics and protection.

SUSPENSION. The combination of a single-link spring-strut front axle and a multi-link rear axle with wide track and a low centre of gravity results in the unmistakable MINI feeling: stable, agile, with excellent cornering ability at all speeds, plus superb traction and outstanding safety.

2. RESTRAINT SYSTEM. A combination of 3-point belts, belt tensioners and belt force limiters means driver and front-seat passenger enjoy the best possible protection in the event of a crash.

ISOFIX. To ensure the safety of younger passengers, one or two ISOFIX child seats can be mounted in the rear as standard.

EURO NCAP CRASH TEST. In the Euro NCAP crash test, the MINI Countryman scored five stars. The level of protection for the occupants was rated as excellent in front, side and pole impacts, and the car also received outstanding scores for child safety.

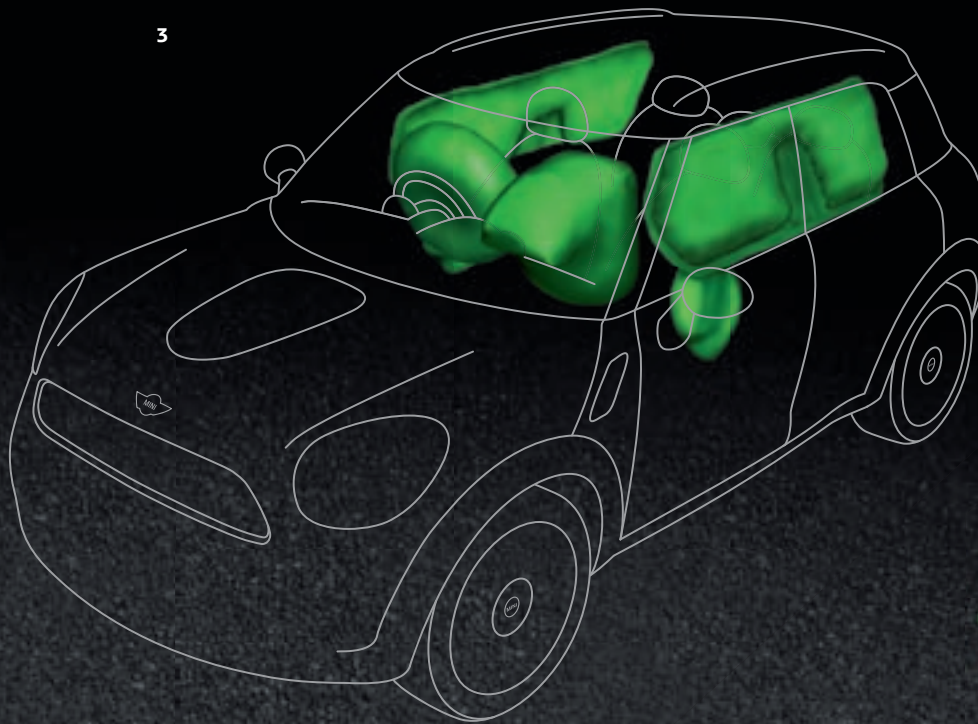

3. AIRBAGS. The MINI Countryman is fitted with six airbags as standard: driver and front passenger airbags protect the head and upper body in the event of a head-on collision, while side and head airbags are primarily designed to reduce the risk of injuries to the head, chest and abdominal areas from side impacts.

4. BRAKING SYSTEM. Four disc brakes with Anti-lock Braking System (ABS), Cornering Brake Control (CBC) and Electronic Brake Force Distribution (EBD) as standard ensure optimum braking performance. Brake Assist accelerates the delivery of braking force in an emergency situation to ensure the shortest possible distances.

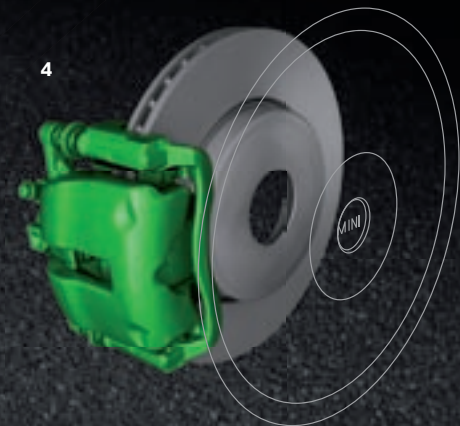

DYNAMIC BRAKE LIGHTS. Alert following drivers to dangerous situations faster. Under normal braking the light comes on in the conventional way, but when the car performs an emergency braking manoeuvre, it starts to flash. In this way, it enables the traffic behind to see straight away how hard you are braking. Automatic activation of the hazard warning lights also helps to lessen the risk of an impact from behind.

OVERBOOST FUNCTION. Performance can be a safety feature in itself. The MINI CooperS Countryman can get a temporary boost in its maximum torque from 240 to 260 newton-metres, thanks to a system that momentarily increases the turbo pressure and the quantity of fuel injected in its 1.6-litre twin-scroll turbocharged engine. And more power means overtaking distances are shorter, and therefore safer.



2. CONCEPT AND SAFETY.

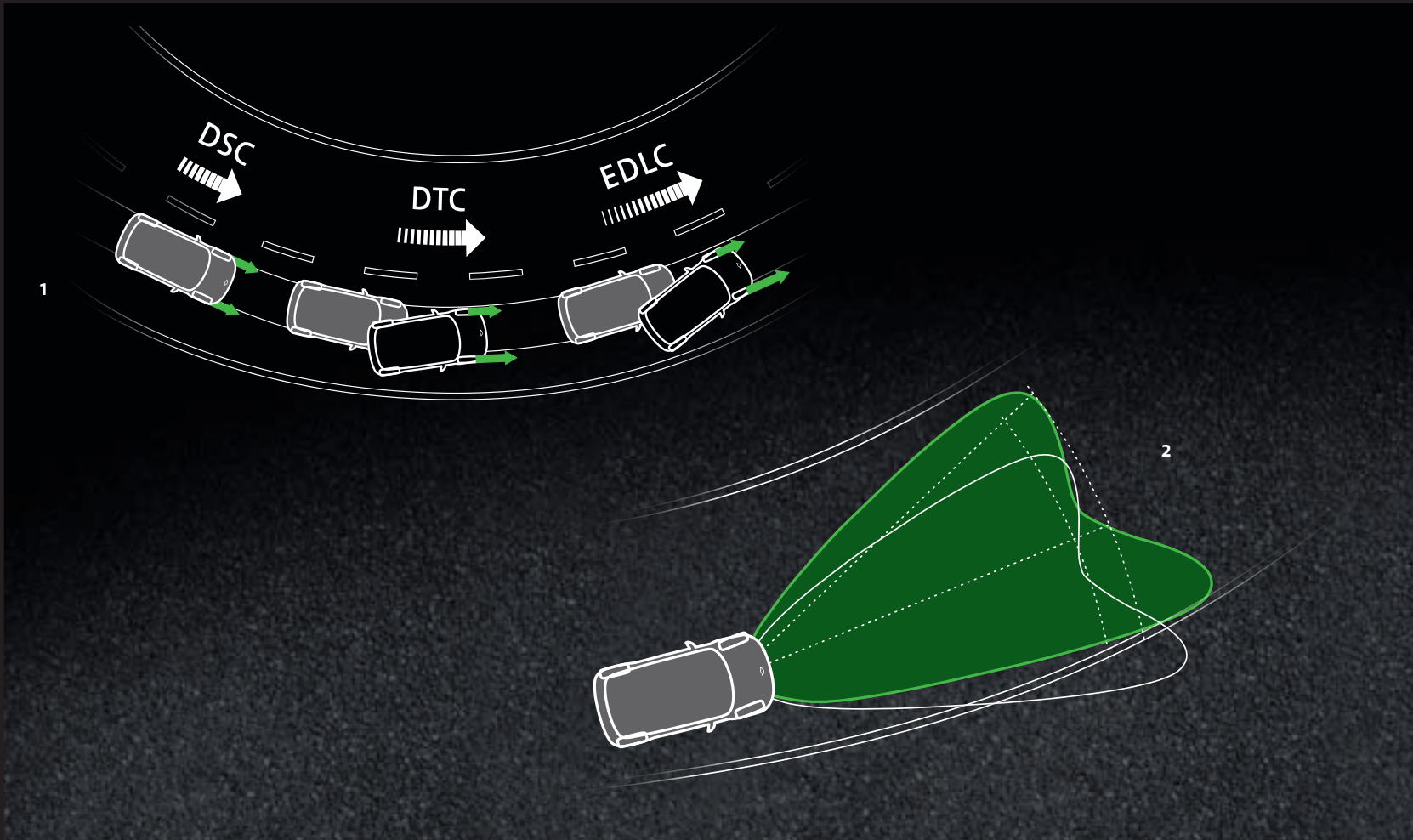

1. DSC. Fitted as standard, Dynamic Stability Control ensures optimum traction by intervening in the engine management and applying braking force to individual wheels as necessary. DSC also includes Hill Assist, which prevents the car from rolling backwards on slopes.

DTC. The optional Dynamic Traction Control system raises the threshold before intervention in the engine management and braking system. It also includes EDLC, Electronic Differential Lock Control which helps to provide selective brake-force to either front wheel (e.g. to prevent the “inside” wheel from slipping during cornering). DTC is standard for the MINI Cooper D ALL4 Countryman, MINI Cooper S Countryman, MINI Cooper S ALL4 Countryman, MINI Cooper SD Countryman and MINI Cooper SD ALL4 Countryman.

2. ADAPTIVE HEADLIGHTS. This option, featuring automatic headlight beam-throw control, ensures optimum illumination whether driving in city or country, and allows drivers to see further ahead on the motorway. Sensors measure the steering angle, rate of turn and vehicle speed, and electric motors then adjust the position of the light beam accordingly to suit the speed and direction of the car (only available in conjunction with Vision Pack).

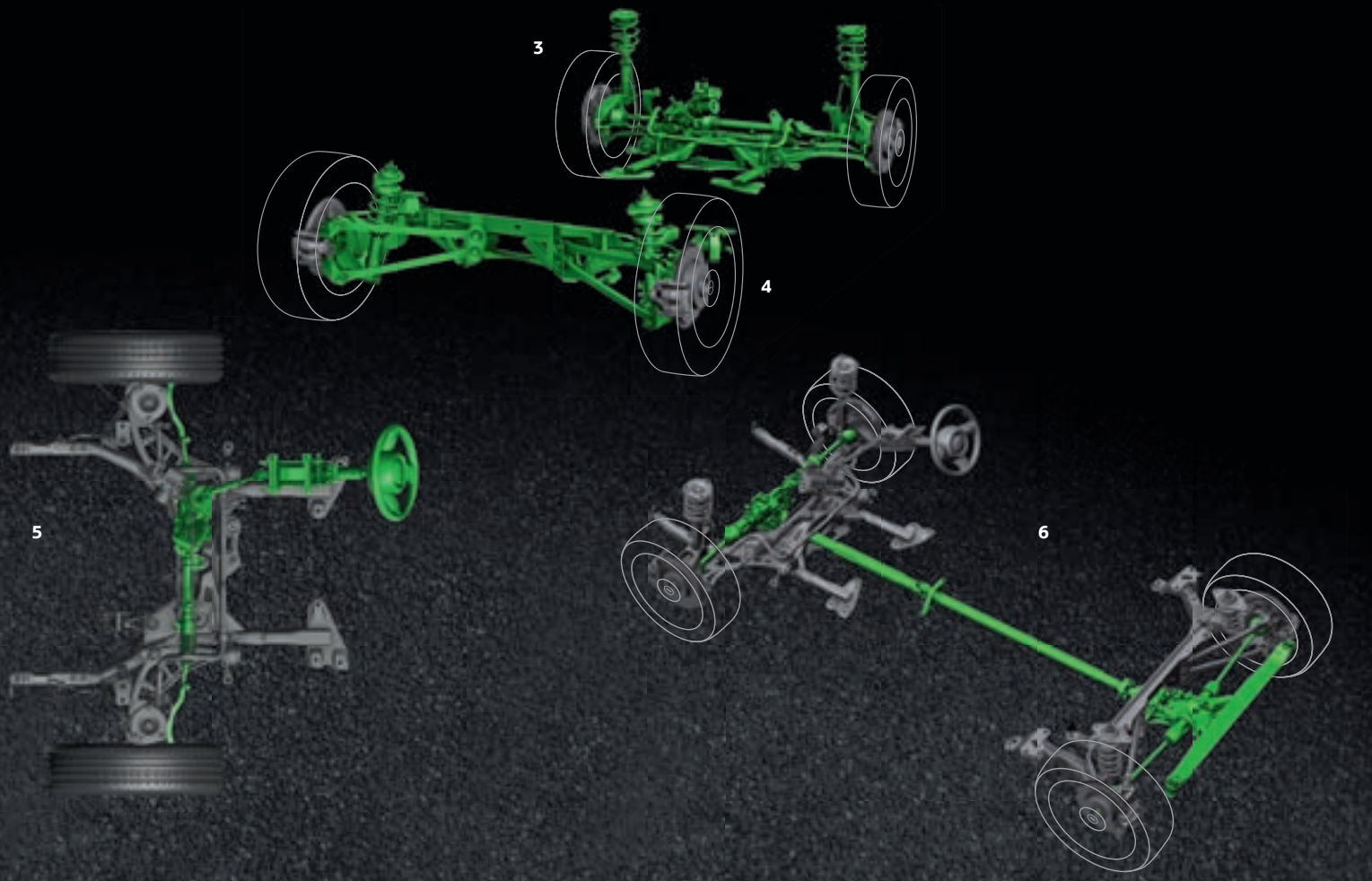

3. SINGLE-LINK SPRING-STRUT FRONT AXLE. Two drive shafts of equal length in the front suspension minimise the extent to which the drivetrain interferes with the steering, and optimise the car's cornering, acceleration and braking.

4. MULTI-LINK REAR AXLE. Unique in a car of this class, ensuring optimum contact between the wheels and the road, for the best possible traction. The aluminium construction keeps weight to a minimum and increases agility of your MINI Countryman.

5. RACK-AND-PINION STEERING. Electric power-assist ensures outstanding steering response, with the driver getting precise feedback. The weight of the steering adjusts to the speed of the car, for easier steering at low and high speeds alike. For maximum comfort it's only 2.4 turns lock to lock.

6. ALL4. The ALL4 all-wheel drive system distributes the power from the engine between front and rear axles depending on the level of grip or driving style. Under normal driving situations power is directed to the front wheels, however when ALL4 is required a multi-disc clutch can direct up to 100 percent of the engine torque to the rear axle – for instance when driving on snow or ice. The result is optimum traction, grip and safety at all times whilst aiding fuel economy by only utilising ALL4 when required.



2. CONCEPT AND SAFETY.

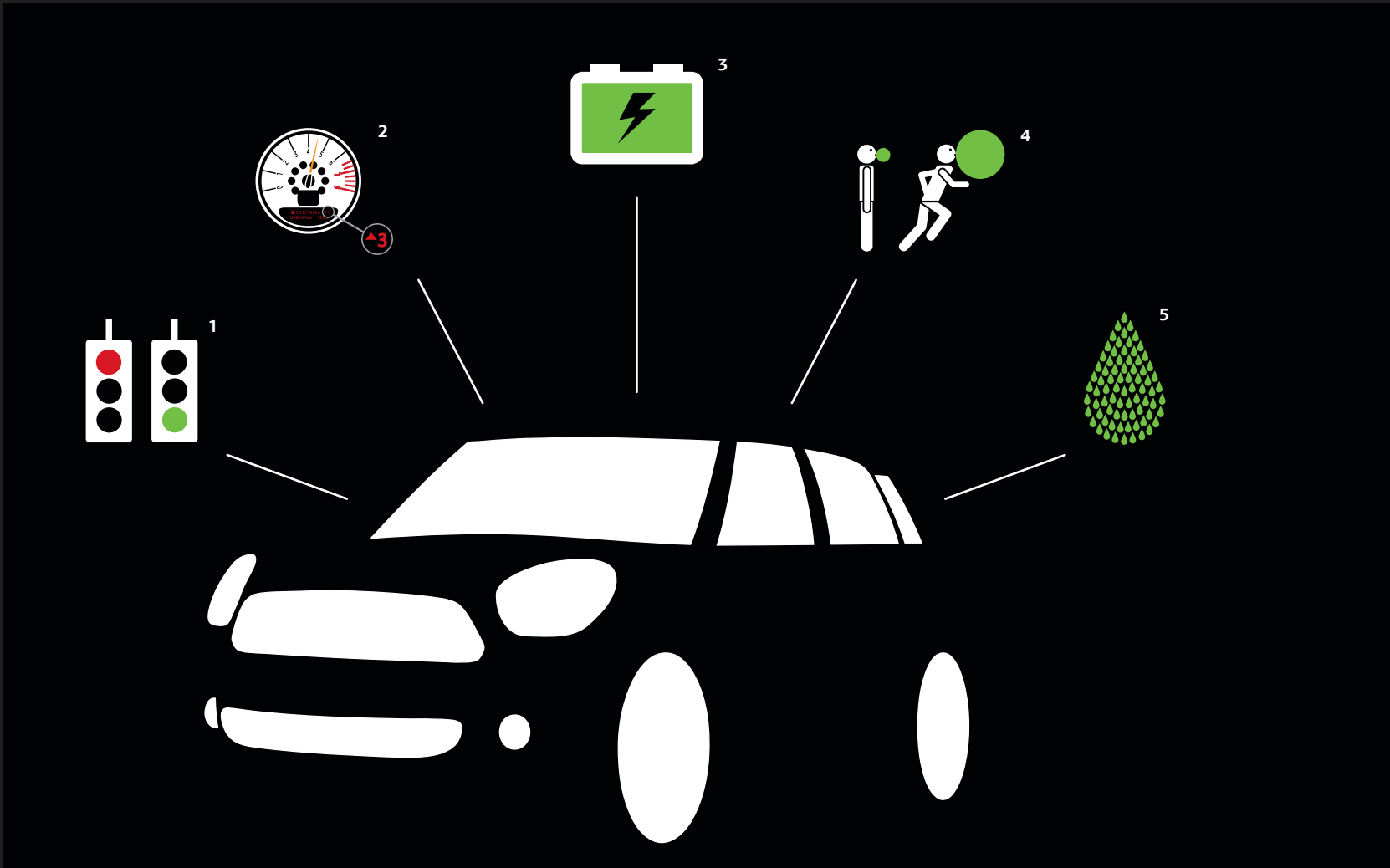

MINIMALISM. LESS IS MORE.

Cutting out the fumes needn't mean cutting out the fun. This is made possible by a range of innovative MINIMALISM technologies fitted to all MINI Countryman models.

1. AUTOMATIC START-STOP FUNCTION. Manual gearbox only. With the car in neutral and the clutch disengaged, the engine is automatically switched off. As soon as the clutch pedal is depressed, the engine is restarted, giving you a unique fuel saving feature.

2. SHIFT POINT DISPLAY. The Shift Point Display (manual gearbox only) informs you of the most economical gear for any given situation, helping to reduce your emissions and expenditure on fuel.

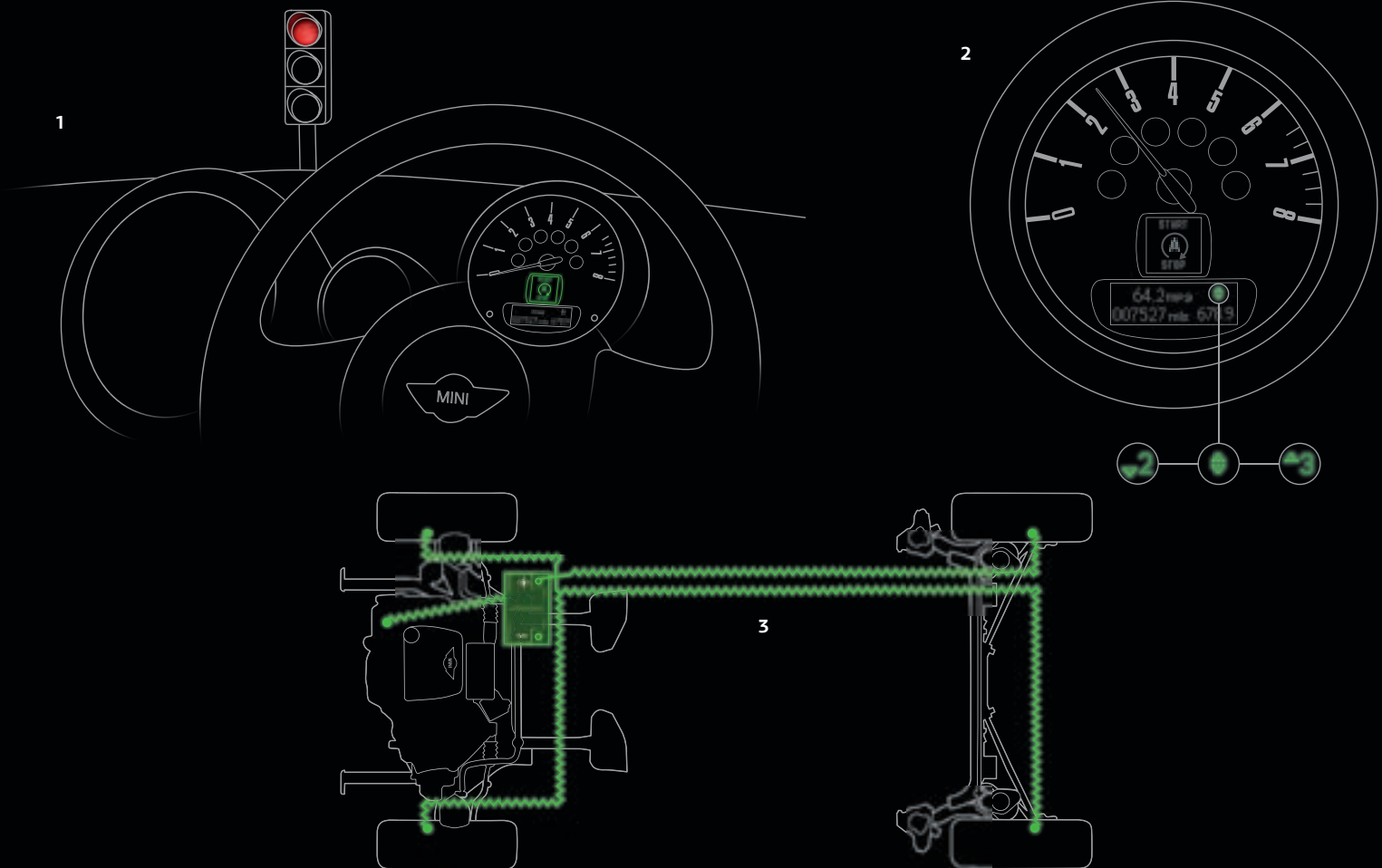

3. BRAKE ENERGY REGENERATION. Brake Energy Regeneration uses Intelligent Alternator Control to make the most of unused energy. When coasting or braking, the battery is charged, utilising energy that would otherwise be wasted.

4. FULLY VARIABLE VALVE TIMING. Cutting edge technology increases power output while simultaneously improving the efficiency of combustion. On all models with petrol engines.

5. COMMON-RAIL TECHNOLOGY. High-pressure injection and multiple pre-injections ensure the diesel enters the cylinder as a fine mist, which reduces engine noise and improves both power and fuel economy.

The **MINIMALISM ANALYSER.** Part of the optional MINI Connected infotainment system, the MINIMALISM Analyser monitors a number of variables to determine how economically you are currently driving, and gives you advice on how you could use less fuel. After each journey, you can review and compare your driving data with the user-friendly MINI Connected application, and refine your driving style for even greater fuel-efficiency.

¹ For more information on MINI Connected, see pages 32–35.



3. COLOURS AND UPHOLSTERY.

EXTERIOR COLOURS.

A wide range of exclusive metallic and non-metallic paint colours are available for your MINI Countryman. Give your MINI the personal touch by combining different colour options for the roof, exterior mirror caps and wheels.

MINI One/D Countryman:

- Roof in Body Colour and exterior mirror caps in Matt Black.

MINI Cooper/D Countryman and

MINI Cooper S/SD Countryman:

- Roof and exterior mirror caps in body colour as standard.
- Roof and exterior mirror caps in Black as an option.
- Roof and exterior mirror caps in White as an option.

Depending on the model and the wheel design chosen, wheels are available in up to four different colours.

NON-METALLIC COLOURS.¹

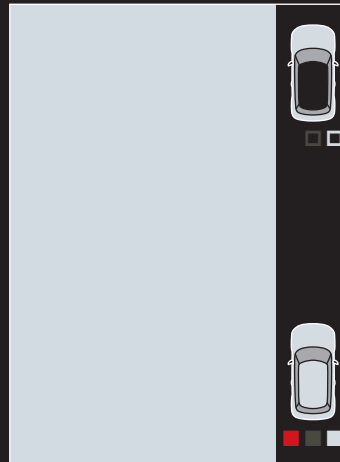

B15
Light White

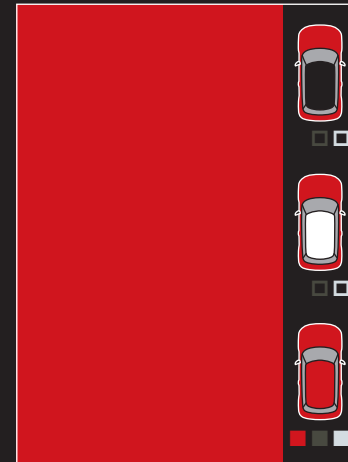

B16
Pure Red

[MINI.CO.UK/CONFIGURATOR](https://www.mini.co.uk/configurator)

METALLIC COLOURS.¹



B26
Oxford Green

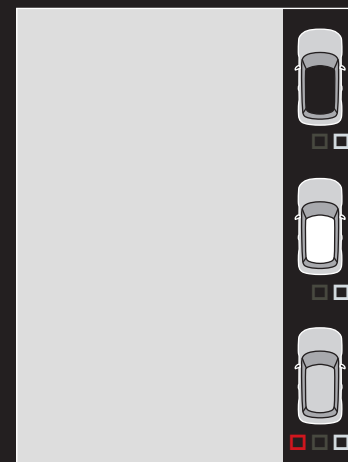

B12
Crystal Silver

¹ With available roof colours for each.

Standard on
■ MINI One/D Countryman
■ MINI Cooper/D Countryman
■ MINI Cooper S/SD Countryman

Optional on
□ MINI One/D Countryman
□ MINI Cooper/D Countryman
□ MINI Cooper S/SD Countryman

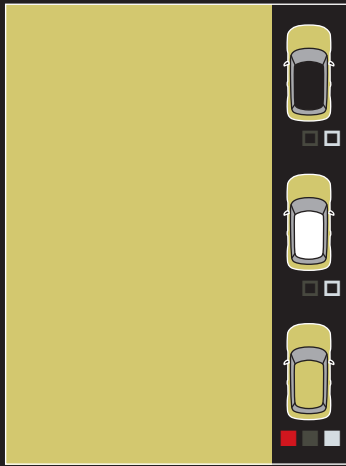

B17
Bright Yellow



B19
Light Coffee



B18
Surf Blue

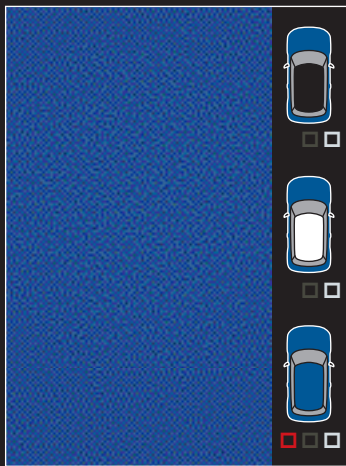

B14
True Blue



B11
Absolute Black



A48
Royal Grey



B13
Cosmic Blue



3. COLOURS AND UPHOLSTERY.

INTERIOR AND COCKPIT TRIM.

The interior trim in the MINI Countryman can be broken down into three main areas:

- Door ellipse and downtubes: on the MINI One/D and MINI Cooper/D Countryman, the downtubes on the side of the centre console and the elliptical door rings come in Black as standard and can be upgraded to Dark Silver or Piano Black. On the MINI Cooper S/SD Countryman they come as standard in an elegant Dark Anthracite, with Piano Black available as an option.
- Dashboard trim: Dark Silver, Dark Anthracite and Piano Black can also be specified for the dashboard trim (the decorative trim above the glovebox and behind the steering wheel).
- Final touches: colour accents around the central speedometer, dashboard air vents and the gear lever are finished in Dark Grey, or in Anthracite on the MINI Cooper S/SD Countryman.



Illustration shows standard equipment. ■ ■



Illustration shows door ellipse and downtubes and dashboard trim in Dark Silver, with colour accents in Dark Grey.

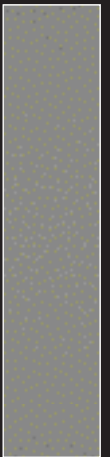

4DB
Dark Silver
■ ■



Illustration shows door ellipse and downtubes and optional dashboard trim in Dark Anthracite, with colour accents in Anthracite.



Dark
Anthracite
■



Illustration shows door ellipse and downtubes and dashboard trim in Piano Black, with colour accents in Dark Grey (Anthracite for Cooper S/SD).

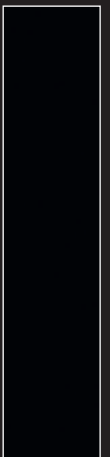

4BD
Piano Black
■ ■ ■

Standard on

- MINI One/D Countryman
- MINI Cooper/D Countryman
- MINI Cooper S/SD Countryman

Optional on

- MINI One/D Countryman
- MINI Cooper/D Countryman
- MINI Cooper S/SD Countryman

COLOUR LINE.

The inside of the elliptical door rings and decorative insert in the MINI Centre Rail are available in Carbon Black, Polar Beige, Dark Tobacco, Pure Red or Surf Blue. The choice of Colour Line colours depends on the colours specified for the interior and upholstery, so as to ensure a harmonious overall effect.

MINI.CO.UK/CONFIGURATOR



4C1
Carbon Black
■



4C4
Dark Tobacco
■

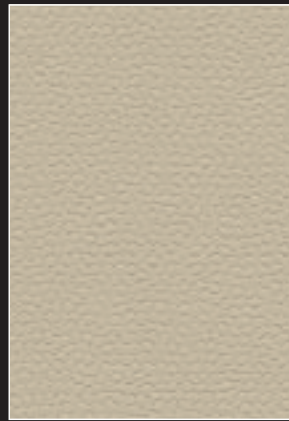

4C2
Polar Beige
■



4C5
Pure Red
■



4C6
Surf Blue
■

STANDARD SEAT CLOTH



SPORT SEAT PARALLEL LINES CLOTH/LEATHER



SPORT SEAT GRAVITY LEATHER





3. COLOURS AND UPHOLSTERY.

UPHOLSTERY.¹



Cosmos cloth²
APE1 Carbon Black



Diagonal Track cloth³
BBE1 Carbon Black



Parallel Lines cloth/leather³
FSGZ Carbon Black/Light Tobacco



Parallel Lines cloth/leather³
FSGY Carbon Black/Pure Red



Dark Tobacco
Carbon Black
Carbon Black



Carbon Black
Dark Tobacco
Carbon Black



Dark Tobacco
Carbon Black
Carbon Black



Carbon Black
Pure Red
Carbon Black



Carbon Black
Carbon Black
Carbon Black



Carbon Black
Carbon Black
Carbon Black



Carbon Black
Polar Beige
Carbon Black



Carbon Black
Carbon Black
Carbon Black

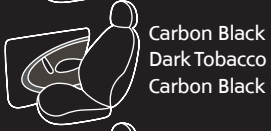

Carbon Black
Dark Tobacco
Carbon Black



Carbon Black
Surf Blue
Carbon Black



Carbon Black
Dark Tobacco
Carbon Black



Carbon Black
Polar Beige
Carbon Black



Carbon Black
Pure Red
Carbon Black



Carbon Black
Surf Blue
Carbon Black

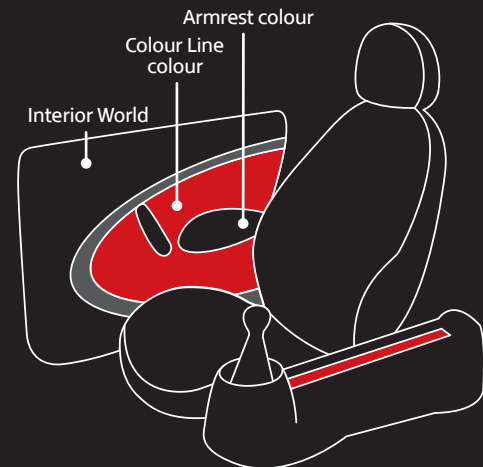

[MINI.CO.UK/CONFIGURATOR](https://www.mini.co.uk/configurator)



Interior World
Colour Line colour
Armrest colour

Standard on

- MINI One/D Countryman
- MINI Cooper/D Countryman
- MINI Cooper S/SD Countryman

Optional on

- MINI One/D Countryman
- MINI Cooper/D Countryman
- MINI Cooper S/SD Countryman



Gravity leather^{3,5}
T6E1 Carbon Black
■



Gravity leather^{3,5}
T6GW Polar Beige
■



Lounge leather^{4,5}
T9E1 Carbon Black
■



Lounge leather^{4,5}
T9GX Light Coffee
■



UPHOLSTERY AND SEATS.

Your seat, your rules: choose from a variety of cloth, leather and cloth/leather combination upholsteries for your MINI Countryman, all with colour-coordinated interiors.

¹ With matching interior colour combinations.

² Only for standard seat.

³ Only for sport seats.

⁴ Only for four seat versions and sport seats with piping.

⁵ Leather upholstery includes seats (base and backrest), and front and rear headrests.



4. EXTERIOR DESIGN AND WHEELS.

IN LINE WITH YOUR PERSONAL STYLE.



1. Bonnet stripes in White



2. Bonnet stripes in Black



1 Bonnet stripes in White are available in conjunction with a White roof.

2 Bonnet stripes in Black are available in conjunction with a Black roof.

3 The roof of the MINI One/D Countryman always comes in **body colour**, while the **exterior mirror caps** are in **Matt Black**. If a roof in body colour is specified on the MINI Cooper/D Countryman or MINI Cooper S/SD Countryman, then the exterior mirror caps are also available in body colour.

4 5 There is also the option of a **roof** and exterior mirror caps in **White** or **Black**.

Standard on MINI One/D Countryman
 MINI Cooper/D Countryman
 MINI Cooper S/SD Countryman

Optional on MINI One/D Countryman
 MINI Cooper/D Countryman
 MINI Cooper S/SD Countryman



3. Roof in body colour



4. Roof in White



5. Roof in Black



6. Exterior mirror caps in Chrome



The exterior mirrors are electrically adjustable and heated. An aspherical glass on the driver's side minimises blind spots.

Exterior mirror caps in **Matt Black** come as standard on all MINI One/One D models.

In conjunction with a White contrast roof, the **exterior mirror caps** are also in **White**.

If the roof is Black, then the **exterior mirror caps** are likewise painted **Black**.

6 **Exterior mirror caps** in **Chrome** are available as an option in conjunction with any roof colour.



4. EXTERIOR DESIGN AND WHEELS.



1. Chrome Line Exterior



2. Chrome Line Exterior



3. Chrome Line Exterior



4. Chrome Line Exterior



5. Chrome Line Exterior



6. Chrome Line Exterior



1 3 5 At the front of the **MINI One/One D Countryman** and **MINI Cooper/Cooper D Countryman**, the **Chrome Line Exterior** comprises chrome-plating of the radiator grille bars and the surround for the lower grille. At the rear, the registration plate surround in the bumper is chrome-plated, and the trims for the side design elements with their built-in orange direction indicator lights are likewise in chrome.

2 4 6 At the front of the **MINI Cooper S/Cooper SD Countryman**, the **Chrome Line Exterior** includes chrome-plating of the brake-cooling air intakes as well as the side design elements for the direction indicator lights in chrome. The rear diffuser has a chrome trim and the roof rails change from Matt Anthracite to Matt Silver.

Standard on

■ MINI One/D Countryman

■ MINI Cooper/D Countryman

■ MINI Cooper S/SD Countryman

Optional on

□ MINI One/D Countryman

□ MINI Cooper/D Countryman

□ MINI Cooper S/SD Countryman



7. Roof rails



8. Darkened rear glass



9. White direction indicator lights



10. Rear-mounted rack preparation



11. Tow bar with removable ball head



7 The **roof rails** are elegant and sleek for optimum aerodynamic efficiency. On the MINI One/D Countryman and MINI Cooper/D Countryman they are Matt Silver in colour, while on the MINI Cooper S/SD Countryman they come in Matt Anthracite.

8 **Darkened rear glass** reduces the build-up of heat in the interior of the car caused by strong sunlight, making things more comfortable for the occupants. Where this option is specified, the glass is visibly darker from the B-pillars backwards (including the rear windscreen).

9 **White indicators** (standard for Cooper S/SD models) comprise of front, side and rear lamp lenses.

10 The standard **rear-mounted rack preparation** is located in the rear bumper.

11 The **tow bar with removable ball head** is suitable for towing loads of up to 1200 kg on certain models.



4. EXTERIOR DESIGN AND WHEELS.



1. Steel wheels incl. small centre hub caps



2. 5-Star Single Spoke, Silver



3. 5-Hole Circular Spoke, Silver



4. 5-Star Double Spoke, Silver



5. 5-Star Double Spoke, Black



6. 5-Star Double Spoke, Matt Anthracite



- 1 Steel wheels incl. small centre hub caps. Size: 6.5 J x 16", tyres: 205/60 R16.
- 2 5-Star Single Spoke light-alloy wheels. Size: 6.5 J x 16", tyres: 205/60 R16.
- 3 5-Hole Circular Spoke light-alloy wheels. Size: 6.5 J x 16", tyres: 205/60 R16.

- 4 5-Star Double Spoke light-alloy wheels in Silver. Size: 7.0 J x 17", tyres: 205/55 R17.
- 5 5-Star Double Spoke light-alloy wheels in Black. Size: 7.0 J x 17", tyres: 205/55 R17.
- 6 5-Star Double Spoke light-alloy wheels in Matt Anthracite. Size: 7.0 J x 17", tyres: 205/55 R17.

[MINI.CO.UK/CONFIGURATOR](https://www.mini.co.uk/configurator)



Standard on

MINI One/D Countryman

MINI Cooper/D Countryman

MINI Cooper S/SD Countryman

Optional on

MINI One/D Countryman

MINI Cooper/D Countryman

MINI Cooper S/SD Countryman



7. Tunnel Spoke, Matt White



8. Tunnel Spoke, Matt Anthracite



9. Turbo Fan, Silver



10. Turbo Fan, Matt White



11. 5-Star Double Spoke Composite, Black



12. Turbo Fan, Matt Anthracite



13. 5-Star Double Spoke Composite, Matt Anthracite

7 Tunnel Spoke light-alloy wheels in Matt White. Size: 7.0 J x 17", tyres: 205/55 R17.

8 Tunnel Spoke light-alloy wheels in Matt Anthracite. Size: 7.0 J x 17", tyres: 205/55 R17.

9 Turbo Fan light-alloy wheels in Silver. Size: 7.5 J x 18" tyres: 225/45 R18 run-flat tyres.

10 Turbo Fan light-alloy wheels in Matt White. Size: 7.5 J x 18", tyres: 225/45 R18 run-flat tyres.

11 5-Star Double Spoke Composite light-alloy wheels in Black. Size: 7.5 J x 18", tyres: 225/45 R18 run-flat tyres.

12 Turbo Fan light-alloy wheels in Matt Anthracite. Size: 7.5 J x 18", tyres: 225/45 R18 run-flat tyres.

13 5-Star Double Spoke Composite light-alloy wheels in Matt Anthracite. Size: 7.5 J x 18", tyres: 225/45 R18 run-flat tyres.



5. INTERIOR DESIGN.



1. 2-spoke standard steering wheel



2. 2-spoke leather steering wheel



3. 3-spoke sport leather steering wheel



4. 3-spoke sport leather steering wheel with multi-function option



SEE IT, WANT IT,
TOUCH IT, LOVE IT.

1 The **2-spoke standard steering wheel** has a driver airbag built in. The horn is sounded by pressing the chrome-edged impact absorber.

2 The **2-spoke leather steering wheel** has a driver airbag built in. The wide chrome ring is an eye-catching design detail.

3 The **3-spoke sport leather steering wheel** is available as an option on all MINI Countryman models (as standard on MINI Cooper S/SD models). It sits comfortably in the hand, for even more agile handling.

4 The **3-spoke sport leather steering wheels** are also available with a **multi-function** option, allowing drivers to operate cruise control, radio and telephone functions without taking their hands off the wheel.

Standard on

- MINI One/D Countryman
- MINI Cooper/D Countryman
- MINI Cooper S/SD Countryman

Optional on

- MINI One/D Countryman
- MINI Cooper/D Countryman
- MINI Cooper S/SD Countryman



5. Chrome Line Interior



6. Chrome Line Interior (gear lever surround)



7. Chrome Line Interior (speedo)



8. Chrome Line Interior (rev counter)



5-8 The ring on the steering wheel, the decorative ring in the air-conditioning control area and the glove compartment and door handles are always finished in chrome. If the optional **Chrome Line Interior** is specified, the rings around the

centre speedo, rev counter, the two air vents at the side of the instrument panel and the ring around the gear lever are also finished in chrome.



5. INTERIOR DESIGN.

ADJUSTS TO SUIT YOUR MOOD.



1. Full-length MINI Centre Rail (4-seater version)



2. 2-part MINI Centre Rail (4-seater version)



3. Short MINI Centre Rail (standard 5-seater version)



1–3 The most striking feature of the interior is the aluminium **MINI Centre Rail**, which runs down the middle of the car between the driver and passenger seats. In conjunction with the optional Storage Compartment Pack, different elements¹ can be mounted on this, sliding along and locking into place where you want them. A fixed decorative insert in the Colour Line colour ensures the MINI Centre Rail coordinates with the interior colour scheme. Three different versions of the MINI Centre Rail are available aligned to the rear seat configuration. Where the optional MINI navigation system or MINI Radio Visual BOOST is fitted, the MINI Centre Rail is also equipped with a joystick to control this.

1 Models with two back seats (4-seater) have the **full-length MINI Centre Rail**, which gives all the car's occupants easy access to the MINI Rail system. It is supplied with three dividing elements.

2 Available as an option, models with two back seats (4-seater) can also specify a **2-part MINI Centre Rail** which is divided into separate sections for the front and rear, and is also supplied with three dividing elements.

3 The standard three-seat (5-seater) rear bench has a **short MINI Centre Rail**, with two dividing elements.

¹ Additional attachments available as Genuine MINI Accessories.

Standard on

■ MINI One/D Countryman

■ MINI Cooper/D Countryman

■ MINI Cooper S/SD Countryman

Optional on

□ MINI One/D Countryman

□ MINI Cooper/D Countryman

□ MINI Cooper S/SD Countryman



4. Two separately adjustable rear seats

□ □ □



5. Three-seat rear bench

■ ■ ■



6. Three-seat rear bench

■ ■ ■



7. Luggage compartment, two rear seats

□ □ □



8. Flat load floor, two rear seats

□ □ □



9. Flat load floor, three-seat rear bench

□ □ □

4 The MINI Countryman comes with optional (no cost) twin, **separately adjustable rear seats**. These can move forward and back and have angle-adjustable backrests, which can be folded down in seconds using the operating handle.

5 6 The seat base sections of the standard **three-seat rear bench** are split 60:40 and can be moved forwards and backwards independently of each other. The backrest has a 40:20:40 split, and again the sections can be tilted and folded down separately. This gives you enormous flexibility to adjust the amount of leg room, luggage capacity and comfort for rear seat passengers.

7 Four-seat models come as standard with a **luggage compartment cover**. In the vertical position, this separates the luggage area from the passenger space, and when folded down into the horizontal position, it provides a flat loading surface. It can also be taken out entirely.

8 A removable **flat load floor** is available as an option on four-seat models to cover the depression in the bottom of the luggage compartment.

9 The **flat load floor** is also available as an option on five-seat models.



5. INTERIOR DESIGN.

LITTLE THINGS THAT MAKE A BIG DIFFERENCE.



1. Horizontal mobile phone holder



2. Full-length MINI Centre Rail with Storage Compartment Pack



3. Full-length MINI Centre Rail with centre armrest in front and rear



1 2 The **Storage Compartment Pack** for vehicles with full-length MINI Centre Rail (four-seater) includes two additional cupholders, a stylish sunglasses compartment and a horizontal mobile phone holder for the front and vertical mobile phone holder for the rear. These elements can be attached to the MINI Centre Rail in a variety of positions, using an adapter which is supplied as part of the pack. The pack also includes two bag hooks, fixing elements for the front cupholders, a storage net in the front passenger footwell and a 12-volt socket in both the back row of seats and the luggage compartment. In the headliner of the driver's side, there is a grab handle. The vertical mobile phone holder, 12-volt socket in the back row of seats, bag hooks and two additional cupholders are not included for vehicles with a shorter MINI Centre Rail.

3 The folding **centre armrests** in the front and rear are height-adjustable between three positions, and incorporate a storage dish. The front armrest is available separately, but the rear armrest is only available in conjunction with the front one.

Standard on ■ MINI One/D Countryman
■ MINI Cooper/D Countryman
■ MINI Cooper S/SD Countryman

Optional on □ MINI One/D Countryman
□ MINI Cooper/D Countryman
□ MINI Cooper S/SD Countryman



4. Anthracite headlining

□ □



5. Smoker's Pack

□ □



6. Interior Lights Pack, ambient light in elliptical door ring

□ □



7. Interior Lights Pack, ambient light in MINI Centre Rail

□ □

4 Anthracite headlining is available for all MINI Countryman models.

5 The Smoker's Pack consists of a cigarette lighter and a removable ashtray.

6 7 In addition to the standard interior light in the headliner, the Interior Lights Pack includes reading and footwell lights in the front, illuminated vanity mirrors, and the instrument panel backlight, plus ambient lighting for the door handle, elliptical door ring and MINI Centre Rail, which is variable through a range of colours.



6. MUSIC, COMMUNICATIONS AND TECHNOLOGY.

FOUR STEPS TO YOUR OWN PERSONAL WORLD OF INFOTAINMENT.



Tailor the information, communication and entertainment functions of your MINI Countryman to your personal preferences in four easy steps. First you have to choose a head unit – the large display of the MINI Radio Visual BOOST in particular opens up a whole new world of interactive possibilities. You can then choose the services, music and Bluetooth/USB options that are right for you, from MINI Connected to the MINI Navigation system. (The brochure shows a selection of these.) Whether you want technology that keeps you connected or navigation that keeps you on the straight and narrow (or even both), you're sure to find a solution that meets your requirements.

Standard on ■ MINI One/D Countryman
■ MINI Cooper/D Countryman
■ MINI Cooper S/SD Countryman

Optional on □ MINI One/D Countryman
□ MINI Cooper/D Countryman
□ MINI Cooper S/SD Countryman

① HEAD UNIT.



1. MINI Radio BOOST CD



2. MINI Radio Visual BOOST



② SERVICES.



3. MINI Navigation system



1 The standard **MINI Radio BOOST CD** has a two-column display, antenna diversity for optimum reception, controls for external audio players and the like, basic Bluetooth telephone preparation with USB audio interface and a DAB radio tuner.

2 The **MINI Radio Visual BOOST** has all the features of the MINI Radio BOOST CD, and then some. A high-resolution 6.5-inch display with comfortable intuitive control system and a distinctive MINI look and feel, a Bluetooth hands-free kit with USB audio interface, an on-board computer and an audio/video adapter for the Apple iPod/iPhone¹. The built-in video function (in conjunction with compatible videocapable Apple devices) allows videos to be watched on the display when the car is stationary. The Radio MINI Visual Boost is "MINI Connected ready", meaning that for a fee it can be upgraded with the MINI Connected option.²

3 The **MINI Navigation system** features a 16:9 monitor built into the centre speedo and an on-board computer. It offers all the functions of the MINI Radio Visual BOOST, but is also a powerful navigation solution, with navigation instructions given via voice prompts, on-screen arrows and/or maps. It also includes day and night modes, a search function for "Points of Interest" and support for updates via the USB interface. Map data is stored in the system's on-board flash memory.

¹ iPod is a trademark of Apple Computer, Inc.

² For information on the compatibility of devices for audio, video and telephone functions, visit: MINI.com/connectivity



6. MUSIC, COMMUNICATIONS AND TECHNOLOGY.

② SERVICES.



1. MINI Connected (list of functions)



2. MINI Connected (Driving Excitement)



3. MINI Connected (Web radio)



1-3 Full speed ahead on the information super-highway: **MINI Connected** revolutionises the world of in-car infotainment, seamlessly linking car and driver with the online world. An all-new USB interface integrates the sophisticated features of your iPhone (not supplied) seamlessly into the audio and infotainment system of your MINI. Information and contents appear on the central display in typical MINI style and are controlled via either the MINI joystick or the three-spoke sports leather steering wheel with multi-function option. "MINI Connected ready" apps like the MINI Connected iPhone app allow you to play back web radio stations, connect to Facebook and Twitter or get the latest news via RSS feeds. Another highlight is the Driving Excitement function, which includes a digital sport display and analyses how sporty and accurate your driving style is. The best thing, however, is that from now

on you'll be able to view and operate iPod functions in the familiar and intuitive Apple menu system in your MINI, all thanks to the revolutionary MINI Connected PlugIn.^{1,2}

¹Additional optional equipment required.

²Availability and range of features are dependent on the other equipment fitted, and may vary from country to country. Range and design of MINI Connected functions subject to change without notice. Broadband mobile internet access required. Costs resulting from this (e.g. data roaming) will be payable as specified in the contract with your network provider. MINI Connected app available free of charge from the device manufacturer's app store (subject to national restrictions). Updates available free of charge, but version upgrades may be chargeable. If further MINI Connected-compatible apps become available, these will be identified/promoted accordingly. For more information about device compatibility and the functions contained in MINI Connected, visit: MINI.com/connectivity

Standard on

■ MINI One/D Countryman

■ MINI Cooper/D Countryman

■ MINI Cooper S/SD Countryman

Optional on

□ MINI One/D Countryman

□ MINI Cooper/D Countryman

□ MINI Cooper S/SD Countryman

3 MUSIC.



4. Harman Kardon hi-fi system



5. Harman Kardon hi-fi system

4 BLUETOOTH/USB.



6. Basic Bluetooth telephone preparation with USB audio interface



7. Full Bluetooth telephone preparation with USB audio interface

4 5 Harman Kardon hi-fi system: a 640-watt digital multi-channel amplifier, and a total of ten high-performance speakers seamlessly integrated into the vehicle interior deliver a unique sound experience, with powerful low-range tones thanks to the central bass design, and brilliant treble.

6 The standard basic **Bluetooth telephone preparation with USB audio interface** connects wirelessly to Bluetooth-enabled mobile phones. The USB audio interface supports the connection of an iPod³, USB memory stick or MP3 player. Users can select tracks stored on the device by album, artist, genre etc. via the radio or optional central display.⁴

7 The **Full Bluetooth telephone preparation with USB audio interface** option also includes a centre armrest and a three-spoke sports leather steering wheel with multi-function option and cruise control. With a snap-in adapter, available for a fee, a Bluetooth-enabled mobile phone can be plugged in to a slot in the armrest, which charges its battery, and connects it to the vehicle aerial for improved reception. In conjunction with the optional MINI Radio Visual BOOST you can use many of the functions on your smartphone, such as the calendar, Bluetooth audio streaming and album cover artwork display, easily and safely on the radio display.^{4,5}

⁴ For information on the compatibility of devices for audio, video and telephone functions, visit: MINI.com/connectivity

⁵ Subject to availability of device-specific snap-in adapters.

³ iPod is a trademark of Apple Computer, Inc.



6. MUSIC, COMMUNICATIONS AND TECHNOLOGY.

YOUR MINI TELLS YOU EVERYTHING EXCEPT YOUR HEART RATE.



1. Speedo with MINI Radio BOOST CD



2. Speedo with MINI Radio Visual BOOST



3. Rev counter



4. On-board computer



5. Rain sensor



1 2 The large **speedo** is positioned in the middle of the instrument panel, and incorporates various warning lights and the fuel gauge. If the MINI Navigation system or MINI Radio Visual BOOST is fitted, the speedo runs round the outside.

3 The **rev counter** is mounted on the middle of the steering column. The upper display shows the current speed, while the lower display shows such information as the trip distance or seat belt warning for the rear seats. It also includes the Shift Point Display, telling you which gear is the most economical at any given moment.

4 The optional **on-board computer** tells you your range, current and average fuel consumption, and average speed at the touch of a button.

The **Condition Based Service (CBS)** system comes as standard, and warns you when the next oil change or service is due, with a digital countdown of the distance to the next service appearing in the lower display of the rev counter.

5 When the **rain sensor** is activated, it automatically switches on the windscreen wipers when necessary, and adjusts their speed to how hard it is raining. The built-in light sensor automatically switches on the driving lights when needed in dark or twilight conditions.

Standard on

■ MINI One/D Countryman

■ MINI Cooper/D Countryman

■ MINI Cooper S/SD Countryman

Optional on

□ MINI One/D Countryman

□ MINI Cooper/D Countryman

□ MINI Cooper S/SD Countryman



6. Air conditioning

■ ■ ■



7. Automatic air conditioning

□ □ □



8. Heated front windscreen

□ □ □



9. Seat heating

□ □ □



10. Central switch cluster

■ ■ ■



11. Start/Stop button

■ ■ ■

6 The **air conditioning** system with microfilter means passengers can enjoy their ideal interior temperature, whatever the conditions outside. The amount and distribution of conditioned air can be individually adjusted.

7 **Automatic air conditioning** rapidly adjusts the interior temperature to the desired level, and then keeps it constant. An integrated active carbon filter protects passengers against unpleasant odours from outside.

8 The **heated front windscreen** ensures drivers can always see clearly. It includes a heated front windscreen, rain sensor, automatic lights-on, auto-dimming interior rear view mirror and front fog lights.

9 The **seat heating** option allows both the driver and front-seat passenger to choose between three seat temperature settings.

10 The **central switch cluster** at the bottom of the centre console brings the controls for a variety of important functions together in one place, including Tyre Pressure Control, front and rear fog lights, child locking for rear windows, the Sport button and Dynamic Stability Control (DSC). Exact layout depends on optional equipment specified.

11 Once the key is in the ignition, the **Start/Stop button** can be used to switch the engine on or off.



6. MUSIC, COMMUNICATIONS AND TECHNOLOGY.



1. Bi-xenon headlights



2. Adaptive headlights



3. Rear fog light



4. Fog lights



1 The optional **bi-xenon headlights** for dipped and full-beam settings, with headlight beam-throw control and headlight washer system, offer particularly powerful illumination.

2 The **Adaptive headlights** provide optimum illumination of the road when cornering, and allow drivers to see further ahead when travelling at speed. Sensors measure the steering angle, rate of turn and vehicle speed, and electric motors, then adjust the position of the light beam accordingly. (Only available in conjunction with bi-xenon headlights.)

3 The **rear fog light** is built into the rear light unit on the driver's side, while the rear light unit on the passenger side houses the reversing light.

4 The **fog lights** are built into the front bumper, and offer improved safety when visibility is poor.

Standard on

■ MINI One/D Countryman

■ MINI Cooper/D Countryman

■ MINI Cooper S/SD Countryman

Optional on

□ MINI One/D Countryman

□ MINI Cooper/D Countryman

□ MINI Cooper S/SD Countryman



5. Park Distance Control (PDC)

■ ■ ■



6. Folding exterior mirrors

□ □ □



7. Rear view mirror with compass function

□ □ □



8. Panoramic glass sunroof - electric

□ □ □



9. Comfort access system

□ □ □



5 **Park Distance Control (PDC)** at the rear makes it easier to park and manoeuvre in tight spaces. An acoustic signal (and a visual display, if the MINI Navigation system or MINI Radio Visual BOOST is also fitted) informs the driver of the distance between the car and any obstacle.

6 With the option of **folding exterior mirrors** it's possible to fold the mirrors away electrically and safely.

The **Auto-dimming exterior mirrors and interior rear view mirror** dim the light from the headlights of following vehicles if this reaches a certain level of intensity.

7 With the **rear view mirror with compass function**, a digital display is built into the mirror, showing which direction the car is heading in.

8 The large opening of the **panoramic glass sunroof** lets in plenty of fresh air. Electronic controls operate the front/rear vent function, and there is also a remote-control convenient opening function. Tinted glass and two detachable roller sunblinds built into the central section of the roof protect the occupants from bright sunlight.

9 The **comfort access system** allows you to lock and unlock the car without even having to touch the key. Simply having one of the two keys in your pocket or handbag is enough. You can also switch the ignition on and off keylessly, simply by pressing the Start/Stop button.



7. PERFORMANCE.



1. Sport suspension



2. Sport suspension



3. ALL4¹



4. Rear spoiler



5. Rear spoiler



1 2 The sport suspension set-up delivers even more precise and sporty handling responses, thanks to its stiffer damper settings. 10 millimetres lower than the standard suspension, it looks good too.

3 The MINI Cooper D **ALL4** Countryman and Cooper S/SD **ALL4** Countryman feature all-wheel drive providing you with that extra level of security and enabling you to head off the beaten track.

4 The **rear spoiler** is always painted in the same colour as the roof, and fits seamlessly into its lines.

5 The **MINI Cooper S/SD Countryman rear spoiler** is the same colour as the roof, and reflects the racing heritage of the MINI.

¹ Available for MINI Cooper D Countryman, MINI Cooper S Countryman and MINI Cooper SD Countryman.

As standard on

- MINI One/D Countryman
- MINI Cooper/D Countryman
- MINI Cooper S/SD Countryman

Optional on

- MINI One/D Countryman
- MINI Cooper/D Countryman
- MINI Cooper S/SD Countryman



6. 6-speed automatic gearbox

²



7. Shift paddles on 3-spoke sport leather steering wheel



8. 6-speed manual gearbox



9. Sport button

6 7 The **6-speed automatic gearbox** makes gear changes easier, and – in Steptronic mode – decidedly sporty. On the MINI Cooper S/SD Countryman, there are two shift paddles on the 3-spoke sport leather steering wheel in addition to the selector lever (shift paddles are available as an option on the MINI One Countryman, MINI Cooper Countryman and MINI Cooper D Countryman). These allow drivers to make manually initiated automatic gear changes quickly and safely without taking their hands off the wheel.

8 The **6-speed manual gearbox** has a pleasingly light feel and a short throw, for quick, precise changes.

9 Pressing the **sport button** further improves the car's responses to throttle and steering inputs, for an even more involving drive. On vehicles with an automatic gearbox, it makes gearshift times faster too.

² Not available for MINI One D Countryman.



8. ACCESSORIES.



MINI Cooper Countryman with Genuine MINI Accessories



Rail-Box with Care Tissues Box



All-weather floor mats



Rear-mounted bike rack

With **Genuine MINI Accessories**¹, you can give your MINI Countryman a look that is all your own. For the exterior, there are a wealth of stylish components such as the striking optical under-ride kit, cool designs for the exterior mirror caps and rear-view mirror housing, and various side scuttles and sports stripes are a visual expression of the car's energetic personality. For the interior, there are practical solutions such as child seats that offer optimum safety for smaller passengers, the rail note holder for

the MINI Centre Rail, various different floor mats and a holder for a portable navigation device. And for longer trips or leisure pursuits, there is an array of smart luggage compartment solutions and transportation accessories, including a surfboard holder, roof box and aluminium rear-mounted rack. Whatever you want to do in your MINI Countryman, with Genuine MINI Accessories the fun is guaranteed.

JOHN COOPER WORKS TUNING.



MINI Cooper S Countryman with John Cooper Works Tuning



Double Spoke R129 in Burnished Black



Sports steering wheel in Alcantara



Sports silencer in Chrome



John Cooper Works Tuning¹ delivers a true racetrack experience. The striking aerodynamic package comprises front and rear apron attachments and side skirts. The side skirts are painted in body colour, and incorporate racing-style air intakes, while a diffuser in the rear apron ensures improved downforce. The effect is completed by the large tailpipe finishers. Exterior mirror caps in

Chili Red or Carbon and sport stripes further enhance the racy look, and the 19-inch Double Spoke R129 light-alloy wheels with runflat tyres combine eye-catching styling with racing character. In the interior too, John Cooper Works components create a genuine race-car ambience, with options such as the additional instruments and a sport steering wheel in Alcantara or leather.

¹ For more information, visit MINI.co.uk/accessories.

TECHNICAL DATA.

ENGINE ^{1,2}		MINI ONE COUNTRYMAN	MINI ONE D COUNTRYMAN	MINI COOPER COUNTRYMAN
Cylinders/layout/valves per cylinder		4/in-line/4	4/in-line/4	4/in-line/4
Displacement	cm ³	1598	1598	1598
Stroke/bore	mm	85.8/77.0	83.6/78.0	85.8/77.0
Max. output/max. revs	hp(kW)/rpm	98(72)/6000	90(66)/4000	122(90)/6000
Max. torque/revs	Nm/rpm	153/3000	215/1750–2500	160/4250
Compression ratio/recommended fuel	:1	11.0/91–98 ROZ	16.5/Diesel	11.0/91–98 ROZ
PERFORMANCE¹				
Max. speed	mph km/h	107 [104] 173 [168]	106 170	118 [113] 190 [182]
Acceleration 0–62 mph (0–100 km/h)	sec	11.9 [13.9]	12.9	10.5 [11.6]
Acceleration 50–75 mph (80–120 km/h) (4th/5th gear)	sec	13.9/17.9	12.5/15.9	11.6/14.9
FUEL CONSUMPTION^{1,2}				
Urban	mpg l/100 km	38.2 [30.4] 7.4 [9.3]	60.1 4.7	38.2 [30.4] 7.4 [9.3]
Extra-urban	mpg l/100 km	54.3 [47.1] 5.2 [6.0]	67.3 4.2	54.3 [47.1] 5.2 [6.0]
Combined	mpg l/100 km	47.1 [39.2] 6.0 [7.2]	64.2 4.4	47.1 [39.2] 6.0 [7.2]
CO ₂ emissions	g/km	139 [168]	115	140 [168]
Tank capacity, approx.	l	47	47	47
Range	miles/km	488/785 [407/655]	665/1070	488/785 [407/655]
WEIGHT¹/LUGGAGE CAPACITY				
Unladen weight (EU) ⁴	kg	1340 [1370]	1385	1340 [1370]
Max. permitted weight	kg	1775 [1805]	1820	1775 [1805]
Max. permitted load	kg	510	510	510
Max. permitted axle load, front/rear	kg	935/855 [965/855]	995/850	930/855 [960/855]
Max. permitted towing weight (braked/unbraked)	kg	–	–	[1000/500]
Luggage capacity	l	350/450–1170	350/450–1170	350/450–1170
WHEELS				
Tyre dimensions, front/rear		205/60 R 16 92H	205/60 R 16 92H	205/60 R 16 92H
Wheel dimensions, front/rear		6.5 J x 16" steel	6.5 J x 16" steel	6.5 J x 16" light alloy

¹ All figures relate to vehicles with the standard 6-speed manual gearbox. Figures in square brackets relate to vehicles with 6-speed Automatic gearbox Steptronic.

² All MINI Countryman models comply with the EU5 exhaust emissions standard. Fuel consumption is determined in accordance with the ECE driving cycle (as defined in Directive 80/1268/EEC), made up of approximately one third urban and two thirds extra-urban driving (based on the distance covered). CO₂ emissions are measured separately from fuel consumption. Figures relate to standard-specification vehicles, and may vary significantly where optional equipment (including wider tyres) is fitted.

MINI COOPER D COUNTRYMAN	MINI COOPER D ALL4 COUNTRYMAN	MINI COOPER S COUNTRYMAN	MINI COOPER S ALL4 COUNTRYMAN	MINI COOPER SD COUNTRYMAN	MINI COOPER SD ALL4 COUNTRYMAN
4/in-line/4	4/in-line/4	4/in-line/4	4/in-line/4	4/in-line/4	4/in-line/4
1598 [1995]	1598 [1995]	1598	1598	1995	1995
83.6/78.0 [90.0/84.0]	83.6/78.0 [90.0/84.0]	85.8/77.0	85.8/77.0	90.0/84.0	90.0/84.0
112(82)/4000	112(82)/4000	184(135)/5500	184(135)/5500	143(105)/4000	143(105)/4000
270/1750–2250	270/1750–2250	240/1600 – 5000 (260/1700–4500) ³	240/1600 – 5000 (260/1700–4500) ³	305/1750–2700	305/1750–2700
16.5/Diesel	16.5/Diesel	10.5/91–98 ROZ	10.5/91–98 ROZ	16.5/Diesel	16.5/Diesel
115 [112] 185 [180]	112 [109] 180 [175]	134 [130] 215 [210]	130 [127] 210 [205]	123 [121] 198 [195]	121 [120] 195 [193]
10.9 [11.3]	11.6 [11.8]	7.6 [7.9]	7.9 [8.3]	9.3 [9.5]	9.4 [9.5]
9.7/11.9	10.6/12.9	7.1/8.6	7.2/9.4	7.9/10.1	8.5 [10.7]
60.1 [39.2] 4.7 [7.2]	53.3 [37.2] 5.3 [7.6]	37.7 [29.7] 7.5 [9.5]	34.4 [27.4] 8.2 [10.3]	54.3 [38.7] 5.2 [7.3]	53.3 [36.7] 5.3 [7.7]
67.3 [60.1] 4.2 [4.7]	60.1 [56.5] 4.7 [5.0]	52.3 [49.6] 5.4 [5.7]	48.7 [45.6] 5.8 [6.2]	65.7 [58.9] 4.3 [4.8]	60.1 [55.4] 4.7 [5.1]
64.2 [50.4] 4.4 [5.6]	57.6 [47.1] 4.9 [6.0]	46.3 [39.8] 6.1 [7.1]	42.2 [36.7] 6.7 [7.7]	61.4 [49.6] 4.6 [5.7]	57.6 [46.3] 4.9 [6.1]
115 [149]	129 [158]	143 [166]	157 [180]	122 [150]	130 [160]
47	47	47	47	47	47
665/1070 [522/840]	597/960 [488/785]	478/770 [410/660]	435/700 [379/610]	634/1020 [513/825]	597/960 [478/770]
1385 [1410]	1455 [1480]	1385 [1410]	1455 [1480]	1395 [1420]	1470 [1495]
1820 [1845]	1890 [1915]	1820 [1845]	1890 [1915]	1830 [1855]	1905 [1919]
510	510	510	510	510	510
985/850 [1005/850]	1010/890 [1030/890]	960/855 [980/855]	980/895 [1000/895]	995/855 [1015/855]	1015/900 [1035/900]
800/500 [1200/500]	800/500 [1200/500]	750/500 [1000/500]	750/500 [1000/500]	800/500 [1200/500]	800/500 [1200/500]
350/450–1170	350/450–1170	350/450–1170	350/450–1170	350/450–1170	350/450–1170
205/60 R 16 92H	205/60 R 16 92H	205/55 R 17 91V	205/55 R 17 91V	205/55 R 17 91V	205/55 R 17 91V
6.5 J x 16" light alloy	6.5 J x 16" light alloy	7.0 J x 17" light alloy	7.0 J x 17" light alloy	7.0 J x 17" light alloy	7.0 J x 17" light alloy

³ With overboost function.

⁴ The figure quoted includes a 90% tank filling, 68 kg for the driver and 7 kg for luggage. Unladen weight applies to vehicles with standard equipment. Optional equipment may increase this figure.

DIMENSIONAL DRAWINGS.

MINI ONE COUNTRYMAN. MINI ONE D COUNTRYMAN. MINI COOPER COUNTRYMAN.
MINI COOPER D COUNTRYMAN. MINI COOPER D ALL4 COUNTRYMAN.

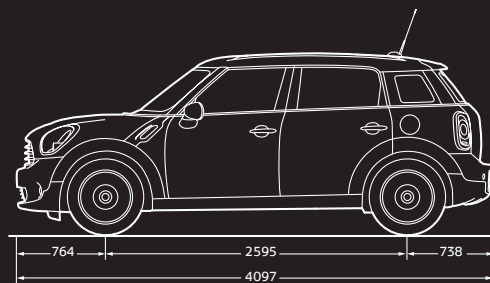
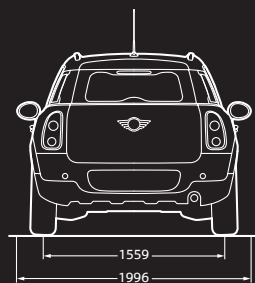
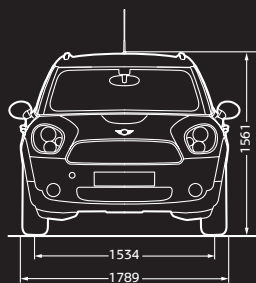

MINI COOPER S COUNTRYMAN. MINI COOPER SD COUNTRYMAN. MINI COOPER S ALL4 COUNTRYMAN.

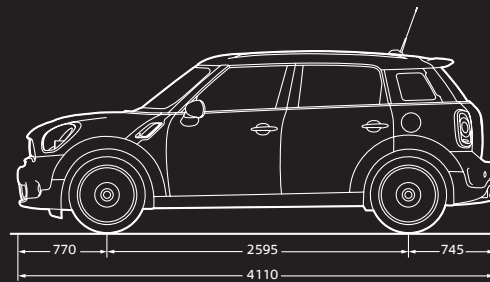
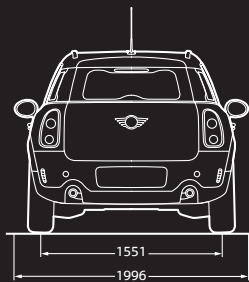
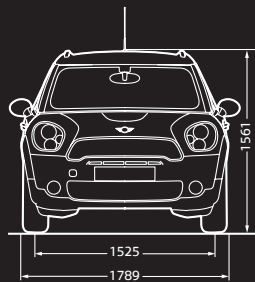

All figures in millimetres.



The models, standard and optional equipment and combinability of options in this brochure relate to cars supplied by BMW AG for the German market. The availability of standard and optional equipment, and the combinability of options, may vary from country to country within the European Union for all models. For detailed information about the situation in your country, please contact your MINI Dealer. Subject to change in design and equipment.

© BMW AG, Munich, Germany. Not to be reproduced, wholly or in part, without written permission of BMW AG, Munich.

UK Part Number: 92.00.0.001.110 March 2012

For more information, visit www.mini.co.uk or www.mini.ie



www.facebook.com/MINI.uk



MINI is affiliated to BMW, an official partner of the London 2012 Games.