

S-Class



Mercedes-Benz



## The definition of a luxury saloon



Since the beginning of the 20th century, our cars have captivated successive generations of drivers with their elegant style and exceptional quality. The S-Class in particular has helped to shape the face of luxury motoring. Its direct line dates back to 1951 and the inaugural Frankfurt Motor Show, where Mercedes-Benz presented its new 6-cylinder 220 saloon, a car whose effortless performance and impressive levels of equipment set the tone for a whole series of great luxury saloons.

The first of these to be officially designated 'S-Class', the W116 range, was launched in 1972. Since then, the name has stood for exceptional comfort, innovative technology and, of course, ground-breaking safety systems. Crumple zones, ABS, ESP® and the airbag, for instance, all made their debut in an S-Class – and went on to become the norm for cars of all makes and sizes. And although that alone means its place in the history books is assured, the S-Class continues to lead the way – with new technology and ever higher standards of luxury.





# First impressions

For generations, the S-Class has set the standard for modern motoring – with innovations in the fields of comfort, safety and environment-friendly technology that have made it a benchmark for automotive progress. The latest S-Class continues that tradition, achieving lower levels of emissions across the engine range, setting new

standards for occupant protection, in-car entertainment and driver assistance, and, of course, wrapping it all in an elegantly contemporary exterior. Rediscover a motoring icon – with the current S-Class.

[Overview](#) | [page 5](#)

## Featured models:

---

**S 500 BlueEFFICIENCY L | Dolomite Brown metallic** | [front cover and page 5](#)

Alloy wheels in multi-spoke design, Exclusive Passion Leather Package in Sahara Beige/Black, trim in Light Burr Walnut wood with gloss finish

---

**S 600 L | Obsidian Black metallic** | [page 10](#)

Alloy wheels in 5-spoke design, Exclusive Passion Leather Package in Cashmere Beige/Savanna Beige, trim in Brown Poplar wood with gloss finish

Specifications shown may include optional equipment and accessories





# Facts

**Refined pleasures:** engines, transmissions and adaptive suspension systems.

Engines and suspension | from page 15

**Integrated safety in the S-Class:** safer driving, anticipating danger, protecting occupants and post-crash safety.

Safety | from page 23

**Stress-relieving comfort:** intelligent assistants, multimedia and high-end audio systems, automatic climate control and ergonomic seats.

Comfort | from page 27

**An S-Class for every need:** long-wheelbase version, S 600 L and S-Guard.

Model variants | from page 33

**Powerful AMG models:** the S 63 AMG L and S 65 AMG L.

AMG | from page 37

**Your S-Class:** standard equipment and optional extras, packages, *designo*, upholstery and trim, wheels and Retailer-fit accessories.

Equipment | from page 41

**More Mercedes-Benz:** test drive, Mercedes-Benz Finance and Insurance, Factory Collection, Interactive Owner's Manual, Roadside Assistance and Mercedes-Benz World.

Services | from page 57

**The S-Class in figures:** model data and dimensions.

Technical data | from page 59





### Efficiency | More enjoyment from less

Often the most impressive accomplishments are those where much is achieved with comparatively little. In driving, that means delivering the maximum amount of pleasure, while minimising the energy required.

As a standard-bearer for automotive progress, the S-Class is, of course, leading the way – with enhanced efficiency across the engine range. → page 17



### Composure | Every journey made effortless

Each new road poses a different set of challenges. Where one is fast, open and endlessly straight; the next may twist, wind and climb. The key is being able to take every situation equally in your stride – with a car that helps you to stay calm and in control, whatever the journey may bring.



### Relaxation | Calm meets concentration

Even breathing, a steady pulse and a clear head are the unmistakable signs of a relaxed driver. And the best way to ensure a relaxed driver is to reduce the potential for danger. In the S-Class, almost a hundred sensors and a range of intelligent on-board assistants do exactly that. → page 23



### Protection | A safe haven on any highway

A jaunt once meant a difficult or wearisome journey – but then road trips once involved bone-hard wheels, insufferable surfaces and often obstinate horses. A drive in today's S-Class is, of course, an infinitely smoother and safer affair. This iconic luxury saloon not only sets the standard for ride comfort, it also helps to keep you from harm, thanks to vigilant assistants that watch out for and alert you to danger. → pages 23 and 39





### Comfort | Seats that seem made for you

The human form is built for walking – and yet nowadays most of us spend as much if not more time sitting. Which is why ergonomic and highly adjustable seats are so important. But as people come in all shapes and sizes, wouldn't it be even better if the seat could change shape to suit its occupant? Try an S-Class with dynamic multi-contour seats and judge for yourself. → page 31



### Emotion | The essential ingredient

“I feel, therefore I am...”. In times when even cars can think, it's the emotional experiences that count – the pleasure derived from an elegant shape, for instance, or the pride that comes from possessing it. For all its intelligence, the S-Class never fails to capture the heart.



**Refinement | Power at its most cultured**

To move a large mass, you need to exert a great deal of effort. Or so you might think. Then you discover how smoothly the S-Class performs, how efficiently it uses its power, and realise that sometimes a lighter touch can achieve just as much. → pages 17-18





**Tranquility | Just the whisper of tyre on tarmac**

What do we hear when all is quiet? Our own heartbeat, perhaps? The blood coursing through our veins? The S-Class is the perfect place to find out.



**15 BlueEFFICIENCY****16 Efficiency in the S-Class****17 Diesel engine**

V6 diesel engine

**18 Petrol engines**

V6 petrol engine

V8 petrol engine

V12 petrol engine

**19 Transmissions**

7G-Tronic Plus

5-speed automatic transmission

**21 Suspension**

AirMATIC air suspension

Active Body Control (ABC)

**23 Integrated safety concept**

Attention Assist

Adaptive High Beam Assist

Night View Assist Plus

Driving Assistance Package

Pre-Safe® Brake and BAS Plus

Pre-Safe® system

Neck-Pro active head restraints

Restraint systems

Post-crash safety

**27 Multimedia systems**

COMAND multimedia system and

Media Interface

Harman Kardon® Front Seat

Entertainment Package with SplitView

**28 Bang & Olufsen BeoSound AMG surround sound system****29 Electronic assistants**

Reversing camera

Advanced Parking Guidance

**31 Seats**

Front Seat Comfort Package

Rear Seat Comfort Package

Rear Seat Memory Package

**32 Luxury automatic climate control****33 Long-wheelbase version****34 S 600 L****35 S-Guard**

**37 AMG**

S 63 AMG L

AMG 5.5-litre V8 engine

AMG Speedshift MCT 7-speed

sports transmission

S 65 AMG L

**41 Standard equipment****42 Optional extras****43 AMG Sports Package****45 *designo****designo* range*designo* Selection**47 Upholstery and trim****53 Alloy wheels****55 Retailer-fit accessories****57 Services**

Test drive

Mercedes-Benz Finance and Insurance

Factory Collection

Interactive Owner's Manual

Roadside Assistance

Mercedes-Benz World

**59 Dimensions****60 Technical data****62 Paint finishes**

## BlueEFFICIENCY – technology for more efficient driving

Our comprehensive BlueEFFICIENCY measures have already brought significant cuts in fuel consumption to many current Mercedes-Benz models, helping to lower both their CO<sub>2</sub> emissions and their running costs. What's more, we are continuing to develop new environmentally friendly technologies that will reduce emissions even further and help to make motoring more sustainable in the long term.

### **BlueEFFICIENCY – the Mercedes-Benz efficiency drive.**

BlueEFFICIENCY models feature a range of measures that can considerably reduce fuel consumption and CO<sub>2</sub> emissions. They include aerodynamic optimisation, low-resistance tyres and intelligent energy management technologies such as the ECO start/stop function, which comes as standard on the majority of our passenger car models. Many of our model ranges also now offer new BlueDIRECT engines. Their innovative direct petrol injection system delivers significantly more power, yet also helps to cut fuel consumption by up to 25%.

**BlueTEC – cleaner diesel power.** BlueTEC is our cleanest diesel technology to date. Its combination of advanced common-rail direct injection, optimised combustion and modular emissions control systems reduces particulate levels by up to 95% and removes up to 90% of nitrogen oxides, leaving little but water and nitrogen.

### **HYBRID – internal combustion at its most intelligent.**

Our hybrid system combines a conventional petrol engine with an electric motor that boosts acceleration and enables brake energy to be recuperated and stored in the battery. In addition, our latest-generation hybrid models offer all-electric propulsion at up to approx. 20 mph, as well as the ability to 'glide' at speeds of up to 100 mph, by shutting down the combustion engine for maximum efficiency and zero emissions. In the E-Class, this advanced hybrid technology can also be enjoyed in diesel form, thanks to the new E 300 BlueTEC HYBRID.<sup>1</sup>

**E-Cell and F-Cell – new drivetrain concepts.** We've also already rolled out limited production runs of two all-electric vehicles with zero local emissions: the A-Class E-Cell<sup>2</sup> and the B-Class F-Cell.<sup>2</sup> The F-Cell uses a hydrogen fuel cell to drive its electric motor, while the E-Cell is powered solely by twin lithium-ion batteries. Our F 125! F-CELL Plug-In HYBRID, meanwhile, demonstrates the possibilities of innovative zero-emission motoring for luxury vehicles.

**Design for Environment.** Our environmental philosophy is not just about in-car technologies. It also involves taking the entire lifecycle of each vehicle into account, from its initial planning to its end-of-life recycling. In addition, Mercedes-Benz is involved in the development of alternative fuels and conducts research in the field of bionics.

For more information about our holistic approach, see [www.mercedes-benz.co.uk/blueefficiency](http://www.mercedes-benz.co.uk/blueefficiency)

<sup>1</sup>E 300 BlueTEC HYBRID Saloon: Euro 5 emissions rating. Fuel consumption, urban: 65.7–67.3 mpg; extra-urban: 65.7–67.3 mpg; combined: 65.7–67.3 mpg; combined CO<sub>2</sub> emissions: 112–109 g/km; efficiency rating A+ <sup>2</sup>Provisional efficiency rating A+  
Figures obtained in accordance with the prescribed measuring process (Regulation 715/2007/EC in the currently applicable version). The figures are not based on an individual vehicle and do not constitute part of the product offer; they are provided solely for purposes of comparison between different vehicle models



## Efficiency in the S-Class

The S-Class has always been at the forefront of technological development. Its latest innovations include fuel-saving BlueEFFICIENCY measures and standard-setting BlueTEC clean diesel technology.



The S-Class features a variety of environment-friendly technologies that help to achieve significant reductions in fuel consumption and emissions. These efficiency-enhancing measures don't just extend to the engines either. Aerodynamic improvements, low-resistance tyres and intelligent energy management all further reduce fuel consumption and CO<sub>2</sub> emissions. In addition, the range includes one of the world's cleanest diesels: the S 350 BlueTEC with exhaust gas aftertreatment.

- 1 Tyres designed for lower rolling resistance
- 2 EU5 compliance for all petrol engines
- 3 Aerodynamic exterior mirror casings
- 4 Fuel-saving steering pump
- 5 Car always starts with transmission in 'E' (economy mode)
- 6 Sealed joints around headlamps for improved aerodynamics
- 7 One of the world's cleanest diesel engines (S 350 BlueTEC meets EU6 emissions standards)

Actual specification varies according to model





# Diesel engine

The fuel-efficient S-Class diesel engine is powerful, refined and cleaner than ever.

**V6 diesel engine with BlueTEC technology.** The S 350 BlueTEC combines outstanding fuel efficiency with exceptionally low exhaust emissions. Its environmentally friendly technology includes a system of exhaust gas aftertreatment that ensures it already meets tomorrow's EU6 emissions standards today, making it one of the

cleanest diesels in the world. In addition, the S 350 BlueTEC offers effortless performance, thanks to an output of 258 hp (190 kW) and 620 Nm of torque. The V6 BlueTEC diesel engine comes with a fuel-saving ECO start/stop function that cuts the engine when stationary.

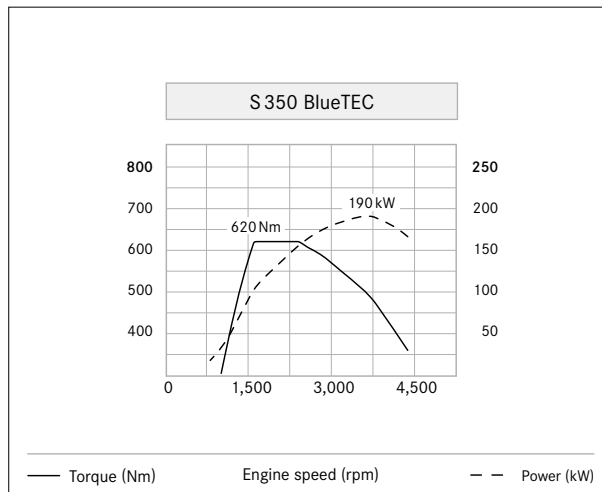

620 Nm of torque is available from 1,600 to 2,400 rpm



The S 350 BlueTEC boasts one of the world's cleanest diesel engines



## Petrol engines

Powerful and yet easy on the environment, the S-Class petrol engines combine impressive outputs with even lower fuel consumption and CO<sub>2</sub> emissions. The innovative V6 and V8 engines with direct petrol injection set new standards for efficient performance, while the S 600 L's optimised V12 meets strict EU5 regulations on exhaust emissions.

**V6 petrol engine.** The V6 for the S 350 BlueEFFICIENCY features spray-guided direct petrol injection via piezo injectors, four valves per cylinder and variable camshaft control. As a result, it delivers increased refinement, greater fuel efficiency and lower CO<sub>2</sub> emissions, despite boasting an impressive 306 hp (225 kW), plus 370 Nm of torque at 3,500 rpm.

**V8 petrol engine.** The S-Class V8 not only uses 19% less fuel than its predecessor, it also offers significantly improved power and torque, thanks to the addition of intercooled twin turbochargers. With an output of 435 hp (320 kW) plus a maximum of 700 Nm at just 1,800 rpm, it gives the S 500 BlueEFFICIENCY L exceptionally rapid acceleration and effortlessly responsive performance at any speed. In addition, both the V6 and V8 models come with a fuel-saving ECO start/stop function that cuts the engine when standing at traffic lights.

**V12 petrol engine.** With its intercooled twin turbochargers and 60-degree V12 layout, the S 600 L's innovative engine offers superlative performance, exceptional refinement and a sublime sound. It has a maximum output of 517 hp (380 kW), delivers a

spectacular 830 Nm of torque from 1,800 rpm and accelerates from 0 to 62 mph in just 4.6 seconds.



State-of-the-art technology: the petrol V8 features high-pressure direct injection via piezo injectors

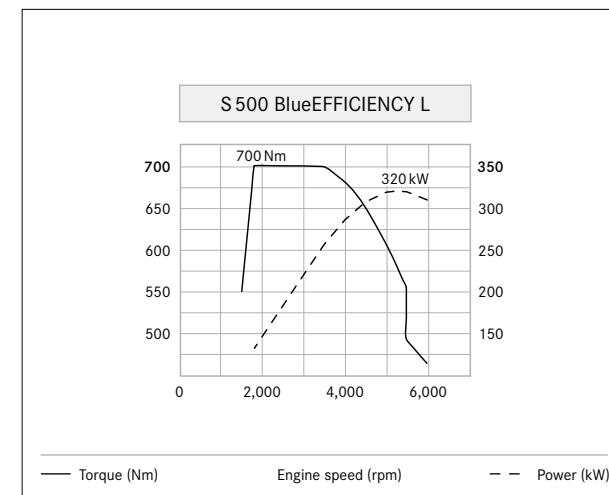

High torque even at low revs

# Transmissions

The S-Class transmissions are perfectly matched to its engines – and let you choose the right mode for your mood.



The Direct Select gear shift lever on the steering column

**7G-Tronic Plus.** The V6- and V8-engined S-Class models come with 7G-Tronic Plus automatic transmission, a version of our 7G-Tronic system that delivers even greater fuel efficiency. Its seven forward gears ensure the engine is always operating at the optimum speed, helping to reduce fuel consumption, while the short, slick shifts make for smoother, quieter driving. The transmission is controlled via the Direct Select gear shift lever on the steering column, while a separate set-up switch enables you to choose between manual, economy and sport modes. In manual mode, you can also change gear using racing-style steering wheel shift paddles.

**5-speed automatic transmission.** The perfect partner for the S 600 L's V12, the 5-speed automatic transmission offers rapid and barely perceptible gear shifts and ensures optimum acceleration in any situation. It also gives you the option of changing gear manually.



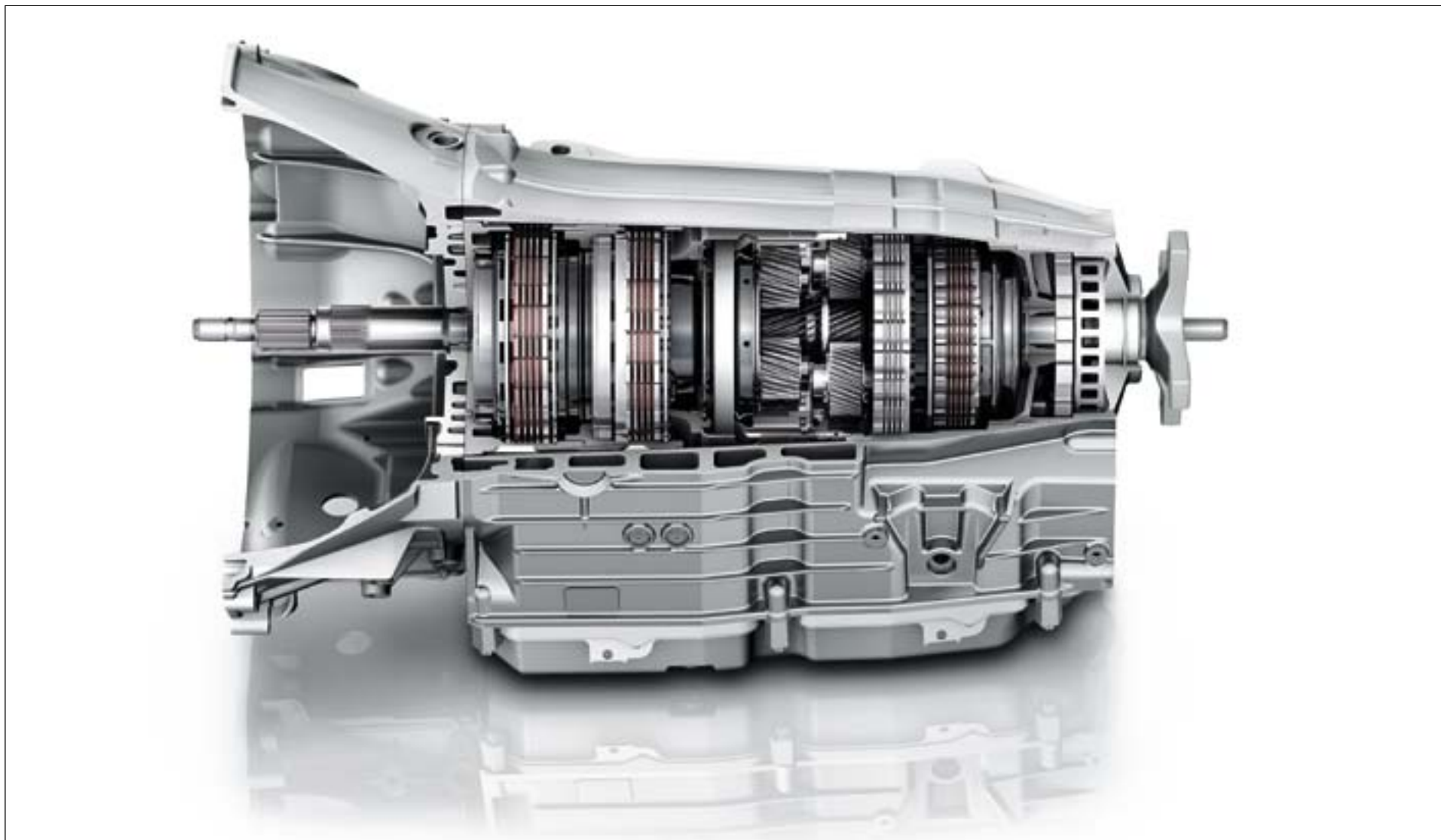

7G-Tronic Plus: the result of more than 50 years' experience in automatic transmission technology



# Suspension

Thanks to intelligent suspension technology, the S-Class guarantees supreme comfort on every surface.

The standard AirMATIC air suspension system optimises ride comfort and agility by constantly adapting to your driving, giving you firmer damping when pressing on and softer settings during more relaxed driving.

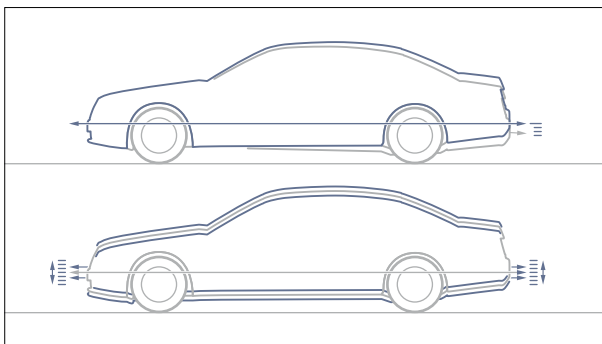

AirMATIC air suspension improves ride comfort, especially on poor road surfaces

For an even more composed ride, there's Active Body Control (ABC).<sup>1</sup> It uses microprocessors to adjust each strut as the situation requires, enabling it to compensate automatically for body roll and pitch. It also helps to limit squat and dive when accelerating and braking.

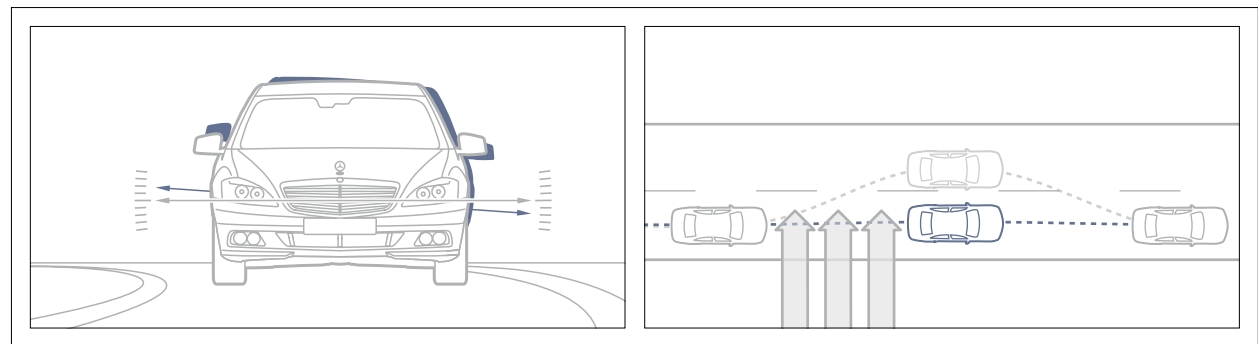

Active Body Control gives the S-Class an even more agile feel. It also compensates for strong crosswinds by adjusting the load distribution between the wheels

In addition, ABC includes a crosswind stabilisation function that compensates for the effect of high winds by redistributing the load between the wheels. Active Body Control is standard on the S 600 L and AMG models and optional on the S 500 BlueEFFICIENCY L.

<sup>1</sup>Not available on S 350 BlueTEC (L) and S 350 BlueEFFICIENCY (L)



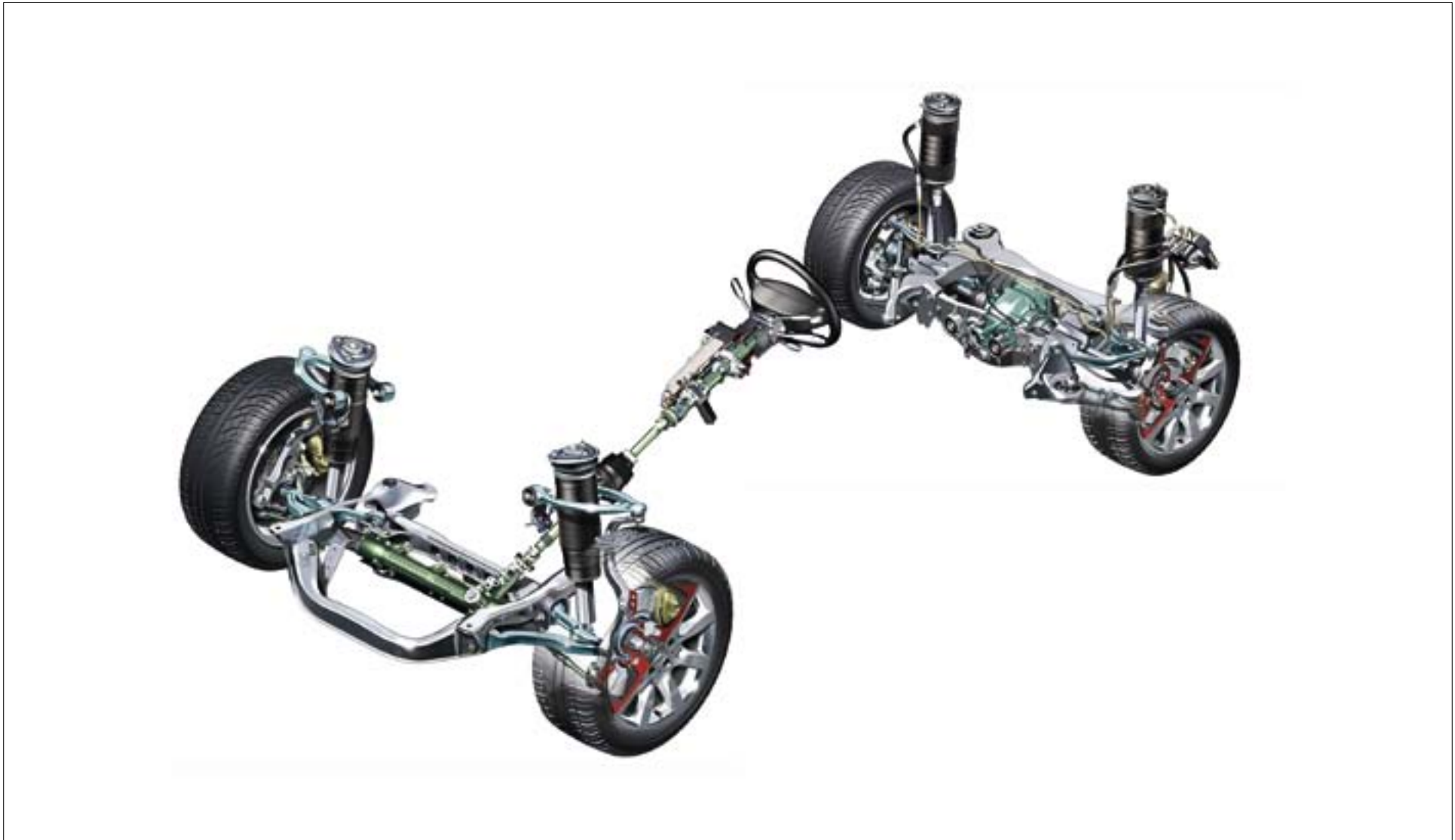

The optional Active Body Control (ABC) suspension in detail



## Integrated safety concept

Like all our passenger cars, the S-Class is built according to an integrated safety concept. It ensures the many passive and active protection systems work together to enhance safety in every situation – helping to bring our vision of accident-free driving another step closer.

As the inventor of the motor car, we feel a particular responsibility towards road safety. That's why we were the first manufacturer to develop an integrated safety concept that seamlessly combines a car's active and passive safety features, thus ensuring optimum all-round protection. This concept covers four different areas – safer driving, anticipating danger, protecting occupants and post-crash safety – and incorporates measures designed to maximise safety in every situation, by helping you to stay safe, alerting you to danger, and assisting you wherever possible. In addition, our unique Pre-Safe® anticipatory safety system recognises likely accident scenarios and takes steps that help to further enhance occupant protection. If a collision can't be avoided, intelligent passive safety systems help to provide protection where it's needed, while solutions that can minimise the consequences of an accident and facilitate emergency assistance are also a key part of this safety concept.

A selection of these technologies for the phases 'safer driving', 'anticipating danger', 'protecting occupants' and 'post-crash safety' are presented on the following pages.

**Safer driving: Attention Assist** (standard). Particularly beneficial on long journeys, Attention Assist is a system for detecting fatigue. Between speeds of approximately 50 and 110 mph, it assesses the driver's behaviour via an array of sensors and registers unexpected changes that may indicate tiredness, such as involuntary movements of the steering wheel.

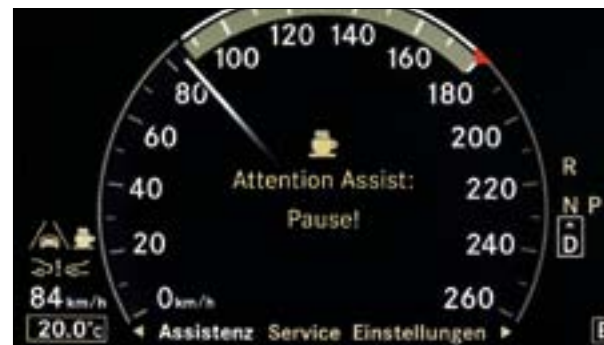

If it detects signs of fatigue, Attention Assist suggests taking a break

**Safer driving: Adaptive High Beam Assist** (standard). Fitted as part of the Intelligent Light System, Adaptive High Beam Assist ensures you enjoy optimum visibility at night without dazzling other drivers. It automatically dips the headlamps when there's oncoming traffic or vehicles ahead and then raises them again when the road is clear. What's more, the transition between main beam and dipped is smooth and almost imperceptible to the driver.

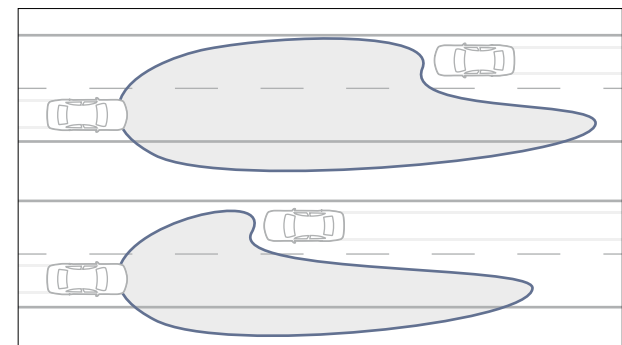

With Adaptive High Beam Assist, the transition between main beam and dipped is almost imperceptible

**Safer driving: Night View Assist Plus** (optional). This infrared camera system captures the entire area that would be illuminated on main beam and shows a black-and-white image in the instrument cluster. In situations where switching to main beam is not appropriate, Night View Assist Plus ensures you have a clearer picture of the road ahead, enabling you to react faster to potentially dangerous situations.

**Safer driving: Driving Assistance Package** (optional). This package comprises a range of intelligent safety technologies. Active Lane-Keeping Assist draws the driver's attention to unintended lane changes, gently vibrating the steering wheel if the S-Class wanders across lane markings. If the driver doesn't react to the warning, the system is able to intervene in order to correct the car's course. Active Blind Spot Assist makes intentional lane changes safer too, using twin radar sensors to watch over the areas not visible in your exterior mirrors. If the sensors spot a vehicle in one of these blind spots, a flashing red

triangle appears in the corresponding mirror, accompanied by an acoustic warning from the instrument panel. Should the driver nevertheless proceed to change lanes, the system can intervene and help prevent a collision by automatically applying the brakes on the appropriate side. DISTRONIC Plus radar-assisted cruise control, meanwhile, enables the S-Class to automatically maintain a preset distance from the vehicle in front, both in high-speed driving and stop/start traffic. Also included in the package are our Brake Assist (BAS Plus) and Pre-Safe® Brake systems – to give that feeling of safety on every trip.

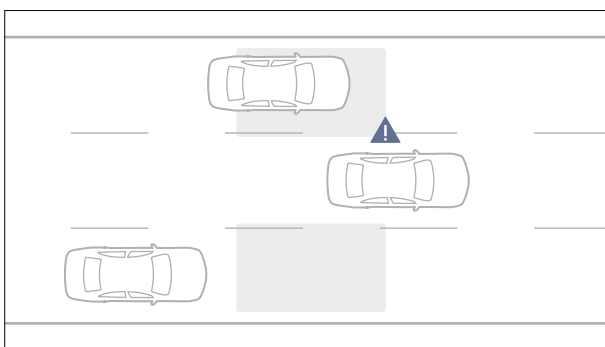

The Driving Assistance Package includes features such as Active Lane-Keeping Assist and Active Blind Spot Assist



Active Blind Spot Assist warns the driver of potentially dangerous lane changes

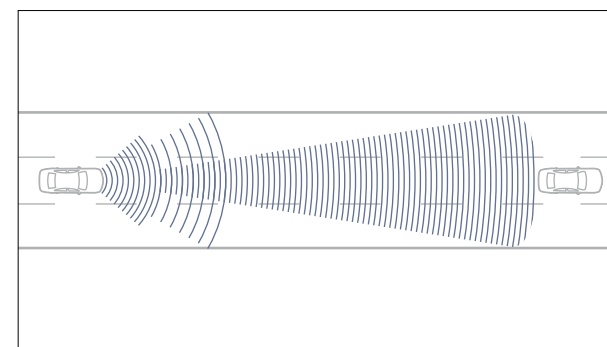

DISTRONIC Plus radar-assisted cruise control helps the driver to maintain a safe distance from the vehicle in front





### Anticipating danger: Pre-Safe® Brake and BAS Plus

(part of optional Driving Assistance Package). If it detects the risk of a collision, Pre-Safe® Brake alerts the driver via visual and audible warnings. At the same time, BAS Plus assesses the brake force required in order to avoid an impact. If the driver applies the brakes but uses insufficient force, BAS Plus automatically raises the braking pressure to a level that exploits the remaining stopping distance to the full, thereby also lessening the likelihood of a shunt from behind.

Should the driver fail to react to Pre-Safe® Brake's warning signals, it slows the car automatically, providing a further warning, and triggers a range of Pre-Safe® measures. If the driver still doesn't respond, the system then initiates autonomous emergency braking, enabling the speed and severity of any impact to be significantly reduced.

**Anticipating danger: Pre-Safe® system (standard).** If it detects a probable accident situation, Pre-Safe® can take anticipatory measures to protect the occupants, such as activating the seat belt tensioners, automatically closing the windows and sunroof (if fitted), and moving the passenger seat to a better position for an impact.

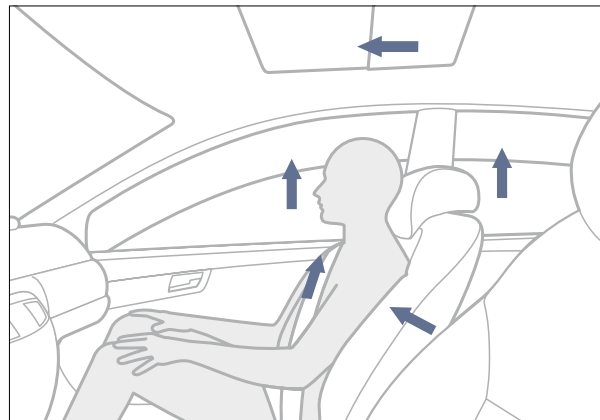

The Pre-Safe® anticipatory safety system can help to reduce the consequences of an accident

### Protecting occupants: Neck-Pro active head restraints

(standard). Fitted to both front seats, the Neck-Pro active head restraints automatically move forwards and upwards in the event of a rear-end collision. This enables them to support the head sooner and reduce strain on the spine.

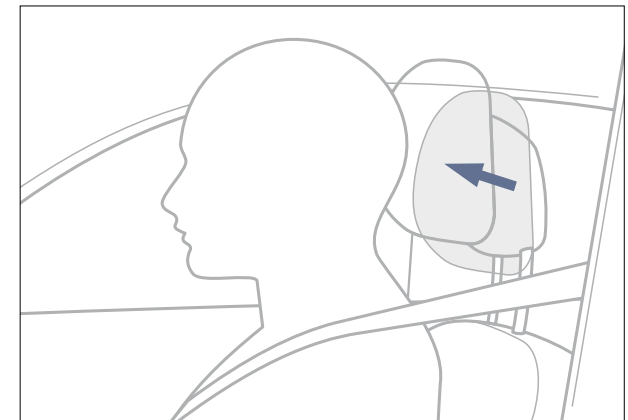

The Neck-Pro active head restraints reduce the risk of whiplash in a rear-end collision



**Protecting occupants: restraint systems** (standard).

In the S-Class, the 3-point seat belts, seat belt tensioners, belt force limiters and airbags are all carefully coordinated so as to keep injuries to a minimum. A total of nine airbags ensure optimum occupant protection, with dual-stage front airbags, four sidebags and two windowbags all fitted as standard. In addition, there's a driver's side kneebag



The nine airbags help to protect you and your passengers in the event of an impact

that helps to reduce the risk of injury to the driver's legs. If the crash sensors detect an impact, the seat belts are instantly tensed, helping to ensure the occupants remain firmly in their seats, while the belt force limiter relaxes the belt as the situation allows, in order to prevent undue force being applied to the rib cage.

**Post-crash safety.** Mercedes-Benz has developed a range of measures that help to minimise the secondary consequences of an accident and facilitate occupant rescue. These include automatic engine cut-off, self-activating hazard lights and emergency cabin lighting. In addition, the central locking system is automatically released in the event of an accident, and there are special crash joints between the front doors and wings that make it easier to open the doors after frontal collisions. In addition, Mercedes-Benz provides a rescue guide for emergency services that can be downloaded from the Internet at [www.mercedes-benz.co.uk/rescueguide](http://www.mercedes-benz.co.uk/rescueguide)



## Multimedia systems

The S-Class comes with COMAND and Bluetooth® connectivity and can be fitted with a choice of optional multimedia technology.

**COMAND multimedia system** (standard). The COMAND system combines telephone, audio and video functions plus hard drive-based navigation in one easy-to-use unit. Its 6-disc DVD changer plays video and audio CDs or DVDs and offers MP3 playback. In addition, COMAND enables you to store up to 2,500 songs on the hard drive and search its music library by title or artist, ensuring you can find the desired track quickly and easily. All information

is presented on a central colour screen, which can even display maps in 3D (three years of map updates are offered free of charge). COMAND also includes a **Media Interface** which allows full integration and control of external media devices.

**Harman Kardon® Front Seat Entertainment Package with SplitView** (optional; standard on S 600 L). The 14-speaker Harman Kardon® Logic 7® surround sound system, which comes as part of the Harman Kardon® Front Seat Entertainment Package, includes a 13-channel DSP amplifier, a DAB digital radio tuner and an integral subwoofer. Specially tailored to the S-Class cabin, it delivers crystal-clear 3D sound in Dolby Digital 5.1. The package also includes the innovative SplitView function. This enables the driver and front seat passenger to view different full-size images on the same screen, meaning the passenger can watch a DVD while the driver continues to use the navigation system.

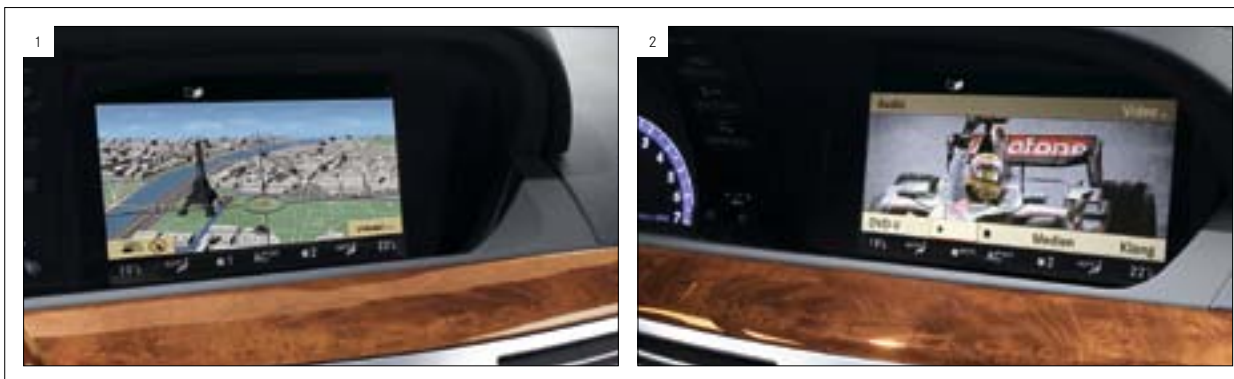

SplitView enables the screen to simultaneously display different images for the driver (1) and the front seat passenger (2)



## Bang & Olufsen BeoSound AMG surround sound system

Enjoy concert-hall surround sound in your S-Class – with the specially developed BeoSound AMG audio system.

The BeoSound AMG system (optional on S 63 AMG L, standard on S 65 AMG L) by Danish audio experts Bang & Olufsen is a masterpiece of acoustic and aesthetic excellence. Its 15 high-performance speakers deliver a total output of 1,200 watts and an exceptionally spacious sound that's more concert hall than car interior. What's more, they look as exclusive as they sound, thanks

to eye-catching matt aluminium speaker and tweeter grilles in all four doors and a matching grille for the rear parcel shelf subwoofer. Illuminated acoustic lenses, with one in each of the front door mirror panels and two rear passenger compartment lenses are integrated into the B-pillars. Using the COMAND multimedia system, the sound can even be focused on the front or rear of

the car, ensuring you enjoy perfect acoustics whether you're driving or being driven. In addition, the closed speaker cabinets enhance sound definition and minimise dispersion, meaning both your music and your hands-free phone calls remain inside the car.



With their high-quality grilles, the Bang & Olufsen speakers look just as good as they sound



The illuminated acoustic lenses are especially striking at night



The sound can be adjusted to suit your listening habits – and your seating position too



## Electronic assistants

Numerous electronic assistants help to make driving the S-Class safer and more relaxing.



The reversing camera's wide-angle lens enables you to see what's immediately behind the car

**The reversing camera** (optional; standard on S 600 L and S 65 AMG L) makes for safer and easier parking manoeuvres. Fitted below the boot lid handle, this wide-angle camera captures the area immediately behind the car and displays the image on the COMAND multimedia system's screen. The camera is activated automatically as soon as the driver engages reverse.



**Advanced Parking Guidance** (standard). By measuring gaps via ultrasound sensors, Advanced Parking Guidance can help the driver manoeuvre into tight spaces. If the sensors detect a suitably sized space, the situation is depicted graphically in the multi-function display. The set of red lines shows the current steering angle, the yellow

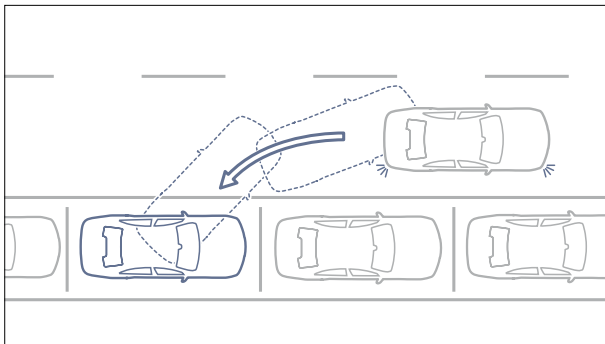

Advanced Parking Guidance assists when manoeuvring

lines represent the required angle. As soon as the two correspond, the lines turn green. In addition, the system will also illustrate the distance from any objects in the car's vicinity when manoeuvring.

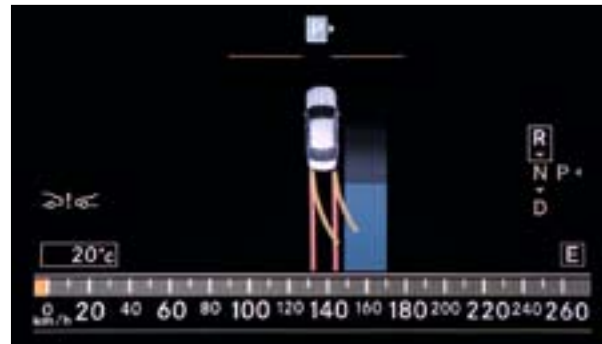

Reassuring support courtesy of Advanced Parking Guidance



## Seats

The S-Class seats offer optimum comfort, ergonomics and safety – and are available with a range of option packages that make the journey even more relaxing.

**Front Seat Comfort Package** (optional).<sup>1</sup> The dynamic multi-contour seats with massage function offer outstanding long-distance comfort. Air chambers in the seats' lumbar and shoulder regions adjust to each occupant's individual body shape, while the side bolsters adapt automatically as you drive to ensure optimum support at all times, especially when cornering. They can even give their occupant a soothing massage. Simply

select one of the massage function's four programmes and let the rolling motion of its seven chambers gently stimulate your back muscles. It's not only highly relaxing, it can also help you feel more focused and alert.

Front comfort head restraints complete this sense of well-being: adjustable for both height and angle, they also feature individually adjustable side bolsters for a snug fit.

**Rear Seat Comfort Package** (optional).<sup>2</sup> Multi-contour seats with massage function adjust to suit the body shape of each individual occupant, deliver relaxing massages and come with comfort head restraints.

**Rear Seat Memory Package** (optional). Fitted together with electric adjustment,<sup>3</sup> the rear seat memory function enables passengers in each of the outer rear seats to store their favourite position and recall it at the touch of a button.



Dynamic multi-contour front seats with massage function



Multi-contour rear seats with massage function

<sup>1</sup> Standard on S 600 L, S 63 AMG L and S 65 AMG L

<sup>2</sup> Standard on S 600 L and S 65 AMG L

<sup>3</sup> Electrically adjustable rear seats are standard on long-wheelbase models

## Luxury automatic climate control

The right cabin climate enhances your comfort and helps you stay focused. The S-Class climate control system features four individually variable temperature zones in the front, with a further two for the rear available as an option.

The S-Class comes with a luxury automatic climate control system that enables the driver and front seat passenger to select their own separate settings. Its sensors monitor the temperature inside and outside the cabin and ensure the preset temperature for each zone is maintained at all times, even in strong sunlight. In addition, there's a choice of three different air flow modes – diffused, medium and focused – and an activated charcoal filter that ensures only

clean air enters the cabin. Front seat occupants can also increase or decrease the air temperature in the footwells independently of their selected temperature settings.

For those in the rear, a two-zone control unit can be added as an option. Situated between the front seat backs, it enables separate temperature and air flow settings to be selected for the left and right side of the

rear passenger compartment. As a result, each occupant can enjoy the right climate for them, ensuring maximum concentration for the driver, plus optimum comfort and safety all round.



Your ideal temperature at the push of a button

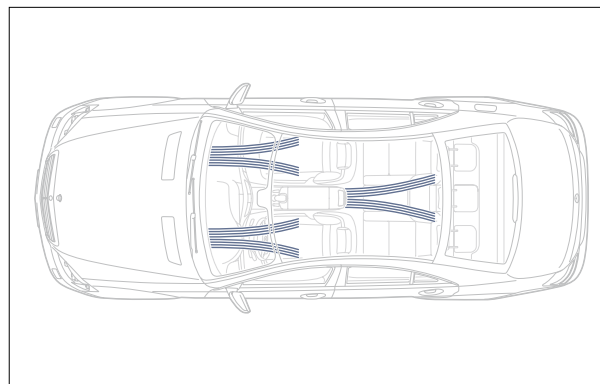

The cabin's independently variable temperature zones





## Long-wheelbase version

For working or relaxing, the long-wheelbase S-Class is the last word in luxury and comfort.

The long-wheelbase S-Class offers even greater legroom and luxury for those in the rear. It not only has an extra 13 centimetres between the axles, it also comes equipped to the very highest standards, with exclusive items such as heated leather seats for the front and rear, electric adjustment for the outer rear seats and a full-width rear

window blind. A tilting /sliding electric sunroof is also fitted as standard.

Among the options are twin individual rear seats, a panoramic glass sunroof, and the Rear Seat Entertainment Package.

Mechanically adjustable folding tables and a second telephone handset in the rear centre armrest can also be added – they turn the long-wheelbase S-Class into a supremely comfortable mobile office.



The long-wheelbase S-Class



Rear seat passengers benefit from extra legroom



## S 600 L

Luxurious appointments and intelligent technology make the S 600 L one of the most relaxing ways to travel.

Even from the outside, exclusive design details set the S 600 L apart, such as a chrome-trimmed grille with three twin louvres, 18" 5-spoke alloy wheels in V12 design and V12 badges on the front wings, as well as model-specific split twin tailpipes and a chrome trim strip at the rear.



The V12 logo appears in the instrument panel on ignition

Inside, sumptuous Exclusive Passion leather upholstery adorns the seats, door centre panels, centre console and dashboard. The A-, B- and C-pillars and roof lining are all trimmed in *designo* Alcantara®, and there's Dark Burr Walnut trim for the doors, dashboard and steering wheel.



The split tailpipe design is exclusive to the S 600 L

Standard equipment for the S 600 L includes dynamic multi-contour front seats and multi-contour rear seats with massage function, reversing camera, Keyless-Go Package and ambient interior lighting with a choice of three colours, plus the Harman Kardon® Logic 7® surround sound system, which is fitted as part of the standard Front Seat Entertainment Package. In addition, this package features the COMAND multimedia system with SplitView and a DAB digital radio tuner.



# S-Guard

S-Class exterior, S-Guard safety: discover armoured protection at its most discreet. → [www.mercedes-benz.co.uk/guard](http://www.mercedes-benz.co.uk/guard)

At first or even second glance, it's indistinguishable from a production model. Under the skin, however, the S-Guard is no ordinary S-Class – it's the ultimate in factory-integrated ballistics protection.

Each S-Guard is assembled on a strictly separated production line that combines high-tech manufacturing with skilled craftsmanship. Here, the S-Class passenger cell is completely reconfigured and an array of safety components inserted to create a unique personal

protection system. In addition, the brakes, suspension and electronic safety systems are all recalibrated to meet the specific needs of the S-Guard.

What's more, the S-Guard not only undergoes the same rigorous quality and safety testing as any Mercedes-Benz, it also has to meet the strict bullet and explosion resistance standards of internationally recognised independent authorities.

All this results in a factory-built armoured vehicle that combines S-Class elegance, refinement and comfort with the very highest levels of personal protection.





Optimum ballistics protection on the move: the S-Guard offers levels of quality and security that can't be achieved by retrofitting armour



## S 63 AMG L

Four-door luxury saloon? Or high-performance sports car? The S 63 AMG L is both. → [www.mercedes-amg.com](http://www.mercedes-amg.com)



The S 63 AMG L: outstanding performance and efficiency meets S-Class luxury

**S 63 AMG L.** The exhilarating S 63 AMG L is powered by a 5.5-litre biturbo AMG V8 that delivers 544 hp (400 kW) and a maximum 800 Nm of torque. Its performance pedigree is obvious long before you turn the key, thanks to AMG bodystyling that includes a muscular front apron with LED daytime running lights and a diffuser-style rear apron. There are also eye-catching 19" AMG 5-triple-spoke design alloy wheels as standard. For an even more dynamic driving experience: the optional AMG Performance Package ups the engine's output to 571 hp (420 kW) and increases peak torque to 900 Nm, while the AMG Performance Studio offers styling options such as 20" AMG forged alloy wheels in polished Titanium Grey.

**AMG 5.5-litre V8.** The S 63 AMG L's biturbo AMG V8 is not just impressively powerful, it's also exceptionally fuel-efficient. Despite delivering 544 hp (400 kW) and 800 Nm – 571 hp (420 kW) and 900 Nm with the optional AMG Performance Package – it achieves a class-leading



26.9 mpg on the combined cycle. This remarkable efficiency is the result of advanced technologies such as direct petrol injection, twin turbochargers and regenerative braking, combined with a transmission featuring a Controlled Efficiency mode with start/stop function. As you'd expect from an AMG engine, this high-tech V8 nevertheless delivers a satisfyingly rich and powerful sound.



The AMG 5.5-litre biturbo V8 offers up to 571 hp (420 kW) and 900 Nm of torque with the optional AMG Performance Package

#### **AMG Speedshift MCT 7-speed sports transmission.**

Like the innovative engine it accompanies, the S 63 AMG L's AMG Speedshift MCT transmission combines the best of both worlds, blending the sporty, direct and involving feel of a manual transmission with the comfort and effortlessness of an automatic. Its Controlled Efficiency, Sport and Manual modes give you a choice of three



AMG sports seats with AMG-design Passion leather upholstery and natural leather side bolsters

different shift styles, while the kickdown function enables the transmission to shift straight from seventh gear to fourth, for instance – allowing you to exploit the engine's performance potential to the full.



AMG sports exhaust system with chromed twin tailpipes



## S 65 AMG L

An exhilarating blend of performance and exclusivity, the S 65 AMG L is the most powerful AMG saloon ever built. → [www.mercedes-amg.com](http://www.mercedes-amg.com)



Breathtaking power and exclusive looks: with its high-performance AMG V12, the S 65 AMG L is the most powerful AMG saloon of all time

**S 65 AMG L.** The S 65 AMG L is the most powerful S-Class and the most powerful AMG saloon of all time, with 630 hp (463 kW) plus 1,000 Nm of torque from its 6.0-litre biturbo AMG V12. The result is truly exhilarating performance, with 0 to 62 mph taking just 4.4 seconds. Channelling all that power to the road is the AMG Speedshift 5-speed automatic transmission. In addition to effortless automatic shifts, it gives you the option of



The AMG sports steering wheel and AMG instrument panel



changing gear manually via the AMG sports steering wheel's aluminium shift paddles.

From the outside, 20" forged AMG alloy wheels in Titanium Grey set the S 65 AMG L apart, along with an AMG sports exhaust system featuring two sets of AMG V12-specific twin tailpipes. For an even more exclusive look, simply add options from the AMG Performance Studio.



AMG Black Piano Lacquer/Carbon-fibre interior trim, available from the AMG Performance Studio



AMG sports seats upholstered in Exclusive Passion leather with AMG V12-specific diamond stitching





## Standard equipment | Selection



Nappa leather-trimmed multi-function steering wheel<sup>1</sup>



Attention Assist



6-disc CD/DVD changer and SD card slot



COMAND multimedia system with colour display



Bluetooth® connectivity in COMAND

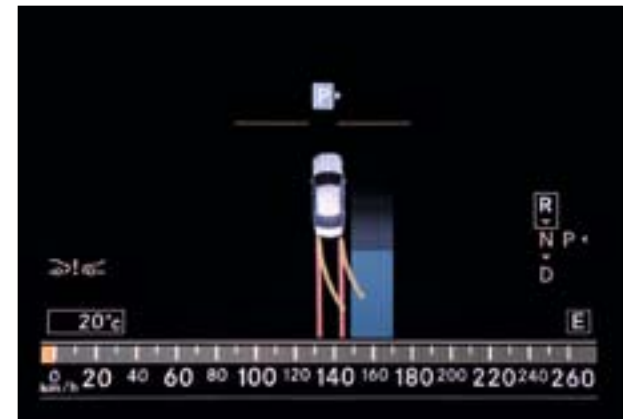

Advanced Parking Guidance

<sup>1</sup>Not available on S 600 L



## Optional extras | Selection



Rear Seat Entertainment Package



Folding rear work tables



Panoramic glass sunroof

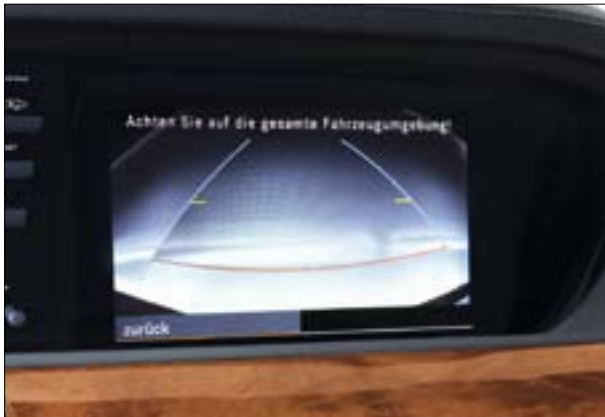

Reversing camera<sup>2</sup>



Keyless-Go<sup>2</sup>



Front seat memory<sup>3</sup>

<sup>2</sup>Standard on S 600 L and S 65 AMG L <sup>3</sup>Standard on S 500 BlueEFFICIENCY L, S 600 L, S 63 AMG L and S 65 AMG L

Individual features may be part of option packages and therefore may not be available as stand-alone options



## AMG Sports Package

The optional AMG Sports Package makes for an even more eye-catching S-Class. → [www.mercedes-benz.co.uk](http://www.mercedes-benz.co.uk)

The AMG Sports Package<sup>1</sup> lends the S-Class a highly dynamic look. Its AMG bodystyling comprises AMG front and rear aprons plus side skirts, and the package



Black Ash wood trim

also adds burnished 19" AMG 5-spoke alloy wheels. Alternatively, 20" AMG 5-twin-spoke alloy wheels are available as a separate option.



The striking AMG bodystyling rear apron

Other additions include painted brake calipers with 'Mercedes-Benz' lettering and larger perforated brake discs for V6 models. Inside, there's Black Ash wood<sup>2</sup> interior trim, a wood- and leather-trimmed steering wheel, AMG velour floor mats and brushed stainless steel sports pedals.

<sup>1</sup>Not available for S 63 AMG L and S 65 AMG L

<sup>2</sup>Alternative trims available: Dark Burr Walnut, Light Burr Walnut, Dark Brown Eucalyptus and *designo* wood trim





The AMG Sports Package gives the S-Class a more dynamic look



## *designo*

Exclusive colours, exquisite upholsteries and the finest interior trim: *designo* options add an extra touch of individuality to your S-Class.

→ [www.mercedes-benz.co.uk/designo](http://www.mercedes-benz.co.uk/designo)

With beautifully crafted materials and a wide variety of colours, the *designo* range offers almost endless possibilities. Eye-catching *designo* paint finishes add an exclusive touch to the exterior. For the interior, there's *designo* Exclusive Aniline leather, complemented by carefully matched wood trim such as Black Piano Lacquer, with a gloss finish applied in up to ten layers,

or stone trims made of finely cut Norwegian granite. All *designo* S-Class upholsteries feature 10-rib vertical fluting and metal *designo* backrest badges, while the wood- and leather-trimmed steering wheel and Alcantara® roof lining further enhance the air of refinement.



Light Brown *designo* Exclusive Aniline leather upholstery (X35) combined with *designo* Natural Maple Grain wood trim (W64)



*designo* Natural Maple Grain wood trim (W64)



## *designo* Selection

Luxurious appointments and intelligent technology make the S 600 L one of the most relaxing ways to travel.

There are two different ways to give your long-wheelbase S-Class the *designo* touch. You can create your own ideal combination from the wide range of high-quality appointments, or make the decision easier with *designo* Selection, an option package that brings together all the most exclusive *designo* appointments.

In addition to your choice of *designo* exterior colour (*designo* metallic, *designo* Mystic or *designo* Magno), it adds *designo* Exclusive Aniline leather upholstery in your chosen colour, plus *designo* wood trim and a matching *designo* wood- and leather-trimmed steering wheel. The package also includes a roof lining in fluted *designo* Black nappa leather and a *designo* badge in solid 18-carat

gold. Whether you opt for a harmonious colour scheme or striking contrasts, *designo* Selection makes a long-wheelbase S-Class even more special.

In the *designo* section of our website, you can browse through the colours and materials available and try out possible combinations.



*designo* Exclusive Aniline leather in Porcelain (X27) with *designo* Black Piano Lacquer trim (W69)



*designo* logo in solid 18-carat gold



## Upholstery and trim

Tailor the S-Class interior to your tastes – with your choice of colours, upholstery and fine wood trim.



Contrast top-stitching on the glove compartment

**Passion Leather Package.** This optional interior package for long-wheelbase models (standard on S 63 AMG L<sup>1</sup>) comprises fine Passion leather upholstery with contrast top-stitching for the seats and armrests, plus high-quality Artico artificial leather with contrast top-stitching for the dashboard and door centre panels.

**Exclusive Passion Leather Package.** For an even more luxurious look, there's the Exclusive Passion Leather Package for long-wheelbase models (standard on S 600 L and S 65 AMG L). In addition to Passion leather upholstery with contrast top-stitching for the seats and armrests, it features fine Passion leather with contrast top-stitching for the dashboard, door centre panels, seat pockets, map pockets and parcel shelf, plus high-quality Alcantara® for the roof lining and trim on the A-, B- and C-pillars.

<sup>1</sup>Not available on S 65 AMG L





The Black/Black interior scheme features either standard leather or optional Passion leather upholstery, with black carpets and cabin trim (door, dashboard, centre console and steering wheel trim). For the long-wheelbase version, there's the option of the Passion Leather Package or the Exclusive Passion Leather Package.

#### Black/Black

211	Leather
821	Passion Leather
821+U09	Passion Leather Package
901	Exclusive Passion Leather Package
911	Exclusive Passion Leather Package (V12 models only)

#### Trim

H15	Dark Brown Eucalyptus wood (standard) <sup>1</sup>
731	Dark Burr Walnut wood (gloss finish) <sup>2</sup>
H14	Light Burr Walnut wood (gloss finish)
H18	Brown Poplar wood (V12 models only)
736	Black Ash wood <sup>3</sup>

<sup>1</sup>Excluding S 600 L and S 65 AMG L  
<sup>2</sup>Standard on S 600 L and S 65 AMG L  
<sup>3</sup>Standard with AMG Sports Package



211  
821  
821+  
U09  
901  
911



H15



731



H14



H18



736







The Alpaca Grey/Basalt Grey interior scheme features Alpaca Grey leather upholstery, with matching door panels, lower dashboard trim, centre console and carpets. The steering wheel, upper dashboard trim and door caps come in Basalt Grey. As an option, this colour scheme is also available with Passion leather or with the Passion Leather Package or Exclusive Passion Leather Package (long-wheelbase versions).

#### Alpaca Grey/Basalt Grey

218	Leather
828	Passion Leather
828+U09	Passion Leather Package
908	Exclusive Passion Leather Package
918	Exclusive Passion Leather Package (V12 models only)

#### Trim

H15	Dark Brown Eucalyptus wood (standard) <sup>1</sup>
731	Dark Burr Walnut wood (gloss finish) <sup>2</sup>
H14	Light Burr Walnut wood (gloss finish)
H18	Brown Poplar wood (V12 models only)
736	Black Ash wood <sup>3</sup>

<sup>1</sup>Excluding S 600 L and S 65 AMG L

<sup>2</sup>Standard on S 600 L and S 65 AMG L

<sup>3</sup>Standard with AMG Sports Package

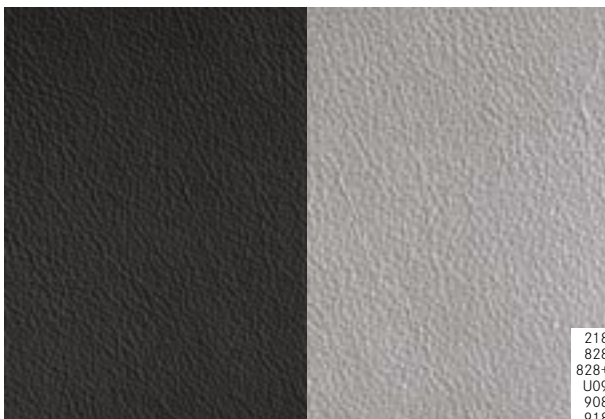



The Cashmere Beige/Savanna Beige interior scheme features Cashmere Beige leather upholstery, with matching door panels, lower dashboard trim, centre console and carpets. The steering wheel, upper dashboard trim and door caps come in Savanna Beige. As an option, this colour scheme is also available with Passion leather or with the Passion Leather Package or Exclusive Passion Leather Package (long-wheelbase versions).

#### Cashmere Beige/Savanna Beige

214	Leather
824	Passion Leather
824+U09	Passion Leather Package
904	Exclusive Passion Leather Package
914	Exclusive Passion Leather Package (V12 models only)

#### Trim

H15	Dark Brown Eucalyptus wood (standard) <sup>1</sup>
731	Dark Burr Walnut wood (gloss finish) <sup>2</sup>
H14	Light Burr Walnut wood (gloss finish)
H18	Brown Poplar wood (V12 models only)
736	Black Ash wood <sup>3</sup>

<sup>1</sup>Excluding S 600 L and S 65 AMG L

<sup>2</sup>Standard on S 600 L and S 65 AMG L

<sup>3</sup>Standard with AMG Sports Package



214  
824  
824+  
U09  
904  
914



H15

731

H14

H18

736





The Sahara Beige/Black interior scheme features Sahara Beige leather upholstery, with matching door panels, lower dashboard trim, centre console and carpets. The steering wheel, upper dashboard trim and door caps come in Black. As an option, this colour scheme is also available with Passion leather or with the Passion Leather Package or Exclusive Passion Leather Package (long-wheelbase versions).

#### Sahara Beige/Black<sup>1</sup>

275	Leather
885	Passion Leather
885+U09	Passion Leather Package
955	Exclusive Passion Leather Package
965	Exclusive Passion Leather Package (V12 models only)

#### Trim

H15	Dark Brown Eucalyptus wood (standard) <sup>1</sup>
731	Dark Burr Walnut wood (gloss finish) <sup>2</sup>
H14	Light Burr Walnut wood (gloss finish)
H18	Brown Poplar wood (V12 models only)
736	Black Ash wood <sup>4</sup>

<sup>1</sup> Not available for S 63 AMG L and S 65 AMG L

<sup>2</sup> Excluding S 600 L and S 65 AMG L

<sup>3</sup> Standard on S 600 L and S 65 AMG L

<sup>4</sup> Standard with AMG Sports Package

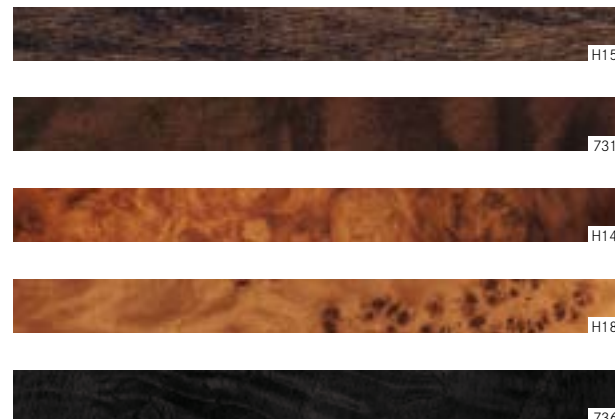
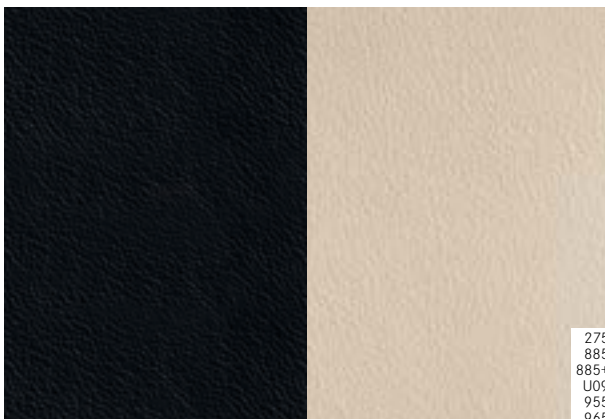



The Chestnut Brown/Black interior scheme features Chestnut Brown leather upholstery, with matching door panels, lower dashboard trim, centre console and carpets. The steering wheel, upper dashboard trim and door caps come in Black. As an option, this colour scheme is also available with Passion leather or with the Passion Leather Package or Exclusive Passion Leather Package (long-wheelbase versions).

#### Chestnut Brown/Black<sup>1</sup>

274	Leather
884	Passion Leather
884+U09	Passion Leather Package
954	Exclusive Passion Leather Package
964	Exclusive Passion Leather Package (V12 models only)

#### Trim

H15	Dark Brown Eucalyptus wood (standard) <sup>1</sup>
731	Dark Burr Walnut wood (gloss finish) <sup>2</sup>
H14	Light Burr Walnut wood (gloss finish)
H18	Brown Poplar wood (V12 models only)
736	Black Ash wood <sup>4</sup>

<sup>1</sup> Not available for S 63 AMG L and S 65 AMG L

<sup>2</sup> Excluding S 600 L and S 65 AMG L

<sup>3</sup> Standard on S 600 L and S 65 AMG L

<sup>4</sup> Standard with AMG Sports Package

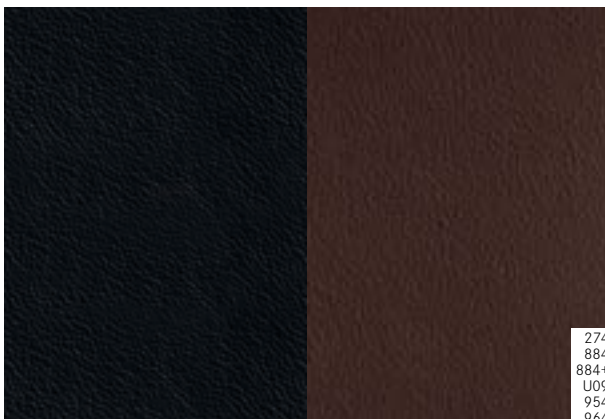

274  
884  
884+  
U09  
954  
964



H15

731

H14

H18

736



## Alloy wheels



18" 5-spoke alloy wheels (standard on S 350 BlueTEC (L), S 350 BlueEFFICIENCY (L) and S 500 BlueEFFICIENCY (L))



18" 15-spoke alloy wheels (optional)



19" 5-spoke alloy wheels (optional)



18" 5-spoke V12 design alloy wheels (standard on S 600 L)



18" 7-twin-spoke burnished alloy wheels (optional)



19" multi-spoke alloy wheels (optional)





19" 5-Y-spoke alloy wheels (optional)



19" AMG 5-spoke alloy wheels with high-sheen finish (optional, only with AMG Sports Package)



20" AMG 5-twin-spoke alloy wheels (optional)



19" AMG 5-triple-spoke alloy wheels with high-sheen finish (standard on S63 AMG L)



20" AMG 5-twin-spoke alloy wheels (standard on S65 AMG L, optional on S63 AMG L)



## Retailer-fit accessories

A Mercedes-Benz is not just a car, it's a travel companion that can be tailored to your needs – with our wide range of Retailer-fit accessories.

→ [www.mercedes-benz.co.uk/accessories](http://www.mercedes-benz.co.uk/accessories)

Our Retailer-fit accessories offer you a range of ways to increase the practicality and individuality of your S-Class. If your S-Class is ever stolen, fitting a Tracker™ will put your mind at rest. With VHF (Very High Frequency) technology,

your vehicle can be located even if it's held in a garage or an underground car park. There's also a variety of cargo-carrying accessories that enable your S-Class to meet all your leisure needs with ease. Up to six pairs of skis or

four snowboards can be safely accommodated on the New Alustyle 'Comfort' ski and snowboard rack, for instance. This is designed for use in conjunction with our Alustyle roof bars and features a practical pull-out function



Tracker™



Coat hanger



The practical New Alustyle 'Comfort' ski and snowboard rack



for easier loading and unloading. You can even go online in your S-Class – with the Retailer-fit InCar Hotspot. It provides internet access via the car's external aerial and enables you to connect up to four laptops or other



The Mercedes-Benz InCar Hotspot

wi-fi devices at the same time. If you own an S-Class, it deserves to be cherished. Should your vehicle be parked up for any length of time, our AMG-branded indoor cover will protect the bodywork from scratches and dust.



Chromed door handle recesses



AMG indoor car cover





## Services

**Test drive.** Words can only do so much. Some things have to be experienced to be truly appreciated. Which is why we'd like to invite you for a test drive. Feel the power of efficient engines that offer impressive fuel consumption. Feel exhilarated by precise steering, designed to connect the driver with the road and enjoy sumptuous levels of comfort. Your Mercedes-Benz Retailer will be happy to make arrangements for you to experience the things that set a Mercedes-Benz apart. Alternatively, to request a test drive online simply visit [www.mercedes-benz.co.uk/testdrive](http://www.mercedes-benz.co.uk/testdrive). We look forward to seeing you.

**Mercedes-Benz Finance.** At Mercedes-Benz Finance, our single-minded aim is to provide optimum financial solutions for all those who share the Mercedes-Benz philosophy of absolute commitment to quality. Whether you are a private customer or a business user, our finance and leasing packages can be tailored to meet your individual

needs. For further information on Mercedes-Benz Finance, please contact your local Mercedes-Benz Retailer.

**Mercedes-Benz Insurance** offers a fully comprehensive 5 star<sup>1</sup> Motor Insurance policy specifically designed to give you the cover you would expect from Mercedes-Benz. For a quotation, please call 0845 600 2180?

**Factory Collection.** What can possibly heighten the experience of taking possession of your brand new Mercedes-Benz? The highlight might just be to see and experience where it was built in Stuttgart, and to take the long way home by driving it through some of Europe's most beautiful countryside. The Mercedes-Benz



Factory Collection offers just that. Included in the Collection is an airport transfer to your hotel, one night's accommodation for one person with dinner and breakfast, a tour of the Mercedes-Benz factory, five days fully comprehensive insurance, and a return crossing by Eurotunnel (Standard Class). All you will need to pay for is your one-way flight to Germany. For more information, please contact your local Retailer, the Mercedes-Benz Factory Collection team on 0845 273 9705 or visit [www.mercedes-benz.co.uk/factorycollection](http://www.mercedes-benz.co.uk/factorycollection)

**Interactive Owner's Manual.** The website also offers an interactive tour, enabling you to take a closer look at your desired model. This simulation is the ideal way to acquaint yourself with your dream car. You can view key functions in detail, gain an insight into the car's inner workings or look at the benefits of each model. For further details, visit [www.mercedes-benz.co.uk/sclassmanual](http://www.mercedes-benz.co.uk/sclassmanual)



**Roadside Assistance.** Rest assured that should you ever need help, Mercedes-Benz Roadside Assistance is there for you. In the unlikely event of a technical breakdown<sup>3</sup> you can rely on the Mercedes-Benz Roadside Assistance Team – anywhere in Europe. Simply phone our Customer Assistance Centre on 00800 1 777 7777,<sup>4</sup> where our specialists will organise assistance for you. Mercedes-Benz will also assist you in the event of a minor mishap preventing you from driving your vehicle.<sup>3</sup> Whether you lose your key, run out of fuel or your vehicle is damaged due to an accident or vandalism, Mercedes-Benz ensures that you still reach your destination. Often the problem can be rectified on the spot, but if this is not possible, we will naturally ensure that your vehicle is taken to the nearest Mercedes-Benz Official Workshop to get you back on the road as quickly as possible.

<sup>1</sup> As rated by Defaqto, a leading UK independent financial research company.  
Mercedes-Benz Motor Insurance is underwritten by Aviva Insurance Limited  
<sup>2</sup> Calls are charged at local rate and may be recorded

**Mercedes-Benz World at Brooklands.** Celebrate the story of Mercedes-Benz and you'll celebrate the story of motoring itself at Mercedes-Benz World in Surrey. A World of experiences. Discover Mercedes-Benz racing heritage, from its connections to the famous Brooklands circuit through to present-day Formula 1™ brought to life in the most sensational way. View, touch and sit in every car from the Mercedes-Benz range, and encounter automotive legends like the 'Gullwing' and many other classic icons, in the UK's largest Mercedes-Benz showcase. Then set your pulse racing by booking one of our thrilling Driving Experiences. Enjoy AMG performance on the purpose-built Handling Circuits or Wet Skid Circle, an axle-twisting off-road adventure, or treat your kids over 1.5 metres tall to their own driving experience in an A-Class or on the off-road terrain in an M-Class.

<sup>3</sup> Cover is initially valid for your vehicle for four years from the date of first registration. This can be extended from the fifth year, up to a maximum of 30 years, on completion of each scheduled maintenance service, providing that this service is carried out by a Mercedes-Benz

And for kids even younger and under 1.3 metres tall, let them be a 'Little Learner' in their own miniature electric version of the desirable Mercedes-Benz SL. For more interactive action, take a virtual 3D journey along the production line in 'Build' and take a seat in the cinema to accelerate from the birth of the car to the latest innovations in 20 eye-opening minutes.

Relax and refuel in Café 1886, or for something more enjoy the delicious menu and elegant surroundings of the Gullwing Restaurant. Finally, extend your visit with a short stroll to Brooklands Museum to see their collection of classic cars, aviation exhibitions – and the legendary Concorde. For more information visit [www.mercedes-benzworld.co.uk](http://www.mercedes-benzworld.co.uk)

Official Workshop. Minor mishap cover is provided at the absolute discretion of Mercedes-Benz  
<sup>4</sup>In non-affiliated European countries: +44 20 7975 7077



# Following the star

## S-Class

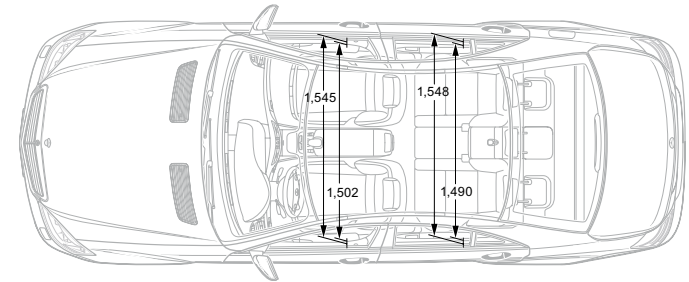
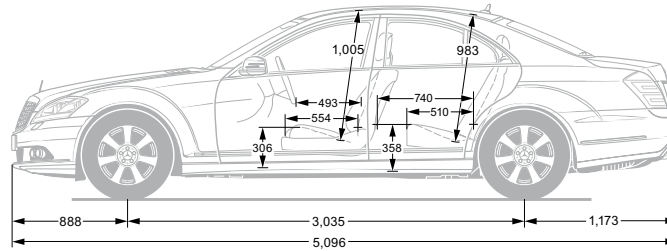
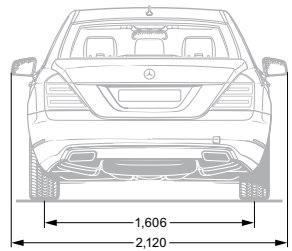

## S-Class long-wheelbase version

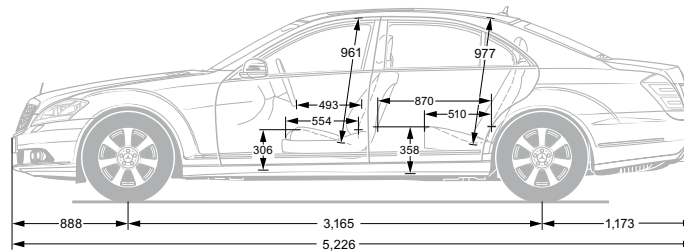
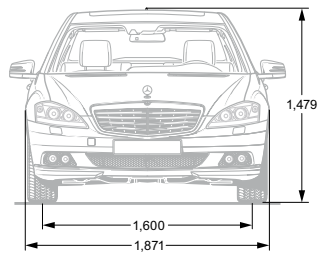

All measurements in millimetres. The dimensions shown are mean values and apply to standard-specification, unladen vehicles

<sup>1</sup>Available at additional cost



# Technical data

	Diesel engine	Petrol engines	
	S 350 BlueTEC S 350 BlueTEC L	S 350 BlueEFFICIENCY S 350 BlueEFFICIENCY L	S 500 BlueEFFICIENCY L
No. of cylinders/arrangement	V6	V6	V8
Total displacement – cc	2,987	3,498	4,663
Rated output <sup>1</sup> – hp (kW) at rpm	258 (190)/3,600	306 (225)/6,500	435 (320)/5,250
Rated torque <sup>1</sup> – Nm at rpm	620/1,600–2,400	370/3,500	700/1,800–3,500
Compression ratio	15.5	12.0	10.5
Acceleration 0–62 mph – sec (long wheelbase)	7.1 (7.1)	6.9 (7.1)	(5.0)
Top speed approx. – mph (long wheelbase)	155 <sup>3</sup> (155 <sup>3</sup> )	155 <sup>3</sup> (155 <sup>3</sup> )	(155 <sup>3</sup> )
Tyre size – front	255/45 R 18	255/45 R 18	255/45 R 18
rear	255/45 R 18	255/45 R 18	255/45 R 18
Fuel consumption <sup>4</sup> – mpg			
Urban (long wheelbase)	36.7 (36.7)	27.7 (27.4)	(21.9)
Extra-urban (long wheelbase)	52.3 (52.3)	47.1 (46.3)	(38.7)
Combined (long wheelbase)	45.6 (45.6)	37.2 (36.7)	(30.1)
CO <sub>2</sub> emissions, combined <sup>4</sup> – g/km (long wheelbase)	164–168 (164–168)	177–184 (179–186)	(219–224)
EU emissions standard	EU6	EU5	EU5
Fuel tank capacity/reserve (approx.) – l	83/11	83/11	83/11
Boot capacity – l	560	560	560
Turning circle – m (long wheelbase)	11.8 (12.2)	11.8 (12.2)	(12.2)
Kerb weight <sup>5</sup> – kg (long wheelbase)	1,995 (2,070)	1,910 (1,975)	(2,075)
Perm. GVW – kg (long wheelbase)	2,590 (2,650)	2,505 (2,555)	(2,655)

<sup>1</sup>Figures according to Directive 80/1269/EEC in the currently applicable version <sup>2</sup>In conjunction with optional AMG Performance Package <sup>3</sup>Electronically limited <sup>4</sup>The figures shown were obtained in accordance with the prescribed measuring process (Regulation [EC] 715/2007 in the currently applicable version). The figures are not based on an individual vehicle and do not constitute part of the product offer; they are provided solely for purposes of comparison between different vehicle models

<sup>5</sup>Figures according to Directive 92/21/EC, version 95/48/EC (kerb weight with fuel tank 90% full, driver, 68 kg, and luggage, 7 kg) for standard-specification vehicles. Optional extras and accessories will generally increase this figure and reduce the payload capacity accordingly



	Petrol engines		
	S 600 L	S 63 AMG L	S 65 AMG L
No. of cylinders/arrangement	V12	V8	V12
Total displacement – cc	5,513	5,461	5,980
Rated output <sup>1</sup> – hp (kW) at rpm	517 (380)/5,000	544 (400)/5,250–5,750 [571 (420)/5,500 <sup>2</sup> ]	630 (463)/4,600–5,000
Rated torque <sup>1</sup> – Nm at rpm	830/1,800–3,500	800/2,000–4,500 [900/2,250–3,750 <sup>2</sup> ]	1,000/2,300–4,300
Compression ratio	9.0	10.0	9.0
Acceleration 0–62 mph – sec (long wheelbase)	(4.6)	(4.5) [4.4 <sup>2</sup> ]	(4.4)
Top speed approx. – mph (long wheelbase)	(155 <sup>3</sup> )	(155 <sup>3</sup> ) [186 <sup>2</sup> ]	(155 <sup>3</sup> )
Tyre size – front	255/45 R18	255/40 ZR19	255/35 ZR20
rear	275/45 R18	275/40 ZR19	275/35 ZR20
Fuel consumption <sup>4</sup> – mpg			
Urban (long wheelbase)	(13.1)	(19.6)	(13.0)
Extra-urban (long wheelbase)	(29.1)	(34.4)	(28.5)
Combined (long wheelbase)	(20.0)	(26.9)	(19.8)
CO <sub>2</sub> emissions, combined <sup>4</sup> – g/km (long wheelbase)	(329–332)	(244)	(334)
EU emissions standard	EU5	EU5	EU5
Fuel tank capacity/reserve (approx.) – l	90/11	90/14	90/14
Boot capacity – l	550	560	550
Turning circle – m (long wheelbase)	(12.2)	(12.2)	(12.2)
Kerb weight <sup>5</sup> – kg (long wheelbase)	(2,210)	(2,170)	(2,275)
Perm. GVW – kg (long wheelbase)	(2,690)	(2,695)	(2,710)

<sup>1</sup>Figures according to Directive 80/1269/EEC in the currently applicable version <sup>2</sup>In conjunction with optional AMG Performance Package <sup>3</sup>Electronically limited <sup>4</sup>The figures shown were obtained in accordance with the prescribed measuring process (Regulation [EC] 715/2007 in the currently applicable version). The figures are not based on an individual vehicle and do not constitute part of the product offer; they are provided solely for purposes of comparison between different vehicle models

<sup>5</sup>Figures according to Directive 92/21/EC, version 95/48/EC (kerb weight with fuel tank 90% full, driver, 68 kg, and luggage, 7 kg) for standard-specification vehicles. Optional extras and accessories will generally increase this figure and reduce the payload capacity accordingly

## Paint finishes

The innovative Mercedes-Benz paint system features one of the finest clearcoats of any manufacturer. Its exceptionally dense molecular structure makes the paintwork more durable and lends it a deeper, more lasting sheen, helping your S-Class to retain both its looks and its long-term value.

---

### Non-metallic paint (standard)

---

040 Black

---

### Metallic paints (optional)

---

183 Magnetite Black

197 Obsidian Black

300 Periclase Green

370 Andorite Grey

474 Peridot Brown

526 Dolomite Brown

544 Carneol Red

775 Iridium Silver

792 Palladium Silver

799 Diamond White<sup>1</sup>

890 Cavansite Blue

---

For details of *designo* exterior colours, please visit

[www.mercedes-benz.co.uk/designo](http://www.mercedes-benz.co.uk/designo)

### Non-metallic paint



### Metallic paints



<sup>1</sup>Available at additional cost



**Take-back of end-of-life vehicles. Coming full circle.** At the end of its long life, you can return your S-Class to us for environment-friendly disposal in accordance with the EC End-of-Life Vehicle Directive.<sup>1</sup> But that day lies a long way off.

<sup>1</sup>Applies in accordance with national regulations to vehicles up to 3.5t permissible gross weight. The S-Class has met the statutory regulations governing the suitability of the vehicle's design for reuse and recycling for a number of years now. A network of vehicle take-back depots and dismantlers has been established which will process your vehicle in an environment-friendly manner. The ways in which both vehicles and parts can be recovered are subject to ongoing development and improvement. Consequently, the S-Class will be able to comply with any future increases in the recycling quota within the stipulated time limits. Further information is available at [www.mercedes-benz.co.uk](http://www.mercedes-benz.co.uk) or by calling 0808 156 6606.

**Please note:** this online version of the printed brochure may contain abridged copy or other content changes. The manufacturer reserves the right to make changes to the design, form, colour and specification during the delivery period, provided these changes, while taking into account the interests of the vendor, can be deemed reasonable with respect to the purchaser. Where the vendor or the manufacturer uses symbols or numbers to describe an order or the subject of an order, no rights may be derived solely from these. The illustrations may show accessories and items of optional equipment which are not part of standard specification. Colours may differ slightly from those shown in the brochure, owing to the limitations of the printing process. This brochure has been compiled by Daimler AG of Germany and is distributed internationally. It provides a general indication of the range of models, features, optional extras and/or colours available in various countries. Some of the models, features, optional extras and/or colours shown may not be available in your country, or may only be available in a different specification. Additionally some models, features, optional extras and/or colours may only be available in combination with others. For current and more specific information in relation to the range of models, features, optional extras and/or colours available in your country, and their pricing, you should contact your nearest authorised Mercedes-Benz Retailer. E&OE. [www.mercedes-benz.co.uk](http://www.mercedes-benz.co.uk)

