



Das Auto.

The Passat and Passat Estate



Contents.

04	Design
09	Interior
14	Driver's assistance systems
16	Radio and navigation systems
24	Passat and Passat Estate S
26	New Passat and Passat Estate BlueMotion
28	Passat and Passat Estate SE and SE Business
30	Passat and Passat Estate GT
32	New Passat Alltrack
34	Passat and Passat Estate R-Line
36	Alloy wheels
38	Think Blue
40	Paint
42	Upholstery
44	Combinations
50	Technical specification
57	Technology
58	Dimensions
60	CO ₂ emissions and VED bands with optional wheels
62	Volkswagen service



Models shown are Passat Estate GT 2.0 BiTDI 240 PS 4MOTION and Passat GT 2.0 BiTDI 240 PS 4MOTION with optional 19" 'Verona' alloy wheels and metallic paint.

The Passat. Refined, advanced, elegant.

Confident, charismatic and sophisticated, everything about the Passat and Passat Estate exudes confidence. Making its appearance as the eighth generation of a best-selling car that has sold nearly 22 million models since 1973, the Passat features advanced technologies and sophisticated assistance systems, providing new levels of comfort, luxury and performance. And that's not all. The innovative lightweight design combined with sustainable engine technology reduces emissions, operating costs and fuel consumption to new low levels, benefiting both the environment and your pocket.

With its cutting-edge design, technologies and engines, the Passat and Passat Estate are as versatile, progressive and sophisticated as you could wish for.



Model shown is Passat GT 2.0 BiTDI 240 PS 4MOTION with optional 19" 'Verona' alloy wheels and metallic paint.



Model shown is Passat Estate GT 2.0 BiTDI 240 PS 4MOTION with optional 19" 'Verona' alloy wheels, panoramic sunroof and metallic paint.

The shape of success.

Engineering and design sets a new benchmark in the Passat and Passat Estate. Sharp styling includes a longer wheelbase, shorter body overhangs and a dynamic silhouette with distinctive tornado line, accented by trapezoidal headlights and rear lights, creating an imposing road presence. The redesigned interior complements the sophisticated exterior, with a host equipment and advanced features providing sublime levels of comfort, convenience and luxury. Inside and out, this is functionality at its most stunning: sleek, stylish and dynamic.



Interior shown is Passat Estate GT with optional smoking pack, net partition and metallic paint.

Sitting comfortably? Then your journey can begin.

However long or short your journey, you'll always sit comfortably in the Passat. Stylish, durable and ergonomically designed to provide maximum comfort and support, seats are available in a range of contemporary upholsteries and leathers. Standard front seats provide manual height and lumbar adjustment, while SE models and above feature the awarded ergoComfort front seat for the driver, providing lumbar support, seat cushion tilt adjustment, thigh support and electric backrest adjustment, enabling you to find the optimum position for your spine easily and quickly. With the spacious interior providing more head and legroom than ever before, there's plenty of room for family, friends and equipment, especially in the Passat Estate. School run, weekend away or driving to work, driving has never been so easy or relaxed.

More space. More versatility. More possibilities.

Whether you're taking a business trip or going on a major shopping expedition, the Passat and Passat Estate are designed to meet your every need. Optional keyless entry includes hands free boot or tailgate opening, which opens the boot or tailgate remotely, ideal if your hands are full, while the variable boot floor is height adjustable and removable, providing plenty of room for all your equipment or purchases. In the Passat Estate, the load volume increases to a massive 1,780 litres with the back seats folded down, providing all the space you could ask for. Versatile, flexible and more spacious than ever, you can rely on the Passat to keep you organised.



01 Integrated child seats* are convenient, practical and easy to use, available for children weighing 15 – 36kg and up to 1.5m tall. Designed to provide optimal side support, they help ensure the safety of small occupants. Optional on all models. Image shown features optional 'Nappa' leather.

02 – 04 To extend the boot space, simply release the rear seat backrest either from the boot or the rear seat. The **variable boot floor** helps facilitate loading and unloading, while the optional cargo management system or optional luggage compartment divider pack keeps luggage secure. Cargo management system and luggage compartment divider pack are optional on all estate models.

* Integrated child seats are only available on standard Titan Black upholstery or optional Titan Black leather upholstery.



Interior shown is Passat Estate SE with optional panoramic sunroof, net partition and metallic paint.

Bring the outside in.

Enjoy the sky above like never before thanks to the Passat's optional panoramic sunroof. Creating a well-lit, airy passenger compartment, it lets in three times more light than a conventional sunroof, and in the Passat Estate, an additional panoramic sunroof to the rear provides even more light and space. What better way to enjoy a starry night or sunlit day? Optional on all models.



Interior shown is Passat Estate SE with optional panoramic sunroof, net partition and 'Vienna' leather upholstery.

The intelligent way to drive.

With numerous driving assistants to help share the workload, the Passat provides all the on-board help you could need. Smart, intelligent and capable, this is a car made for sophisticated drivers who delight in innovative technology.



01 Predictive Pedestrian Protection, part of the optional Driver's Assistance Pack and Driver's Assistance Pack Plus, warns you if it detects, in addition to vehicles, any pedestrians at the edge of the road or on the carriageway via acoustic and optical signals as well as a gentle jolt of the brakes. It even performs an emergency stop should the distance become critical, protecting not only you but also other road users from potential accidents. Optional on SE models and above.

02 Trailer Assist including Park Assist. Anyone who has tried to manoeuvre a vehicle with a trailer attached understands how complicated this can be. The world's first Trailer Assist helps you reverse with a trailer attached, easily, accurately and safely. The optical display visualises actual and possible steering angles in the instrument cluster. Reverse steering is automatic, with direction controlled via the mirror adjustment switch which acts as a joystick, while the driver controls the accelerator and brake and keeps a good look out. Optional on SE models and above. Only in conjunction with the optional swivelling towbar.

03 Traffic Jam Assist takes the stress out of driving in congested traffic by maintaining a constant distance from the vehicle in front preventing you from having to continually stop and start in slow moving traffic. The camera and radar sensor controlled system accelerates, brakes and even steers should the vehicle drift out of its lane, providing the driver maintains hold of the steering wheel. Not only does it help avoid nose-to-tail collisions, it also guides you safely through narrow sections and tight roadwork lanes. Optional on SE models and above in conjunction with DSG gearbox only. Traffic Jam Assist is part of the optional Driver's Assistance Pack Plus. Must be ordered in conjunction with optional LED premium headlights.

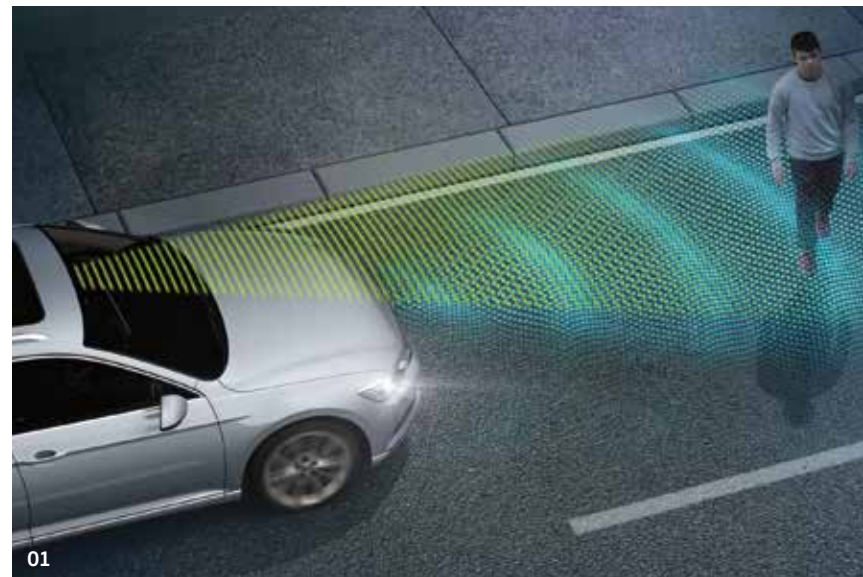

04 Area view. Four cameras located in the boot lid, door mirrors and radiator grille, each with an aperture angle of over 180 degrees, provides a 360-degree view around the Passat helping you manoeuvre safely in any direction. From the display menu, the driver can select the camera views; front, rear, side or bird's-eye view, on either full or split-screen, displayed on the Passat's infotainment system. Optional on SE models and above. Not in conjunction with rear-view camera.

Please refer to your Volkswagen owner's manual for information on system parameters and official guidance on use and operation of all our technology.

Advanced acoustics. State-of-the-art navigation.



01 The **Composition Media system** is equipped with a 6.5 inch colour touch-screen with proximity sensor that recognises in advance your intention to touch the screen and automatically magnifies the display mode. Features also include DAB digital radio receiver, CD player, MDI (Multi Device Interface) via USB connection for compatible products and SD card reader. The media system also includes Bluetooth telephone and audio connection for compatible devices¹, simultaneous pairing of 2 compatible mobile devices, SMS functionality – allowing you to read, compose and send SMS messages using the touch-screen display to a compatible Android smartphone (while the vehicle is stationary), title and compatible cover art display and facilitates music playback from MP3, WMA and AAC files through eight speakers, front and rear with 4 x 20 watt output. Car information display and Think Blue. Trainer. – provide journey analysis and driver tips for more fuel efficient driving. Standard on S, BlueMotion and SE models.



02 The **Discover Navigation touch-screen navigation/radio system with Car-Net 'Guide and Inform'**² builds upon the impressive Composition Media system, but with additional features enabling you to easily manage not only your music, but also navigation data and a broad range of vehicle information. The system offers preloaded European navigation data, 2D/3D map view, three calculated route choices (Fast, Short and Eco), dynamic navigation based on TMC+, branded points of interest and Traffic Sign Display. 3-year's Car-Net 'Guide and Inform' access makes it possible to integrate 'traffic information online' into route guidance and transfer public and personal points of interest to the navigation system. The service also includes information for fuel pricing, parking space availability, weather and news feeds. Standard on SE Business models and above. Optional on S, BlueMotion and SE models.

¹ Devices must be Bluetooth HFP (Hands Free Profile) compatible, please contact your authorised Volkswagen retailer for specific device compatibility.

² Car-Net 'Guide and Inform' services are accessed via a compatible mobile device. Please see www.volkswagen.co.uk for more information. The use of 'Guide and Inform' services entails exchanging large volumes of data. As such, we strongly recommend that you sign-up for a flat rate data plan with your mobile network provider. After the initial 3-year Car-Net contract, an annual subscription is chargeable for the continuation of Car-Net 'Guide and Inform' services.

03 The **Discover Navigation Pro touch-screen navigation/DVD radio system with integrated voice activation, Car-Net 'Guide and Inform Plus'**² and **Car-Net 'App-Connect'** can be operated intuitively via the 8.0 inch TFT colour touch-screen, enabling you to manage music and navigation data. Eight powerful speakers deliver exceptional power and the DVD system is compatible with MP3 and WMA files. It also offers a 64 GB SSD hard drive, two SD card readers, photo display from JPEG and PNG files, voice control and a USB connection. The Discover Navigation Pro also features 'Guide and Inform Plus' providing online access to a range of useful information such as traffic, fuel pricing, parking space availability, weather, news feeds and Google Earth. In addition, the Car-Net 'App-Connect' combines the functionality of Apple 'CarPlay', Google 'Android Auto' and 'MirrorLink'TM allowing 'mirroring' of smartphone display on the infotainment touch-screen via USB connection. Display and operation of certified apps including audio and voice control (if supported by the app). Usage of certified apps only while driving. Only available with compatible smartphones including iPhone 5 and 6. Please see www.volkswagen.co.uk to check smartphone compatibility. Optional on all models.



Concert hall acoustics. Living room luxury.



01

01 The **multifunction leather steering wheel with multifunction display** enables you to operate the radio and phone without taking your hands off the wheel, and GT, Alltrack and R-Line models equipped with automatic DSG transmission, feature paddle shift for ease of operation. A heated steering wheel is optionally available on SE*, SE Business*, GT and Alltrack models. On warm days, **climate control – 3Zone electronic air conditioning** with automatic air recirculation ensures a pleasant interior temperature to suit the individual preference of driver, front and rear seat passengers. Optional on SE and SE Business models. Standard on GT models and above.

02 The **'Dynaudio Confidence'** sound system provides concert hall acoustics via a ten channel digital amplifier, delivering 700 watts output through ten speakers optimally located around the cabin to ensure unique sound quality for every occupant. Optional on SE models and above.

* Must be ordered in conjunction with Winter pack or leather upholstery.



02

Interior shown is Passat GT with optional 'Dynaudio Confidence' soundpack and metallic paint.



Interior shown is Passat GT with optional Discover Navigation Pro touch-screen navigation/DVD radio system with integrated voice activation, Car-Net 'Guide and Inform-Plus' and Car-Net 'App-Connect'.

Car-Net. The smart way to stay connected.



02 Whether you are using a phone, radio or radio/navigation system, **Voice activation** allows you to control everything by spoken command. Available commands are shown on the screen, and your chosen text is highlighted in red. After activation, a red symbol indicates that the instruction has been accepted. Optional on all models. Voice activation is standard on Discover Navigation Pro touch-screen navigation/DVD radio systems.



03 The optional **Car-Net 'App-Connect'** combines functionality of Apple 'CarPlay', Google 'Android Auto' and 'MirrorLink™' allowing 'mirroring' of smartphone display on the infotainment touch-screen via USB connection. Only available with compatible smartphones including iPhone 5 and 6. **Volkswagen apps** such as 'Think Blue. Trainer', 'Shared Audio', 'Drive & Track' or 'My Guide' can help to make your journey more pleasant and interesting, providing useful tips about handling your car, parking opportunities and even where to find the closest café. Volkswagen Apps are only available with compatible smartphones. Please consult www.volkswagen.co.uk to check smartphone compatibility. Optional on all models. Car-Net 'App-Connect' is included with the optional Discover Navigation Pro touch-screen navigation/DVD radio system.

1 Car-Net 'Guide and Inform' services are accessed via a compatible mobile device. Please see www.volkswagen.co.uk for more information. The use of 'Guide and Inform' services entails exchanging large volumes of data. As such, we strongly recommend that you sign-up for a flat rate data plan with your mobile network provider. After the initial 3-year Car-Net contract, an annual subscription is chargeable for the continuation of 'Guide and Inform' services.

01 With Car-Net 'Guide and Inform' ¹ your Passat becomes a mobile network using your smartphone's WIFI hotspot. You can access up-to-the-minute information directly from the internet, enabling you to benefit from continually updated information while you travel, such as online traffic information, fuel pricing, parking space availability, weather and news feeds. Car-Net 'Guide and Inform' includes online navigation software updates, enabling you to download the latest map data. 3-year's Car-Net 'Guide and Inform' access is standard on SE Business models and above, and included with optional navigation systems for S, BlueMotion and SE models. Please contact your authorised Volkswagen retailer for full details.

Opting for the Discover Navigation Pro touch-screen navigation/DVD radio system means that you can benefit from even more features such as Google Earth and more with 'Guide and Inform Plus'. Optional on all models.

Business or personal, practical or sporty, the choice is yours.

Versatile and adaptable, the Passat and Passat Estate has room for your passengers, luggage and more. Depending on your requirements, seven models are available: the S, BlueMotion, SE, SE Business, GT, Alltrack and R-Line, each offering varying levels of trim, ranging from practical and elegant to luxurious and sporty. Whichever you select, you'll benefit from a host of advanced features and refinements.



Model shown is Passat SE Business with optional LED premium headlights and metallic paint.

Passat and Passat Estate S.

The Passat S models are equipped with a whole range of innovative assistance systems fitted as standard, helping to ensure the highest levels of safety, practicality and convenience. Inside, the luxurious interior is fitted with stylish 'Hampshire' cloth upholstery, front seats with lumbar adjustment, a leather trimmed three-spoke multifunction steering wheel and gear knob, and 'Brushed chrome' decorative inserts in the dash, centre console and door panels. Chrome-plated instrument and air vent surrounds, interior lighting with a delay and dimming function create a pleasant ambience, while the 60:40 split folding rear seat backrests (40:20:40 on estate models) offer greater flexibility when carrying luggage or loads, especially in the Passat Estate. Image shown features optional multifunction colour display.



01



02



03



04

01 Automatic Post-Collision Braking System starts the brake operation after impact, and brakes for as long as necessary to reduce the speed of the vehicle to prevent or minimise further collisions.

02 Press and drive (Keyless start) enables you to start the engine using a button in the centre console, without taking the key from your pocket.

03 16 inch 'Aragon' alloy wheels with 215/60 R16 low rolling resistance tyres add a touch of refinement to the exterior of the Passat S.

04 The Composition Media system with 6.5 inch colour touch-screen display, DAB digital radio, Bluetooth telephone and audio connection¹, MDI (Multi Device Interface), SD card reader, single CD player and 'Think Blue. Trainer' with driver tips and journey analysis.

¹ Devices must be Bluetooth HFP (Hands Free Profile) compatible, please contact your authorised Volkswagen retailer for specific phone compatibility.



Model shown is Passat S with optional metallic paint.

The new Passat BlueMotion.



Model shown is new Passat BlueMotion with optional metallic paint.

The Passat Saloon and Estate BlueMotion models are equipped with lowered sports suspension, lowering the body by approximately 15mm. Along with the restyled radiator grille, air resistance is greatly reduced, significantly improving fuel consumption and roadholding. Also contributing to the improved aerodynamics is the innovative lightweight construction and refined gearbox transmission with longer gear ratios.

Add to this such features as low rolling resistance tyres, the Start/Stop function that saves fuel when the vehicle is stationary, battery regeneration (recuperation – energy recovery during braking), visual gear change recommendation for optimum fuel consumption and the latest engine technology, and the new Passat Saloon and Estate BlueMotion become two of the most environmentally-friendly models in the Volkswagen range.

Thanks to the highly efficient 1.6 litre 120 PS TDI SCR diesel engine, the BlueMotion Passat returns an incredible 76.3mpg on the Combined Cycle with low CO₂ emissions of just 95g/km. Performance is not compromised either, with the Saloon model accelerating from 0-62mph in just 10.8 seconds on its way to a top speed of 130mph where the law permits, while Estate models boast a respectable 0-62mph in 11.0 seconds and a top speed of 129mph where the law permits. The unique 'BlueMotion' badging on the front, back and sides is testament to the Passat BlueMotion's outstanding efficiency.

As well as impressive environmental credentials, the new Passat Saloon and Estate BlueMotion offer exceptional comfort and refinement. Featuring 17 inch 'Soho' alloy wheels, uniquely shaped BlueMotion front and rear bumpers, a chrome trimmed front air intake and radiator grille with blue stripe, lowered sports suspension and distinctive 'BlueMotion' badging, creating an exterior that is aerodynamic, sporty and exciting.

01 The **Composition Media system** with 6.5 inch colour touch-screen display, DAB digital radio, Bluetooth telephone and audio connection¹, MDI (Multi Device Interface), SD card reader, SMS functionality – read, compose and send SMS messages using touch-screen display (compatible Android smartphones only) and 'Think Blue. Trainer' with driver tips and journey analysis.

02 17 inch '**Soho**' alloy wheels with 215/60 R17 tyres add style and charisma to the exterior of the Passat BlueMotion.

¹ Devices must be Bluetooth HFP (Hands Free Profile) compatible, please contact your authorised Volkswagen retailer for specific phone compatibility.



01



02



Model shown is new Passat BlueMotion with optional 17" 'Istanbul' alloy wheels, LED premium headlights, Convenience pack and metallic paint.



Interior shown is Passat SE Business with optional Discover Navigation Pro touch-screen navigation/DVD radio system with integrated voice activation, Car-Net 'Guide and Inform Plus' and Car-Net 'App-Connect', multifunction colour display, climate control - 3Zone electronic air conditioning, 'Vienna' leather upholstery and metallic paint.

Passat and Passat Estate SE and SE Business.

The well-appointed Passat SE models build on the S level specification with impressive levels of comfort and luxury and many advanced features. The refined interior is beautifully equipped with 'Kensington' cloth upholstery, an ergoComfort driver's seat with electric backrest and seat cushion tilt adjustment and front passenger's seat with height and lumbar adjustment. Front and rear carpet mats, 'Diamond Silver' decorative inserts in the dash, centre console and door panels, and LED entrance/warning lights in the front doors add further elegance and luxury, while two covered cup holders in the front and a load-through provision in the saloon's rear seat bench provide practical extra touches. The latest version of the driver profile selection takes the Passats to a new level of comfort and relaxation. This driver assistance system brings together numerous settings, allowing you to set the perfect and optimal position, and personalise settings for items such as wing mirrors, map and route settings, radio stations, air conditioning, central locking, windows and interior lighting.

Building upon the impressive Passat SE, the Passat SE Business models are equipped with an even higher level of specification, providing such features as front fog lights, heat insulating rear tinted glass, remote electrically foldable door mirrors and the Discover Navigation system with 3 years Car-Net 'Guide and Inform' internet access providing a range of information, including traffic, fuel pricing, parking space availability, weather and news feeds.



01 The Discover Navigation touch-screen navigation/radio system with Car-Net 'Guide and Inform'¹ offers preloaded European navigation data, 2D/3D map view, three calculated route choices (Fast, Short and Eco), dynamic navigation based on TMC+, branded points of interest and Traffic Sign Display. 3-year's Car-Net 'Guide and Inform' access makes it possible to integrate 'traffic information online' into route guidance and transfer public and personal points of interest to the navigation system. The service also includes information for fuel pricing, parking space availability, weather and news feeds. Standard on SE Business models.



02 Adaptive Cruise Control (ACC), including Front Assist radar sensor controlled distance monitoring system, City emergency braking system, cruise control and speed limiter offers you intelligent control of your driving speed by automatically adjusting acceleration and braking. Whether around town or on the motorway, the system will adjust your speed to that of the vehicle in front, keep your specified distance, warn if you are approaching too fast and, in an emergency situation, generate enough braking force to reduce the severity of a collision or even prevent the collision entirely. Standard on SE and SE Business models.



03 17 inch 'London' alloy wheels with 215/55 R17 self-sealing tyres add a further touch of elegance and safety. Standard on SE and SE Business models.

04 Heat insulating rear tinted glass from the B pillar backwards is 65% light absorbing, reducing exposure to the sun's rays and creating an executive presence. Standard on SE Business models.

¹ Car-Net 'Guide and Inform' services are accessed via a compatible mobile device. Please see www.volkswagen.co.uk for more information. The use of 'Guide and Inform' services entails exchanging large volumes of data. As such, we strongly recommend that you sign-up for a flat rate data plan with your mobile network provider. After the initial 3-year Car-Net contract, an annual subscription is chargeable for the continuation of Car-Net 'Guide and Inform' services.



Interior shown is Passat GT with optional Discover Navigation Pro touch-screen navigation/DVD radio system with integrated voice activation, Car-Net 'Guide and Inform Plus' and Car-Net 'App-Connect', smoking pack and metallic paint.

Passat and Passat Estate GT.



01



02



03



04

The Passat and Passat Estate GT models exude exclusivity, providing the ultimate in attention to detail and craftsmanship. Inside, luxurious seats feature Alcantara seat centre section and 'Vienna' leather* side bolsters, while brushed aluminium decorative inserts in the dash and door panels, 'Piano Black' decorative inserts in the centre console and ambient lighting create elegance and style. Other luxurious features include climate control - 3Zone electronic air conditioning with automatic air recirculation, Discover Navigation system with 3 years' access to Car-Net 'Guide and Inform', remote electrically foldable door mirrors and door mirror puddle lights, and heated windscreen washer jets.

01 Front fog lights with static cornering function and chrome trimmed surround aid vision in poor weather, while enhancing the front design, and rear lights incorporating LED technology with dynamic lighting effect give a distinctive look to the rear.

02 18 inch 'Oxford Anthracite' alloy wheels with 235/45 R18 self-sealing tyres are eye-catching and sporty.

03 Heated front seats add luxury and comfort in the cold weather, giving the interior an especially warm and welcome feel in winter.

04 The Passat GT 2.0 litre BiTDI 240 PS 4MOTION features a number of refinements, including Dynamic Chassis Control (DCC) providing a choice of Sport, Comfort and Normal settings. LED premium headlights with projection technology look sensational and include signature dual 'U-shaped' LED daytime running lights, 12 separate LEDs performing the indicator function, dynamic curve lighting and headlight washers to keep them clean. Stylish trapezoid exhaust tailpipes complete the look.

* Some parts of leather interior will contain artificial leather.

The new Passat Alltrack.

The new Passat Alltrack is designed to take you off the beaten track. Exceptional off-road performance provides all-terrain capability, from smooth and steep to rough and rugged, allowing every day to become an adventure. Its 4MOTION four wheel drive combines with off-road suspension providing up to 27.5mm increased ground clearance and an 'Off-road' setting with hill descent assist to deliver truly outstanding off-road driving characteristics.

Externally, the 'Alltrack' styling pack is designed to impress with uniquely shaped off-road front and rear bumpers, a chrome trimmed radiator grille and front air intake, matt-chrome effect door mirrors, trapezoid exhaust tailpipes and unique 'Alltrack' badging. Meanwhile, prominent anthracite wheel arch protection, matt-chrome effect and anthracite side sill protection, matt-chrome effect underbody protection at the front and rear and sporty 18 inch 'Kalamata' alloys wheels ensure this is a car that's built for action.

Front fog lights with static cornering, heat insulating rear tinted glass, silver anodised roof rails and rear lights with LED technology complete the look, delivering the ultimate in off-road style.

A wealth of interior refinements ensures you travel in comfort and style, whatever the terrain. Reflecting the new Passat Alltrack's off-road character are such details as stylish 'Summit' cloth upholstery, 'Tracks' decorative inserts in the dash, centre console and door panels, brushed stainless steel pedals and door sill protectors with the unique 'Alltrack' logo.

3Zone electronic climate control with automatic air recirculation enables you and your passengers to choose their preferred interior temperature, while ambient lighting, heated windscreen washer jets, remote electrically foldable door mirrors and door mirror puddle lights, provide the highest levels of interior luxury. Quite literally, it's the full package and more.



01 18 inch 'Kalamata' alloy wheels, anthracite wheel arch protection and raised off-road suspension providing up to 27.5mm increased ground clearance ensures exceptional off-road driving capability.



02 The interior of the Alltrack is upholstered in robust 'Summit' upholstery in Titan Black featuring the 'Alltrack' logo in the centre section.



Model shown is new Passat Alltrack with optional 19" 'Albertville' alloy wheels, panoramic sunroof, LED headlights and premium signature paint.

Passat and Passat Estate R-Line.

Sporty, stylish and dynamic, the Passat R-Line models have an equally impressive specification with enhanced body styling and a number of additional features, delivering even greater levels of functionality, comfort and performance. The exterior of the R-Line is unmistakable with its distinctive 'R-Line' styling pack consisting of front and rear bumpers, radiator grille and side skirts. Front fog lights with static cornering function and chrome decorative trim and 18 inch 'Monterrey' alloy wheels complete the elegant, agile look. For those seeking the ultimate R-Line experience, the Passat R-Line 2.0 litre BiTDI 240 PS 4MOTION provides stunning performance along with a number of additional refinements, including Dynamic Chassis Control (DCC) providing a choice of Sport, Comfort and Normal settings, LED premium headlights with projection technology, dual 'U-shaped' LED daytime running lights, 12 separate LEDs which perform the indicator function, dynamic curve lighting and headlight washers, and XDS electronic differential lock for improved traction and handling.

Elegant and eye-catching, the Passat R-Line is designed to get your pulse racing. The driver's ergoComfort seat and passenger's front seat feature 'Race' seat centre section and 'Vienna' leather* side bolsters, creating a luxurious and inviting interior, with the distinctive 'R-Line' logo embossed on the front head restraints, echoing the 'R-Line' logo displayed on the leather trimmed three-spoke multifunction steering wheel with aluminium inserts, stainless steel pedals and matching unique 'R-Line' carpet mats, decorative inserts and door sill protectors.



Interior shown is Passat R-Line 2.0 BiTDI 240 PS 4MOTION with optional Discover Navigation Pro touch-screen navigation/DVD radio system with integrated voice activation, Car-Net 'Guide and Inform Plus' and Car-Net 'App-Connect' and Pure White non-metallic paint.



01 The R-Line interior package includes an ergoComfort seat for the driver with 'Race' seat centre sections and 'Vienna' leather* side bolsters, available in Titan Black/Titan Black. The unique 'R-Line' logo on head restraints completes the sporty look.



02 18 inch 'Monterrey' alloy wheels with 235/45 R18 self-sealing tyres give the exterior of the R-Line its powerful stance.

* Some parts of leather interior will contain artificial leather.



Model shown is Passat Estate R-Line 2.0 BiTDI 240 PS 4MOTION with optional 19" 'Verona' alloy wheels and Pure White non-metallic paint.



01

Alloy wheels.

Stylish alloy wheels contribute to the charismatic road presence of the Passat and Passat Estate, with a choice of elegant or sporty designs adding a touch of individuality.



02



03



04



05



06



07



08



09



10



11



12

01 'Aragon' 6½J x 16 alloy wheels with 215/60 R16 low rolling resistance tyres and anti-theft wheel bolts. Standard on S models.

02 'Soho' 7J x 17 alloy wheels with 215/55 R17 tyres and anti-theft wheel bolts. Standard on BlueMotion models. Optional on SE and SE Business models.

03 'London' 7J x 17 alloy wheels with 215/55 R17 self-sealing tyres and anti-theft wheel bolts. Standard on SE and SE Business models.

04 'Oxford Anthracite' 8J x 18 alloy wheels with 235/45 R18 self-sealing tyres and anti-theft wheel bolts. Standard on GT and optional on SE and SE Business models.

05 'Kalamata' 7J x 18 alloy wheels with 245/45 R18 self-sealing tyres and anti-theft wheel bolts. Standard on Alltrack models.

06 'Monterrey' 8J x 18 alloy wheels with 235/45 R18 self-sealing tyres and anti-theft wheel bolts. Standard on R-Line models.

07 'Istanbul' 7J x 17 alloy wheels with 215/55 R17 tyres and anti-theft wheel bolts. Optional on BlueMotion models.

08 'Sepang' 6½J x 16 alloy wheels with 215/60 R16 tyres and anti-theft wheel bolts. No cost option on SE and SE Business models.

09 'Nivelles Anthracite' 7J x 17 alloy wheels with 215/55 R17 tyres and anti-theft wheel bolts. Optional on SE and SE Business models.

10 'Marseille Anthracite' 8J x 18 alloy wheels with 235/45 R18 tyres and anti-theft wheel bolts. Optional on SE, SE Business and GT models.

11 'Verona' 8J x 19 alloy wheels with 235/40 R19 tyres and anti-theft wheel bolts. Optional on GT and R-Line models.

12 'Albertville' 8J x 19 alloy wheels with 245/40 R19 tyres and anti-theft wheel bolts. Optional on Alltrack models.

Think Blue.

Sustainability + Ingenuity.

'Think Blue' is Volkswagen's promise to create progressive, environmentally friendly products and processes. So, from our concepts to our designs, from our fabrics to our machines, from our buildings to our water supply and from our engines to the open road, we can help shape a more sustainable future. We have already started by creating electric vehicles, BlueMotion models and efficient BlueMotion Technologies that save you money and reduce emissions.

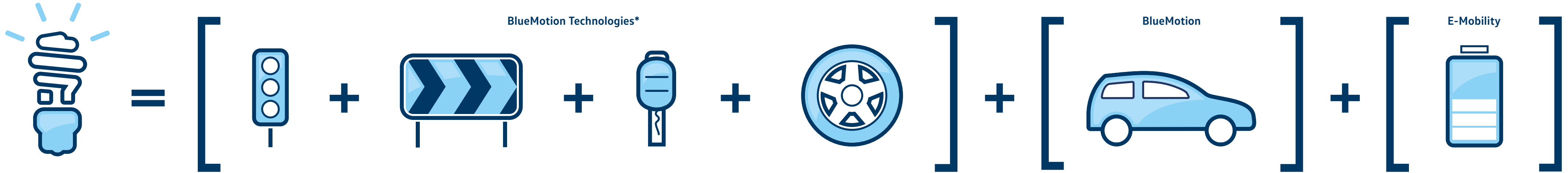

Think Blue.
Smart ideas for sustainable driving.

Start/Stop technology
saves fuel and therefore cuts emissions by automatically switching off the engine when the car isn't in motion.

Brake energy recuperation system
saves fuel by making the most of energy that's usually lost when you brake.

Turbocharged engines
deliver more power when you need it and use less fuel when you don't.

Low rolling resistance tyres
save you fuel by reducing the friction between the tyre and the road, meaning it takes less energy – and less fuel – to go further.

Purpose-built BlueMotion cars
include the full range of BlueMotion Technologies as well as an aerodynamically optimised design to reduce wind resistance and increase efficiency.

Electric vehicles
comprise both hybrid and fully electric vehicles, offering all the features of their regular counterparts combined with the ultimate in driving efficiency and low operating costs. The ultimate way to Think Blue.

*BlueMotion Technologies are available on all Volkswagens, excluding Phaeton, and vary between models.

Paints.

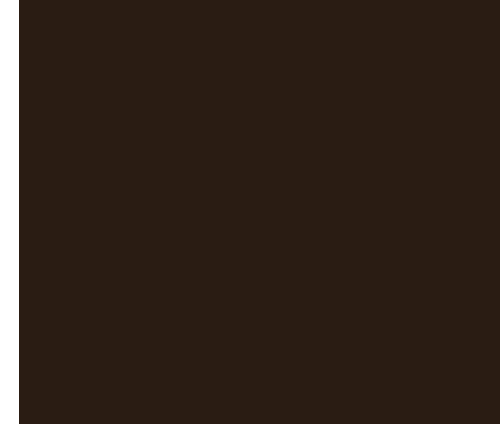
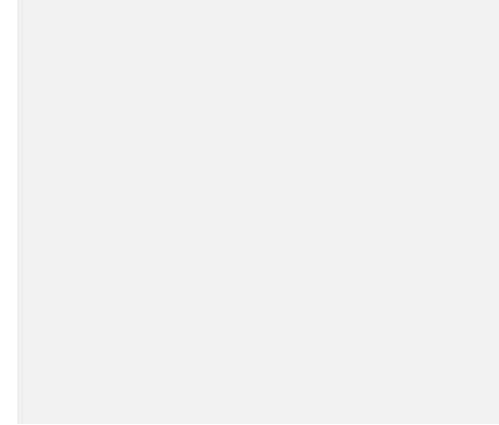
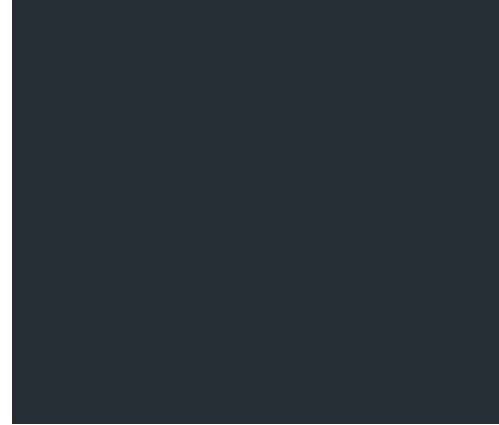
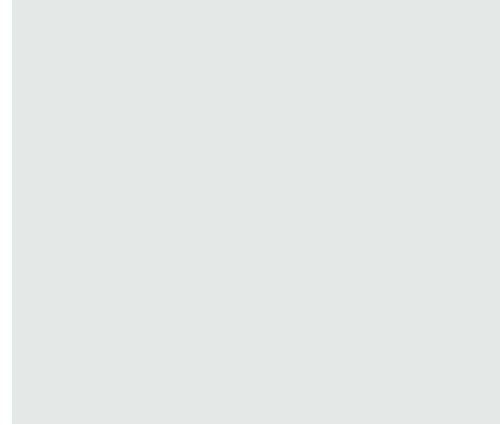

Pure White Non-Metallic OQ

S BM SE SEB GT A RL

Urano Grey Non-Metallic 5K

S BM SE SEB GT A RL

Harvard Blue Metallic 4P

S BM SE SEB GT A RL

Sand Gold Metallic 4T

S BM SE SEB GT A RL

Reflex Silver Metallic 8E

S BM SE SEB GT A RL

Fortana Red Metallic I9

A

Tungsten Silver Metallic K5

S BM SE SEB GT A RL

Dark Oak Brown Metallic P0

S BM SE SEB GT A RL

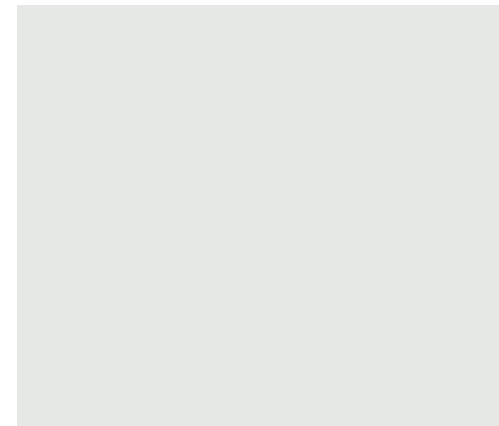
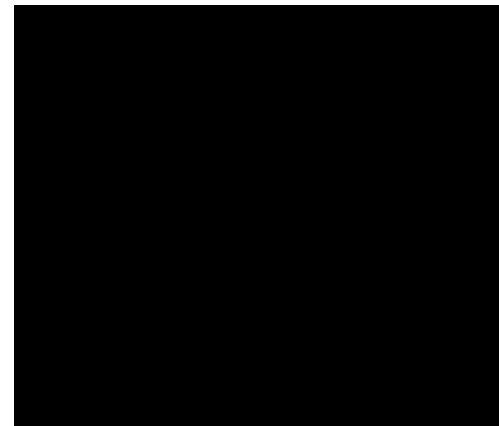

Indium Grey Metallic X3

S BM SE SEB GT A RL

Night Blue Metallic Z2

S BM SE SEB GT A RL

Deep Black Pearl Effect 2T

S BM SE SEB GT A RL

Crimson Red Metallic Signature 5P

S BM SE SEB GT A RL

Oryx White Premium Signature OR

S BM SE SEB GT A RL

Habanero Orange Premium Signature V9

A

Standard Optional at extra cost

S – S BM – BlueMotion SE – SE SEB – SE Business GT – GT A – Alltrack RL – R-Line

Please note: the print processes do not allow exact reproduction of the paint colours.

Upholstery.



'Hampshire' Cloth Titan Black TO

S BM

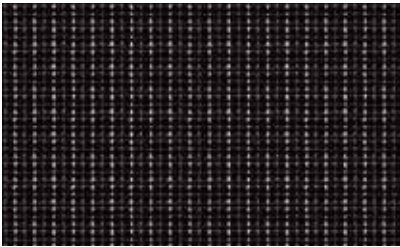

'Kensington' Cloth Titan Black TO

SE SEB



'Kensington' Cloth Espresso TQ

SE SEB



'Kensington' Cloth St Tropez TS

SE SEB



Alcantara/'Vienna' Leather* Titan Black/Titan Black TO

GT



Alcantara/'Vienna' Leather* St Tropez/St Tropez TS

GT



'Summit' Cloth Titan Black TO

A



Alcantara/'Vienna' Leather* Moonrock/Black TT

GT



'Race' Cloth/'Vienna' Leather* Titan Black/Titan Black IN

RL



'Vienna' Leather* Titan Black TO

SE SEB A

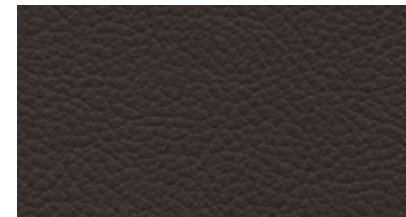

'Vienna' Leather* Espresso TQ

SE SEB



'Vienna' Leather* St Tropez TS

SE SEB



'Nappa' Leather* Titan Black TO

GT

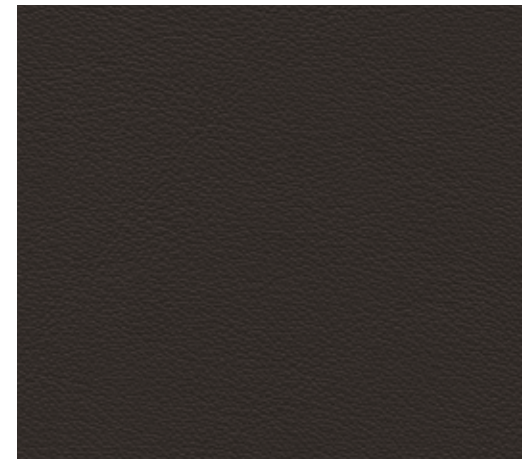

'Nappa' Leather* Espresso TQ

GT

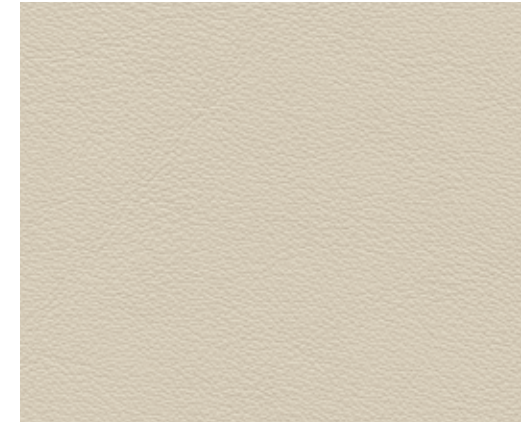

'Nappa' Leather* St Tropez TS

GT



'Nappa' Leather* Marrakesh LW

GT

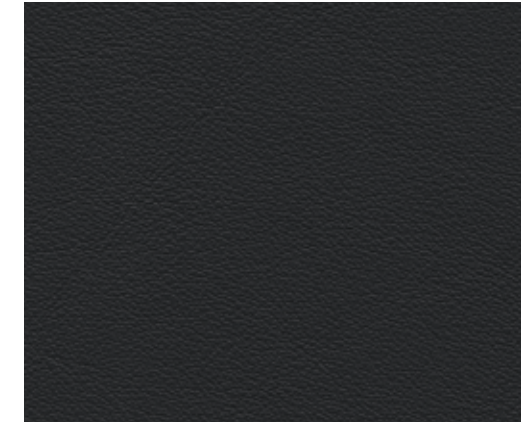

'Nappa' Leather* Titan Black OH

RL



'Nappa' Leather* Flint Grey/Titanium Black OK

RL

Standard
 Optional at extra cost
 S – S BM – BlueMotion SE – SE SEB – SE Business GT – GT A – Alltrack RL – R-Line

Please note: the print processes do not allow exact reproduction of the upholstery colours. * Some parts of leather interior will contain artificial leather.

Combinations.

Seat upholstery – Standard	Dashboard	Carpet	Rooflining	Pure White Non-Metallic* 0Q	Urano Grey Non-Metallic 5K	Harvard Blue Metallic* 4P	Sand Gold Metallic* 4T	Reflex Silver Metallic* 8E	Fortana Red Metallic* 19	Tungsten Silver Metallic* K5	Dark Oak Brown Metallic* P0	Indium Grey Metallic* X3	Night Blue Metallic* Z2	Deep Black Pearl Effect* 2T	Crimson Red Metallic Signature* 5P	Oryx White Premium Signature* 0R	Habanero Orange Premium Signature* V9
'Hampshire' cloth Standard on S and BlueMotion Titan Black (TO)	Black	Black	St Tropez	●	●	●	●	●	-	●	●	●	●	●	●	●	-
'Kensington' cloth Standard on SE and SE Business Titan Black (TO)	Black	Black	St Tropez	●	●	●	●	●	-	●	●	●	●	●	●	●	-
Espresso (TQ)	Espresso	Espresso	St Tropez	●	●	●	●	●	-	●	●	●	●	●	-	●	-
St Tropez (TS)	Black/St Tropez	Black	St Tropez	●	●	●	●	●	-	●	●	●	●	●	●	●	-
Alcantara seat centre section and 'Vienna' leather† side bolsters Standard on GT Titan Black/Titan Black (TO)	Black	Black	St Tropez	●	●	●	●	●	-	●	●	●	●	●	●	●	-
Espresso/Espresso (TQ)	Espresso	Espresso	St Tropez	●	●	●	●	●	-	●	●	●	●	●	-	●	-
St Tropez/St Tropez (TS)	Black/St Tropez	Black	St Tropez	●	●	●	●	●	-	●	●	●	●	●	●	●	-
Moonrock/Black (TT)	Black	Black	St Tropez	●	●	●	-	●	-	●	●	●	●	●	●	●	-
'Summit' cloth Standard on Alltrack Titan Black (TO)	Black	Black	St Tropez, Black*	●	●	●	●	●	●	●	●	●	●	●	●	●	●
'Race' seat centre section and 'Vienna' leather† side bolsters Standard on R-Line Titan Black/Titan Black (IN)	Black	Black	Black	●	●	●	-	●	-	●	-	●	●	●	●	●	-

● Standard. - Not available.

* Pure White non-metallic, metallic, pearl effect, metallic signature, premium signature paints and black rooflining are optional at extra cost.

† Some parts of leather interior will contain artificial leather.

Image shown features standard 'Kensington' cloth in Titan Black.

Combinations.

Seat upholstery – Optional	Dashboard	Carpet	Rooflining	Pure White Non-Metallic* 0Q	Urano Grey Non-Metallic 5K	Harvard Blue Metallic* 4P	Sand Gold Metallic* 4T	Reflex Silver Metallic* 8E	Fortana Red Metallic* 19	Tungsten Silver Metallic* K5	Dark Oak Brown Metallic* P0	Indium Grey Metallic* X3	Night Blue Metallic* Z2	Deep Black Pearl Effect* 2T	Crimson Red Metallic Signature* 5P	Oryx White Premium Signature* OR	Habanero Orange Premium Signature* V9	
'Vienna' leather*† Optional SE and SE Business																		
Titan Black (TO)	Black	Black	St Tropez	○	○	○	○	○	-	○	○	○	○	○	○	○	-	
Espresso (TQ)	Espresso	Espresso	St Tropez	○	○	○	○	○	-	○	○	○	○	○	-	○	-	
St Tropez (TS)	Black/St Tropez	Black	St Tropez	○	○	○	○	○	-	○	○	○	○	○	○	○	-	
'Vienna' leather*† Optional Alltrack																		
Titan Black (TO)	Black	Black	St Tropez, Black*	○	○	○	○	○	○	○	○	○	○	○	○	○	○	
Espresso (TQ)	Espresso	Espresso	St Tropez	○	○	○	○	○	○	○	○	○	○	○	-	○	○	
St Tropez (TS)	Black/St Tropez	Black	St Tropez	○	○	○	○	○	○	○	○	○	○	○	○	○	○	
'Nappa' leather*† Optional on GT																		
Titan Black (TO)	Black	Black	St Tropez	○	○	○	○	○	-	○	○	○	○	○	○	○	-	
Espresso (TQ)	Espresso	Espresso	St Tropez	○	○	○	○	○	-	○	○	○	○	○	-	○	-	
St Tropez (TS)	Black/St Tropez	Black	St Tropez	○	○	○	○	○	-	○	○	○	○	○	○	○	-	
Marrakesh (LW)	Black	Black	St Tropez	○	○	○	○	○	-	○	○	○	○	○	-	○	-	
'Nappa' leather*† Optional on R-Line																		
Titan Black (OH)	Black	Black	Black	○	○	-	-	-	-	○	-	-	-	○	-	-	-	
Flint Grey/Titanium Black (OK)	Black	Black	Black	○	○	-	-	-	-	○	-	-	-	○	-	-	-	
'Nappa' leather*† featuring climate front seats with electric 12-way adjustment and driver's massage and memory function Optional on GT																		
Titan Black (OH)	Black	Black	St Tropez	○	○	○	○	○	-	○	○	○	○	○	○	○	-	
Espresso (TQ)	Espresso	Espresso	St Tropez	○	○	○	○	○	-	○	○	○	○	○	-	○	-	

○ Optional at extra cost. – Not available.

* Pure White non-metallic, metallic, pearl effect, metallic signature, premium signature paints, leather upholstery, climate front seats and black rooflining are optional at extra cost.

† Some parts of leather interior will contain artificial leather.

Image shown features optional 'Nappa' leather in Titan Black.

There's a Volkswagen for all of us.

Nippy city run around? Luxurious executive saloon? Open-top cruiser? Whatever it is you're looking for, we probably have it. From the iconic Beetle and Golf GTI to the up! and fuel-efficient BlueMotion Golf, there's a Volkswagen for everyone.

If you're thinking you might like to try a different Volkswagen, take a look at the selection below to see what else we have. There are 21 models in our range, so there's bound to be at least one that catches your eye.

To see these models and configure your ideal Volkswagen, visit: www.volkswagen.co.uk



Sporty

Golf: As exciting to drive as it is to look at. Style, performance and power.

You will also find our sporty gene in the iconic Golf GTD and Golf R.



Efficient

Our **BlueMotion** models benefit from innovative energy-saving technology that helps you optimise fuel consumption and reduce harmful emissions. This includes low rolling resistance tyres and improved aerodynamics, accompanied with advanced engines and gearboxes. Choose from the BlueMotion Polo, Golf, Golf Estate and Golf SV.

However, BlueMotion Technology can be found across our range where automatic Start/Stop technology and brake energy recuperation is standard on the majority of our engines, helping you to save more money by being more efficient.



Spacious family cars

New Sharan: The ultimate in convenience with sliding rear doors, and enough space for the whole family. And their luggage. And the dogs.

If it's space you're after, then you might also like to consider the Tiguan, Golf SV, Golf Estate, Touran and Passat Estate.



Style

Beetle: The original icon. And still the most unique way to make a fashion statement.

For more fun with the top down, why not consider Beetle Cabriolet or the Golf Cabriolet.



City run around

up!: The ideal city car. Efficient, fun and surprisingly spacious, with that trademark Volkswagen solidity.

If you're looking for something slightly more spacious, then why not consider the up!'s bigger sibling, the Polo. City run around efficiency with more versatility and even more space can be found on the iconic Golf.



Executive

Volkswagen CC: Perfectly turned out high-tech, executive luxury. A contemporary, stylish and innovative coupé.

All the luxury you need can also be found in the Jetta, and executive comfort in the Passat and Passat Estate – winner of 'European Car of the Year 2015'.



4x4

Touareg: The SUV just got smarter. True four by four capability off-road, and smooth, luxurious and powerful when on it. Features four wheel drive technology, '4MOTION', as standard for optimum road grip, stability and control.

Go anywhere, do anything in our four wheel drive alternatives: new Golf Alltrack, Tiguan and Passat and Passat Estate 4MOTION models.



Model shown is Passat Estate R-Line 2.0 BiTDI 240 PS 4MOTION with optional 19" 'Verona' alloy wheels and metallic paint.

Built for performance. And economy.

The powerful 2.0 litre BiTDI 240 PS 4MOTION with DSG gearbox produces a massive 500Nm of torque, accelerating the Passat saloon from 0-62mph in just 6.1 seconds and the estate model in a respectable 6.3 seconds. And not only is it fast, it's economical too. Thanks to a lightweight design that's 85kg lighter than the outgoing model, allied with the latest sustainable engine technology, the Passat incurs lower operating and fuel costs than ever before, while sustainable technology reduces CO₂ emissions to new low levels. Designed to benefit your pocket and the environment, the Passat and Passat Estate deliver phenomenal results, whichever engine you select.

Technical specification – Passat Saloon.

	S, SE, SE Business 1.6 ltr TDI 120 PS BMT	BlueMotion 1.6 ltr TDI SCR 120 PS	GT 1.6 ltr TDI 120 PS BMT	S, SE, SE Business 2.0 ltr TDI 150 PS BMT	GT, R-Line 2.0 ltr TDI 150 PS BMT	GT, R-Line 2.0 ltr TDI SCR 190 PS BMT	GT, R-Line 2.0 ltr BiTDI SCR 240 PS BMT 4MOTION
Engine							
Engine type	4 cylinder diesel	4 cylinder diesel	4 cylinder diesel	4 cylinder diesel	4 cylinder diesel	4 cylinder diesel	4 cylinder diesel
Cubic capacity, ltrs/cc	1.6/1598	1.6/1598	1.6/1598	2.0/1968	2.0/1968	2.0/1968	2.0/1968
Max. output, PS ⁽⁰¹⁾ /kW	120/88	120/88	120/88	150/110	150/110	190/140	240/176
at rpm	3600-4000	3600-4000	3600-4000	3500-4000	3500-4000	3500-4000	4000
Max. torque, lbs.ft/Nm	185/250	185/250	185/250	251/340	251/340	295/400	369/500
at rpm	1750-3500	1750-3500	1750-3500	1750-3000	1750-3000	1750-3000	1750-2500
Gearbox	6-spd manual 7-spd auto DSG	6-spd manual -	6-spd manual 7-spd auto DSG	6-spd manual 6-spd auto DSG	6-spd manual 6-spd auto DSG	6-spd manual 6-spd auto DSG	- 7-spd auto DSG

Weights, kgs							
Manual gearbox:							
Unladen weight ⁽⁰²⁾	1444	1474	1444	1475	1475	1505	-
Gross vehicle weight	1990	2020	1990	2020	2020	2080	-
Payload ⁽⁰²⁾	621	621	621	620	620	650	-
Axle load limit: Front	1060	1030	1060	1070	1070	1080	-
Rear	980	1040	980	1000	1000	1050	-
Automatic DSG gearbox:							
Unladen weight ⁽⁰²⁾	1459	-	1459	1501	1501	1549	1721
Gross vehicle weight	2000	-	2000	2040	2040	2110	2260
Payload ⁽⁰²⁾	616	-	616	614	614	636	614
Axle load limit: Front	1070	-	1070	1090	1090	1100	1160
Rear	980	-	980	1000	1000	1060	1150

Trailer load limits, kgs ⁽⁰³⁾							
Braked 12% incline:							
Manual gearbox	1500	1500	1500	2000	2000	2000	-
Automatic DSG gearbox	1500	-	1500	2000	2000	2000	2200
Unbraked:							
Manual gearbox	720	730	720	730	730	750	-
Automatic DSG gearbox	720	-	720	750	750	750	750
Towbar load limit	90	90	90	90	90	90	90
Max. roof load	100	100	100	100	100	100	100

	S, SE, SE Business 1.6 ltr TDI 120 PS BMT	BlueMotion 1.6 ltr TDI SCR 120 PS	GT 1.6 ltr TDI 120 PS BMT	S, SE, SE Business 2.0 ltr TDI 150 PS BMT	GT, R-Line 2.0 ltr TDI 150 PS BMT	GT, R-Line 2.0 ltr TDI SCR 190 PS BMT	GT, R-Line 2.0 ltr BiTDI SCR 240 PS BMT 4MOTION
Performance							
Top speed, mph (km/h), where the law permits							
Manual gearbox	128 (206)	130 (210)	128 (206)	136 (220)	136 (220)	147 (237)	-
Automatic DSG gearbox	128 (206)	-	128 (206)	135 (218)	135 (218)	146 (235)	149 (240)
Acceleration, secs 0 – 62mph							
Manual gearbox	10.8	10.8	10.8	8.7	8.7	7.9	-
Automatic DSG gearbox	10.8	-	10.8	8.7	8.7	7.7	6.1
ABI insurance group, 1 - 50	15E, 12E, 12E	15E	13E	21E, 19E, 19E	19E, 19E	22E, 23E	28E, 28E

Environmental information							
Fuel grade, minimum	Diesel ⁽⁰⁴⁾	Diesel ⁽⁰⁴⁾	Diesel ⁽⁰⁴⁾	Diesel ⁽⁰⁴⁾	Diesel ⁽⁰⁴⁾	Diesel ⁽⁰⁴⁾	Diesel ⁽⁰⁴⁾
Fuel tank capacity, galls/ltrs ⁽⁰⁵⁾	12/59	12/59	12/59	14/66	14/66	14/66	14/66
Official fuel consumption							
manual gearbox,							
mpg/ltr per 100km ⁽⁰⁶⁾							
Urban	60.1/4.7	65.7/4.3	57.6/4.9	60.1/4.7	58.9/4.8	57.6/4.9	-
Extra-urban	78.5/3.6	85.6/3.3	74.3/3.8	78.5/3.6	74.3/3.8	76.3/3.7	-
Combined	70.6/4.0	76.3/3.7	67.3/4.2	70.6/4.0	68.9/4.1	68.9/4.1	-
Official fuel consumption							
automatic DSG gearbox,							
mpg/ltr per 100km ⁽⁰⁶⁾							
Urban	62.8/4.5	-	62.8/4.5	54.3/5.2	53.3/5.3	52.3/5.4	44.1/6.4
Extra-urban	76.3/3.7	-	72.4/3.9	70.6/4.0	68.9/4.1	68.9/4.1	61.4/4.6
Combined	70.6/4.0	-	68.9/4.1	64.2/4.4	62.8/4.5	61.4/4.6	53.3/5.3
Official CO₂ emission, g/km							
Manual gearbox ⁽⁰⁷⁾	105	95	109	106	109	107	-
Automatic DSG gearbox ⁽⁰⁷⁾	103	-	106	116	119	119	139
Emission class	EURO 6	EURO 6	EURO 6	EURO 6	EURO 6	EURO 6	EURO 6
Noise, dB							
Manual gearbox	70.0	72.0	70.0	72.0	72.0	71.0	-
Automatic DSG gearbox	70.0	-	70.0	67.0	67.0	69.0	69.0

BMT refers to BlueMotion Technology. SCR (Selective Catalytic Reduction) requires AdBlue®, please see www.volkswagen.co.uk/technology/adblue for more details.

Technical specification – Passat Estate.

	S, SE, SE Business 1.6 ltr TDI 120 PS BMT	BlueMotion 1.6 ltr TDI SCR 120 PS	GT 1.6 ltr TDI 120 PS BMT	S, SE, SE Business 2.0 ltr TDI 150 PS BMT	GT, R-Line 2.0 ltr TDI 150 PS BMT	GT, R-Line 2.0 ltr TDI SCR 190 PS BMT	GT, R-Line 2.0 ltr BiTDI SCR 240 PS BMT 4MOTION
Engine							
Engine type	4 cylinder diesel	4 cylinder diesel	4 cylinder diesel	4 cylinder diesel	4 cylinder diesel	4 cylinder diesel	4 cylinder diesel
Cubic capacity, ltrs/cc	1.6/1598	1.6/1598	1.6/1598	2.0/1968	2.0/1968	2.0/1968	2.0/1968
Max. output, PS ⁽⁰¹⁾ /kW	120/88	120/88	120/88	150/110	150/110	190/140	240/176
at rpm	3600-4000	3600-4000	3600-4000	3500-4000	3500-4000	3500-4000	4000
Max. torque, lbs.ft/Nm	185/250	185/250	185/250	251/340	251/340	295/400	369/500
at rpm	1750-3500	1750-3500	1750-3500	1750-3000	1750-3000	1750-3000	1750-2500
Gearbox	6-spd manual 7-spd auto DSG	6-spd manual -	6-spd manual 7-spd auto DSG	6-spd manual 6-spd auto DSG	6-spd manual 6-spd auto DSG	6-spd manual 6-spd auto DSG	- 7-spd auto DSG

Weights, kgs							
Manual gearbox:							
Unladen weight ⁽⁰²⁾	1485	1505	1485	1503	1503	1590	-
Gross vehicle weight	2060	2070	2060	2060	2060	2180	-
Payload ⁽⁰²⁾	650	640	650	632	632	665	-
Axle load limit: Front	1040	1020	1040	1050	1050	1080	-
Rear	1070	1100	1070	1070	1070	1150	-
Automatic DSG gearbox:							
Unladen weight ⁽⁰²⁾	1500	-	1500	1541	1541	1581	1735
Gross vehicle weight	2060	-	2060	2130	2130	2170	2310
Payload ⁽⁰²⁾	635	-	635	664	664	664	650
Axle load limit: Front	1050	-	1050	1100	1100	1100	1140
Rear	1060	-	1060	1080	1080	1120	1220

Trailer load limits, kgs ⁽⁰³⁾							
Braked 12% incline:							
Manual gearbox	1500	1500	1500	2000	2000	2000	-
Automatic DSG gearbox	1500	-	1500	2000	2000	2000	2200
Unbraked:							
Manual gearbox	740	750	740	750	750	750	-
Automatic DSG gearbox	750	-	750	750	750	750	750
Towbar load limit	90	90	90	90	90	90	90
Max. roof load	100	100	100	100	100	100	100

	S, SE, SE Business 1.6 ltr TDI 120 PS BMT	BlueMotion 1.6 ltr TDI SCR 120 PS	GT 1.6 ltr TDI 120 PS BMT	S, SE, SE Business 2.0 ltr TDI 150 PS BMT	GT, R-Line 2.0 ltr TDI 150 PS BMT	GT, R-Line 2.0 ltr TDI SCR 190 PS BMT	GT, R-Line 2.0 ltr BiTDI SCR 240 PS BMT 4MOTION
Performance							
Top speed, mph (km/h), where the law permits							
Manual gearbox	127 (204)	129 (208)	127 (204)	135 (218)	135 (218)	146 (235)	-
Automatic DSG gearbox	127 (204)	-	127 (204)	134 (216)	134 (216)	144 (233)	147 (238)
Acceleration, secs 0 – 62mph							
Manual gearbox	11.0	11.0	11.0	8.9	8.9	8.1	-
Automatic DSG gearbox	11.0	-	11.0	8.9	8.9	7.9	6.3
ABI insurance group, 1 - 50	15E, 12E, 12E	15E	13E	21E, 19E, 19E	19E, 19E	22E, 23E	28E, 28E

Environmental information							
Fuel grade, minimum	Diesel ⁽⁰⁴⁾	Diesel ⁽⁰⁴⁾	Diesel ⁽⁰⁴⁾	Diesel ⁽⁰⁴⁾	Diesel ⁽⁰⁴⁾	Diesel ⁽⁰⁴⁾	Diesel ⁽⁰⁴⁾
Fuel tank capacity, galls/ltrs ⁽⁰⁵⁾	12/59	12/59	12/59	14/66	14/66	14/66	14/66
Official fuel consumption							
manual gearbox,							
mpg/ltr per 100km ⁽⁰⁶⁾							
Urban	58.9/4.8	65.7/4.3	57.6/4.9	58.9/4.8	57.6/4.9	56.5/5.0	-
Extra-urban	76.3/3.7	85.6/3.3	74.3/3.8	76.3/3.7	74.3/3.8	74.3/3.8	-
Combined	68.9/4.1	76.3/3.7	67.3/4.2	68.9/4.1	67.3/4.2	67.3/4.2	-
Official fuel consumption							
automatic DSG gearbox,							
mpg/ltr per 100km ⁽⁰⁶⁾							
Urban	62.8/4.5	-	61.4/4.6	53.3/5.3	51.4/5.5	52.3/5.4	43.5/6.5
Extra-urban	76.3/3.7	-	72.4/3.9	68.9/4.1	65.7/4.3	68.9/4.1	60.1/4.7
Combined	70.6/4.0	-	68.9/4.1	62.8/4.5	60.1/4.7	61.4/4.6	52.3/5.4
Official CO₂ emission, g/km							
Manual gearbox ⁽⁰⁷⁾	107	95	110	107	110	110	-
Automatic DSG gearbox ⁽⁰⁷⁾	104	-	107	119	122	120	140
Emission class	EURO 6	EURO 6	EURO 6	EURO 6	EURO 6	EURO 6	EURO 6
Noise, dB							
Manual gearbox	70.0	72.0	70.0	72.0	72.0	71.0	-
Automatic DSG gearbox	70.0	-	70.0	67.0	67.0	69.0	69.0

BMT refers to BlueMotion Technology. SCR (Selective Catalytic Reduction) requires AdBlue®, please see www.volkswagen.co.uk/technology/adblue for more details.

Technical specification – Passat Alltrack.

	Alltrack 2.0 ltr TDI SCR 150 PS BMT 4MOTION	Alltrack 2.0 ltr TDI SCR 190 PS BMT 4MOTION
Engine		
Engine type	4 cylinder diesel	4 cylinder diesel
Cubic capacity, ltrs/cc	2.0/1968	2.0/1968
Max. output, PS ⁽⁰¹⁾ /kW	150/110	190/140
at rpm	3500-4000	3600-4000
Max. torque, lbs.ft/Nm	251/340	295/400
at rpm	1750-3000	1900-3300
Gearbox	6-spd manual	–
	–	6-spd auto DSG

Weights, kgs

Manual gearbox:		
Unladen weight ⁽⁰²⁾	1670	–
Gross vehicle weight	2260	–
Payload ⁽⁰²⁾	665	–
Axle load limit: Front	1100	–
Rear	1210	–

Automatic DSG gearbox:		
Unladen weight ⁽⁰²⁾	–	1705
Gross vehicle weight	–	2290
Payload ⁽⁰²⁾	–	6600
Axle load limit: Front	–	1120
Rear	–	1220

Trailer load limits, kgs ⁽⁰³⁾

Braked 12% incline:		
Manual gearbox	2200	–
Automatic DSG gearbox	–	2200

Unbraked:		
Manual gearbox	750	–
Automatic DSG gearbox	–	750

Towbar load limit	90	90
Max. roof load	100	100

	Alltrack 2.0 ltr TDI SCR 150 PS BMT 4MOTION	Alltrack 2.0 ltr TDI SCR 190 PS BMT 4MOTION
Performance		
Top speed, mph (km/h), where the law permits		
Manual gearbox	127 (205)	–
Automatic DSG gearbox	–	136 (220)
Acceleration, secs 0 – 62mph		
Manual gearbox	9.2	–
Automatic DSG gearbox	–	8.0
ABI insurance group, 1 - 50	TBA	TBA

Environmental information

Fuel grade, minimum	Diesel ⁽⁰⁴⁾	Diesel ⁽⁰⁴⁾
Fuel tank capacity, galls/ltrs ⁽⁰⁵⁾	12/59	12/59

Official fuel consumption

manual gearbox,		
mpg/ltr per 100km ⁽⁰⁶⁾		
Urban	47.9/5.9	–
Extra-urban	65.7/4.3	–
Combined	57.6/4.9	–

Official fuel consumption

automatic DSG gearbox,		
mpg/ltr per 100km ⁽⁰⁶⁾		
Urban	–	46.3/6.1
Extra-urban	–	60.1/4.7
Combined	–	54.3/5.2

Official CO₂ emission, g/km

Manual gearbox ⁽⁰⁷⁾	130	–
Automatic DSG gearbox ⁽⁰⁷⁾	–	137

Emission class	EURO 6	EURO 6
----------------	--------	--------

Noise, dB

Manual gearbox	73.0	–
Automatic DSG gearbox	–	69.0

BMT refers to BlueMotion Technology.
SCR (Selective Catalytic Reduction) requires AdBlue®, please see www.volkswagen.co.uk/technology/adblue for more details.

Technology.

Technical specification notes

- The maximum power output figures are quoted in PS (or Pferdestärke, which is the metric equivalent of horsepower). To convert from metric to imperial horsepower, divide the PS figure by 1.0139.
- Figures are calculated in accordance with manufacturer’s criteria. The individual unladen weight depends on the specification of the vehicle, this then reduces the possible payload accordingly. The unladen weight and payload both include the fuel tank 90% full, driver (68kg) and luggage (7kg) in line with EU directive 95/48.
- With increasing altitude the engine performance diminishes. From 1,000m above sea level and for every 1,000m thereafter 10% of the vehicle/trailer weight (trailer weight + gross vehicle weight) must be deducted.
- The use of 100% RME and FAME (bio diesel) is not possible. Forecourt diesel with up to 7% bio diesel content, adhering to standard BS EN 590, can be used in diesel engines. The use of ethanol in forecourt petrol meeting BS EN 228 is allowable.
- The size of the fuel tank is approximate and therefore it may be possible to add a greater amount of fuel than the size of the tank specified, due to the space in the filler neck.
- Fuel consumption and CO₂ figures are obtained under standardised EU test conditions (Directive 93/116/EEC). This allows a direct comparison between different manufacturer models but may not represent the actual fuel consumption achieved in ‘real world’ driving conditions. More information is available on the Volkswagen web site at www.volkswagen.co.uk and at www.vca.gov.org.
- The weight of a vehicle will influence the level of CO₂ emission it produces; as a result, vehicles with higher levels of specification and factory-fitted options may emit higher levels of CO₂.

Transmission

- Electronic differential lock, combined with a hydraulically operated single-plate dry clutch with asbestos-free lining via a six manual or six and seven speed automatic DSG gearbox
- Front wheel drive through asbestos-free single-plate dry clutch. Hydraulic clutch-mechanism. Six speed manual, six or seven speed automatic DSG gearbox with double joint half axles (wet clutch on six speed DSG models)
- Four wheel drive, 4MOTION: Six speed manual 2.0 litre TDI 150 PS. Six speed automatic DSG 2.0 litre TDI SCR 190 PS. Seven speed automatic DSG 2.0 litre BiTDI SCR 240 PS

Running gear

- ESC (Electronic Stability Control) including EDL (Electronic Differential Lock), ASR (Traction Control), EDTC (Engine Drag Torque Control) and Countersteer Support with trailer stabilisation function
- Front suspension through coil springs with telescopic shock absorbers, all elements integrated in chassis legs
- Rear suspension with gas pressure shock absorbers and separate springs
- Multilink rear axle
- Wheel control: front through chassis legs and (lower) triangular wishbones (directionally stabilising steering roll radius)
- Wheel control: rear through four-link suspension with independent wheel suspension
- Front and rear anti-roll bar
- XDS electronic differential lock (2.0 litre BiTDI SCR 240 PS 4MOTION only)

Steering

- Electro-mechanical steering rack
- Collapsible, height and lengthways adjustable safety steering column

Brakes

- Electronically controlled Anti-lock Braking System (ABS) with Electronic Brake-pressure Distribution (EBD)
- Diagonal twin-circuit brake system with ventilated front disc brakes and rear disc brakes
- Asbestos-free brake pad
- HBA (Hydraulic Brake Assist)

Engines

- Front transverse-installed engine

- 1.6 litre/120 PS ⁽⁰¹⁾ (88 kW) common rail diesel engine: EU6 emissions standard, four cylinder in-line common rail diesel engine, with four valves per cylinder. Fitted with a turbocharger and a DPF (diesel particulate filter). Available with a six speed manual or a seven speed automatic DSG transmission

- 1.6 litre/120 PS ⁽⁰¹⁾ (88 kW) common rail diesel engine: EU6 emissions standard, four cylinder in-line common rail diesel engine, with four valves per cylinder. Fitted with a turbocharger and a DPF (diesel particulate filter) with SCR (Selective Catalytic Reduction). Available with a six speed manual transmission

- 2.0 litre/150 PS ⁽⁰¹⁾ (110 kW) common rail diesel engine: EU6 emissions standard, four cylinder in-line common rail diesel engine, with four valves per cylinder. Fitted with a turbocharger and a DPF (diesel particulate filter). Available with a six speed manual or a six speed automatic DSG transmission

- 2.0 litre/190 PS ⁽⁰¹⁾ (140 kW) common rail diesel engine: EU6 emissions standard, four cylinder in-line common rail diesel engine, with four valves per cylinder. Fitted with a turbocharger and a DPF (diesel particulate filter) with SCR (Selective Catalytic Reduction). Available with a six speed manual or a six speed automatic DSG transmission

- 2.0 litre/240 PS ⁽⁰¹⁾ (176 kW) common rail diesel engine: EU6 emissions standard, four cylinder in-line common rail diesel engine, with four valves per cylinder. Fitted with a turbocharger and a DPF (diesel particulate filter) with SCR (Selective Catalytic Reduction). BiTurbo second turbocharger or supercharger. Available with a seven speed automatic DSG transmission

SCR (Selective Catalytic Reduction) requires AdBlue®, please see www.volkswagen.co.uk/technology/adblue for more details.

Dimensions.

Exterior dimensions	Passat Saloon
Length, mm	4767
Width – including door mirrors, mm	2083
Width – opened front/rear doors, mm	3798/3685
Height – mm	1456
Height – opened bonnet/floor, mm	1782
Height – opened tailgate/floor, mm	1747
Wheelbase, mm	2791
Turning circle, m	11.7

Interior dimensions	Passat Saloon
Effective headroom – front, mm (with sunroof)	1034 (993)
Effective headroom – rear, mm (with sunroof)	964 (964)
Elbow width, front, mm	1506
Elbow width, rear, mm	1506
Legroom front, mm	1045
Legroom rear, mm	973

Maximum luggage capacity, litres VDA measuring method using 200 x 100 x 50mm blocks	Passat Saloon
With rear seats upright	586
With rear seats folded	1152

On illustrations, where arrows and figures are shown inside of the vehicle, the measurements are for interior dimensions. Where arrows and figures are shown outside of the vehicle, the measurements are for exterior dimensions.

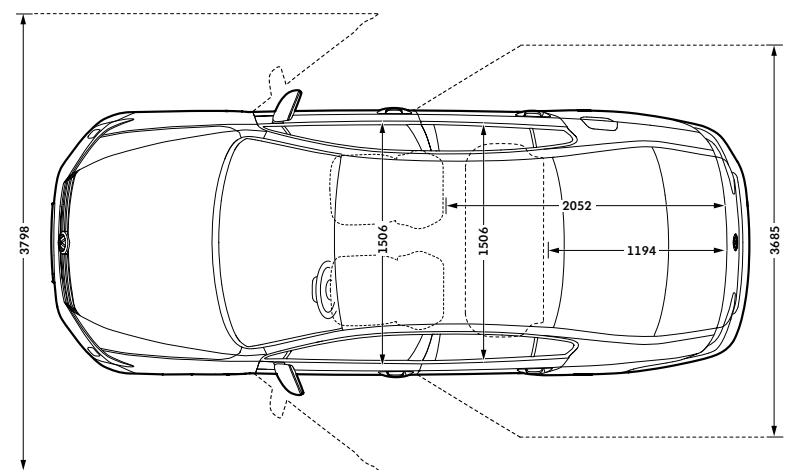
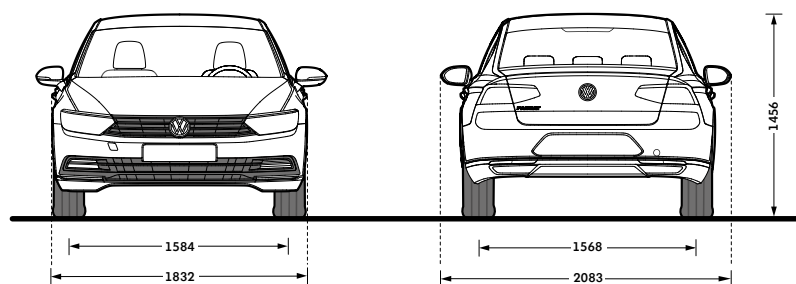
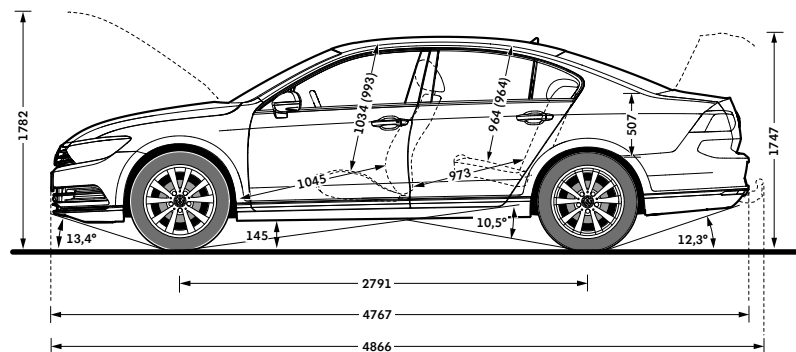

Exterior dimensions	Passat Estate	New Passat Alltrack
Length, mm	4767	4777
Width – including door mirrors, mm	2083	2083
Width – opened front/rear doors, mm	3798/3594	TBA
Height – mm	1477	1506
Height – opened bonnet/floor, mm	1782	TBA
Height – opened tailgate/floor, mm	2047	2076
Wheelbase, mm	2791	2789
Turning circle, m	11.7	11.7

Interior dimensions	Passat Estate	New Passat Alltrack
Effective headroom – front, mm (with sunroof)	985 (949)	1031 (990)
Effective headroom – rear, mm (with sunroof)	1007 (972)	1007 (972)
Elbow width, front, mm	1506	1506
Elbow width, rear, mm	1506	1506
Legroom front, mm	1045	TBA
Legroom rear, mm	973	TBA

Maximum luggage capacity, litres VDA measuring method using 200 x 100 x 50mm blocks	Passat Estate	New Passat Alltrack
With rear seats upright	650	639
With rear seats folded	1780	1769

On illustrations, where arrows and figures are shown inside of the vehicle, the measurements are for interior dimensions. Where arrows and figures are shown outside of the vehicle, the measurements are for exterior dimensions.

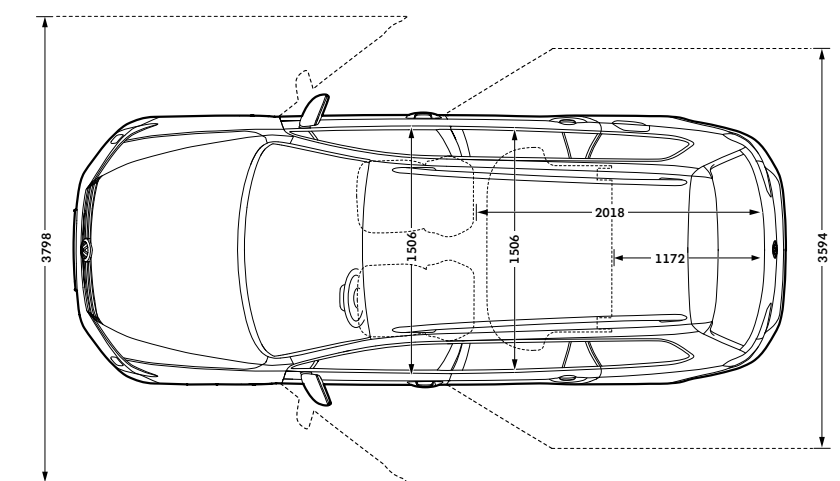
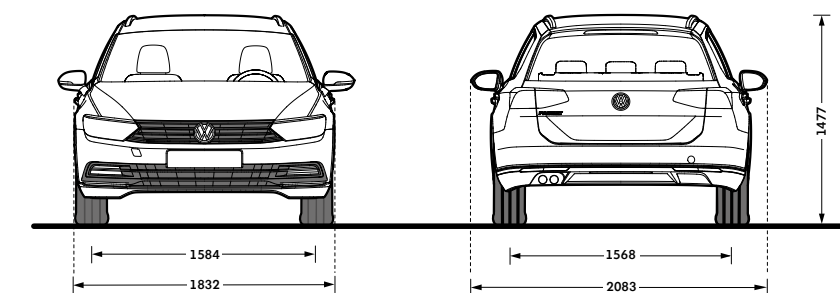
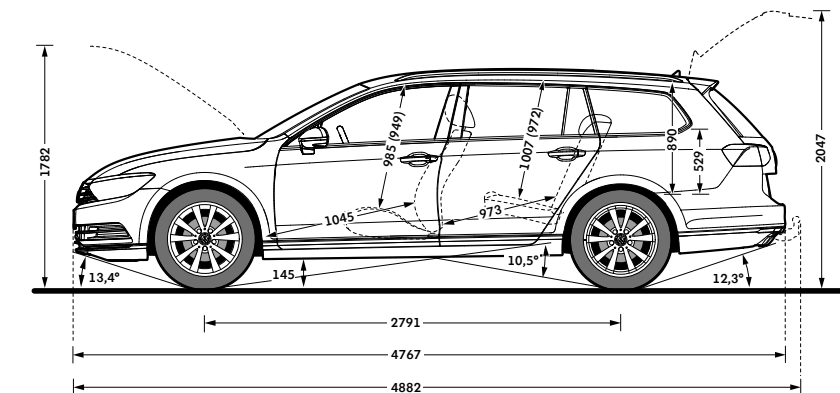

CO₂ emissions and VED bands with optional wheels.

Effect of wheel size on CO₂ emissions and VED Bands

Choosing larger alloy wheels than standard as an option, may result in increased fuel consumption as well as higher CO₂ emissions and subsequently increased Vehicle Excise Duty (VED) band and BIK rates paid for company car drivers will increase. This is due to the fact that larger wheels have both more aerodynamic drag and more mechanical drag, resulting in increased rolling resistance and increased wind resistance. As a result, the VED band that the vehicle falls into may increase from its original VED band when fitted with standard size wheels. In some instances, the 'On the Road' cost paid for the vehicle may increase as a result of the increased VED rate.

The chart below shows CO₂ emissions and the related VED bands for vehicles with both standard-fit wheels and larger optional alloy wheels, as well as the increased cost payable due to a change in VED band.

			Output, PS	Standard wheel size	CO ₂ emission, g/km, standard wheels	Maximum VED Band, standard wheels	Optional alloy wheel and size	CO ₂ emission, g/km, optional alloy wheels
4-door saloon range	S	1.6 ltr TDI BMT	6 speed manual	120	105	B	N/A	N/A
		1.6 ltr TDI BMT	7 speed auto DSG	120	103	B	N/A	N/A
		2.0 ltr TDI BMT	6 speed manual	150	106	B	N/A	N/A
		2.0 ltr TDI BMT	6 speed auto DSG	150	116	C	N/A	N/A
BlueMotion	1.6 ltr TDI SCR BM	6 speed manual	120	95	A	17" Istanbul	95	
SE	1.6 ltr TDI BMT	6 speed manual	120	105	B	16" Sepang, 17" Nivelles Anthracite, 17" Soho	105	
		6 speed manual	120	105	B	18" Oxford Anthracite, 18" Marseille Anthracite	109	
	1.6 ltr TDI BMT	7 speed auto DSG	120	103	B	16" Sepang, 17" Nivelles Anthracite, 17" Soho	103	
		7 speed auto DSG	120	103	B	18" Oxford Anthracite, 18" Marseille Anthracite	106	
	2.0 ltr TDI BMT	6 speed manual	150	106	B	16" Sepang, 17" Nivelles Anthracite, 17" Soho	106	
		6 speed manual	150	106	B	18" Oxford Anthracite, 18" Marseille Anthracite	109	
	2.0 ltr TDI BMT	6 speed auto DSG	150	116	C	16" Sepang, 17" Nivelles Anthracite, 17" Soho	116	
		6 speed auto DSG	150	116	C	18" Oxford Anthracite, 18" Marseille Anthracite	119	
SE Business	1.6 ltr TDI BMT	6 speed manual	120	105	B	16" Sepang, 17" Nivelles Anthracite, 17" Soho	105	
		6 speed manual	120	105	B	18" Oxford Anthracite, 18" Marseille Anthracite	109	
	1.6 ltr TDI BMT	7 speed auto DSG	120	103	B	16" Sepang, 17" Nivelles Anthracite, 17" Soho	103	
		7 speed auto DSG	120	103	B	18" Oxford Anthracite, 18" Marseille Anthracite	106	
	2.0 ltr TDI BMT	6 speed manual	150	106	B	16" Sepang, 17" Nivelles Anthracite, 17" Soho	106	
		6 speed manual	150	106	B	18" Oxford Anthracite, 18" Marseille Anthracite	109	
	2.0 ltr TDI BMT	6 speed auto DSG	150	116	C	16" Sepang, 17" Nivelles Anthracite, 17" Soho	116	
		6 speed auto DSG	150	116	C	18" Oxford Anthracite, 18" Marseille Anthracite	119	
GT	1.6 ltr TDI BMT	6 speed manual	120	109	B	18" Marseille Anthracite, 19" Verona	109	
		7 speed auto DSG	120	106	B	18" Marseille Anthracite, 19" Verona	106	
	2.0 ltr TDI BMT	6 speed manual	150	109	B	18" Marseille Anthracite, 19" Verona	109	
	2.0 ltr TDI BMT	6 speed auto DSG	150	119	C	18" Marseille Anthracite, 19" Verona	119	
	2.0 ltr TDI SCR BMT	6 speed manual	190	107	B	18" Marseille Anthracite, 19" Verona	107	
		6 speed auto DSG	190	119	C	18" Marseille Anthracite, 19" Verona	119	
	2.0 ltr BiTDI SCR BMT 4MOTION	7 speed auto DSG	240	139	E	18" Marseille Anthracite, 19" Verona	139	
		7 speed auto DSG	240	139	E	18" Marseille Anthracite, 19" Verona	139	
R-Line	2.0 ltr TDI BMT	6 speed manual	150	109	B	19" Verona	109	
		6 speed auto DSG	150	119	C	19" Verona	119	
	2.0 ltr TDI SCR BMT	6 speed manual	190	107	B	19" Verona	107	
		6 speed auto DSG	190	119	C	19" Verona	119	
	2.0 ltr BiTDI SCR BMT 4MOTION	7 speed auto DSG	240	139	E	19" Verona	139	
		7 speed auto DSG	240	139	E	19" Verona	139	

			Output, PS	Standard wheel size	CO ₂ emission, g/km, standard wheels	Maximum VED Band, standard wheels	Optional alloy wheel and size	CO ₂ emission, g/km, optional alloy wheels
5-door estate range	S	1.6 ltr TDI BMT	6 speed manual	120	107	B	N/A	N/A
		1.6 ltr TDI BMT	7 speed auto DSG	120	104	B	N/A	N/A
		2.0 ltr TDI BMT	6 speed manual	150	107	B	N/A	N/A
		2.0 ltr TDI BMT	6 speed auto DSG	150	119	C	N/A	N/A
BlueMotion	1.6 ltr TDI SCR BM	6 speed manual	120	95	A	17" Istanbul	95	
SE	1.6 ltr TDI BMT	6 speed manual	120	107	B	16" Sepang, 17" Nivelles Anthracite, 17" Soho	107	
		6 speed manual	120	107	B	18" Oxford Anthracite, 18" Marseille Anthracite	110	
	1.6 ltr TDI BMT	7 speed auto DSG	120	104	B	16" Sepang, 17" Nivelles Anthracite, 17" Soho	104	
		7 speed auto DSG	120	104	B	18" Oxford Anthracite, 18" Marseille Anthracite	107	
	2.0 ltr TDI BMT	6 speed manual	150	107	B	16" Sepang, 17" Nivelles Anthracite, 17" Soho	107	
		6 speed manual	150	107	B	18" Oxford Anthracite, 18" Marseille Anthracite	110	
	2.0 ltr TDI BMT	6 speed auto DSG	150	119	C	16" Sepang, 17" Nivelles Anthracite, 17" Soho	119	
		6 speed auto DSG	150	119	C	18" Oxford Anthracite, 18" Marseille Anthracite	122	
SE Business	1.6 ltr TDI BMT	6 speed manual	120	107	B	16" Sepang, 17" Nivelles Anthracite, 17" Soho	107	
		6 speed manual	120	107	B	18" Oxford Anthracite, 18" Marseille Anthracite	110	
	1.6 ltr TDI BMT	7 speed auto DSG	120	104	B	16" Sepang, 17" Nivelles Anthracite, 17" Soho	104	
		7 speed auto DSG	120	104	B	18" Oxford Anthracite, 18" Marseille Anthracite	107	
	2.0 ltr TDI BMT	6 speed manual	150	107	B	16" Sepang, 17" Nivelles Anthracite, 17" Soho	107	
		6 speed manual	150	107	B	18" Oxford Anthracite, 18" Marseille Anthracite	110	
	2.0 ltr TDI BMT	6 speed auto DSG	150	119	C	16" Sepang, 17" Nivelles Anthracite, 17" Soho	119	
		6 speed auto DSG	150	119	C	18" Oxford Anthracite, 18" Marseille Anthracite	122	
GT	1.6 ltr TDI BMT	6 speed manual	120	110	B	18" Marseille Anthracite, 19" Verona	110	
		7 speed auto DSG	120	107	B	18" Marseille Anthracite, 19" Verona	107	
	2.0 ltr TDI BMT	6 speed manual	150	110	B	18" Marseille Anthracite, 19" Verona	110	
	2.0 ltr TDI BMT	6 speed auto DSG	150	122	C	18" Marseille Anthracite, 19" Verona	122	
	2.0 ltr TDI SCR BMT	6 speed manual	190	110	B	18" Marseille Anthracite, 19" Verona	110	
		6 speed auto DSG	190	120	C	18" Marseille Anthracite, 19" Verona	120	
	2.0 ltr BiTDI SCR BMT 4MOTION	7 speed auto DSG	240	140	E	18" Marseille Anthracite, 19" Verona	140	
		7 speed auto DSG	240	140	E	18" Marseille Anthracite, 19" Verona	140	
Alltrack	2.0 ltr TDI SCR BMT 4MOTION	6 speed manual	150	130	D	19" Albertville	130	
	2.0 ltr TDI SCR BMT 4MOTION	6 speed auto DSG	190	137	E	19" Albertville	137	
R-Line	2.0 ltr TDI BMT	6 speed manual	150	110	B	19" Verona	110	
		6 speed auto DSG	150	122	C	19" Verona	122	
	2.0 ltr TDI SCR BMT	6 speed manual	190	110	B	19" Verona	110	
		6 speed auto DSG	190	120	C	19" Verona	120	
	2.0 ltr BiTDI SCR BMT 4MOTION	7 speed auto DSG	240	140	E	19" Verona	140	

Please note: the increase in VED rate that is payable is in addition to the cost of the optional alloy wheels. Please consult your Volkswagen retailer for full details. SCR (Selective Catalytic Reduction) requires AdBlue®, please see www.volkswagen.co.uk/technology/adblue for more details. [BMT](#) refers to [BlueMotion Technology](#). [BM](#) refers to [BlueMotion](#).

Volkswagen service.

Three-year Warranty

All Volkswagen passenger cars come with a three-year/60,000 miles warranty, which protects your car against the failure of most technical and electrical components due to manufacturing defects. This comprises a two-year manufacturer's warranty with unlimited mileage plus a further one-year/60,000 miles (whichever is soonest) Retailer Warranty¹. Should the mileage exceed 60,000 miles within the first two years, the manufacturer's two-year warranty will still be valid. Full details of the three-year warranty are available from your authorised Volkswagen retailer or repairer.

Body Protection Warranty

The internal body sections and panels of the Passat are covered against rusting through from the inside for 12 years. Naturally, the vehicle must be cared for in compliance with the operating instructions. Please consult your authorised Volkswagen retailer or repairer for full warranty details.

Three-year Paintwork Warranty

This latest warranty, pioneered by Volkswagen, really provides you with the widest possible cover on a new car. There are no special conditions attached and paintwork manufacturing defects will be rectified without charge. Naturally, during the warranty period the car must be cared for in compliance with the operating instructions.

Approved Accessories

A comprehensive range of accessories from alloy wheels to carpet mats is available to complement the factory-fitted option list. Volkswagen approved accessories purchased from and fitted by your authorised Volkswagen retailer at the point of vehicle sale will also benefit from the three-year vehicle warranty.

Extended Warranty

If you order the Volkswagen Extended Warranty as an option when buying your new Passat then you get the 100% Volkswagen Warranty and you can continue to enjoy comprehensive Volkswagen protection against many unforeseeable repair costs. Designed to your needs, you can purchase an extra one or two year's warranty up to a maximum of five years or 90,000 miles.

Service Intervals

Volkswagen is pleased to offer you a choice on how your Volkswagen is serviced. The appropriate selection is entirely dependent on how the car is likely to be driven and its general use. To help you identify which type of service would be most suitable, please refer to the following guide.

The Fixed Service is recommended for vehicles that will cover less than 10,000 miles in 12 months and if the vehicle is likely to be used in the following way:

- Predominantly urban driving, short journeys with frequent cold starts.
- Activities regularly producing high engine loading, e.g. frequent hill climbs, driving with vehicle fully loaded and towing.
- Uneconomical driving style using high rpms with heavy acceleration and heavy braking.

The service intervals for the Fixed Service are as follows:

- Oil change service – After 1 year or 10,000 miles (15,000km), whichever is soonest.
- Inspection service² – First after 2 years or 20,000 miles (30,000km), then every one year or 20,000 miles (30,000km), whichever is soonest.

The Flexible Service is recommended for vehicles with daily mileage of more than 25 miles where the vehicle is driven regularly mainly on longer distance journeys. The vehicle is driven mainly at a constant speed with minimum vehicle and engine loading, minimal towing and driven in an economical manner. With the Flexible Service the vehicle can cover anywhere between 10,000³ and a maximum of 20,000³ miles or 24 months (whichever is soonest) between oil changes.

The service intervals for the Flexible Service are as follows:

- Oil change service – According to flexible service interval display (after 2 years at the latest).
- Inspection service² – First after 2 years or 20,000 miles (30,000km), then every one year or 20,000 miles (30,000km), whichever is soonest.

The up! model is only available with the Fixed Service schedule. Please consult your authorised Volkswagen retailer or repairer for advice and full details.

Please note: If you purchase a Volkswagen Fixed Price Service Plan your vehicle will follow the Fixed Service schedule.

Volkswagen Insurance⁴

We want you to start enjoying your new car from day one and thanks to Volkswagen Insurance complimentary seven day cover, you can. Call free on 0800 316 7892 (lines are open Monday to Friday 8am – 9pm and Saturday 9am – 5pm), provide a few details and a cover note will be sent to your retailer. They will then tax your car and you can drive it away.

Volkswagen Ensurance⁵

Get three years' Volkswagen Ensurance cover for free.

Another great benefit of being a Volkswagen driver. If your Volkswagen was damaged in an accident, wouldn't you want it fixed by a Volkswagen trained technician using only genuine Volkswagen parts? Ensurance is Volkswagen's accident and repair cover which does exactly that. It works alongside your main comprehensive motor insurance policy no matter who you are insured with, to make sure you get the quality repair and service you would want. If you're involved in an accident or your car is stolen, just one call to us and we'll look after your claim from start to finish ensuring your Volkswagen is restored to the highest standard.

Activate your cover and benefit from:

- A guarantee that your Volkswagen will be repaired in a Volkswagen Insurance approved repairer, by Volkswagen trained technicians, using only genuine Volkswagen parts and paints.
- A dedicated Claims Manager will manage your claim from start to finish, liaising with your insurer and the repairer so you don't have to.
- Help to recover any uninsured losses using our Legal Expenses Cover.
- Online claims tracking so you can keep up to date with the status of any claim.

Volkswagen Ensurance is free to all Volkswagen customers for three years and it only takes a minute to get cover. To find out more and to activate your cover, visit volkswagen-ensurance.co.uk

Volkswagen Finance⁶

Volkswagen Finance specialises in providing funding solutions for Volkswagen drivers. Whether your Volkswagen is for private or business use, you can choose from a range of funding options.

- Solutions – a personal contract plan
- Hire purchase
- Lease purchase
- Finance lease
- Contract hire

With all Volkswagen Finance products you can choose a fixed-cost maintenance plan to help you budget for your servicing and maintenance costs. No matter what finance product you choose, your local Volkswagen retailer will be able to provide you with a personalised quote that could meet your budget and vehicle needs.

CO₂ Emissions

Increased weight of a vehicle, including higher trim levels and the addition of options will have a detrimental influence on the level of fuel consumption and CO₂ emissions produced.

The CO₂ and fuel consumption figures are obtained from tests on a representative vehicle of the type, conducted and approved in accordance with Council Directive 80/1268/EEC as amended by Directive 1999/100/EC (or later) on the approximation of the laws of the member states relating to the carbon dioxide emissions and the fuel consumption of motor vehicles.

AdBlue[®]

Diesel engines with SCR (Selective Catalytic Reduction) technology require AdBlue[®] which must be kept topped up. Please see www.volkswagen.co.uk/technology/adblue for more details.

Volkswagen Roadside Assistance

Every new car is registered for Volkswagen Roadside Assistance for one year except the Touareg and Phaeton which are registered for three years. This provides vehicle roadside and home recovery in the unlikely event of a breakdown in the UK and Europe (subject to conditions). Volkswagen Roadside Assistance can also be purchased for subsequent years. For full details, please contact your authorised Volkswagen retailer.

Tax Free Sales

For full details, please contact your authorised Volkswagen retailer.

Please note:

Some illustrations in this brochure do not necessarily reflect UK specifications and may not be available. In particular, controls and some items of equipment are positioned differently for the UK. The specifications contained in this brochure are for information purposes only and are subject to change. If you require any specific feature, you must consult your authorised Volkswagen retailer who is regularly updated with any change in specification. Please check model availability and full specification details with your authorised Volkswagen retailer prior to ordering. Note: we would like to advise you that telephone calls to Volkswagen Customer Care may be monitored and recorded as part of our training and quality assurance processes. All our monitoring and recording processes meet Ofcom regulations.

¹ All warranty work must be completed by an authorised Volkswagen retailer or repairer.
² The inspection service first at 3 years (or 40,000 miles) and then every second year (or 40,000 miles) has additional workscope.
³ The quoted mileage is based on a conversion from kilometres and is therefore unlikely to exceed circa 18,000 miles between oil changes.
⁴ Volkswagen Insurance is a trading name of Volkswagen Insurance Service (Great Britain) Limited, an appointed representative of Volkswagen Financial Services (UK) Limited, Brunswick Court, Yeomans Drive, Blakelands, Milton Keynes MK14 5LR. Registered in England number 2835230. Volkswagen Insurance is sold, underwritten and administered by Allianz Insurance plc registered in England number 84638. Registered office 57 Ladymead, Guildford, Surrey GU1 1DB. Volkswagen Financial Services (UK) Limited and Allianz Insurance plc are authorised and regulated by the Financial Services Authority. Volkswagen Financial Services (UK) Limited and Allianz Insurance plc are not part of the same corporate group.
⁵ Ensurance from Volkswagen Insurance is sold and administered by Lawshield UK Limited, registered in England number: 3360532 (registered office: Lawshield House, 850 Ibis Court, Lakeside Drive, Centre Park, Warrington, Cheshire WA1 1RL) and underwritten by UK General Insurance Limited on behalf of Ageas Insurance Limited, registered in England number: 354568 (registered office: Ageas House, Tollgate, Eastleigh, Hampshire SO53 3YA).
⁶ Finance is available to 18s and over, subject to status. Terms and conditions apply. Volkswagen Finance.

The Passat and Passat Estate

Volkswagen Information Service. Telephone: 0800 333 666

Internet: www.volkswagen.co.uk

© Volkswagen Group United Kingdom Limited 2015.

Issue: 1 August 2015. Printed in UK.

PVV925PASNEW



facebook.com/VolkswagenUK



[@UKVolkswagen](https://twitter.com/UKVolkswagen)



youtube.com/UKVolkswagen