



# PEUGEOT 308

Hatchback

Price & Specification Guide

April 2016 Version 2

Model Year 2016



PEUGEOT



Presented by engine technology International magazine

1-litre to 1.4-litre  
PSA Peugeot Citroën  
1.2-litre three-cylinder turbo

# SPECIFICATION OVERVIEW

## GT



### Engine

- Choice of:
  - 1.6 e-THP 205 hp 6 speed manual
  - 2.0 BlueHDi 180 hp 6 speed automatic

### Exterior features

- Front bumper mounted air intakes (in lieu of fog lights) in black lacquered surround
- Lowered ride height (7mm at front, 10mm at rear)

### Interior features

- Mistral Nappa GT style leather steering wheel with red stitching and GT badge
- Driver Sport Pack

### Comfort and convenience

- Peugeot Open & Go system (keyless entry & push button start)
- Driver Assistance Pack: Dynamic Cruise Control, Emergency Collision Alert & Emergency Collision Braking System

GT LINE +

## GT LINE



### Exterior features

- 18" Diamant alloy wheels
- Twin exhaust effect trim with piano black detail surround
- Dark Tinted rear side & tailgate windows
- Front LED sequential indicators
- Front LED foglights

### Comfort and convenience

- Reversing camera

### Interior features

- Mistral Nappa GT style leather steering wheel with red stitching
- GT style carpet mats
- Aluminium style pedals and door sills

ALLURE +

## ALLURE



### Exterior features

- 17" Rubis alloy wheels (Note: 16" Alloy wheels std on Allure 1.6 BlueHDi 120)
- Front fog lights
- Full LED headlamps with fully integrated LED daytime running lights

### Comfort and convenience

- Front & rear parking sensors
- Power folding door mirrors with courtesy approach lighting
- Automatic electric parking brake

ACTIVE +

## ACTIVE



### Exterior features

- 16" Quartz alloy wheels

### Comfort and convenience

- Dual zone climate control
- Rear parking sensors
- Mistral Nappa Leather trimmed steering wheel & gearknob
- Visibility pack; Automatic headlights & windscreen wipers, electrochrome auto dimming rear view mirror

### In-car entertainment and satellite navigation

- 9.7" multifunction colour touchscreen
- Satellite navigation (includes 5 years of mapping updates)

### Interior features

- Manual adjustable driver lumbar support

ACCESS +

## ACCESS



### Exterior features

- Rear lamps featuring 'claw effect' LEDs
- LED daytime running lights
- 15" steel wheels with Ambre wheel trims

### Comfort and convenience

- Manual mono-zone air conditioning
- Electric 'one touch' front windows
- Remote controlled central locking
- Cruise control with speed limiter

### In-car entertainment

- DAB digital radio
- USB connection
- Bluetooth

|||



## SPECIFICATION OVERVIEW

### GTI 270 by PEUGEOT SPORT



#### Exterior features

- 19" 'Carbone'\* alloy wheels
- Torsen® limited slip differential
- Red painted Peugeot Sport brake calipers with 380mm front discs

#### Interior features

- GTI Bucket seats in leather effect & half alcantara with red stitching & Peugeot Sport branding
- Massage function on front seats with two intensity settings

GTI 250 +

### GTI 250 by PEUGEOT SPORT



#### GTI Styling

- 'GTI' grille with chequered flag design
- Red 'Peugeot' lettering on grille
- Sports front bumper skirts
- Red lower front bumper finisher (chrome when Ultimate Red body colour specified)
- Sports side skirts
- Large twin exhaust and black rear diffuser
- 'GTI' front wing badges
- 'GTI' tailgate badge
- Lowered ride height (11mm)
- Aluminium 'GTI' door sill finishers

#### Exterior features

- 18" 'Diamant' alloy wheels
- Tinted rear side windows
- Full LED headlamps with fully integrated LED daytime running lights
- Front LED sequential indicators

#### Comfort and convenience

- Dual zone climate control
- Cruise control with speed limiter
- Electric handbrake
- Visibility pack: Automatic headlights & windscreen wipers, electrochrome auto dimming rear view mirror
- Reversing camera
- Front & rear parking sensors
- Power folding door mirrors with courtesy approach lighting
- Peugeot Open & Go system (keyless entry & push button start)

#### In-car entertainment and satellite navigation

- 9.7" multifunction colour touchscreen
- Satellite navigation
- USB input for external audio device
- DAB digital radio
- Bluetooth
- Trip computer

#### Interior features

- Driver & front passenger seat lumbar adjustment
- Sports style seats trimmed in leather effect & half alcantara with red stitching
- Mistral Nappa GTI style leather steering wheel with red stitching
- GTI style carpet mats
- Aluminium style pedals and door sills
- Adjustable front centre armrest
- Driver sport pack



Model shown is Peugeot 308 GTi 270 with optional Nera Black metallic paint.

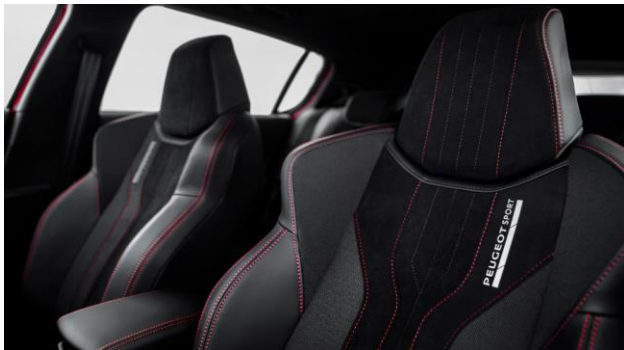

Model shown is Peugeot 308 GTi 270 with optional Coupe Franche metallic paint.

\* 19" 'Carbone' alloy wheels are 2.3kg lighter per wheel than 18" 'Diamant' and are fitted with Michelin Pilot Super Sport low profile tyres.





## KEY FEATURES - PEUGEOT 308 GTi by PEUGEOT SPORT

### Engineered By Peugeot Sport

**Engineered by Peugeot Sport:** Founded in 1981 by Jean Todt, Peugeot Sport has competed in the world's greatest and most demanding events and championships. Embarking on such endeavours has resulted in Peugeot Sport obtaining many accolades, including victories at the iconic Le Mans 24 Hours, Pikes Peak International Hill Climb and Dakar Rally. Drawing upon their expertise obtained from successes in motorsport, Peugeot Sport have designed radical sports cars for the road for many years. Peugeot 308 GTi by PEUGEOT SPORT is their latest creation, proudly carrying the name of the experts who developed it.



### 1.6L THP Turbocharged Engine

**1.6L THP Turbocharged Engine:** Available in two power outputs, 250hp and 270hp with the latter being the most powerful production engine of its size. This hugely capable engine has been meticulously developed by Peugeot Sport engineers, highlights include the fitment of Mahle lightweight race pistons, increased injection pressure and a Borgwarner twin scroll turbo charger.

This expertise results in a car that can go from 0-62mph in 6.0 seconds\* and an unrivalled power : weight ratio in the segment.

\* 270hp version



### Torsen® Limited Slip Differential

**Torsen Limited Slip Differential:** Exclusive to PEUGEOT 308 GTi 270 by PEUGEOT SPORT is an accomplished Torsen® limited-slip differential, incorporated into the transmission to improve cornering traction. By channelling the torque to the wheel with the most grip, it allows the car to accelerate faster as it exits bends than would normally be the case.



### Driver Sport Pack

**Driver Sport Pack:** Increases responsiveness of engine and gearbox to accelerator pedal, changes instrument panel colour to red (from white), displays vehicle dynamic parameters - acceleration, power delivery, turbo and amplifies engine sound in the cabin. (Standard on GTi models).



### Braking Technology

**Braking Technology:** For powerful braking, the ventilated front brake discs have a diameter of 380mm\*. Mounted on aluminium hubs, they are pinched by four pistons (38mm and 41mm in diameter) in a vibrant red fixed caliper at the front with the Peugeot Sport\*\* signature. The rear discs have a diameter of 268mm. Together, these components deliver endurance and remarkably consistent performance in the most demanding circumstances.

\* On the 270hp version. Diameter of 330mm on the 250hp version.

\*\*Available only on the 270hp version.



### Coupe Franche Paint Option

**Coupe Franche:** Exclusive to PEUGEOT 308 GTi 270 by PEUGEOT SPORT this unique paint option combines Ultimate Red and Nera Black metallic paint. This hand finished option is a visual marker for the most high performance Peugeot models.



**MANUFACTURER'S RECOMMENDED PRICES - PEUGEOT 308**

April 2016 Version 2

	ENGINE	HP	TITRE CODE (DIALOG DESCRIPTION)	CO <sub>2</sub> g/km	BASIC MRRP	VAT (£)	TOTAL MRRP	P11D VALUE (£)	2016/17 BIK %	ON THE ROAD MRRP
<b>ACCESS</b>	<b>1.2L PureTech 82</b> 5-speed manual	82	<b>1PT9A5FKQ5TOA0B6</b> (308 ACC PT82)	114	12,315.83	2,463.17	14,779.00	15,440.00	19	<b>15,495.00</b>
	<b>1.6L BlueHDi 100 S&amp;S</b> 5-speed manual	99	<b>1PT9A5FKEJTOA0B6</b> (308 ACC BHD1100)	94	14,107.50	2,821.50	16,929.00	17,590.00	18	<b>17,645.00</b>
<b>ACTIVE</b>	<b>1.2L PureTech 110 S&amp;S</b> 5-speed manual	110	<b>1PT9A5LCQJTOBMB6</b> (308 ACT PT110)	95	14,940.83	2,988.17	17,929.00	18,590.00	16	<b>18,645.00</b>
	<b>1.2L PureTech 130 S&amp;S</b> 6-speed manual	131	<b>1PT9A5LCRKTOA0B6</b> (308 ACT PT130)	104	15,399.17	3,079.83	18,479.00	19,140.00	17	<b>19,195.00</b>
	<b>1.2L PureTech 130 EAT6 S&amp;S</b> 6-speed Efficient Automatic Transmission	131	<b>1PT9A5LCRQTOA0B6</b> (308 ACT PT130A)	106	16,232.50	3,246.50	19,479.00	20,140.00	18	<b>20,195.00</b>
	<b>1.6L BlueHDi 100 S&amp;S</b> 5-speed manual	99	<b>1PT9A5LKEJTOA0B6</b> (308 ACT BHD1100)	94	15,524.17	3,104.83	18,629.00	19,290.00	18	<b>19,345.00</b>
	<b>1.6L BlueHDi 120 S&amp;S</b> 6-speed manual	120	<b>1PT9A5LKDKTOBMB6</b> (308 ACT BHD1120)	82	16,357.50	3,271.50	19,629.00	20,290.00	18	<b>20,345.00</b>
	<b>1.6L BlueHDi 120 EAT6 S&amp;S</b> 6-speed Efficient Automatic Transmission	120	<b>1PT9A5LKDQTOA0B6</b> (308 ACT BHD1120A)	92	17,190.83	3,438.17	20,629.00	21,290.00	18	<b>21,345.00</b>
<b>ALLURE</b>	<b>1.2L PureTech 110 S&amp;S</b> 5-speed manual	110	<b>1PT9A5PCQJTOA0B6</b> (308 ALL PT110)	107	15,774.17	3,154.83	18,929.00	19,590.00	18	<b>19,645.00</b>
	<b>1.2L PureTech 130 S&amp;S</b> 6-speed manual	131	<b>1PT9A5PCRKTOA0B6</b> (308 ALL PT130)	107	16,399.17	3,279.83	19,679.00	20,340.00	18	<b>20,395.00</b>
	<b>1.2L PureTech 130 EAT6 S&amp;S</b> 6-speed Efficient Automatic Transmission	131	<b>1PT9A5PCRQTOA0B6</b> (308 ALL PT130A)	112	17,232.50	3,446.50	20,679.00	21,340.00	19	<b>21,395.00</b>
	<b>1.6L BlueHDi 120 S&amp;S</b> 6-speed manual	120	<b>1PT9A5PKDKTOBMB6</b> (308 ALL BHD1120)	84	17,357.50	3,471.50	20,829.00	21,490.00	18	<b>21,545.00</b>
	<b>1.6L BlueHDi 120 EAT6 S&amp;S</b> 6-speed Efficient Automatic Transmission	120	<b>1PT9A5PKDQTOA0B6</b> (308 ALL BHD1120A)	98	18,190.83	3,638.17	21,829.00	22,490.00	19	<b>22,545.00</b>
	<b>2.0L BlueHDi 150 S&amp;S</b> 6-speed manual	150	<b>1PT9A5PKBKTOA0B7</b> (308 ALL BHD1150)	102	18,107.50	3,621.50	21,729.00	22,390.00	20	<b>22,445.00</b>
	<b>2.0L BlueHDi 150 EAT6 S&amp;S</b> 6-speed Efficient Automatic Transmission	150	<b>1PT9A5PKBQTOA0B6</b> (308 ALL BHD1150A)	105	18,940.83	3,788.17	22,729.00	23,390.00	21	<b>23,445.00</b>
<b>GT LINE</b>	<b>1.2L PureTech 130 S&amp;S</b> 6-speed manual	131	<b>1PT9A5TCRKTOA0B6</b> (308 GTL PT130)	107	17,690.83	3,538.17	21,229.00	21,890.00	18	<b>21,945.00</b>
	<b>1.2L PureTech 130 EAT6 S&amp;S</b> 6-speed Efficient Automatic Transmission	131	<b>1PT9A5TCRQTOA0B6</b> (308 GTL PT130A)	112	18,524.17	3,704.83	22,229.00	22,890.00	19	<b>22,945.00</b>
	<b>1.6L BlueHDi 120 S&amp;S</b> 6-speed manual	120	<b>1PT9A5TKDKTOA0B6</b> (308 GTL BHD1120)	98	18,649.17	3,729.83	22,379.00	23,040.00	19	<b>23,095.00</b>
	<b>1.6L BlueHDi 120 EAT6 S&amp;S</b> 6-speed Efficient Automatic Transmission	120	<b>1PT9A5TKDQTOA0B6</b> (308 GTL BHD1120A)	98	19,482.50	3,896.50	23,379.00	24,040.00	19	<b>24,095.00</b>
	<b>2.0L BlueHDi 150 S&amp;S</b> 6-speed manual	150	<b>1PT9A5TKBKTOA0B7</b> (308 GTL BHD1150)	102	19,399.17	3,879.83	23,279.00	23,940.00	20	<b>23,995.00</b>
	<b>2.0L BlueHDi 150 EAT6 S&amp;S</b> 6-speed Efficient Automatic Transmission	150	<b>1PT9A5TKBQTOA0B6</b> (308 GTL BHD1150A)	105	20,232.50	4,046.50	24,279.00	24,940.00	21	<b>24,995.00</b>
<b>GT</b>	<b>1.6L THP 205 S&amp;S</b> 6-speed manual	205	<b>1PT9A5UKJKTOA0B6</b> (308 GT THP205)	130	19,899.17	3,979.83	23,879.00	24,540.00	23	<b>24,595.00</b>
	<b>2.0L BlueHDi EAT6 180 S&amp;S</b> 6-speed Efficient Automatic Transmission	181	<b>1PT9A5UKAQTOA0B6</b> (308 GT BHD1180A)	103	21,440.83	4,288.17	25,729.00	26,390.00	20	<b>26,445.00</b>
<b>GTI 250 by PS</b>	<b>1.6L THP 250 S&amp;S</b> 6-speed manual	250	<b>1PT9A5WLJKTOA0B6</b> (308 GTI THP250)	139	21,674.17	4,334.83	26,009.00	26,670.00	24	<b>26,855.00</b>
<b>GTI 270 by PS</b>	<b>1.6L THP 270 S&amp;S</b> 6-speed manual	272	<b>1PT9A5WLMKTOA0B6</b> (308 GTI THP270)	139	23,007.50	4,601.50	27,609.00	28,270.00	24	<b>28,455.00</b>



Model shown is Peugeot 308 GT with optional Magnetic Blue metallic paint.



PureTech Petrol Engine Technology



**Peugeot PureTech: Compact engine – huge spirit**

Peugeot PureTech is advanced 3-cylinder petrol engine technology that offers a drive and performance normally associated with much bigger engines but with significantly improved fuel consumption and CO<sub>2</sub> emissions<sup>1</sup>. It's a product of Peugeot's 100 years of intelligent, innovative engineering and combines reduced weight materials with the efficiency of applying direct fuel injection to three cylinders. On some versions we've even added Turbo power, optimising torque at all revs and delivering an engine with a unique personality and one which is ultimately designed to give you maximum driving pleasure and responsiveness, at any speed, for less.

<sup>(1</sup>comparison based on New 308 1.2L PureTech110 S&S vs New 308 1.6 THP 125)



**Peugeot PureTech: The Record Breaker.....**

The award winning Peugeot 308 fitted with the award winning 1.2l PureTech 130 S&S set a new record for production car fuel economy & distance.

- 1.2l PureTech 130 S&S managed **99.1mpg** & covered **1,125** miles on one tank of fuel.
- Officially witnessed by the authority UTAC (Union Technique de l'Automobile, Motocycle et Cycle).
- Driven for over 32 hours to consume the 51.4-litre contents of its fuel tank.

**Peugeot PureTech: The Award Winner.....**

PureTech technology was awarded the hugely impressive accolade of 'International Engine of the Year 2015' award for the 1.0l -1.4l category with a panel of 65 industry experts from 31 countries coming to the unanimous decision, forcing Volkswagen's 1.4-litre TSI Twincharger unit into second place.

- "The new PureTech engine from PSA is a **revelation** in terms of refinement, performance and efficiency," stated German journalist Thomas Imhof.
- "Without turbo lag, this three-cylinder gives a lot of power and perfect torque at very low revs, with a harmonious noise throughout the whole range. And the consumption is very low," agreed L'Automobile Magazine's Christophe Congrega.



**1-litre to 1.4-litre**  
PSA Peugeot Citroën  
1.2-litre three-cylinder turbo

BlueHDi Diesel Engine Technology



**Peugeot BlueHDi : Pioneering on MPG and CO<sub>2</sub>**

BlueHDi is the name given to Peugeot's latest generation of diesel engines. The result of a world-famous diesel heritage plus innovation and engineering excellence developed on the race track of Le Mans, BlueHDi complies with Euro 6\* emission standards, to deliver exceptional fuel economy and CO<sub>2</sub> emissions alongside a driving experience rich in power and performance.

A three stage cleansing process specifically targets the pollutants of diesel combustion, removing hydrocarbons and carbon monoxide, reducing nitrogen oxides by up to 90% and eliminating 99.9%<sup>ii</sup> of particulates. BlueHDi delivers the cleanest diesel engine possible and exceptional fuel economy of up to 91mpg with CO<sub>2</sub> as low as 82g/km<sup>iii</sup>.

<sup>(ii</sup>by number <sup>iii</sup>model and version dependent)



- Peugeot 308 Active 1.6L BlueHDi 120 S&S awarded 'Best SME Company Car To Buy 2015' by Business Car Manager magazine, in recognition of its 'ultra clean 1.6l diesel engine'.



Efficient Automatic Transmission (EAT6) Technology

**EAT6 (Efficient Automatic Transmission):**

**New generation of AISIN 6-speed automatic gearboxes**

Peugeot's new generation of automatic gearboxes have been developed in collaboration with Aisin AW. EAT6 uses Quickshift technology, for faster gear changes and smooth operation, delivering superb driving pleasure and exceptional fuel and CO<sub>2</sub> efficiency.



Safety



Here at Peugeot, safety is of paramount importance, with this in mind every part of Peugeot 308 has been designed to protect you and those dearest to you. In recognition of this Peugeot 308 was awarded a five star rating – the highest rating possible – from Euro NCAP, the most widely-recognised independent vehicle safety assessor in Europe, following extensive and rigorous crash testing.

**Airbags:** Peugeot 308 offers optimum protection for you and your family. All models features 6 airbags as standard. Airbag protection comprises:

**Driver & front passenger airbags:** providing frontal protection for front seat occupants. Front passenger airbag can be deactivated to allow for the fitment of a child seat.

**Front side airbags:** located in the seat frame on the outside edge of the front seats; they inflate between front seat occupants and the front doors, providing thorax, abdomen and pelvis protection in a side impact.

**Curtain airbags:** located either side of 308, these deploy in a side impact and provide head protection for both front and rear occupants in a side impact.

In addition, deployment of the airbags causes the fuel supply to be cut off, doors will automatically unlock, hazard warning lamps will activate and Peugeot Connect SOS (if specified) will automatically trigger and contact the emergency services if no response is received from occupants onboard.



## KEY FEATURES - PEUGEOT 308

### Driver Assistance Pack

**Driver Assistance Pack:** Advanced safety pack controlled by a radar mounted within the front bumper. Pack comprises:

**Dynamic Cruise Control:** ('intelligent' cruise control that can use engine braking to maintain a set distance between 308 and the car in front).

**Emergency Collision Alert System:** (an audible & visual alert to the driver to take action to avoid a collision).

**Emergency Collision Braking System:** (if a collision is imminent 308 makes an automatic brake application to reduce speed by a maximum of 12mph to reduce the severity of impact).  
(Optional on Allure & GT Line, standard on GT models).



### Peugeot Connect SOS & Assistance

**Peugeot Connect SOS & Assistance:** A vehicle locating communication unit, this feature can be used manually (dedicated SOS button in the roof) or automatically (if pyrotechnic devices are deployed). It locates the vehicle precisely and triggers the sending of the appropriate emergency services for a rapid response. Peugeot are the pioneers of this technology, since launching in 2003 Peugeot Connect SOS & Assistance has come to the aid of over 7,000 individuals.  
(Optional across the Peugeot 308 range).



### Peugeot Open & Go

**Peugeot Open & Go:** Using sensors mounted in the front door handles, 308 can be opened without removing the key from your pocket or bag, simply grab the handle and the vehicle will automatically unlock. Once inside a simple press of the stop start button is all that is required.  
(Optional on Allure & GT Line, standard on GT & GTi models).



### City Park

**City Park:** This system provides Active assistance for parking by detecting a parking space and then operating the steering system to park in this space. The system works with both parallel and bay parking.

**Blind Spot Monitoring:** also comes with the City park pack, this technology provides information to the driver during a journey, on the presence of a vehicle or motorcycle in the blind spot by means of four sensors mounted in the front and rear bumpers, if a vehicle is detected the driver is informed through the illumination of the LED light located in the door mirrors.  
(Optional on Allure, GT Line & GT models).



### Driver Sport Pack

**Driver Sport Pack:** Increase the sporting temperament of your Peugeot 308 with this exciting pack.  
By pressing the 'Sport' button this increases responsiveness of power steering and engine and gearbox to accelerator pedal. Other changes include instrument panel colour change to red (from white) and a change to display vehicle dynamic parameters - acceleration, power delivery, turbo.  
(Optional on Allure & GT Line, standard on GT & GTi models).



### Peugeot Connect Apps

**Peugeot Connect Apps:** An apps service that is designed to respond to all of your requirements during a journey, services include: fuel station locations and the pricing of their fuel, Trip Advisor to provide reviews of nearby attractions, restaurants, pubs, cafes & hotels. Along a journey the Michelin Traffic guide provides real time information on traffic deals around 308.  
(Optional across the Peugeot 308 range).





## KEY FEATURES CONTINUED - PEUGEOT 308

### Satellite Navigation

**Satellite Navigation:** Linked to the 9.7" colour touch screen, the system includes European mapping and comes with 5 years of free software updates.

The system also includes a point of interest function, full postcode lookup and various route planning options.

(Standard on 308 Active models and above)



### Colour Reversing Camera

**Colour Reversing Camera:** A camera located on the rear of the vehicle is linked to the 9.7" colour touch screen. The system increases visibility and driver confidence when reversing.

The camera also works in low light & features guidance lines to aid with parking.

(Optional on Allure, standard on GT Line, GT and GTi models)



### Full LED Headlamps

**Full LED Headlamps:** Light Emitting Diode (LED) technology remains a rare feature in the car industry with Peugeot 308 however this is not the case. Full LED headlamps feature from Allure level and above providing the following customer benefits:

- LED technology consumes considerably less energy to produce light, 50% less than halogen and 35% less than xenon technologies.
  - LED technology offers a whiter light for improved visibility at night, the light is also more similar to daylight, leading to reduced driver eye fatigue, improving safety.
  - LED technology requires no warm up time with instantaneous lighting response when compared to conventional halogen technologies.
  - LED technology will last for the life of the car, compared to halogen technology with much shorter life expectancy.
  - LED technology offers a very striking visual signature that perfectly complements the sharp exterior design of Peugeot 308.
- (Standard on 308 Allure models and above)

In addition all PEUGEOT 308 models feature LED daytime running lights to increase the visibility of the vehicle during daylight hours and signature Peugeot 'claw effect' LED rear lighting. This provides a nod to the iconic Peugeot 504 Coupe and Cabriolet.



#### 1. Visibility with halogen technology.



#### 2. Visibility with full LED technology.



### Panoramic Cielo Glass Roof

**Panoramic Cielo Glass Roof:** Measuring 1.44m<sup>2</sup> this large fixed panel glass roof bathes the cabin in natural light. An electric roller blind is also included, this blind is able to filter out of 95% of exterior light.

(Optional on 308 Active models and above)



### Sequential LED Front Indicators

**Sequential LED Front Indicators:** an exclusive visual marker for sport models, when signalling the front bumper mounted LED indicators scroll in an outwards formation.

(Standard on 308 GT Line, GT & GTi)

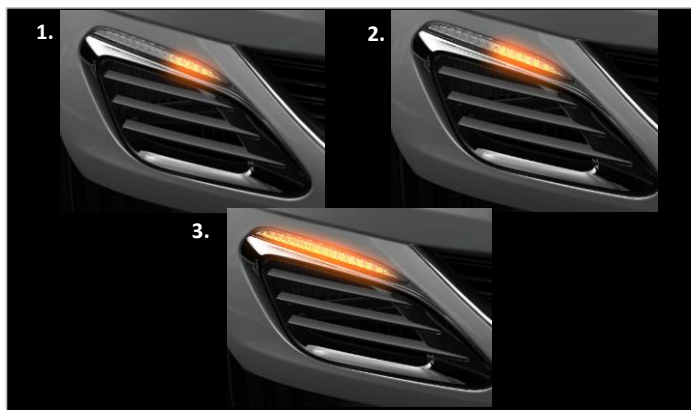



# CHOOSE YOUR OPTIONS

April 2016 Version 2

		ACCESS	ACTIVE	ALLURE	GT LINE	GT	GTI 250 by Peugeot Sport	GTI 270 by Peugeot Sport	Basic RRP £ Excluding VAT	VAT @ 20%	Total RRP £ Including VAT
<b>PAINT</b>											
Metallic paint	MO..	○	○	○	○	○	○	○	437.50	87.50	<b>525.00</b>
Pearlescent/special paint	M6../M5..	○	○	○	○	○	○	○	562.50	112.50	<b>675.00</b>
White paint	P0..	○	○	○	-	-	-	-	208.33	41.67	<b>250.00</b>
Coupe Franche paint (side window surrounds in black in conjunction with this option)	M5F3 & D369	-	-	-	-	-	-	○	1,083.33	216.67	<b>1,300.00</b>
<b>SEATING</b>											
Black Mistral leather sports style heated front seats with seat back pockets and electric lumbar adjustment. Leather rear seats with arm rest and ski flap.	8DFX	-	-	○	-	-	-	-	1,250.00	250.00	<b>1,500.00</b>
Black Mistral (with red stitching) leather sports style heated front seats with seat back pockets and electric lumbar adjustment and massage function on front seats. Leather rear seats with arm rest and ski flap.	8DFJ	-	-	-	○	○	-	-	1,000.00	200.00	<b>1,200.00</b>
GTI Bucket seats trimmed with leather effect & alcantara, red stitched with lumbar adjustment and massage function on front seats.	0JFJ	-	-	-	-	-	○	●	666.67	133.33	<b>800.00</b>
<b>SAFETY AND SECURITY</b>											
Peugeot Connect SOS and Assistance (non-touch screen models)	WLA2	○	-	-	-	-	-	-	200.00	40.00	<b>240.00</b>
Peugeot Connect SOS and Assistance (touch screen models)	WLA9	-	○	○	○	○	○	○	200.00	40.00	<b>240.00</b>
Ultrasonic alarm (Thatcham Category 1 approved)	AB08	○	●	●	●	●	●	●	150.00	30.00	<b>180.00</b>
<b>COMFORT AND CONVENIENCE</b>											
Peugeot Open and Go system (keyless entry with start/stop button)	YD01	-	-	○	○	●	●	●	345.83	69.17	<b>415.00</b>
Driver Assistance Pack (Dynamic Cruise Control, Emergency Collision Alert System and Emergency Collision Braking System)	RG17	-	-	○	○	●	-	-	375.00	75.00	<b>450.00</b>
City Park enhanced parking assistance system with blind spot monitoring (includes Colour reversing camera on Allure models)	UB10	-	-	○	○	○	-	-	333.33	66.67	<b>400.00</b>
Panoramic fixed cielo glass roof with electric interior blind (unavailable with Coupe Franche paint option on GTI 270)	OK01	-	○	○	○	○	○	○	416.67	83.33	<b>500.00</b>
Colour reversing camera	UB07	-	-	○	●	●	●	●	166.67	33.33	<b>200.00</b>
Automatic electric parking brake	FH05	-	○	●	●	●	●	●	166.67	33.33	<b>200.00</b>
Electric folding door mirrors with courtesy approach lighting	HU13	-	○	●	●	●	●	●	83.33	16.67	<b>100.00</b>
<b>IN CAR ENTERTAINMENT</b>											
Driver Sport Pack - available on PureTech 1.2 PureTech 110 S&S, 1.2 PureTech 130 S&S (manual and auto), 2.0 BlueHDI 150 manual. Standard on both GT & GTI engines.	QM02	-	-	○	○	●	●	●	308.33	61.67	<b>370.00</b>
Peugeot Connect Apps V2 - Dealer Fit Only - only compatible with vehicles equipped with Satellite Navigation		-	○	○	○	○	○	○	249.17	49.83	<b>299.00</b>
CD player (integrated within standard audio unit)	WLB5	-	○	○	○	○	○	○	100.00	20.00	<b>120.00</b>
CD player (integrated within standard audio unit) and Peugeot Connect SOS and Assistance (touch screen models)	WLB0	-	○	○	○	○	○	○	300.00	60.00	<b>360.00</b>
<b>EXTERIOR FEATURES</b>											
16" Quartz alloy wheels (with full size spare wheel)	ZH4A	-	○	-	-	-	-	-	83.33	16.67	<b>100.00</b>
16" Diamond alloy wheels Allure BlueHDI 120 (with full size spare wheel)	ZH2P	-	-	○	-	-	-	-	83.33	16.67	<b>100.00</b>
17" Rubis alloy wheels (with space saver spare wheel). Note: only available on BlueHDI 100, Puretech 130 & BlueHDI 120 EAT6 Automatic	ZH2R	-	○	-	-	-	-	-	250.00	50.00	<b>300.00</b>
17" Rubis alloy wheels (with full size spare wheel). Note: only available on BlueHDI 100, Puretech 130 & BlueHDI 120 EAT6 Automatic	ZH2S	-	○	-	-	-	-	-	333.33	66.67	<b>400.00</b>
17" Rubis alloy wheels (with full size spare wheel) Note: unavailable on Allure BlueHDI 120 Manual	ZH2S	-	-	○	-	-	-	-	83.33	16.67	<b>100.00</b>
18" Saphir alloy wheels (with space saver spare wheel) Note: unavailable on Allure BlueHDI 120 Manual	ZH2U	-	-	○	-	-	-	-	250.00	50.00	<b>300.00</b>
18" Saphir alloy wheels (with full size spare wheel) Note: unavailable on Allure BlueHDI 120 Manual	ZH2W	-	-	○	-	-	-	-	333.33	66.67	<b>400.00</b>
18" Diamant alloy wheels (with full size spare wheel)	ZH6H	-	-	-	○	○	○	-	83.33	16.67	<b>100.00</b>
19" Carbone alloy wheels (with puncture repair kit)	ZHAU	-	-	-	-	-	○	●	666.67	133.33	<b>800.00</b>
19" Carbone alloy wheels (with space saver spare wheel)	ZHAV	-	-	-	-	-	○	-	750.00	150.00	<b>900.00</b>
<b>EXTERIOR LIGHTING AND VISIBILITY</b>											
Halogen Front fog lights	PR01	○	○	●	-	-	-	-	108.33	21.67	<b>130.00</b>

# EQUIPMENT

● = Standard ○ = Option at extra cost

ACCESS	ACTIVE	ALLURE	GT LINE	GT	GTI 250 by Peugeot Sport	GTI 270 by Peugeot Sport
--------	--------	--------	---------	----	--------------------------------	--------------------------------

BODYSTYLE							
Five door HATCHBACK	●	●	●	●	●	●	●
SEATING							
Comfort seats trimmed in Metax Mistral cloth trim	●	-	-	-	-	-	-
Comfort seats trimmed in Cran charcoal grey cloth trim with overstitch detail	-	-	-	-	-	-	-
Comfort seats trimmed in Metax Mistral cloth trim with overstitch detail	-	●	-	-	-	-	-
Sports style seats in Marston Mistral cloth trim with double overstitch detail	-	-	●	-	-	-	-
Sports style seats in black Mistral half alcantara trim	-	-	-	-	-	-	-
Sports style seats trimmed in leather effect & Oxford cloth with red overstitch detail	-	-	-	●	-	-	-
Sports style seats trimmed in leather effect & half alcantara with red overstitch detail	-	-	-	-	●	●	-
GTI Bucket seats in leather effect & half alcantara with red overstitch detail, Peugeot Sport branding and massaging function on front seats	-	-	-	-	-	○	●
Height adjustment of front passenger seat	●	-	-	-	-	-	-
Height adjustment of front passenger seat, seat back pockets and lumbar adjustment for driver seat	-	●	●	-	-	-	-
Height adjustment of front passenger seat, seat back pockets and lumbar adjustment for driver & passenger seat	-	-	-	●	●	●	●
SAFETY AND SECURITY							
Driver and front passenger front and side airbags	●	●	●	●	●	●	●
Curtain airbags for front and rear windows	●	●	●	●	●	●	●
Anti-Lock Braking (ABS), Electronic Brake Force Distribution (EBFD), Emergency Braking Assistance (EBA)	●	●	●	●	●	●	●
Electronic Stability Programme (ESP)	●	●	●	●	●	●	●
Three point inertia reel seat belts on all seats	●	●	●	●	●	●	●
Ultrasonic alarm (Thatcham Category 1 approved)	○	●	●	●	●	●	●
Locking wheel bolts	-	●	●	●	●	●	●
Space saver spare wheel	●	●	●	●	●	●	-
Deadlocks	●	●	●	●	●	●	●
Rolling code transponder immobiliser	●	●	●	●	●	●	●
COMFORT AND CONVENIENCE							
Mistral Nappa leather steering wheel (non-leather on Access)	-	●	●	-	-	-	-
GT style leather steering wheel (with GT badge on GT)	-	-	-	●	●	-	-
GTI Mistral Nappa leather steering wheel with red marking, red stitch detail & satin chrome insert bearing 'GTI' logo.	-	-	-	-	-	●	●
Electric power assisted steering	●	●	●	●	●	●	●
Cruise control and speed limiter	●	-	-	-	-	-	-
Programmable cruise control and speed limiter	-	●	●	●	-	●	●
Driver Assistance Pack: Dynamic Cruise Control, Emergency Collision Alert & Emergency Collision Braking System	-	-	○	○	●	-	-
Rear parking sensors	-	●	-	-	-	-	-
Front and rear parking sensors	-	-	●	●	●	●	●
Colour reversing camera	-	-	○	●	●	●	●
Manual mono-zone air conditioning	●	-	-	-	-	-	-
Automatic dual-zone climate control	-	●	●	●	●	●	●
One-touch electric front windows	●	●	●	●	●	●	●
Manual rear windows	●	-	-	-	-	-	-
Electric rear windows	-	●	●	●	●	●	●
Electric folding door mirrors with courtesy approach lighting	-	○	●	●	●	●	●
Automatic electric parking brake (includes Hill Assist).	-	○	●	●	●	●	●
12V accessory power point front	●	●	●	●	●	●	●
Peugeot Open and Go system (keyless entry with start/stop button)	-	-	○	○	●	●	●



## EQUIPMENT (2)

● = Standard ○ = Option at extra cost

ACCESS	ACTIVE	ALLURE	GT LINE	GT	GTI 250 by Peugeot Sport	GTI 270 by Peugeot Sport
--------	--------	--------	---------	----	--------------------------------	--------------------------------

### IN CAR ENTERTAINMENT

Driver Sport Pack - optional on 1.2 PureTech 110 S&S, 1.2 PureTech 130 S&S (manual and auto), 2.0 BlueHDI 150 manual. Standard on both GT engines.	-	-	○	○	●	●	●
Peugeot Connect Sound (RD45) DAB digital radio with integrated CD player	●	-	-	-	-	-	-
DAB digital radio with 9.7" multifunction colour touch screen (without CD player)	-	●	●	-	-	-	-
DAB digital radio & 9.7" multifunction colour touch screen with 'Redline' sports theme (without CD player)	-	-	-	●	●	●	●
Satellite navigation (includes 5 years of free mapping updates)	-	●	●	●	●	●	●
Bluetooth telephone facility	●	●	●	●	●	●	●

### EXTERIOR FEATURES

Body coloured door mirror shells	●	●	●	-	-	-	-
High gloss black door mirror shells	-	-	-	●	●	●	●
Tinted rear side & tailgate windows	●	●	●	-	-	-	-
Dark Tinted rear side & tailgate windows	-	-	-	●	●	●	●
15" steel wheels with Ambre wheel trims (with space saver spare)	●	-	-	-	-	-	-
16" Quartz alloy wheels (with space saver spare)	-	●	-	-	-	-	-
16" Diamond alloy wheels (with space saver spare) 1.6 BlueHDI 120 Manual	-	-	●	-	-	-	-
17" Rubis alloy wheels (with space saver spare) Note: only available on Puretech 130, BlueHDI 100, BlueHDI 120 Auto	-	○	●	-	-	-	-
18" Diamant alloy wheels (with space saver spare)	-	-	-	●	●	●	-
19" Carbone alloy wheels (with puncture repair kit)	-	-	-	-	-	○	●
Peugeot Sport branded red brake calipers with 380mm front discs	-	-	-	-	-	-	●

### EXTERIOR LIGHTING AND VISIBILITY

Halogen front fog lights	○	○	●	-	-	-	-
LED front fog lights	-	-	-	●	-	-	-
Sequential LED front indicators	-	-	-	●	●	●	●
Halogen headlamps with bumper integrated LED daytime running lights	●	●	-	-	-	-	-
Full LED headlamps with fully integrated LED daytime running lights	-	-	●	●	●	●	●
LED rear lights	●	●	●	●	●	●	●
Automatic headlamps (with follow-me-home function) and wipers	-	●	●	●	●	●	●
Electrochrome rear view mirror	-	●	●	●	●	●	●



Model shown is Peugeot 308 GT with optional Magnetic Blue metallic paint.

# CHOOSE YOUR COLOUR

## COLOUR OPTIONS

SOLID COLOUR		METALLIC COLOURS (extra cost option)							PEARLESCENT COLOUR (extra cost option)	SPECIAL COLOUR (extra cost option)	SPECIAL COLOUR (extra cost option)
no cost option	extra cost option										
Hurricane Grey	Bianca White	Aluminium	Nero Black	Twilight Blue	Cumulus Grey	Nimbus Grey	Magnetic Blue	Pearlescent White	Ultimate Red	Coupe Franche	
P09G	POWP	M02R	M09V	M0KU	M0F4	M0VL	M0EG	M6N9	M5F3	M5F3 & D369	

● = Standard at no cost ○ = Option at extra cost

Model	Interior/Trim	Code	P09G	POWP	M02R	M09V	M0KU	M0F4	M0VL	M0EG	M6N9	M5F3	M5F3 & D369
<b>ACCESS</b>	Comfort seats trimmed in Metax Mistral cloth	1PFX	●	○	○	○	○	○	○		○	○	
<b>ACTIVE</b>	Comfort seats trimmed in Metax Mistral cloth with overstitch detail	1RFX	●	○	○	○	○	○	○		○	○	
<b>ALLURE</b>	Sports style seats in Marston Mistral cloth with double overstitch detail	0IFX	●	○	○	○	○	○	○		○	○	
	Sports style seats in Black Mistral Nappa leather (includes heated front seats)	8DFX	○	○	○	○	○	○	○		○	○	
<b>GT LINE</b>	Sports style seats trimmed in leather effect & Oxford cloth with red overstitch detail	0NFJ	●			○		○		○	○	○	
	Sports style seats trimmed in Black Mistral Nappa leather with red overstitch detail (includes heated front seats)	8DFJ	○			○		○		○	○	○	
<b>GT</b>	Sports style seats trimmed in leather effect & alcantara with red overstitch detail	1UFJ	●			○		○		○	○	○	
	Sports style seats trimmed in Black Mistral Nappa leather with red overstitch detail (includes heated front seats)	8DFJ	○			○		○		○	○	○	
<b>GTI 250 by PS</b>	Sports style seats trimmed in leather effect & half alcantara with red overstitching	1UFJ	●			○		○		○	○	○	
	GTI Bucket seats in leather effect & half alcantara with red overstitching & Peugeot Sport branding	0JFJ	○			○		○		○	○	○	
<b>GTI 270 by PS</b>	GTI Bucket seats in leather effect & half alcantara with red overstitching & Peugeot Sport branding	0JFJ	●			○		○		○	○	○	○



Hurricane Grey



Bianca White



Aluminium



Nero Black



Twilight Blue



Cumulus Grey



Nimbus Grey



Magnetic Blue



Pearlescent White



Ultimate Red



Coupe Franche



# CHOOSE YOUR INTERIOR TRIM & ALLOY WHEELS

## INTERIOR TRIM OPTIONS

● = Standard at no cost ○ = Option at extra cost

<b>ACCESS</b>	Comfort seats trimmed in Metax Mistral cloth	1PFX	●	
<b>ACTIVE</b>	Comfort seats trimmed in Metax Mistral cloth with overstitch detail	1RFX	●	
<b>ALLURE</b>	Sports style seats in Marston Mistral cloth with double overstitch detail	0IFX	●	
	Sports style seats in Black Mistral Nappa leather (includes heated front seats)	8DFX	○	
<b>GT LINE</b>	Sports style seats trimmed in leather effect & Oxford cloth with red overstitch detail	0NFJ	●	
	Sports style seats trimmed in Black Mistral Nappa leather with red overstitch detail (includes heated front seats)	8DFJ	○	
<b>GT</b>	Sports style seats trimmed in leather effect & alcantara with red overstitch detail	1UFJ	●	
	Sports style seats trimmed in Black Mistral Nappa leather with red overstitch detail (includes heated front seats)	8DFJ	○	
<b>GTI 250 by PS</b>	Sports style seats trimmed in leather effect & half alcantara with red overstitching	1UFJ	●	
	GTI Bucket seats in leather effect & half alcantara with red overstitching & Peugeot Sport branding	0JFJ	○	
<b>GTI 270 by PS</b>	GTI Bucket seats in leather effect & half alcantara with red overstitching & Peugeot Sport branding	0JFJ	●	

## ALLOY WHEEL OPTIONS

	ACCESS	ACTIVE	ALLURE	GT LINE	GT	GTI 250 by PS	GTI 270 by PS
15" steel wheels with Ambre trims	●						
16" Quartz alloy wheels		●					
16" Diamond alloy wheels			● <sup>1</sup>				
17" Rubis alloy wheels (Not available on Active & Allure BlueHDI 120 & Active Puretech 110)		○	●				
18" Saphir alloy wheels ((Not available on Allure BlueHDI 120)			○				
18" Diamant alloy wheels				●	●	●	
19" Carbone alloy wheels						○	●

**NB: Refer to option page for wheel option pricing**

**1. Allure 1.6 BlueHDI 120 manual is fitted with 16" 'Diamond' alloy wheel**



15" 'Ambre' Trim



16" 'Quartz' Alloy



16" 'Diamond' Alloy



17" 'Rubis' Alloy



18" 'Saphir' Alloy



18" 'Diamant' Alloy



19" 'Carbone' Alloy

# TECHNICAL SPECIFICATION

		Petrol						Diesel							
		1.2L PureTech 82 5-speed manual	1.2L PureTech 110 S65 5-speed manual	1.2L PureTech 130 S65 6-speed manual	1.2L PureTech 130 EAT6 S65 6-speed Efficient Automatic Transmission	1.6L THP 205 S65 6-speed manual	1.6L THP 250 S65 6-speed manual	1.6L THP 270 S65 6-speed manual	1.6L BlueHDI 100 S65 5-speed manual	1.6L BlueHDI 120 S65 6-speed manual	1.6L BlueHDI 120 EAT6 S65 6-speed Efficient Automatic Transmission	2.0L BlueHDI 150 S65 6-speed manual	2.0L BlueHDI 150 EAT6 S65 6-speed Efficient Automatic Transmission	2.0L BlueHDI 180 EAT6 S65 6-speed Efficient Automatic Transmission	
DRIVETRAIN	Fuel type	Petrol	Petrol	Petrol	Petrol	Petrol	Petrol	Petrol	Diesel	Diesel	Diesel	Diesel	Diesel	Diesel	
	Stop and Start functionality		●	●	●	●	●	●	●	●	●	●	●	●	
	Cubic capacity (cc)	1199	1199	1199	1199	1598	1598	1598	1560	1560	1560	1997	1997	1997	
	Maximum power hp (Kw)	82 (60) @ 5750	110 (81) @5500	131 (96) @ 5500	131 (96) @5500	205 (151) @6000	250 (184) @6000	272 (200) @6000	99 (73) @ 3750	120 (88) @ 3500	120 (88) @ 3500	150 (110) @ 4000	150 (110) @ 4000	181 (133) @ 3750	
	Maximum torque lb/ft (Nm)	87 (118) @ 2750	151 (205) @1500	170 (230) @1750	170 (230) @1750	210 (285) @1750	243 (330) @1900	243 (330) @1900	187 (254) @ 1750	221 (300) @ 1750	221 (300) @ 1750	273 (370) @ 2000	273 (370) @ 2000	295 (400) @ 2000	
	5 speed manual	●	●						●						
	6 speed manual			●		●	●	●		●		●	●	●	●
6 speed automatic				●						●		●	●	●	
BRAKES	Front and rear discs	●	●	●	●	●	●	●	●	●	●	●	●	●	
SUSPENSIONS AND TYRES	Front suspension	Pseudo MacPherson													
	Rear suspension	De-formable Crossmember													
	Size - 15" wheels	195/65R15H													
	Size - 16" wheels	205/55R16V													
	Size - 17" wheels	225/45R17V													
	Size - 18" wheels	225/40R18W													
	Size - 19" wheels	235/35R19 91Y													
FUEL TANK	Capacity (litres)	53													
FUEL CONSUMPTION, EMISSIONS and PERFORMANCE (driver only)	15/16" wheels	Maximum speed (mph)	107	117	129	128				116	122	122			
		Acceleration 0-62 mph driver only (sec)	13.3	11.1	9.6	9.1				11.3	9.7	9.5			
		Urban drive cycle MPG (litres/100km)	44.8 (6.3)	54.3 (5.2) ■	49.6 (5.7)	50.4 (5.6)				65.7 (4.3)	80.7 (3.5) 78.5 (3.6)**	70.6 (4.0)			
		Extra Urban drive cycle MPG (litres/100km)	67.3 (4.2)	83.1 (3.4) ■	74.3 (3.8)	70.6 (4.0)				88.3 (3.2)	97.4 (2.9) 94.2 (3)**	85.6 (3.3)			
		Combined drive cycle MPG (litres/100km)	56.5 (5.0)	70.6 (4.0) ■	62.8 (4.5)	62.8 (4.5)				78.5 (3.6)	91.1 (3.1) 88.3 (3.2)**	80.7 (3.5)			
		Regulated Emission Standard	Euro 6	Euro 6	Euro 6	Euro 6				Euro 6	Euro 6	Euro 6			
		Carbon Dioxide (CO2) emissions (g/km)	114	95	104	106				94	82 84**	92			
	17/18" wheels	Maximum speed (mph)		117	125	124	146	155	155	112	117	118	132	131	137
		Acceleration 0-62 mph driver only (sec)		11.8	10.3	9.8	7.5	6.2	6.0	12.2	10.3	10.2	8.9	8.6	8.4
		Urban drive cycle MPG (litres/100km)		48.7 (5.8)	48.7 (5.8)	47.9 (5.9)	38.2 (7.4)	34.9 (8.1)	34.9 (8.1)	64.2 (4.4)	64.2 (4.4)	67.3 (4.2)	61.4 (4.6)	60.1 (4.7)	60.1 (4.7)
		Extra Urban drive cycle MPG (litres/100km)		70.6 (4)	70.6 (4.0)	65.7 (4.3)	61.4 (4.6)	57.6 (4.9)	57.6 (4.9)	88.3 (3.2)	83.1 (3.4)	80.7 (3.5)	80.7 (3.5)	78.5 (3.6)	80.7 (3.5)
		Combined drive cycle MPG (litres/100km)		61.4 (4.6)	61.4 (4.6)	57.6 (4.9)	50.4 (5.6)	47.1 (6.0)	47.1 (6.0)	76.3 (3.7)	74.3 (3.8)	74.3 (3.8)	72.4 (3.9)	70.6 (4.0)	70.6 (4)
		Regulated Emission Standard		Euro 6	Euro 6	Euro 6	Euro 6	Euro 6	Euro 6	Euro 6	Euro 6	Euro 6	Euro 6	Euro 6	Euro 6
		Carbon Dioxide (CO2) emissions (g/km)		107	107	112	130	139	139	96	98	98	102	105	103
VEHICLE WEIGHT INFORMATION (KG)	Gross vehicle weight	1645	1720	1750	1770	1790	1790	1790	1780	1805	1820	1870	1900	1920	
	Mass in service	1235	1345	1370	1380	1415	1395	1395	1400	1430	1440	1490	1535	1540	
	Kerb weight	1075	1080	1090	1150	1200	1205	1205	1160	1185	1200	1290	1310	1320	
	Gross train weight	2395	2920	3041	2970	3190	0	0	3074	3203	3120	3465	3398	3420	
	Maximum braked trailer weight	750	1200	1300	1200	1400	0	0	1300	1400	1300	1600	1500	1500	
	Maximum tow ball weight	75	75	75	75	75	0	0	75	75	75	75	75	75	
	Turning circle (m)	5.20													
INSURANCE GROUPS	ACCESS	9E							16E						
	SPORTIUM		11E	14E	14E										
	ACTIVE		12E	14E	14E				16E	19E	19E				
	ALLURE		13E	15E	15E					21E	21E	25E	25E		
	GT LINE			15E	15E					21E	21E	26E	26E		
	GT					26E								29A	
GTI						34E	34E								

\*\*Allure 1.6 BlueHDI 120 S65 Manual is fitted with 16" "Diamond" alloy wheel



# TECHNICAL SPECIFICATION (Continued)

## External/Internal Dimensions (mm)

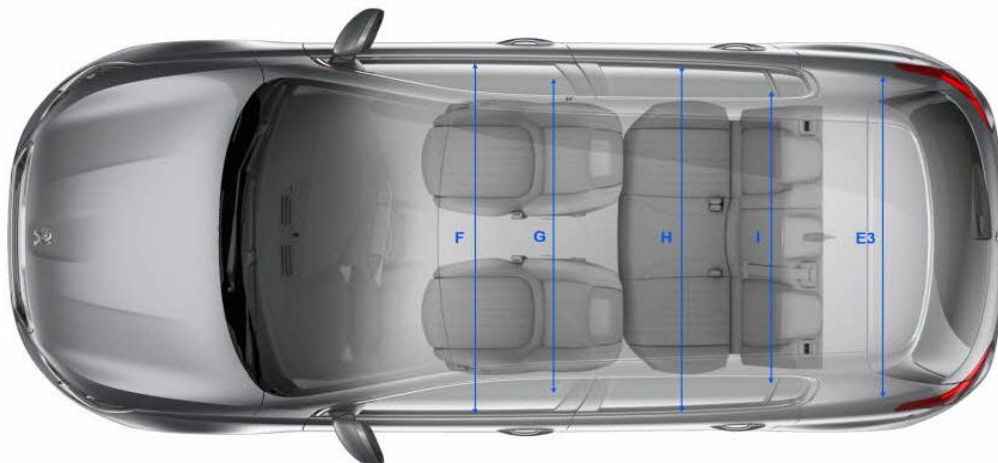
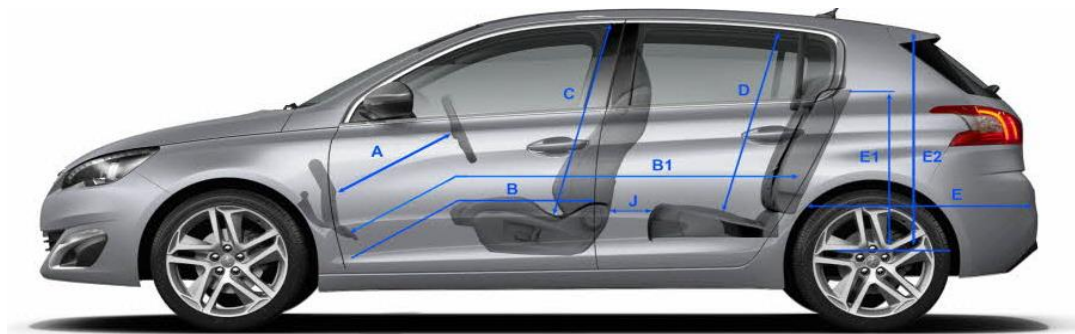
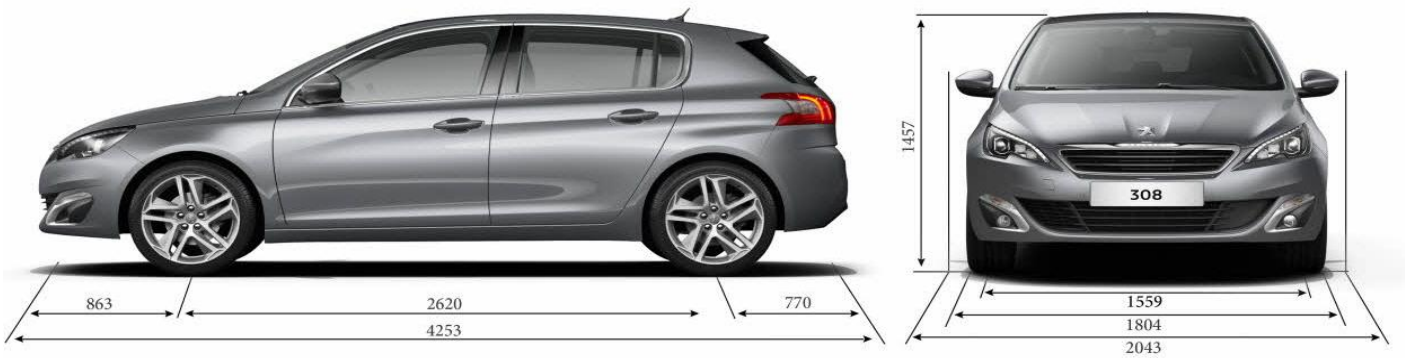

(mm)

A	673
B	866
B1	1688
C	895
D	874
E	807
E1	552
E2	774
E3	1099
F	1440
G	1395
H	1412
I	1365
J	95

# TECHNICAL SPECIFICATION (Continued)

## External/Internal Dimensions (mm)

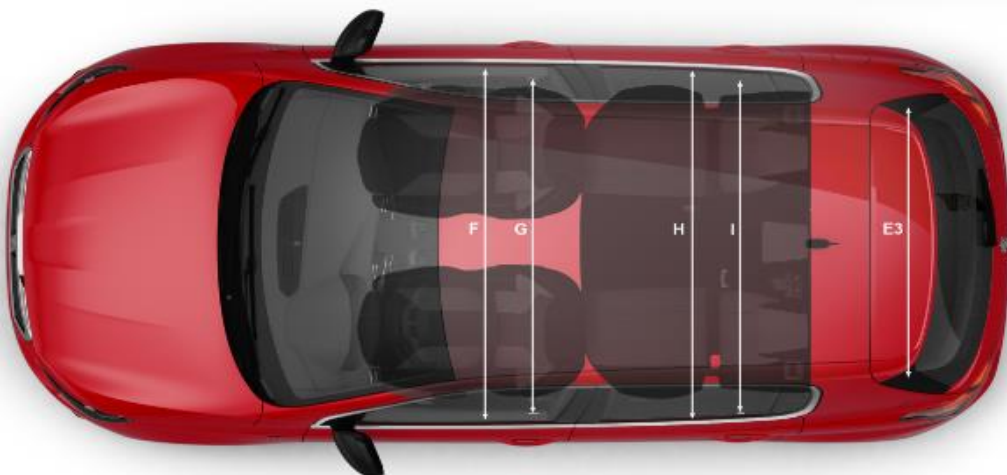
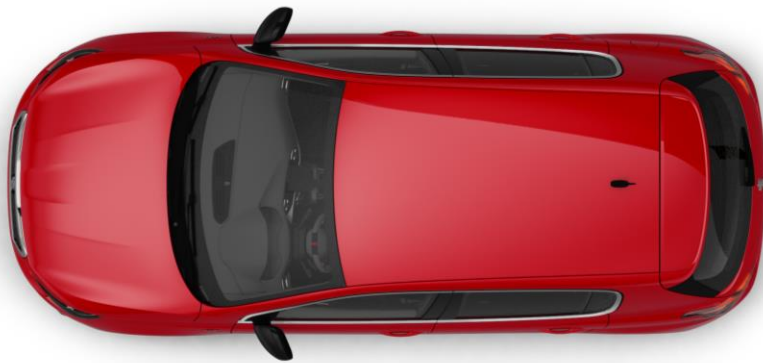
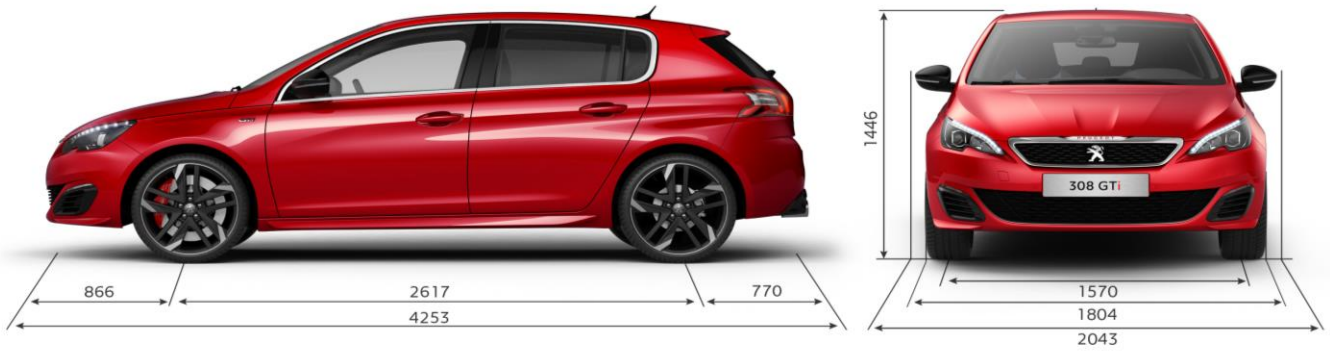

	(mm)
<b>A</b>	673
<b>B</b>	866
<b>B1</b>	1688
<b>C</b>	895
<b>D</b>	874
<b>E</b>	807
<b>E1</b>	552
<b>E2</b>	774
<b>E3</b>	1099
<b>F</b>	1440
<b>G</b>	1395
<b>H</b>	1412
<b>I</b>	1365
<b>J</b>	95

# TECHNICAL SPECIFICATION (Continued) /SAFETY

## Boot Dimensions (litres/dm<sup>3</sup>)





# FURTHER INFORMATION

## MANUFACTURERS RECOMMENDED RETAIL PRICE ON THE ROAD

The On the Road MRRP featured includes the following:

Tax band	CO2 (g/km)	First Year VED	Annual Tax	First Reg fee	Delivery Charge	VAT @ 20% on Delivery	Total OTR Costs
A	Up to 100	£0.00	£0.00	£55.00	£550.83	£110.17	<b>£716.00</b>
B	101-110	£0.00	£20.00	£55.00	£550.83	£110.17	<b>£716.00</b>
C	111-120	£0.00	£30.00	£55.00	£550.83	£110.17	<b>£716.00</b>
D	121-130	£0.00	£110.00	£55.00	£550.83	£110.17	<b>£716.00</b>
E	131-140	£130.00	£130.00	£55.00	£550.83	£110.17	<b>£846.00</b>
F	141-150	£145.00	£145.00	£55.00	£550.83	£110.17	<b>£861.00</b>
G	151-165	£185.00	£185.00	£55.00	£550.83	£110.17	<b>£901.00</b>
H	166-175	£300.00	£210.00	£55.00	£550.83	£110.17	<b>£1,016.00</b>
I	176-185	£355.00	£230.00	£55.00	£550.83	£110.17	<b>£1,071.00</b>
J	186-200	£500.00	£270.00	£55.00	£550.83	£110.17	<b>£1,216.00</b>
K	201-225	£650.00	£295.00	£55.00	£550.83	£110.17	<b>£1,366.00</b>
L	226-255	£885.00	£500.00	£55.00	£550.83	£110.17	<b>£1,601.00</b>
M	Over 255	£1,120.00	£515.00	£55.00	£550.83	£110.17	<b>£1,836.00</b>

VAT is calculated at 20%

VAT is not applicable to cars sold in the Channel Islands

## PEUGEOT 3 YEARS OF WARRANTY

All vehicles first registered in the UK and purchased from a UK Peugeot Dealer benefit from a Peugeot 2 year unlimited mileage manufacturer's warranty and a free optional additional 1 year of warranty provided by the Peugeot Dealer Network in the UK.

## PEUGEOT ASSISTANCE

All new Peugeots come with Peugeot Assistance, our breakdown assistance service.

Provided by the AA, Peugeot Assistance is available every minute of the day and night; 365 days of the year, for you and anyone else driving your Peugeot with your permission.

Full details are available at [www.peugeot.co.uk](http://www.peugeot.co.uk)

## TERMS AND CONDITIONS

Every endeavour has been made to ensure that the information, details and descriptions set out in this literature are correct, at the time of going to print.

It is our policy to continually improve our vehicles in every way. We reserve the right to modify our vehicles price, specification (including colour), equipment, accessories and characteristics or to discontinue any model, without notice, at any time.

To avoid any misunderstandings you are advised to check with your Peugeot Dealer the specification (including colour), equipment accessories and equipment relating to any Peugeot vehicle and the exact

Where a feature is described as an option in this publication it should be assumed that it is at extra cost unless specifically stated otherwise.

Issued by Sales and Marketing, Peugeot Motor Company PLC, Pinley House, Sunbeam Way, Coventry CV3 1ND.

For further information call Peugeot on 0845 200 1234 or visit our website at [www.peugeot.co.uk](http://www.peugeot.co.uk)



**PEUGEOT**