

CHALLENGER



MITSUBISHI
Spirited Cars for Spirited People



FACE THE CHALLENGE



BECAUSE THINGS ARE DIFFERENT OUT HERE

WHEN ADVENTURE BECKONS, THE CHALLENGER ANSWERS THE CALL WITH A 3.0 LITRE LPG COMPATIBLE 24 VALVE MULTI-POINT FUEL INJECTED V6 ENGINE. CHALLENGER FEATURES MITSUBISHI'S PROVEN 'EASY SELECT' PART TIME 4WD, WITH SYNCHRONISED FRONT FREE WHEELING DIFFERENTIAL FOR ON THE FLY 4WD ENGAGEMENT AND A HYBRID LIMITED SLIP REAR DIFFERENTIAL SO YOU CAN REACH YOUR FAVOURITE SPOT WITH EASE. CHALLENGER LS COMES STANDARD WITH THE CONVENIENCE OF THE 'SMART LOGIC' INVECS II 4 SPEED AUTOMATIC, WHILST CHALLENGER HAS THE SMOOTH SHIFTING 5 SPEED MANUAL STANDARD OR THE OPTIONAL INVECS II 4 SPEED AUTOMATIC.



ANOTHER WEEKEND... ANOTHER CHALLENGE

CHALLENGER IS EQUALLY AT HOME IN THE BUSH OR THE CITY AND YOU WILL ALWAYS ARRIVE IN STYLE, COMFORT AND WITH THE REASSURANCE OF MITSUBISHI'S ADVANCED SAFETY SYSTEMS. DRIVER AND PASSENGER SRS AIRBAGS, AND ABS BRAKES WITH ELECTRONIC BRAKE FORCE DISTRIBUTION (EBD) ARE STANDARD ACROSS THE RANGE TO GIVE YOU OPTIMUM BRAKING CONTROL. THE CONVENIENCE OF POWER STEERING, POWER WINDOWS AND THE STANDARD CRUISE CONTROL ENSURES A MORE RELAXING DRIVING EXPERIENCE ON THE OPEN ROAD.



CHALLENGER & CHALLENGER LS

THE RHYTHM OF THE ROAD

Slip into driving mode while pumping out the music on the security coded 4 speaker AM/FM radio CD player with electric antenna and half mast height adjuster. Challenger LS takes refinement to the next level with an in-dash 6 CD stacker and 6 speaker sound.



HANDS ON CONTROL

Choose from smooth shifting 5 speed manual transmission or the INVECS II 'Smart Logic' 4 speed automatic transmission, which comes standard on Challenger LS. Both models also offer 'Easy Select' part time 4WD for 'on the fly' switching between 2WD and 4WD up to 100kph.

FORM AND FUNCTION

Sleek and stylish, the rear spoiler on Challenger LS not only looks great but also helps keep the rear window clear of dust when you are exploring those far away places.



FINGERTIP CONVENIENCE
Power windows and side mirrors are easily controlled from the driver's side panel which features woodprint on Challenger LS and a titanium look on Challenger.



THE FEEL OF LEATHER

The Challenger LS features luxurious leather seating surfaces, dimple leather covered steering wheel, gear shifter and handbrake lever with silver stitching.



COMFORT ZONE

Challenger boasts comfortable new knit style upholstery in rear moulded bench seats that boast a split-fold and tumble forward function, for versatile passenger and cargo carrying options.



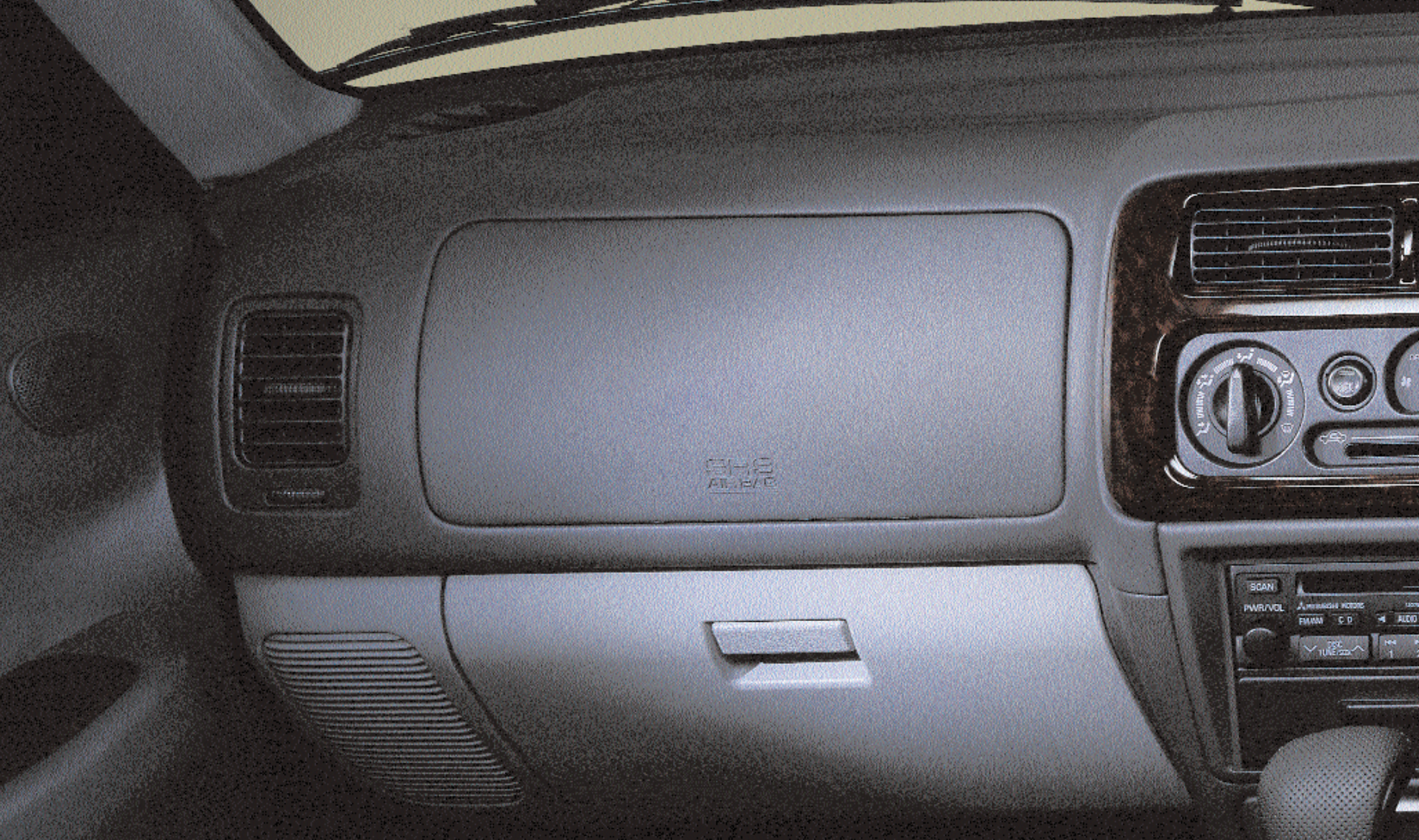

THE ONLY LUXURY FOR MILES AROUND

THE THRILL OF OFF ROAD ADVENTURE IS EQUALLY MATCHED BY THE ON ROAD COMFORT, LUXURY AND SAFETY OF CHALLENGER'S CABIN. THE TILT ADJUSTABLE STEERING COLUMN ENABLES YOU TO SELECT YOUR PREFERRED POSITION TO HELP REDUCE DRIVER FATIGUE. AIR CONDITIONING, CRUISE CONTROL AND POWER STEERING MAKE THE MILES PASS WITH EASE, WHILE THE DRIVER AND PASSENGER AIRBAGS PROVIDE EXTRA PEACE OF MIND. THE LUXURY OF CHALLENGER LS IS FURTHER ENHANCED BY THE DIMPLE LEATHER STEERING WHEEL, GEAR SHIFTER, HANDBRAKE LEVER AND SUMPTUOUS LEATHER SEATING SURFACES.

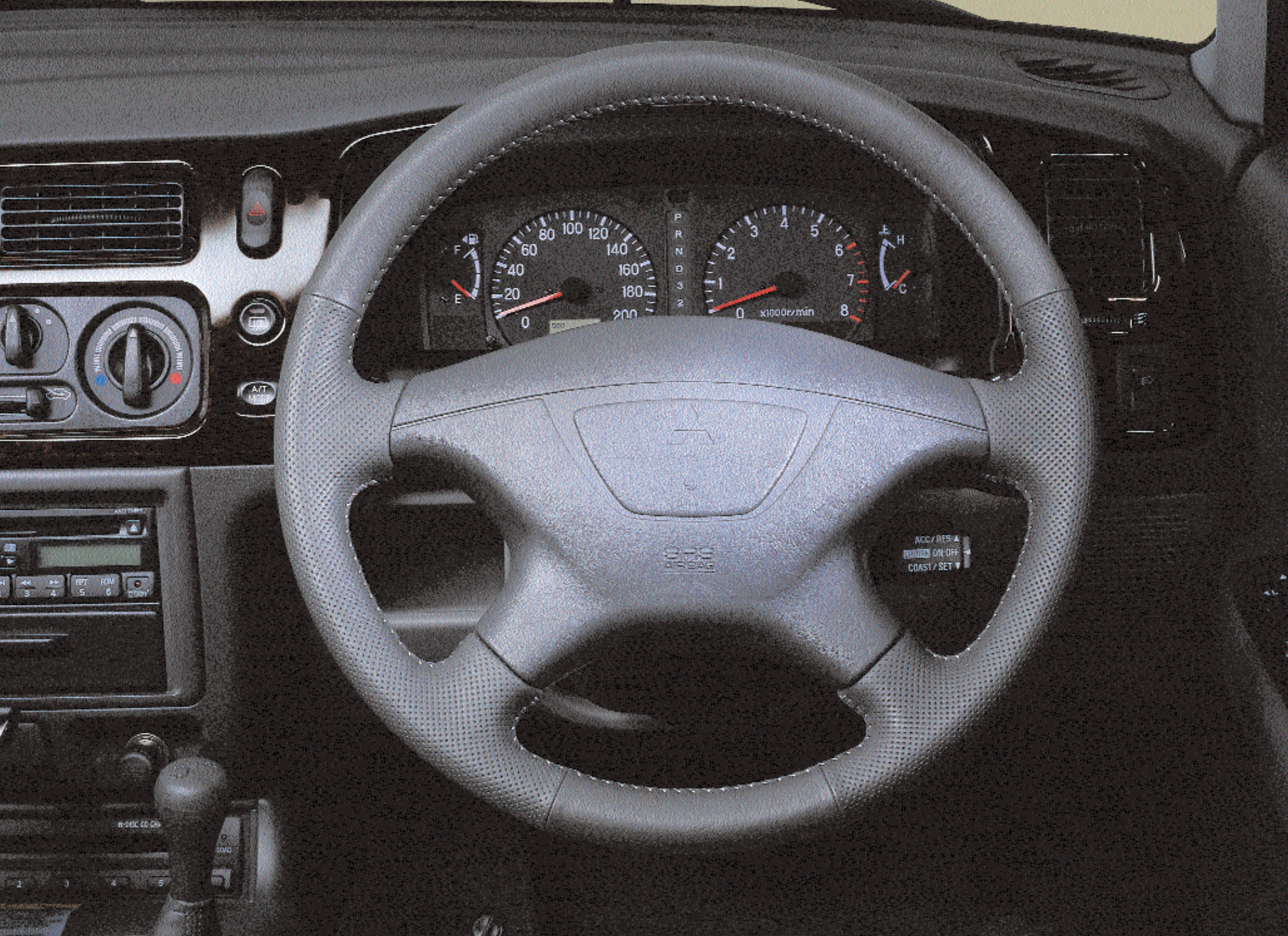

SRS
AIRBAG

ACC/RES ▲
POWER ON-OFF
COAST/SET ▼



CHALLENGER

It's in the detail that Challenger comes into its own, with ABS brakes and EBD, dual SRS airbags, height adjustable seatbelts, comfortable knit style seat trim and the convenience of remote keyless entry. It also features a standard 4 speaker AM/FM radio with CD, 60:40 split fold seats that can also totally fold out of the way for cargo carrying flexibility.



16" alloy wheels with 8 spoke finish.



Easy to use air conditioning controls in contemporary titanium look instrument panel.



The ease and convenience of cruise control to make long distance driving a breeze.



Easy to read digital clock.

CHALLENGER LS

The luxurious LS is a 4WD that will appeal to the most discerning drivers. LS pampers you with a stylish leather steering wheel, gear shifter and handbrake, sumptuous leather seating surfaces and 6 CD stacker with 6 speakers. And, with unique finish alloy wheels, chrome door mirrors, handles and fully integrated fog lamps, side steps and a streamlined rear spoiler, LS reflects your desire for more.

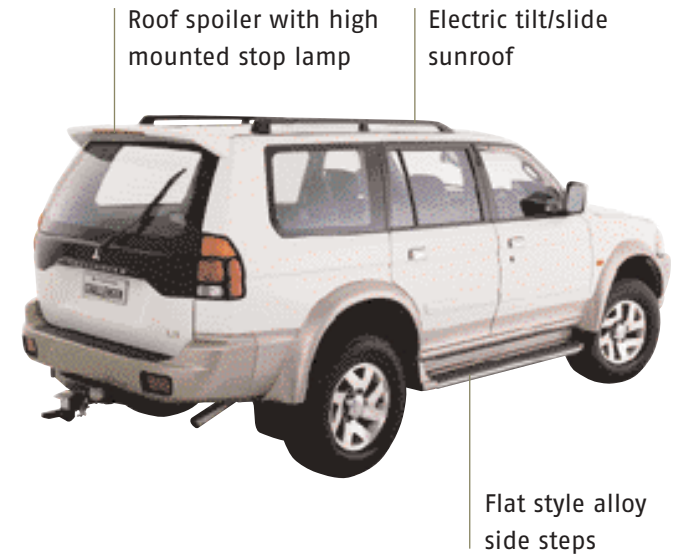

Bright, metallic 16" alloy wheels feature a unique 8 spoke finish.



AM/FM radio with single CD, in-dash 6 CD stacker and 6 speaker audio unit.

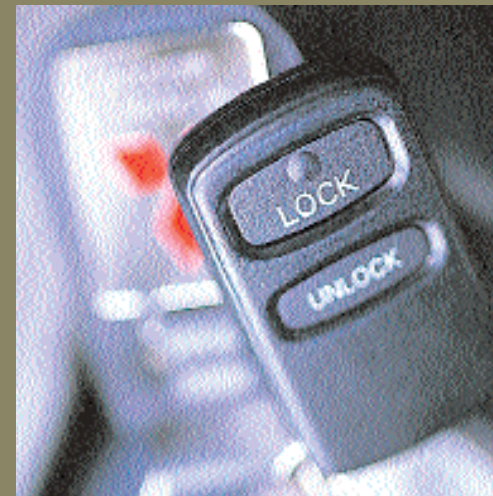

Central locking with remote keyless entry.



Rear cargo blind keeps your luggage out of sight.

ADVANCED DRIVER CONTROL

The 4 sensor, 4 channel Anti-lock Braking System (ABS) helps the driver maintain steering control, while Electronic Brakeforce Distribution (EBD) allows optimum straight line stopping control and minimum stopping distance regardless of the number of passengers or payload carried.

Vehicle without ABS and EBD –
all wheels lock causing skidding and steering control is lost.

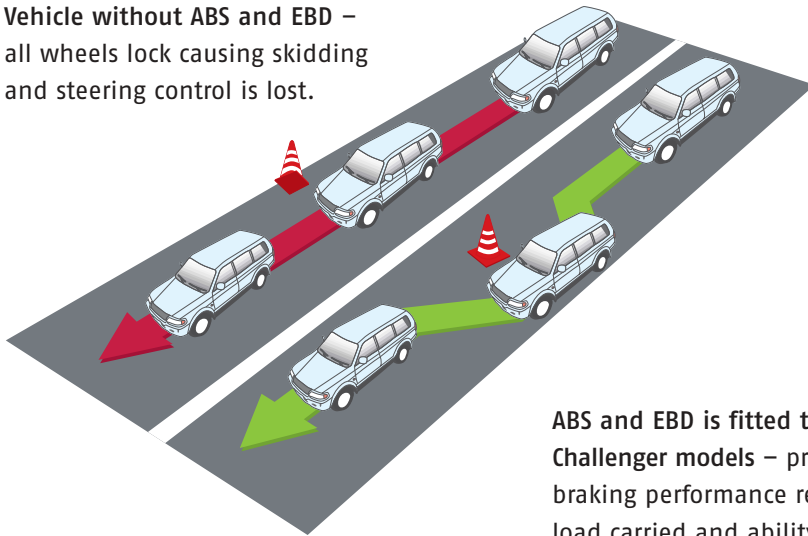

ABS and EBD is fitted to both Challenger models – providing greater braking performance regardless of load carried and ability to steer around vehicles or obstacles.

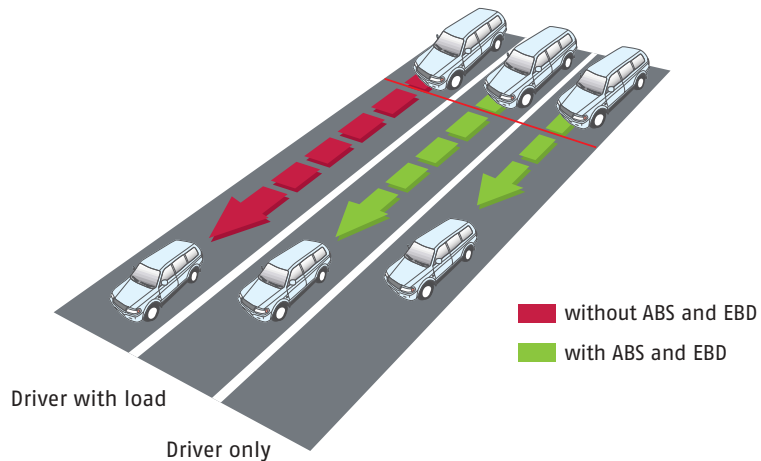

ALL TERRAIN MASTERY

Challenger's generous ground clearance combined with excellent approach, ramp breakover and departure angles allows you to tackle rough terrain with ease. An added advantage is the vehicle's ability to cross streams up to 500mm deep (at 5kph), taking you to even more remote off road adventures.

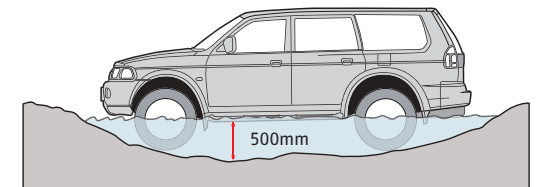
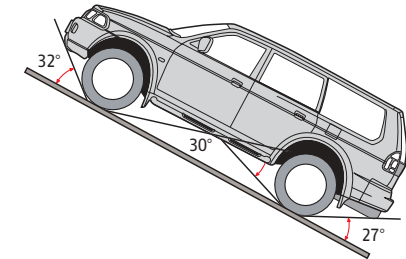

2H (4x2) high

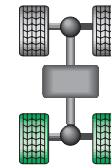

4H (4x4) high

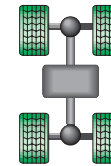

4L (4x4) low

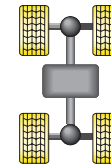

EASY SELECT 4WD

With 'Easy Select' Part time 4WD, Challenger offers you the convenience of switching between 2WD and 4WD without having to leave the vehicle. Challenger's synchronised front free wheeling differential allows 'on the fly' engagement of 4H up to speeds of 100 kph.

INTELLIGENT TRANSMISSION FOR SMOOTHER SHIFTING

To provide smoother shifting, the INVECS II 'Smart Logic' transmission system's on board computer learns and adapts to each driver's preferences by recording engine, tyre load and foot braking data. The control logic then adapts the gear shift timing to suit the driver's style, while minimising torque fluctuation for effortless acceleration and a more predictable ride.

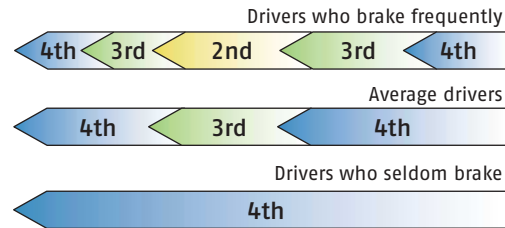

CRUISING POWER AND OFF ROAD TORQUE

The 3.0 litre, 24 valve multi-point fuel injected V6 engine delivers smooth power and efficient fuel economy. With 136kW of power Challenger has the muscle for easy overtaking on the highway, while the 265Nm of torque makes off road driving or towing a breeze.

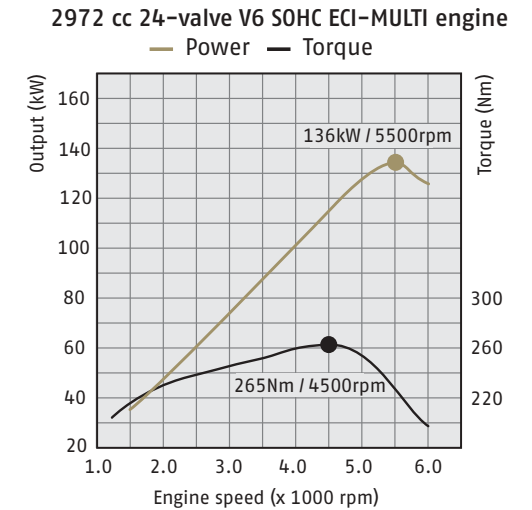

BEST OF BOTH WORLDS

Challenger's efficient design offers the best of both worlds by combining generous dimensions for comfortable cargo and passenger transport with easy manoeuvrability and handling around town or off road.

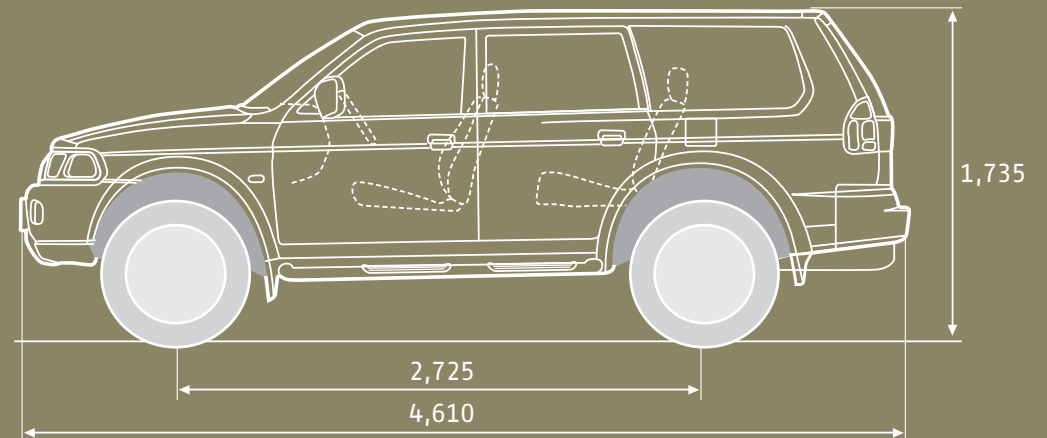
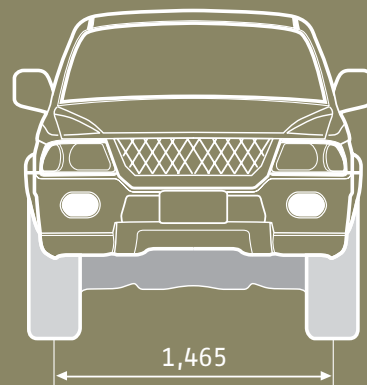

COLOUR RANGE



Deep Blue Mica



Green Mica



Medium Red Mica



Beige Metallic



White Solid



Black Mica



Cool Silver Metallic



White Pearl



Deep Blue Mica / Beige Metallic



Green Mica / Beige Metallic



Medium Red Mica / Medium Grey Mica



White Solid / Beige Metallic



Black Mica / Beige Metallic



Cool Silver Metallic / Medium Grey Mica

PAINT & TRIM COMBINATIONS

	CHALLENGER Luxury Cloth		CHALLENGER LS Leather	
	Warm	Cool	Warm	Cool
MONOTONE				
Deep Blue Mica	–	•	–	–
Cool Silver Metallic	–	•	–	•
Green Mica	•	–	–	–
Medium Red Mica	•	–	–	–
Beige Metallic	•	–	–	–
White Solid	–	•	–	–
Black Mica	–	•	–	•
White Pearl	–	–	•	–

	CHALLENGER Luxury Cloth		CHALLENGER LS Leather	
	Warm	Cool	Warm	Cool
2-TONE				
Deep Blue Mica / Beige Metallic	–	•	–	•
Green Mica / Beige Metallic	•	–	•	–
Medium Red Mica / Medium Grey Mica	•	–	•	–
White Solid / Beige Metallic	–	•	–	•
Cool Silver Metallic / Medium Grey Mica	–	•	–	•
Black Mica / Beige Metallic	•	–	•	–

Warm - Beige Interior trim. Cool - Grey Interior trim

CHALLENGER SPECIFICATIONS

ENGINE

Type	3.0L V6 SOHC 24 valve MPI
Bore x stroke	91.1mm x 76mm
Capacity	2972cm ³
Compression ratio	9.0:1
Fuel system	ECl multi fuel inject – LPG Compatible
Maximum power	136kW @ 5500rpm
Maximum torque	265Nm @ 4500rpm

ELECTRICAL SYSTEM

Battery	75D23R (520CCA/118RC)
Alternator	12V-85A

TRANSMISSION

Type	5 speed Manual or 4 speed Automatic with INVECS II 'Smart Logic'
------	--

RATIOS

	MANUAL	AUTOMATIC
First	3.918	2.842
Second	2.261	1.495
Third	1.395	1.000
Fourth	1.000	0.731
Fifth	0.829	-
Reverse	3.925	2.720

TRANSFER RATIO

High	1.000	1.000
Low	1.925	1.900

FINAL DRIVE

	MANUAL	AUTOMATIC
Final Gear Ratio	4.636	4.636

CLUTCH

Manual	Single dry plate with diaphragm spring, hydraulic action
Automatic	3 element torque converter with lock up

DRIVE TRANSFER SYSTEM

Type	"Easy Select" Part Time 4WD Auto front free-wheeling differential with synchromesh
------	---

BRAKES

Front	Ventilated discs
Rear	Solid discs
	Anti-lock brakes (ABS) with Electronic Brake Force Distribution (EBD)

SUSPENSION

Front	Independent – double wishbone, torsion bar and stabiliser
Rear	Rigid 3 link, coil springs and stabiliser

STEERING

Type	Power assisted recirculating ball and nut
------	---

WHEELS

Type	16" x 7JJ Alloy
------	-----------------

TYRES*

Size	16" 255/70R16-109S
------	--------------------

* The tyres fitted to Challenger as standard equipment are designed primarily for use on sealed roads. If your Challenger is to be driven primarily on unsealed roads, please consult your Mitsubishi dealer for advice on a suitable tyre selection

EXTERIOR DIMENSIONS (MM)	MANUAL	AUTO	LS AUTO
Overall height	1735	1735	1780
Overall length	4610	4610	4610
Overall width	1775	1775	1775
Track – front	1465	1465	1465
Track – rear	1480	1480	1480
Wheelbase	2725	2725	2725
Turning Circle – kerb to kerb	11.8m	11.8m	11.8m
GROUND CLEARANCE			
Ground clearance – unladen (mm)	215	215	215
Fording depth (mm)	500	500	500
Approach angle	32°	32°	32°
Departure angle	27°	27°	27°
Ramp angle	30°	30°	30°
LOAD AREA (MM)			
Length – seat down	1805	1805	1805
Width	1360	1360	1360
Height	885	885	885
Width at wheel arches	960	960	960

CAPACITIES (KG)	MANUAL	AUTO	LS AUTO
Gross vehicle mass	2430	2430	2430
Kerb mass	1840	1850	1870
Payload**	590	580	560
Gross combination mass	4310	4540	4540
Maximum front axle load	1200	1200	1200
Maximum rear axle load	1600	1600	1600
Seating Capacity	5	5	5
** Payload includes occupants, fuel and fitted options (if any). The weight of these must be deducted from Payload to determine actual load carrying capacity. Front and/or Rear Axle Loads must not be exceeded.			
MAXIMUM TOWING CAPACITY* (KG)			
With trailer brakes	2270	2270	2270
Without trailer brakes	750	750	750
Towball download	227	227	227
* Subject to State regulations and towbar designs. For further information, please refer to the Challenger Owner's Manual.			
FUEL TANK CAPACITY			
Litres	74	74	74
FUEL CONSUMPTION ADR81/01 (LITRES PER 100KM)			
Combined	13.4	11.9	11.9
These figures are obtained from controlled laboratory tests conducted by Mitsubishi Motors to Australian Standard ADR81/01 and are provided to assist you in comparing the fuel consumption of Challenger with other vehicles. The actual fuel consumption you achieve will depend, however, on many factors, including your driving habits, the prevailing conditions and your vehicles equipment, condition and use.			

CHALLENGER SPECIFICATIONS

MECHANICAL

Power Train	MANUAL	AUTO	LS AUTO
3.0L V6, SOHC, MPI, 24 valve – LPG compatible	•	•	•
5 speed manual transmission	•	–	–
4 speed automatic transmission with INVECS II 'Smart Logic'	–	•	•

Mechanical

Part Time 4WD with 'Easy Select'	•	•	•
Synchronised auto front free wheeling differential	•	•	•
Limited Slip Differential (rear)	•	•	•
Power steering	•	•	•
Power assisted 4 wheel disc brakes	•	•	•
Front – ventilated discs	•	•	•
Rear – solid discs	•	•	•
Anti-lock Braking System (ABS) with Electronic Brakeforce Distribution (EBD)	•	•	•
Engine Immobiliser	•	•	•

Suspension

Front – Independent: double wishbone, torsion bar and stabiliser	•	•	•
Rear – Rigid: 3-link, coil springs and stabiliser	•	•	•

EXTERIOR

Wheels & Tyres

16" x 7JJ eight spoke alloy wheels. 255/70R16 109S tyres (HT)	•	•	–
16" x 7JJ eight spoke alloy wheels (chrome finish). 255/70R16 109S tyres (HT)	–	–	•
Matching alloy spare wheel	•	•	•

EXTERIOR CONTINUED

Exterior Styling	MANUAL	AUTO	LS AUTO
Engine and transfer case protector plates	•	•	•
Front skid plate	•	•	•
Fog lamps (front) – projector type	–	–	•
Windscreen wiper/washer with variable intermittent	•	•	•
Tailgate wiper/washer with fixed intermittent	•	•	•
Roof spoiler – body colour (with HMSL)	–	–	•
Black roof rails	–	–	•
Roof racks	◆	◆	–
Roof rail cross bars	–	–	◆
Body colour side mouldings	•	•	•
Door mirrors – Black (electrically controlled)	•	•	–
Door mirrors – Chrome (electrically controlled)	–	–	•
Black door handles and tailgate handle	•	•	–
Chrome door handles and tailgate handle	–	–	•
Two Tone paint	○	○	○
Tube-style side steps (black)	•	•	–
Flat-type side steps – with body coloured support	–	–	•
Mud flaps – front and rear	•	•	•
Towing hooks (front and rear)	•	•	•

• standard – not available ○ optional ◆ dealer fitted accessory

INTERIOR

Audio	MANUAL	AUTO	LS AUTO
Security coded AM/FM Radio/CD player	•	•	•
In-dash 6 CD Stacker	◆	◆	•
Power antenna with half-mast stop function	•	•	•
No. of Speakers	4	4	6
Interior Styling			
Titanium look instrument panel	•	•	–
Woodgrain look instrument panel	–	–	•
Titanium look power window switch panel surrounds	•	•	–
Wood grain look power window switch surrounds (front only)	–	–	•
4 spoke urethane steering wheel	•	•	–
4 spoke dimple leather wrapped steering wheel with silver stitching	–	–	•
Dimple leather covered gear shift lever with silver stitching	–	–	•
Dimple leather covered handbrake lever	–	–	•

INTERIOR

Safety	MANUAL	AUTO	LS AUTO
Driver and front passenger SRS airbags	•	•	•
Anti-lock Braking System (ABS) with Electronic Brakeforce Distribution (EBD)	•	•	•
Side door impact beams	•	•	•
Day/night rear view mirror	•	•	•
Child proof rear door locks	•	•	•
Child restraint anchor points	3	3	3
Security			
Central door locking (incl. tailgate)	•	•	•
Cabin illumination on unlock	•	•	•
Automatic cabin illumination on key removal	•	•	•
Anti-theft encrypted immobilisation	•	•	•
Flashing security lamp in security coded radio	•	•	•

• standard – not available ◊ optional ◆ dealer fitted accessory

CHALLENGER SPECIFICATIONS

INTERIOR CONTINUED

Comfort & Convenience	MANUAL	AUTO	LS AUTO
Air conditioning	•	•	•
Central door locking with remote keyless entry	•	•	•
Power windows front and rear with driver's auto-down function	•	•	•
Cruise control	•	•	•
Electric sunroof – tilt and slide function	–	–	•
Electric door mirrors	•	•	•
Tilt adjustable steering column	•	•	•
Overhead console – large type (with sunglasses pockets)	•	•	–
Interior lamp with time delay and front map lamps	•	•	•
Digital clock	•	•	•
Door mounted hazard lamps – front	•	•	•
Ignition key illumination	•	•	•
Variable instrument lighting dimmer	•	•	•
In-dash indicator for automatic transmission position	–	•	•
Headlamps “ON” – audible warning buzzer	•	•	•
Warning lamps include 4WD indicator, door ajar and low fuel	•	•	•
High rise centre console armrest	•	•	•
Accessory socket in console	•	•	•
Remote fuel filler door release	•	•	•
Passenger assist handles	3	3	3
Passenger grab handles	4	4	4
Vanity mirror with lid	•	•	–
Vanity mirror with lid and lamp (driver and passenger)	–	–	•
Rear window demister	•	•	•
Accessory socket in rear quarter trim	•	•	•
Convenience lamp in luggage area	•	•	•

INTERIOR CONTINUED

Seating	MANUAL	AUTO	LS AUTO
Front seats – reclining bucket type	•	•	•
Luxury cloth seat trim	•	•	–
Leather seating surfaces	–	–	•
Rear seats – moulded bench type with split fold and tumble forward fold function	•	•	•
Driver's seat height adjuster	•	•	•
Front seat belts with adjustable shoulder anchor	•	•	•
Height adjustable front seat head restraints	•	•	•
Height adjustable rear seat outboard head restraints	•	•	•

INTERIOR CONTINUED

Storage	MANUAL	AUTO	LS AUTO
Cup holders	2	2	2
Cup holders in folding rear arm rest	2	2	2
Storage compartment in dash with lid	•	•	•
Storage compartment in lower dash console	•	•	–
Front seat back map pocket	•	•	•
Front door trim map pockets	•	•	•
Centre console storage compartment	•	•	•
Coat Hooks	2	2	2
Fully trimmed cargo area and tailgate	•	•	•
Luggage area compartment cover rail	•	•	•
Luggage area compartment cover (retractable)	◆	◆	•
Luggage net hooks	•	•	•
Luggage net	◆	◆	◆
Luggage area storage compartments (in quarter trims)	2	2	2
Luggage area floor storage boxes	2	2	2
Luggage tie-down hooks	4	4	4
OPTIONS			
Two-tone Paint	○	○	○

• standard – not available ○ optional ◆ dealer fitted accessory

CHALLENGER ACCESSORIES

Mitsubishi is committed to complete customer satisfaction. Therefore, when Genuine Mitsubishi Accessories are fitted to your new vehicle at time of delivery, they are covered by the Mitsubishi New Vehicle 3 year/100,000km Warranty. When they are fitted after you have purchased your new vehicle they are covered for the remainder of the new vehicle warranty or for 12 months/20,000km, whichever is the longer. In the case of Diamond Spectrum Accessories, the Warranty is 12 months/20,000km.

Please check with your Mitsubishi Dealer for specific model applications.



Bonnet Protector



Headlight Protector



Rear Window Dust Guard



Weathershields



Roof racks



Towbar



CD Changer



Rear Cargo Barrier



Rear Cargo Blind



Rear Cargo Liner



Rear Cargo Mat



Carpet Mats



Cargo Net

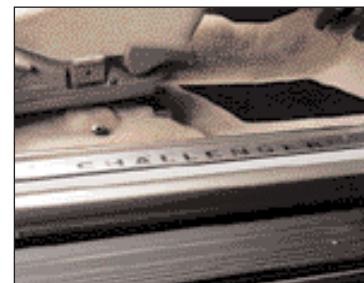

Scuff Plates*



Locking Wheel Nuts*

* Diamond Spectrum Accessory | Pictures shown are for illustration purposes only and may not be product specific.

MITSUBISHI RANGE



MAGNA

The new look 2003 Magna features an impressive line up of standard features including driver, front passenger and side airbags, six-way adjustable power driver's seat, cruise control, climate control air conditioning and power windows. In addition, VR-X and VR boast new street smart styling including new seat trims, sports style instruments and a leather wrapped steering wheel, combined with the powerful performance of the newly tuned engine. The Magna line up includes ES, LS, VR, VR-X. Wagon variations in ES, LS and VR.



MAGNA AWD & VR AWD

While echoing the new global styling of the Magna range, these models boast Mitsubishi's technically advanced QuadTec™ AWD system. This refined AWD system distributes torque equally to all four wheels, especially in low traction conditions, to deliver superior road holding, outstanding stability and improved cornering control. Magna AWD and VR AWD are also fitted with high performance brakes in conjunction with ABS and EBD to provide superior stopping power on all surfaces.



VERADA

The distinctive looking, new 2003 Verada continues to set the benchmark in quality and refinement. Verada comes with all the new features standard on Magna, plus a ten-way adjustable power driver's seat, traction control and a premium audio system with 6 disc, in-dash CD changer. Verada models include Ei (sedan and wagon), Xi, GTVi and AWD which boasts outstanding stability, superior roadholding and improved cornering control for safer, more spirited driving.



LANCER

The new CH Lancer takes Mitsubishi's rally bred technology to the city streets in a distinct new look with a host of great features. The sporty VRX, with its bold rear spoiler and black interior, boasts 16" alloy wheels, a new strut brace for greater handling and 4 speed automatic transmission with 'SPORTS MODE' sequential gear shifting for hands on control from the new EVO type "Steer-matic" 3-spoke steering wheel.



MIRAGE

This compact, 3 door hatch features a zippy 1.5 litre 12 valve, multi-point fuel injected engine. Available as a 5 speed manual or with INVECS II 'Smart Logic' 4 speed automatic transmission. Features include SRS driver's airbag, power steering, ample room and plenty of style.



PAJERO

An undisputed off road rally champion, Pajero delivers powerful performance, renowned reliability, generous interior space and superior safety. Powered by a 3.8 litre V6 24 valve fuel injected engine, with the option of a 3.2 litre intercooled turbo direct injection diesel (Di-D), Pajero boasts a maximum towing capacity of 2500kg.



OUTLANDER

A compact, 4WD offering a unique combination of sports styling, flexible interior space, ride comfort and unprecedented safety. Seats five people in comfort and features a range of cargo carrying options, while the automatic transmission boasts 'SPORTS MODE' sequential gear shifting.



TRITON

A tough, hard working ute available in a range of powerful engine capacities and fuel types. The range of Triton models includes Cab Chassis, Double Cab and Club Cab.



EXPRESS

One of Australia's favourite light commercial vans, Express features a choice of petrol engines that are LPG compatible. The range of body types includes Short Wheel Base (SWB), Medium Wheel Base (MWB), Window Van (SWB) and Walk-Thru model (MWB).



NIMBUS

A stylish, award winning people mover. Nimbus comfortably seats seven adults with a variety of different seating and storage configurations. Powered by a 2.4 litre SOHC 16 valve, electronic multi-point fuel injected engine.

Diamond Finance

Take the burden out of financing your new Mitsubishi vehicle with our competitive, reassuring and completely flexible range of finance products developed by Mitsubishi Motors Australia Ltd and St.George Motor Finance Limited.

Diamond Leasing

Our tailored fleet leasing services offer innovative, highly competitive features such as card purchasing, roadside assistance, specialist maintenance services, accident and claims management, optional insurance and more.

Diamond Road Side Assist

Peace of mind is guaranteed anywhere in Australia, 24 hours a day, 365 days a year with our fast, comprehensive, flexible roadside service offering assistance, repairs, towing and storage. Our Premium Roadside Assist clients also enjoy the added benefits of accommodation, medical and transport facilities.

Diamond Insurance

With the sound backing of Swann Insurance and Mitsubishi Motors Australia Ltd, Mitsubishi owners can choose between vehicle and personal protection solutions including motor vehicle, gapcover and loan protection insurance as well as a range of tailored warranty policies.

For more information on Diamond Products and Services contact your Mitsubishi Dealer.

Mitsubishi Motors Australia Ltd. offers a 3 year/100,000 kilometre New Vehicle Warranty and a 5 year Perforation Corrosion Warranty on Mitsubishi Challenger. Always consult your authorised Mitsubishi Dealer for the latest details on specifications, options, prices, availability and conditions on New Vehicle Warranty. All product illustrations and specifications referred to herein are correct at the time of publication approval. Subject to any applicable Federal, State or Territory laws or ordinances which may apply from time to time. Mitsubishi Motors Australia Ltd. reserves the right, without notice or obligation, to discontinue or make changes to designs, specifications, colours and materials of the options and products referred to herein at any time without incurring any liability to any purchaser thereof. ©Mitsubishi Motors Australia Limited ABN 53 007 870 395 SEP'03 MMAL1546



