



S3





A breathtaking drive awaits you.
Prepare yourself.

Power, acceleration and dynamic performance. Experience what will fascinate you in the Audi S3 day by day: its exclusivity, its charisma, its design. The same fascination, a different model: the Audi S3 Sportback. Enjoy it. Every single second.



**The warm-up: take a look.
Your desires are aroused.
Now step inside.**

Its athletic lines have already impressed you from afar. Curious, you move closer. The large 18-inch cast aluminium wheels and the low-slung body emphasise its sportiness. The roof edge spoiler, the wide sills and the distinctive front bumper with large air intakes under the Xenon plus headlights with LED daytime running lights do the rest. The aluminium-look exterior mirrors with integral indicators sparkle briefly in the sun. As indeed do your eyes. Choose your vehicle. Step inside.

00:00:00:00 00:00:00:00 00:00:00:00 00:00:00:00 00:00:00:00 00:00:00:00 00:00:00:00 00:00:00:00 00:00:00:00 00:00:00:00



Turbocharging. The power unfolds.
The excitement grows.

00:00:02.56

00:00:02:10 00:00:02:20 00:00:02:30 00:00:02:40 00:00:02:50 00:00:02:60 00:00:02:70 00:00:02:80 00:00:02:90 00:00:03:00



5.5 seconds*: 100 km/h.
110 km/h. Don't stop now!



00:00:05:10 00:00:05:20 00:00:05:30 00:00:05:40 00:00:05:50 00:00:05:60 00:00:05:70 00:00:05:80 00:00:05:90 00:00:06:00

00:00:05:70 S3

* S3 2.0 TFSI quattro with S tronic transmission; S3 Sportback: 5.6 seconds. Sportback: 5.6 seconds.



Into the straight.
Maximum concentration.

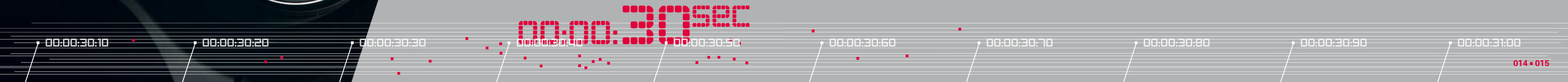



60 seconds: 2.0 TFSI*. 195 kW. 350 Nm.
Accelerate further.

00:00:00sec

00:00:59:10

00:00:59:20

00:00:59:30

00:00:59:40

00:00:59:50

00:00:59:60

00:00:59:70

00:00:59:80

00:00:59:90

00:00:60:00

* Fuel consumption and CO₂ emissions figures can be found on page 44.



Destination in sight. Slow down.
Brake pedal pressed.
17-inch brakes get to work.



00:01:30:10

00:01:30:20

00:01:30:30

00:01:30:40

00:01:30:50

00:01:30:60

00:01:30:70

00:01:30:80

00:01:30:90

00:01:31:00

00:01:30 min



Pulse dropping. You have arrived. Take a deep breath.

Leather sports steering wheel, 3-spoke design, flattened at the bottom*; gear knob with S3 emblem, gear lever gaiter and handbrake grip with contrasting seams; sports seats in Alcantara/leather in pearl silver/black*; door sill trim with S3 emblem; boomerang-shaped (for Audi S3) aluminium-look console* in the door.

* Optional.



00:02:30:10

00:02:30:20

00:02:30:30

00:02:30:40

00:02:30:50

00:02:30:60

00:02:30:70

00:02:30:80

00:02:30:90

00:02:31:00



Feel the space. **Feel freedom.**

The luggage compartment capacity of the S3 Sportback is 302 litres, increasing to 1,032 litres with the rear bench seat folded down. A practical through-loading facility. Plenty of room, plenty of flexibility. And a panorama sunroof that enables you to see right up to the sky.

00:02:45:10

00:02:45:20

00:02:45:30

00:02:45:40

00:02:45:50

00:02:45:60

00:02:45:70

00:02:45:80

00:02:45:90

00:02:46:00

Paints

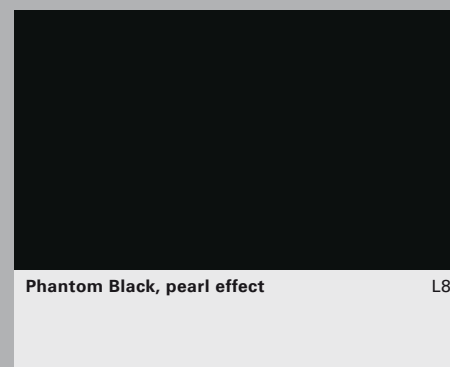
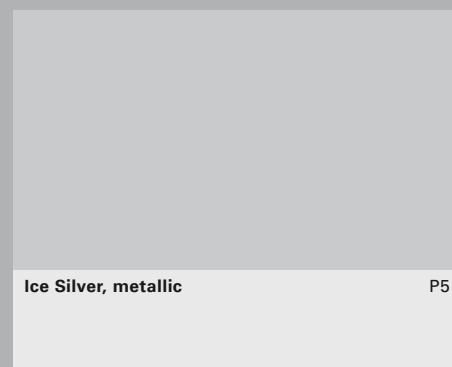
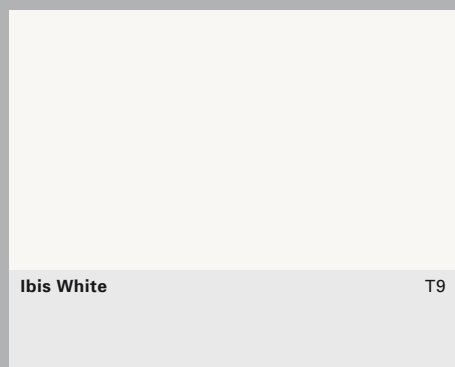
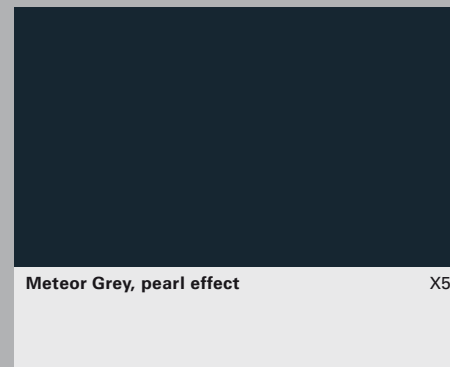
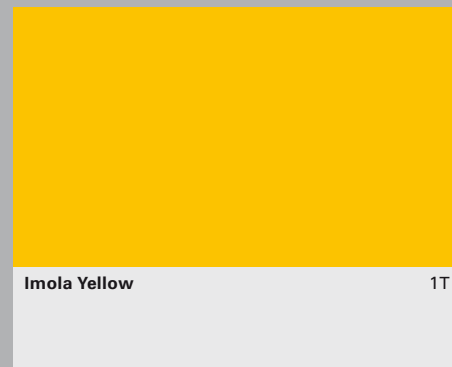
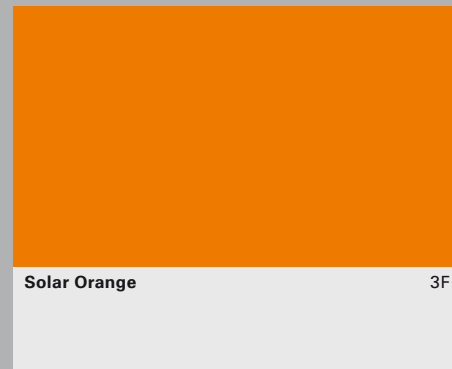
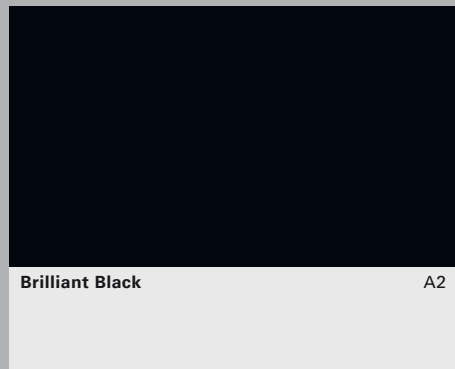

Please find out from your local Audi partner which equipment is standard and what optional equipment is available in your country.

Model	S3 2.0 TFSI quattro	S3 Sportback 2.0 TFSI quattro
-------	---------------------	-------------------------------

Engine type	4-cylinder in-line petrol engine with direct fuel injection and exhaust-gas turbo-charger	4-cylinder in-line petrol engine with direct fuel injection and exhaust-gas turbo-charger
Displacement in cc (valves per cylinder)	1984 (4)	1984 (4)
Max. output ¹ in kW at rpm	195/6000	195/6000
Max. torque in Nm at rpm	350/2500–5000	350/2500–5000

Power transmission/wheels

Type of drive	quattro® permanent all-wheel drive	quattro® permanent all-wheel drive
Transmission	6-speed manual transmission, all-synchromesh [6-speed S tronic]	6-speed manual transmission, all-synchromesh [6-speed S tronic]
Wheels	Cast aluminium wheels, 7.5 J x 18	Cast aluminium wheels, 7.5 J x 18
Tyres	225/40 R 18	225/40 R 18

Weights/capacities

Unladen weight ² in kg	1455	[1475]	1495	[1515]
Gross vehicle weight in kg	2015	[2035]	2055	[2075]
Roof load in kg	75		75	
Fuel tank capacity, approx. in l	60		60	

Performance/consumption³

Top speed in km/h	250 ⁴	[250 ⁴]	250 ⁴	[250 ⁴]	
Acceleration 0–100 km/h in s	5.7	[5.5]	5.8	[5.6]	
Fuel grade	SuperPlus unleaded 98 RON ⁵		SuperPlus unleaded 98 RON ⁵		
Fuel consumption ⁶ in l/100 km	urban	11.8	[11.1]	11.8	[11.2]
	extra-urban	6.6	[6.7]	6.7	[6.8]
	combined	8.5	[8.3]	8.5	[8.4]
CO ₂ emissions ⁶ in g/km	urban	275	[257]	275	[259]
	extra-urban	154	[156]	157	[158]
	combined	198	[193]	199	[195]
Emissions standard	EU 5		EU 5		

Notes

- ¹ The value stated was calculated using the specified measuring procedure (current version of Directive 80/1269/EEC).
- ² Weight of car, unladen, without driver (calculated in accordance with the current version of Directive 92/21/EEC). Optional equipment may increase the car's unladen weight and drag coefficient, whereupon the possible payload limit and the top speed will be reduced accordingly.
- ³ A vehicle's fuel consumption and CO₂ emissions do not just depend on how efficiently the vehicle uses the fuel, but are also influenced by driving behaviour and other non-technical factors. CO₂ is the greenhouse gas primarily responsible for global warming.
- ⁴ Regulated.
- ⁵ We recommend using SuperPlus unleaded (98 RON). If this is not available, use super unleaded (95 RON); power output will be slightly reduced.
- ⁶ The value stated were calculated using the specified measuring procedures. The figures do not refer to one individual vehicle and do not form part of any offer, but rather should be used purely for purpose of comparison between the different vehicle models.

Important note

Inspections are due as shown by the service display.

S3 dimensions

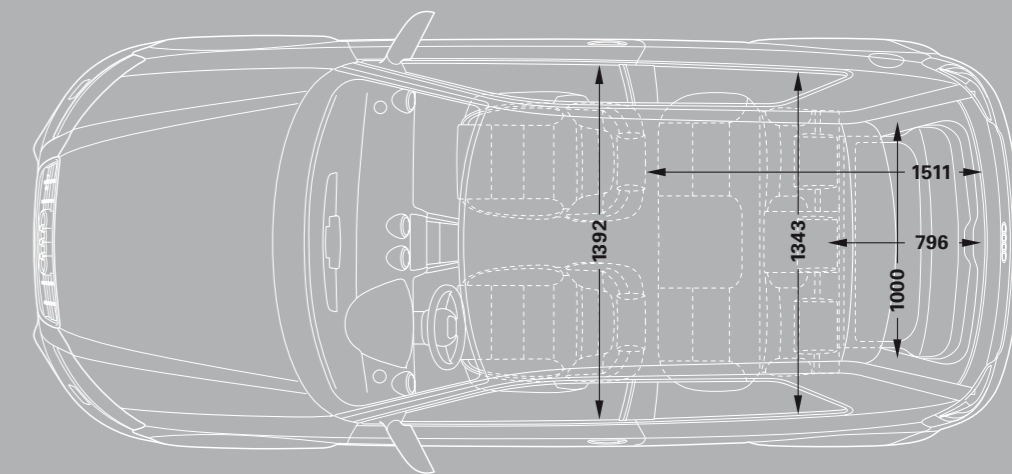
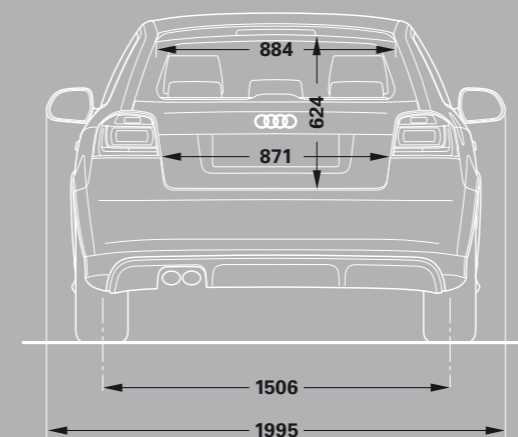
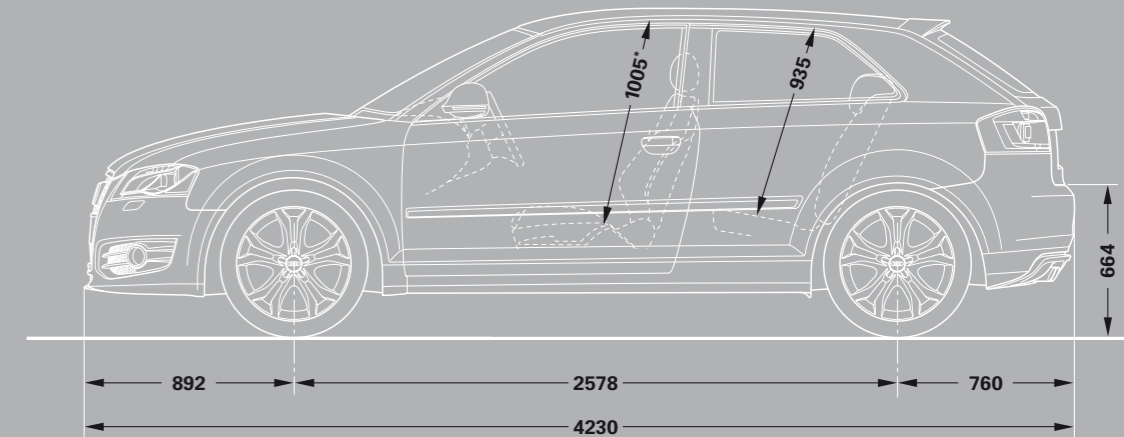
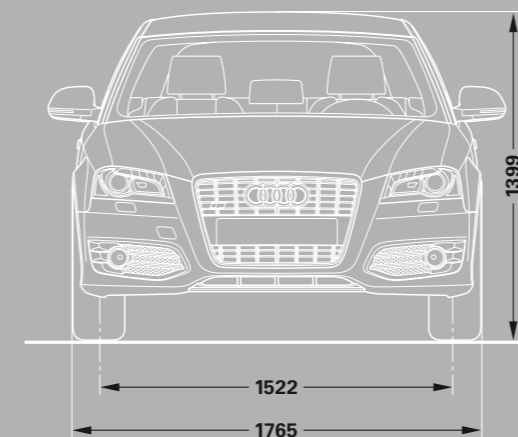

Dimensions in millimetres.

Dimensions were measured with vehicle at unladen weight, ground clearance measured with vehicle carrying its maximum load. Luggage compartment volume 281/1,011 l (measured by the VDA method using 200 x 100 x 50 mm blocks; second value with rear seat back folded down and vehicle loaded up to roof height). Turning circle approx 10.7 m

*Maximum headroom.

The models and equipment versions illustrated and described in this brochure and some services listed are not available in all countries. Some of the cars illustrated are equipped with optional equipment for which an extra charge is made. Details concerning the delivery specifications, appearance, performance, dimensions and weights, fuel consumption and running costs of the vehicle were correct to the best of our knowledge at the time of going to press. There may be some variations between the Australian vehicle specifications and those manufactured for other markets. Please speak to your Audi Dealer should you have any questions. Deviations from the colours and shapes shown in the illustrations may occur. No liability is accepted for errors and printing errors. The right to introduce modifications is reserved. Not to be reproduced, including in part, without the written approval of Audi AG.

Valid from October 2008

Printed in Germany

833/1200.39.18