



Audi

S8





Today we train our luxury limousines –
so that they continue this tradition.

History was made in October 1937. The Auto Union streamlined Model C was the first vehicle to top 400 km/h in road driving. The secret behind this exceptional performance was the special design: the streamlined car combined high-performance engine technology with a lightweight aluminium structure and an aerodynamic shape. A successful combination that Audi has adopted as a principle: performance is improved not by mere increases in

engine capacity but by the optimum co-ordination of all the car components. Audi has applied this principle of intelligent power not only to its sports cars but also to a luxury limousine. Join us on an unusual training drive in the Audi S8.



00.05.10

**To perform excellently, an athlete trains hard
and regularly: up to 7000 times a minute.**

Sprinting is followed by endurance training. Countless repetition is the key to success. Athletes are only capable of performing exceptionally well over long distances too afterwards if they work on their stamina over and over again, with absolute determination and uncompromising commitment. The Audi S8 therefore repeats the same exercises up to 7000 times a minute. At 7000 rpm, it achieves an astonishing 331 kW – extraordinary figures for luxury limousines.

It develops such impressive power over practically the entire speed range. The engine reaches its maximum torque of 540 Nm at 3500 rpm. 90% of this enormous power are already available at 2300 rpm. The result is tremendous acceleration that is not reined in until the controlled top speed of 250 km/h is reached. Breathtaking performance coupled at the same time with the most satisfying of luxuries: awareness of one's own superiority.

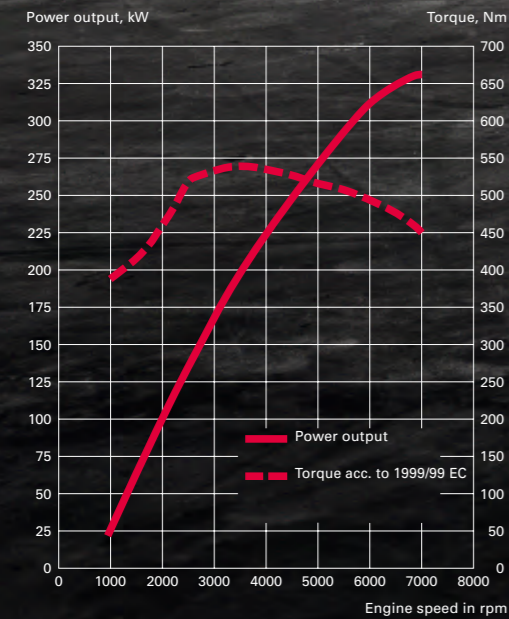

The heart of a competitive sportsman beats in the Audi S8: the first 10-cylinder engine with direct petrol injection. Its throaty sound reveals before it has even started what power is at your command. This power and dynamic performance are allied in absolute harmony with the maximum of comfort that can be expected in a luxury limousine. The 5.2-litre engine and the 10 cylinders with four valves each guarantee an extremely smooth ride. The compact design and

lightweight structure of the aluminium-alloy engine save weight and – in combination with the FSI® technology used in motorsport – fuel as well. The highly efficient FSI® injection process was taken over from the legendary Audi R8, which crossed the finishing line first for the fifth time in six years in the 2005 Le Mans 24 Hours race.



The right attitude to the race is a question of training.

A superior performance is a question of genes.



It is obvious at first glance that the Audi S8 is an outstanding performer. An athletic appearance is only part of it; the aerodynamic design, which it owes to hard training in the ultramodern Audi wind tunnel centre, is even more impressive. Because appearance was never an end in itself when the Audi S8 was being developed: its driving performance benefits from every single detail of the car's design. The wide air inlets next to the fog lights supply the V10 FSI® engine with additional air for cooling purposes. The spoiler integrated in the boot lid improves roadholding. And the eye-catching 20-inch cast aluminium wheels with S styling help the engine's power to be applied to the road.

Design elements that boost performance – and make a big impression at the same time: the pairs of oval tailpipes, the bright LED tail lights and the front fog lamps with aluminium-finish surrounds set distinctive accents. And the high shoulders, the striking singleframe and the roof line reminiscent of a coupé give the S8 a self-confident, superior look with not a touch of arrogance.

**There are ups and downs on the way to the top.
Good to be prepared for them.**

Versatility is what distinguishes a true athlete. He does not reveal any weaknesses but demonstrates many different strengths. And he responds to any challenge appropriately and confidently – where the Audi S8 is concerned, this means with a particularly sporty or leisurely answer, depending on the situation. The Audi adaptive air suspension – sport with its specific S set-up is what gives the car this confidence. The sporty running gear and the new steering set-up communicate direct contact with the road surface to you. The innovative, firm air suspension set-up permits agile, dynamic driving – without any need for you to sacrifice comfort. While you are moving, the adaptive air

suspension – sport analyses the current driving situation constantly and adapts the suspension to the specific circumstances. You decide the level of sporty or leisurely driving yourself by choosing the suspension mode: the more leisurely comfort mode or the particularly sporty dynamic mode. The automatic level regulation facility makes sure at the same time that the body is always the same distance away from the road – no matter how the car is loaded. The level is lowered automatically at higher speeds. The result: more stability while driving and lower fuel consumption thanks to less air resistance.





**A good athlete needs two things:
absolute fitness and the right technique.**



moment and subsequently accelerating powerfully out of it again. This is how the Audi S8 saves the seconds that may prove to be crucial at the finishing line. What it needs to do this is a brake system that stops

To finish in the lead, you need to be able to vary your pace during the race. Applied to road training, this means: driving at high speed for as long as possible on the straights, then braking hard into the corner at exactly the right

its awe-inspiring 331 kW at precisely the right time: the 18-inch high-performance brake system which guarantees excellent deceleration even when put to a gruelling test. The Audi ceramic brake is available as an optional extra on the Audi S8. It performs convincingly at high temperatures and under demanding braking conditions too by providing outstanding deceleration. The brake system saves weight as well, which helps to make the car even more dynamic to drive. The brake discs are produced from carbon fibre-reinforced ceramic material and make a strong visual impression too thanks to the surface that is typical of ceramic brakes, the perforated brake discs, the anthracite-coloured calliper brakes and the "Audi ceramic" logo on the front calliper brakes.

A wide-angle, front-facing view of the Audi S8 interior. The steering wheel is leather-wrapped with the Audi logo and 'S8' branding. The instrument cluster features analog gauges with red needles and a central digital display showing temperature and speed. The center console has a large infotainment screen displaying radio stations. The gear shifter is leather-wrapped with a silver knob. The interior is finished with light-colored leather and dark carbon fiber accents.

**Success depends on more than just power
and speed: inner strength.**

Superiority and exclusivity cannot be created by training; they are innate characteristics. In the Audi S8, high-quality materials and painstaking craftsmanship make it immediately obvious that you are sitting in a sports car – and in a luxury limousine at the same time. The high, leather-trimmed centre console, the attractive carbon and brushed aluminium strips and the instruments with their coloured background and white hands emphasise both the luxurious and sporty sides of the Audi S8. An impression that you can feel too. When you hold the multifunctional sports leather-covered steering wheel with three-spoke styling, for example. The seams in a contrasting colour are both elegant and sporty. The switching rockers have an aluminium look. The gear lever knob is made of leather and also has an aluminium

look. Further aluminium trim can be found on the door pockets and on the steering wheel. The sports seats in bicolour Valcona leather with colour-contrasting seams (single-colour seats are available if desired) provide optimum lateral support in dynamic driving and maximum comfort on long journeys. The centre console and door armrests are covered in fine Nappa leather with decorative seams. The impressive range of equipment in the S8 includes, for example, an optional Bose Surround Sound system, a CD changer and a navigation system. And the optional Bang & Olufsen Advanced Sound System with a total of 14 high-end loudspeakers and an output of more than 1,000 watts guarantees optimum sound quality.



Switching rockers with an aluminium look



Bang & Olufsen Advanced Sound System (optional)



Door entry strip with the S8 logo



MMI® and comfort key with engine start button

Inlays

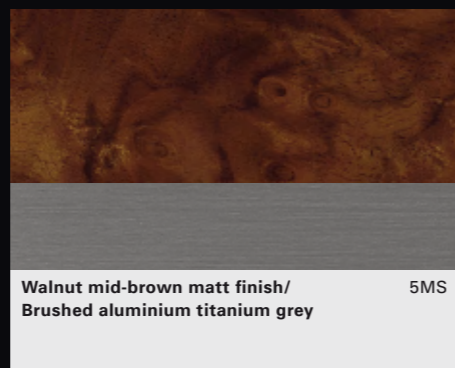
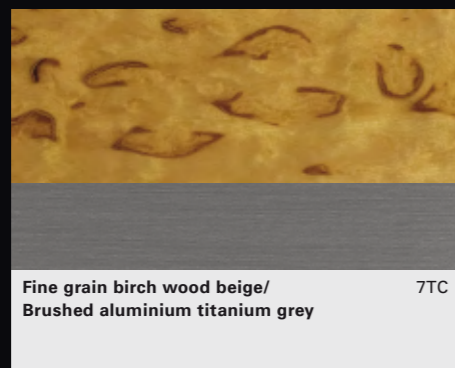
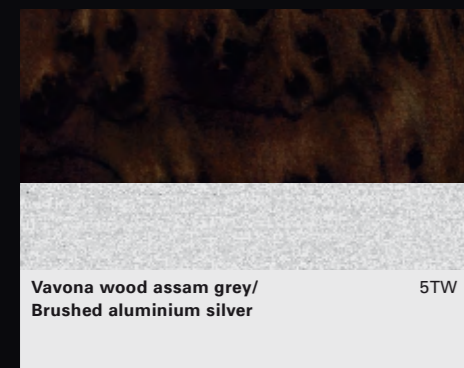
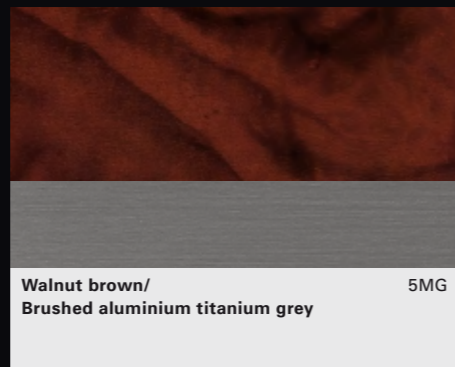
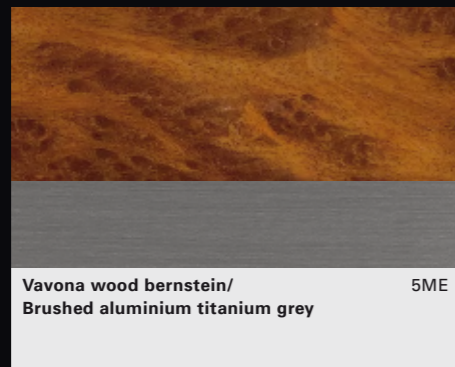
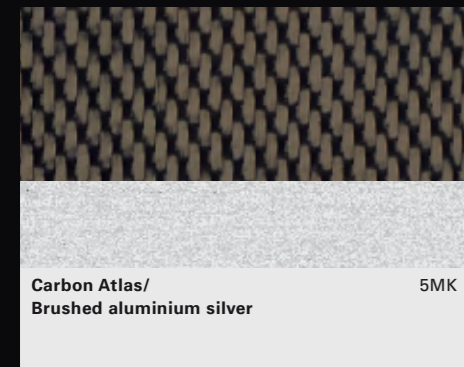

Wheels/tyres

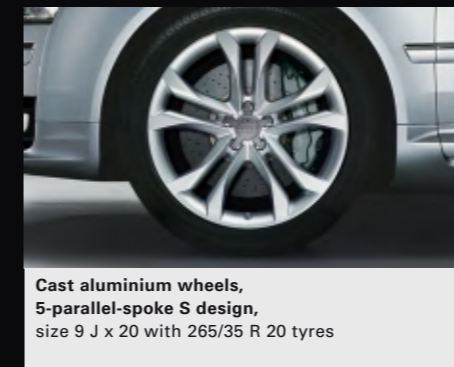

Note:

¹ Includes space-saving spare wheel.

Equipment

Paints

Metallic/pearl effect paints
Audi exclusive individual paints, individual choice of colour. From quattro GmbH

Exterior equipment

Roof systems, closing systems, glazing, further exterior equipment

Roof systems
Glass tilt/slide sunroof with tinted single-glazed safety glass and infinitely adjustable sun shield; electrically extending wind deflector (speed-dependent), automatic pre-selection for desired sunroof position; convenience closing from outside via the central locking system and the remote control
Solar tilt/slide sunroof , a continuous air flow reduces the interior temperature of the parked car; operated like the glass tilt/sliding sunroof (but has no infinitely adjustable sun shield)
Closing systems
Anti-theft alarm system , monitors the doors, bonnet and tailgate and the interior; includes electronic immobiliser, ultrasonic interior monitoring (can be deactivated) and back-up horn independent of the vehicle electrical system; incorporated into engine control unit; automatically activated by the vehicle key
Anti-theft alarm system with tow-away protection , same functionality as anti-theft alarm system; includes tow-away protection via angle of inclination sensor (can be deactivated)
Pre-installation fitting for vehicle tracking system , interface for connecting a vehicle tracking system that quickly and reliably locates the vehicle in the event of it being stolen
Garage door opener (HomeLink) , programmable radio-operated remote control, operating buttons incorporated in the front roof module; can be used to open garage doors and exterior gates; allows control of security and lighting systems (for more information on all compatible manual transmitters, please contact your Audi partner)
Tailgate, electrically opening and closing ; opened via button on vehicle key, button in the driver's door trim or soft touch button in the tailgate handle recess, closed via button on inside of tailgate
Comfort key , access and drive-away authorisation system: the key only needs to be carried with you, the engine is switched on and off via the start/stop button on the centre console, the vehicle is locked from outside via buttons on all door handles
Engine start button , in the centre console
one-touch memory , Audi personalisation system; identification field incorporated into the start button, identifies the driver by his fingerprint and retrieves his personal settings, stored in the MMI, for the deluxe automatic air-conditioner, seat, steering column and radio
Power-assisted tailgate closing , automatically pulls a tailgate that is not completely engaged into the lock
Power-assisted closing for the doors , automatically pulls doors that are not completely engaged into the lock
Door handles with aluminium finish trim

Glazing
Double glazing , two panes joined together by a plastic film; improves exterior noise insulation and increases theft protection
Insulating glass , two panes joined together by a plastic film; improves exterior noise insulation and increases theft protection; with additional reflective coating to reduce interior heat build-up
Insulating glass with windscreen heater , full-surface heating of the windscreen without distracting heating wires, automatic control of the heating via the deluxe automatic air conditioner; makes rapid defrosting easier and ensures that the windscreen stays mist-free
Privacy glass , dark-tinted rear window, rear door windows and rear side windows
Sunblinds , protect the rear passengers from direct sunlight
electrically operated for the rear windscreen
electrically operated for the rear windscreen and manually operated for the rear side windows
electrically operated for the rear windscreen and the rear side windows; electrically operated also via roof module in rear
Further exterior equipment
Trailer towing hitch , removable and lockable, the 13-pin socket can be swivelled out of sight behind the bumper skirt; when removed, the towing device can be stored in the spare wheel well
Exhaust tailpipes , dual-branch twin tailpipes, oval-shaped, chrome look
Rear spoiler , body-coloured, incorporated into body
Radiator grille , in Platinum Grey, with twin aluminium look vertical struts
S8 logo , in radiator grille, on the tailgate, on the door sill strips, on the front brake callipers, on the leather sports steering wheel and in the rev counter
V10 logo , on the front wing
Bumpers , body-coloured, S styling front and rear

Wheels/tyres

Cast aluminium wheels, 5-parallel-spoke S design , size 9J x 20 with 265/35 R 20 tyres
Audi exclusive forged aluminium wheels, 9-spoke design, polished, two-tone , size 9 J x 20 with 275/35 R 20 tyres, (including space-saving spare wheel). From quattro GmbH
Audi exclusive forged aluminium wheels, 9-spoke design, high-gloss polished-finish, single colour , size 9 J x 20 with 275/35 R 20 tyres (including space-saving spare wheel). From quattro GmbH
Audi exclusive forged aluminium wheels, 7-double-spoke design, polished, two-tone , size 9 J x 20 with 275/35 R 20 tyres, (including space-saving spare wheel). From quattro GmbH

Audi exclusive forged aluminium wheels, 7-double-spoke design, high-gloss polished-finish, single colour , size 9 J x 20 with 275/35 R 20 tyres (including space-saving spare wheel). From quattro GmbH
Winter wheels, 5-parallel-spoke S design, size 9 J x 20 with 265/35 R 20 tyres , permissible top speed 240 km/h; cannot be fitted with snow chains
Winter wheels, 16-spoke design, size 8 J x 19 with 235/45 R 19 tyres , permissible top speed 210 km/h; can be fitted with snow chains
Wheel bolts with anti-theft locks , can only be loosened using adapter provided
Tyre pressure monitoring system , during a journey monitors the set tyre pressures, including on spare wheel; also works with factory-fitted winter wheels; air pressures and wheel temperatures can be displayed in the MMI system
Tyre repair kit , with 12V compressor and tyre sealant
Spare wheel , space-saving (no-cost option)

Lights and mirrors

Lights, mirrors
Lights
adaptive light with LED daytime running lights , consisting of turning light and dynamic cornering light, including Xenon plus; the turning light automatically switches on when the indicators have been engaged for a while and illuminates the new driving direction; the dynamic cornering light identifies the course of the road from the movement of the steering wheel and dynamically illuminates bends by means of swivel headlights; additional 5 LEDs in each inner headlight tube for daylight running light or position light function
Interior and exterior lighting package , interior: LED technology for door pockets, footwells and inside door handles, door trims indirectly illuminated, reading lights integrated into the rear roof module; various lighting profiles can be configured via the MMI; exterior: courtesy lighting below the exterior mirrors and LED door handle lighting to make getting in and out of the vehicle much easier in the dark; automatically activated when unlocking and opening the doors; includes active door reflectors
Front fog lights , incorporated into the front apron, rectangular with chrome trim
Headlight cleaning system , uses water and high pressure – for excellent illumination and improved visibility
Xenon plus , headlights with gas discharge technology for dipped and main beam, includes headlight cleaning system and dynamic headlight range control; for intensive illumination of the road, both close-up and in the distance, in a colour resembling daylight
Mirrors
Exterior mirrors with aluminium look , automatically dimming and electrically folding on both sides, aspherical, with memory function and integral LED indicator
Interior mirror , automatically dimming, a photocell detects if headlights of vehicle behind are too bright and automatically dims the mirror

Seats

Seats, seating comfort, seat covers/leather packages
Seats
Sports seats with memory function , pronounced side bolsters and comfort head restraints for the front seats; electrical adjustment of fore/aft position, seat height, seat and backrest angle, upper backrest, thigh support, lumbar support, head restraint and belt height and steering wheel; memory function for driver and front-passenger seats; steering wheel, left and right exterior mirrors, front head restraints and belt height. (Can only be ordered with Valcona leather, Natural leather or Alcantara/Leather)
Comfort seats with memory function , with softer upholstery and front comfort head restraints; electric adjustment and memory function same as sports seats with memory function
Individual rear seats , electrically adjustable, including automatic exit assistance, selectable via MMI. (Only in conjunction with comfort seats)
Seating comfort
Fore/aft position of front-passenger seat electrically adjustable from the rear , allows additional legroom for the rear passenger behind the front passenger seat
Comfort head restraints in the rear , flexible side bolsters ensure good lateral support and more comfort; the side bolsters are manually adjustable individually
Comfort centre armrest at front , split for driver and front passenger, with fold-open storage compartments, adjustable angle
Lumbar support for driver and front-passenger seats, with electric horizontal and vertical adjustment
Lumbar support for the outer rear seats, with electric horizontal and vertical adjustment
Massage function for driver and front passenger seats, also for the outer rear seats if required; massages and relaxes the back muscles by moving the electric lumbar support. (Can only be ordered in conjunction with comfort seats and seat air conditioning)
Centre armrest at front for the driver and front passenger , one-piece folding design
Rest cushions , single or pair, in leather, for attaching to the rear head restraints; coordinated with the selected interior colour
Audi exclusive rest cushions , in leather or Alcantara. From quattro GmbH
Seat heating for driver and front-passenger seats and for the outer rear seats, heats the seat cushions, seat bolsters and backrests and is individually adjustable in 6 stages for each seat
Seat air conditioning at front , includes seat heating; ventilation of the seat centre panel of the two front seats for a pleasant seating climate, even when the outside temperature is high. (Can only be ordered in conjunction with comfort seats, perforated Valcona leather or Natural leather and massage function)
Seat air conditioning at front and rear , includes seat heating, ventilation of the seat centre panel of the two front seats and outer rear seats. (Can only be ordered in conjunction with comfort seats, perforated Valcona leather or Natural leather, massage function, individual seats in the rear and four-zone deluxe automatic air conditioner)

Model S8 5.2 FSI quattro

Engine type	V10 petrol engine with direct fuel injection
Displacement in cc (valves per cylinder)	5204 (4)
Max. output¹ in kW at rpm	331/7000
Max. torque in Nm at rpm	540/3500

Power transmission/wheels

Type of drive	quattro® permanent all-wheel drive
Transmission	6-speed tiptronic
Wheels	Cast aluminium wheels, 9 J x 20
Tyres	265/35 R 20

Weights/capacities

Unladen weight² in kg	1940
Gross vehicle weight in kg	2540
Roof load/trailer nose weight in kg	100/95
Trailer load limit³ in kg	unbraked 750
	12% gradient 2300
	8% gradient 2300
Fuel tank capacity, approx. in l	90

Performance/consumption⁴

Top speed⁵ in km/h	250
Acceleration 0–100 km/h in s	5.1
Fuel grade	SuperPlus unleaded 98 RON ⁶
Fuel consumption⁷ in l/100 km	urban 19.5
	extra-urban 9.5
	combined 13.2
CO₂ emissions⁷ in g/km	urban 464
	extra-urban 226
	combined 314
Emissions standard	EU4

Notes

- ¹ The figure given was calculated using the specified measuring procedure (current applicable version of Directive 80/1269/EEC).
- ² Weight of car, unladen, without driver (calculated in accordance with the current applicable version of Directive 92/21/EEC). Optional equipment may increase the car's unladen weight and its drag coefficient, whereupon the possible payload limit and top speed will be reduced accordingly.
- ³ The engine's power output always goes down with increasing altitude. At 1,000 m above sea level, and for every additional 1,000 m, deduct 10% from the weight of the outfit (trailer load limit + gross weight of the towing vehicle).
- ⁴ A vehicle's fuel consumption and CO₂ emissions do not just depend on how efficiently the vehicle uses fuel, but are also influenced by driving behaviour and other non-technical factors. CO₂ is the greenhouse gas primarily responsible for global warming
- ⁵ Regulated.
- ⁶ We recommend using SuperPlus unleaded (98 RON). If this is not available use super unleaded (95 RON); power output will be slightly reduced.
- ⁷ The figures given were calculated using the specified measuring procedure (current applicable version of Directive 80/1268/EEC). The figures do not refer to one individual vehicle and do not form part of an offer, but rather should be used purely for purposes of comparison between the different vehicle models.

Important note

Inspections are due as shown by the service display.

Audi S8

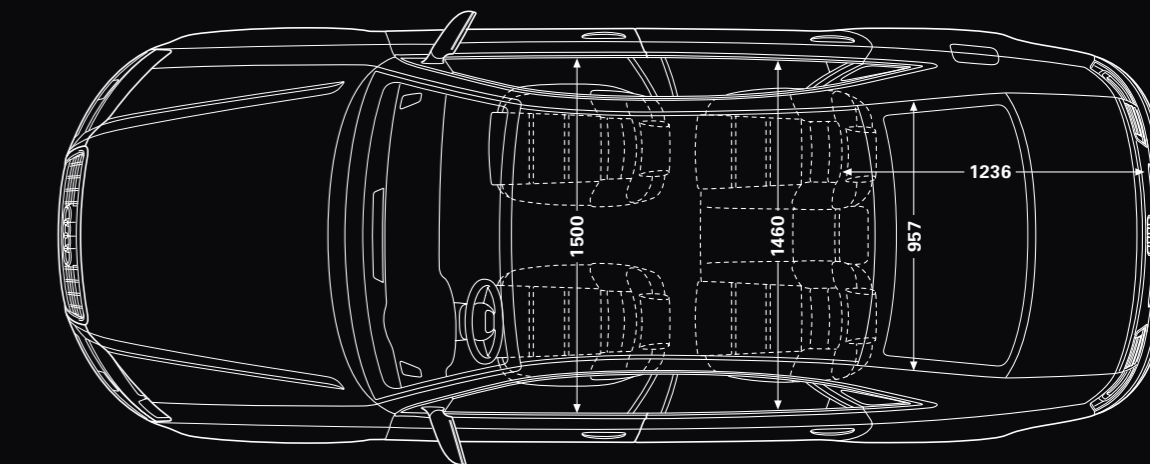
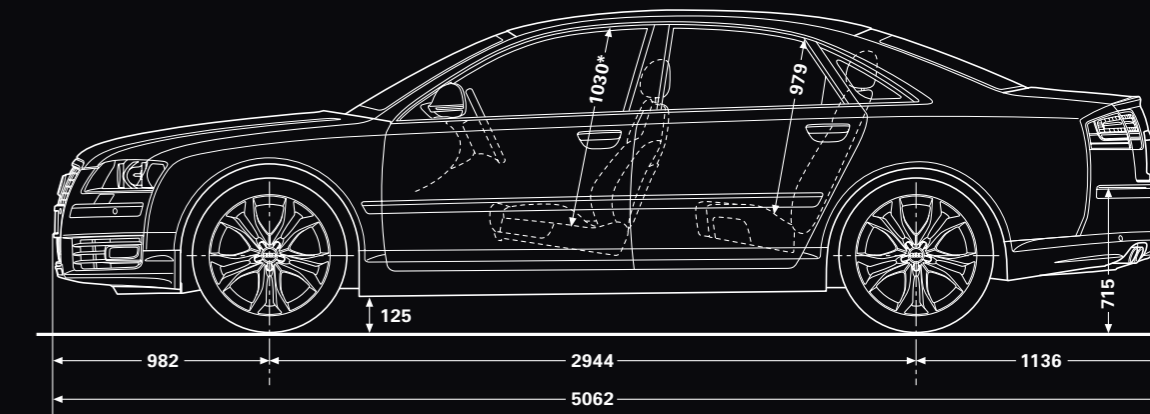
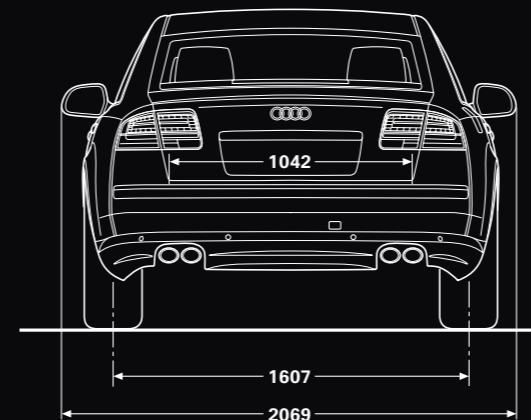
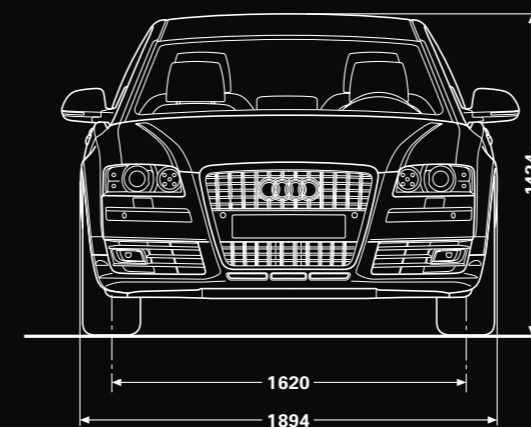

Dimensions in millimetres.

Dimensions were measured with vehicle at unladen weight, ground clearance measured with vehicle carrying its maximum load. Luggage compartment volume in l: 500 (measured by the VDA test method using 200 x 100 x 50 mm blocks). Turning circle approx. 12.1 m

*Maximum headroom.

The models and equipment versions illustrated and described in this brochure and some services listed are not available in all countries. Some of the cars illustrated are equipped with optional equipment for which an extra charge is made. Details concerning the delivery specifications, appearance, performance, dimensions and weights, fuel consumption and running costs of the vehicle were correct to the best of our knowledge at the time of going to press. There may be some variations between the Australian vehicle specifications and those manufactured for other markets. Please speak to your Audi Dealer should you have any questions. Deviations from the colours and shapes shown in the illustrations may occur. No liability is accepted for errors and printing errors. The right to introduce modifications is reserved. Not to be reproduced, including in part, without the written approval of Audi AG.

Valid from August 2008

Printed in Germany

833/1100.82.18