



Audi

Audi A3 Cabriolet



Shaped by a century of success: in every one of our vehicles you can feel the beating heart of Audi. Convince yourself of our passion for technology, design and efficiency. And enjoy your own Vorsprung durch Technik in your new Audi A3 Cabriolet.

Must-have.

The Audi A3 Cabriolet.



10 // 13
HOOD

All good things come in threes. And at minus three too.

Real cabriolet enthusiasts drive with the top down. All the time. But to see why the hood of the A3 Cabriolet is still worth a look, turn to page 10.



18 // 23
INTERIOR

Plenty for four.

Space to enjoy, space for storage, space for four people and the best journey ever. To see the inner qualities of the A3 Cabriolet, turn to page 18.

30 // 31
DRIVING PLEASURE

Good entertainment.

The Audi A3 Cabriolet has practically everything. Except boredom. To find out why a journey in the A3 Cabriolet is so much fun, turn to page 30.

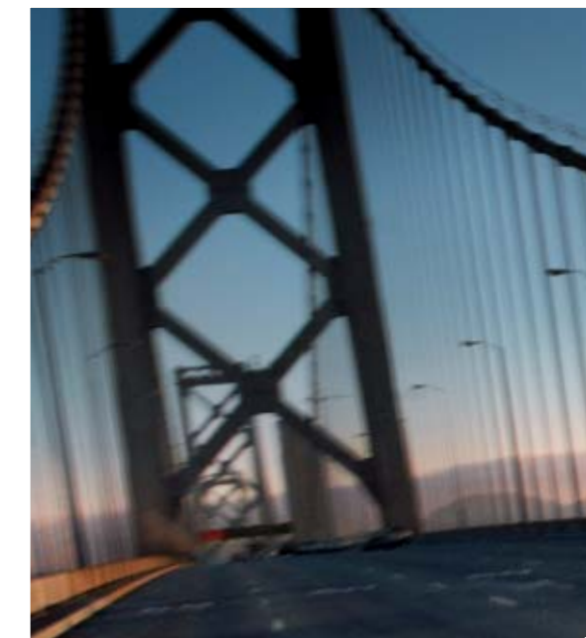

04 // 09
DESIGN

Dazzling.

The A3 Cabriolet makes a sunset into a feast for the eyes. Because you pay more attention to the car than you do to the sun. To take a look, turn to page 4.



14 // 17
ENGINE

Ready, steady, go!

The hood can be opened in no time at all to listen to the wind. But what's even better to listen to is the sound of a pure-bred engine. And the joyful laughter of your passenger when you accelerate. To read all about what it feels like, turn to page 14.



24 // 29
SAFETY

Awesome strength.

The high-strength passenger cell makes your journey a really safe one. And the roll-over bars set a visually powerful accent. To see what other features the A3 Cabriolet has to keep you safe, turn to page 24.



38 // 55
EQUIPMENT

44 // 47
STYLE GUIDES

56 // 58
TECHNICAL DATA, DIMENSIONS

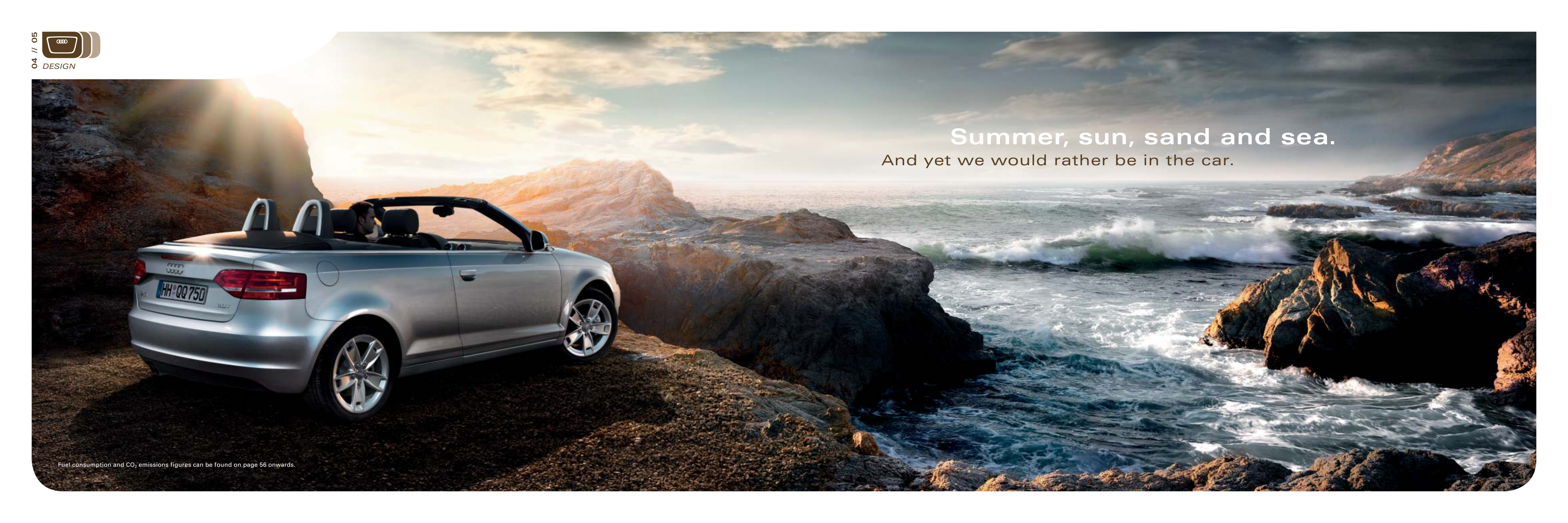

Summer, sun, sand and sea.
And yet we would rather be in the car.



An integral whole. When closed, the classic fabric hood reinforces the A3 Cabriolet's* coupé-like persona. It blends fully into the vehicle's lines and provides excellent noise and heat insulation.

Smart apparel. Thanks to the intelligent concertina folding action, no tonneau cover is required.

Only the sky is the limit. The fully-automatic acoustic hood can be opened in nine seconds and closed in eleven – even during the journey. And all very conveniently at the press of a button. The fully-automatic acoustic hood ensures your journey in the passenger compartment is always a quiet one and also provides excellent heat insulation.

*Fuel consumption and CO₂ emissions figures can be found on page 56 onwards.

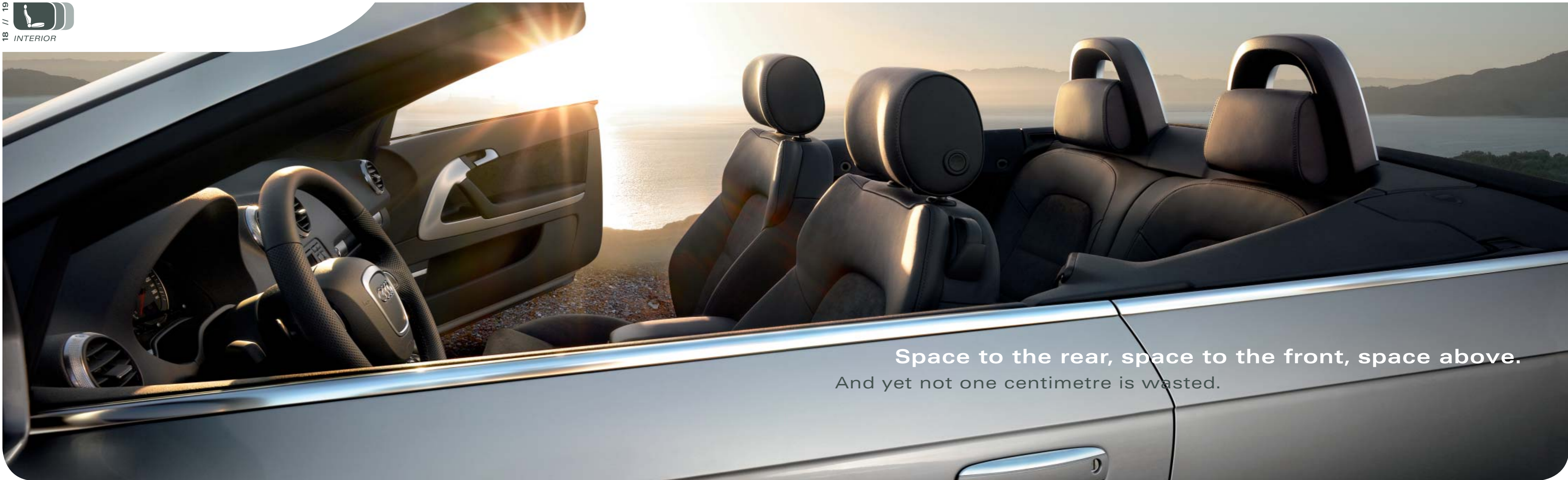

Space to the rear, space to the front, space above.
And yet not one centimetre is wasted.



01 There in black-and-white. The instrument cluster with driver information system¹ features brilliant white displays on black dials.

02 Freedom for free time. The A3 Cabriolet² offers more space than you may think. The rear bench seat can be folded 50:50 or completely. Another practical touch is the front passenger seat whose backrest can be folded back to create a virtually flat surface, thereby enabling long objects to be loaded into the car.

03 Now. And hurry. The optional navigation system plus fits harmoniously into the centre console switch panel. Its high-resolution colour display will conveniently show you the shortest way home. Although you would probably love to take a detour.

We have thought of everything.

The design in detail.



04 Resolution: do more sport! The multifunction leather sports steering wheel in 3-spoke design³ is flattened at the bottom and comes with gearshift paddle switches if required. And with its aluminium trim inserts, it cuts a very athletic figure.

05 Sun at the press of a button. Anyone opting for the acoustic hood can open it fully automatically in nine seconds – with just one press of the hood-opener button in the interior. The hood can be activated up to a vehicle speed of 30 km/h.

06 Quick change. With S tronic⁴, gearshifting is done in fractions of a second and is barely perceptible. Not only does S tronic ensure you make swift progress, it also adds a dynamic accent to the interior.

07 Fantastic atmosphere. One press of the button and the summer heat melts away. The air conditioning system is operated intuitively enabling straightforward adjustment to your desired temperature.

08 Take your seats! Four full-size seats invite you for a drive. The seats are covered in high-quality fabrics or, if desired, with elegant leather or a

combination of Alcantara and leather. If you wish, you can take your seat at the front in specially-designed sports seats.

09 Everything to hand. The 3-spoke sports leather steering wheel, standard on the Ambition trim line, features elegant aluminium-look trim inserts.

10 A symphony for the road. The BOSE Sound System gives you a very special sound experience. If you wish, you can listen to your favourite music from eight loudspeakers producing a total output of 222 watts. One subwoofer, two tweeters, one centre speaker and one 74 watt external DSP amplifier complete the rich sound experience – turning every journey into a concert performance.

11 Rounding things off nicely. The stylish air vents bring to mind a sports car.

12 Trio in harmony. The door opener, door handle and armrest form one visual unit and blend in perfectly with the high-quality sporty interior design.

¹ Standard on the Ambition trim line, otherwise optional.

² Fuel consumption and CO₂ emissions figures can be found on page 56 onwards.

³ Optional for Ambition.

⁴ Hill-start assist is standard with S tronic.



01 Drive how you want to. A standard feature of the Audi A3 Cabriolet¹ is the dynamic suspension. The independent wheel suspension enables longitudinal and lateral forces to be absorbed separately. The result is greater directional stability and increased lateral rigidity. The sports suspension is standard on the Ambition² trim line. It lowers the ride height by 15 mm and provides a sporty ride combined with a high level of comfort.

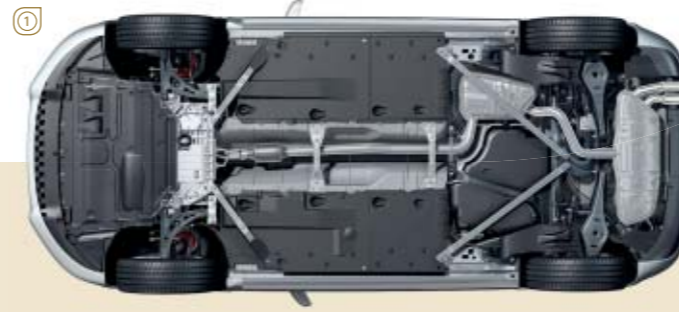

02 We take safety very seriously. That is why special reinforcements have been added to the A3 Cabriolet¹ to produce a very sturdy body. A high proportion of high-strength and super high-strength steels makes the vehicle compact, without compromising on driving pleasure. And not only do the roll-over bars look good, they offer even better protection.

03 Good humoured and well protected. The A3 Cabriolet¹ is equipped with full-size airbags³ for driver and front passenger. The side impact protection consists of super-high strength door impact bars, head/thorax side airbags³ and protective side padding. The integral head restraint system restrains the upper body, thanks to the specially-shaped seat, and provides additional support for the head. Three-point seatbelts, complete with belt tensioners and belt force limiters in the front, round off the safety features in the A3 Cabriolet¹.

¹ Fuel consumption and CO₂ emissions figures can be found on page 56 onwards.

² The Ambition trim line is also available with the standard suspension.

³ The image is an illustration, not a real representation.





It has been a long day and a long journey.

And yet you still want more. The Audi A3 Cabriolet*.



*Fuel consumption and CO₂ emissions figures can be found on page 56 onwards.

Wheels/tyres



Cast aluminium wheels, 5-arm design,
size 7.5 J x 17 with 225/45 R 17 tyres
(exclusive for Ambition)



Cast aluminium wheels, 16-spoke design,
polished, two-colour, size 7.5 J x 17 with 225/45
R 17 tyres



Audi exclusive cast aluminium wheels,
20-spoke design,
two-piece, size 7.5 J x 18 with 225/40 R 18 tyres.
From quattro GmbH



Audi exclusive cast aluminium wheels,
7-double-spoke design, titanium look,
size 7.5 J x 18 with 225/40 R 18 tyres.
From quattro GmbH



Cast aluminium wheels, 5-arm dynamic design,
dark, gloss finish, size 7.5 J x 17 with 225/45 R 17
tyres



Audi exclusive cast aluminium wheels,
5-spoke design,
size 7.5 J x 17 with 225/45 R 17 tyres.
From quattro GmbH



Audi exclusive cast aluminium wheels,
5-segment spoke design,
size 7.5 J x 18 with 225/40 R 18 tyres.
From quattro GmbH



Steel winter wheels¹,
size 6 J x 16 with 205/55 R 16 tyres,
can be fitted with snow chains



Cast aluminium wheels, 10-spoke design,
size 7.5 J x 17 with 225/45 R 17 tyres



Audi exclusive cast aluminium wheels,
10-spoke design,
size 7.5 J x 17 with 225/45 R 17 tyres.
From quattro GmbH



Audi exclusive cast aluminium wheels,
7-double-spoke design,
size 7.5 J x 18 with 225/40 R 18 tyres.
From quattro GmbH



Cast aluminium winter wheels,
7-spoke design,
size 6.5 J x 16 with 205/55 R 16 tyres

Inlays

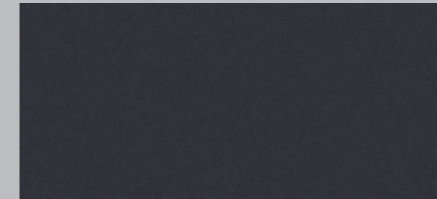

Pearlescent granite
(standard for Attraction) 5MC

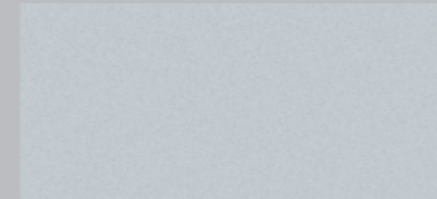

Micrometallic platinum
(standard for Ambition) 7TK



Walnut brown 5MG

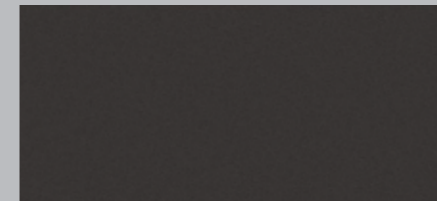

Pearlescent umbra
(standard for Attraction) 5MC



Medial Aluminium finish silver 5TD



Vavona wood bernstein 5ME

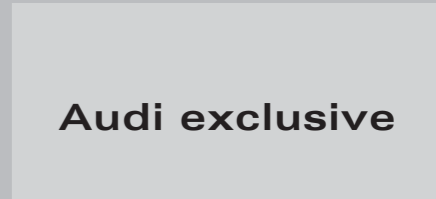

Audi exclusive inlays.
From quattro GmbH



Model	A3 Cabriolet 1.6	A3 Cabriolet 1.8 TFSI	A3 Cabriolet 2.0 TFSI	A3 Cabriolet 1.9 TDI with diesel particulate filter
Engine type	4-cylinder in-line petrol engine	4-cylinder in-line petrol engine with direct fuel injection and exhaust gas turbocharging	4-cylinder in-line petrol engine with direct fuel injection and exhaust gas turbocharging	4-cylinder in-line diesel engine with unit pump direct injection and exhaust gas turbocharging
Displacement in cc (valves per cylinder)	1595 (2)	1798 (4)	1984 (4)	1896 (2)
Max. output¹ in kW at rpm	75/5600	118/4500–6200	147/5100–6000	77/4000
Max. torque in Nm at rpm	148/3800	250/1500–4500	280/1700–5000	250/1900
Power transmission/wheels				
Type of drive	Front-wheel drive	Front-wheel drive	Front-wheel drive	Front-wheel drive
Transmission	5-speed manual transmission	6-speed manual transmission [7-speed S tronic]	6-speed manual transmission [6-speed S tronic]	5-speed manual transmission
Wheels²	Steel wheels 6.5 J x 16	Steel wheels 6.5 J x 16	Steel wheels 6.5 J x 16	Steel wheels 6.5 J x 16
Tyres²	205/55 R 16	205/55 R 16	205/55 R 16	205/55 R 16
Weights/capacities				
Unladen weight³ in kg	1330	1425 [1455]	1435 [1485]	1425
Gross vehicle weight in kg	1830	1925 [1955]	1935 [1985]	1925
Trailer nose weight in kg	75	75	75	75
Trailer load limit⁴ in kg	unbraked 700 12% gradient 1200 8% gradient 1500	750 [750] 1400 [1400] 1700 [1700]	750 [750] 1400 [1400] 1700 [1700]	750 1400 1700
Fuel tank capacity, approx. in l	55	55	55	55
Performance/consumption⁵				
Top speed in km/h	183	218 [218]	236 [236]	185
Acceleration 0–100 km/h in s	12.5	8.2 [8.0]	7.4 [7.3]	12.2
Fuel grade	Super unleaded 95 RON ⁶	Super unleaded 95 RON ⁶	Super unleaded 95 RON ⁶	Diesel in accordance with EN 590
Fuel consumption⁷ in l/100 km	urban 9.6 extra-urban 5.5 combined 7.0	9.0 [9.0] 5.6 [5.4] 6.8 [6.7]	10.0 [9.9] 5.6 [5.9] 7.2 [7.4]	6.4 4.3 5.1
CO₂ emissions⁷ in g/km	urban 228 extra-urban 131 combined 167	208 [208] 130 [126] 159 [156]	231 [229] 132 [137] 169 [171]	168 114 134
Emissions standard	EU4	EU5	EU5	EU4

[] Data for S tronic.

Model	A3 Cabriolet 2.0 TDI with diesel particulate filter
Engine type	4-cylinder in-line diesel engine with common rail injection system and exhaust gas turbocharging
Displacement in cc (valves per cylinder)	1968 (4)
Max. output¹ in kW at rpm	103/4200
Max. torque in Nm at rpm	320/1750–2500
Power transmission/wheels	
Type of drive	Front-wheel drive
Transmission	6-speed manual transmission [6-speed S tronic]
Wheels²	Steel wheels 6.5 J x 16
Tyres²	205/55 R 16
Weights/capacities	
Unladen weight³ in kg	1475 [1495]
Gross vehicle weight in kg	1975 [1995]
Trailer nose weight in kg	75
Trailer load limit⁴ in kg	unbraked 750 [750] 12% gradient 1400 [1400] 8% gradient 1700 [1700]
Fuel tank capacity, approx. in l	55
Performance/consumption⁵	
Top speed in km/h	205 [205]
Acceleration 0–100 km/h in s	9.7 [9.4]
Fuel grade	Diesel in accordance with EN 590
Fuel consumption⁷ in l/100 km	urban 6.7 [7.7] extra-urban 4.4 [4.4] combined 5.3 [5.6]
CO₂ emissions⁷ in g/km	urban 177 [203] extra-urban 117 [116] combined 139 [148]
Emissions standard	EU5

[] Data for S tronic.

Notes

- ¹ The figure stated was calculated using the specified measuring procedure (current version of Directive 80/1269/EEC).
- ² Ambition models have cast aluminium wheels, size 7.5 J x 17 with 225/45 R 17 tyres.
- ³ Weight of car, unladen, with fuel tank filled to 90% without driver (75 kg), calculated in accordance with EC Directive 92/21/EEC. Optional equipment may increase the car's unladen weight and drag coefficient, whereupon the possible payload limit and the top speed will be reduced accordingly.
- ⁴ The engine's power output always goes down with increasing altitude. At 1,000 m above sea level, and for every additional 1,000 m, deduct 10% from the weight of the outfit (trailer load limit + gross weight of towing vehicle).
- ⁵ A vehicle's fuel consumption and CO₂ emissions do not just depend on how efficiently the vehicle uses the fuel, but are also influenced by driving behaviour and other non-technical factors. CO₂ is the greenhouse gas primarily responsible for global warming.
- ⁶ We recommend using Super unleaded (95 RON). If this is not available, use regular unleaded (91 RON); power output will be slightly reduced.
- ⁷ The figures stated were calculated using the specified measuring procedures. The figures do not refer to one individual vehicle and do not form part of any offer, but rather should be used purely for purposes of comparison between the different vehicle models.

Important note

Inspections are due as shown by the service display.

The models and equipment versions illustrated and described in this brochure and some services listed are not available in all countries. Some of the cars illustrated are equipped with optional equipment for which an extra charge is made. Details concerning the delivery specifications, appearance, performance, dimensions and weights, fuel consumption and running costs of the vehicle were correct to the best of our knowledge at the time of going to press. There may be some variations between the Australian vehicle specifications and those manufactured for other markets. Please speak to your Audi Dealer should you have any questions. Deviations from the colours and shapes shown in the illustrations may occur. No liability is accepted for errors and printing errors. The right to introduce modifications is reserved. Not to be reproduced, including in part, without the written approval of Audi AG.