



mazda



MX-5



Mazda 6



Mazda 3



BT-50



Mazda 2



CX-9

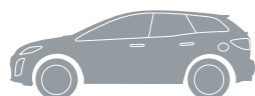

CX-7



RX-8

# Mazda BT-50



zoom-zoom



mazda

**Motion should take you wherever you want to go**

**Let you do whatever you like**

**It should let you get that bit extra done**

**Or explore that bit further**

**And never ask you to compromise**



[WATCH THE TV AD >](#)



**There's always more to experience**

**Mazda BT-50 has the strength to take it on**

**The ability to do it all**

**With luxury that makes the most of it**

**And performance that makes it great**

**It's what we call Zoom-Zoom**



## *THERE'S NO END TO WHERE IT CAN TAKE YOU*

It's been built to do everything you need. And even more than that. Mazda BT-50 gets behind you with strength and ability proven in the toughest tests Australia could throw at it.

So pack it full of tools or hook up a big load, and you know it's going to come through. In fact with towing and payload capacities among the biggest around, you'll feel like nothing can stop you.

But there's much more to BT-50 than muscle. Because while sometimes there's work to be done, there's always life to be lived. So you get athletic design instead of boxy thinking. You access the latest entertainment and technology in a cabin that's more car than truck.

And you feel like you're driving a smoothly responsive SUV, thanks to handling that echoes our sports car DNA. Add the latest in safety and driver aids, and you've got anything but the usual ute.



WATCH THE ALL NEW BT-50  
ROAD TEST VIDEO >

## ALL THE STRENGTH YOU NEED. AND THEN SOME

Taking on the big jobs or taking off for a long weekend, you shouldn't have to compromise. Good thing BT-50 is built to go one better. Its ladder frame chassis is thoroughly beefed up to be one of the most rigid of any ute. As well as giving you accurate car-like handling, it enables BT-50 to perform feats of strength others struggle to match. Like towing up to a huge 3,350kg<sup>4</sup> and making light work of payloads up to 1,508kg<sup>7</sup>.

You've also got more than most others under the bonnet. New generation turbo diesel engines use advanced common-rail direct injection to squeeze out more muscle from less fuel. Boosted by a lag-reducing

variable geometry turbocharger, the punchy 2.2 litre gives you a smooth 110kW and 375Nm of torque to work with. Go for the 3.2 litre unit's 147kW and massive 470Nm, and you'll easily overpower any challenge.

So how do you prefer to put the power down? A tough 6-speed manual puts full control in your hands, while the smart 6-speed auto will happily do all the work or let you make slick manual shifts.

With either, you can take on the rough stuff without breaking your stride. In 4x4 models, you flick between 2-High and 4-High on the move via a handy switch.

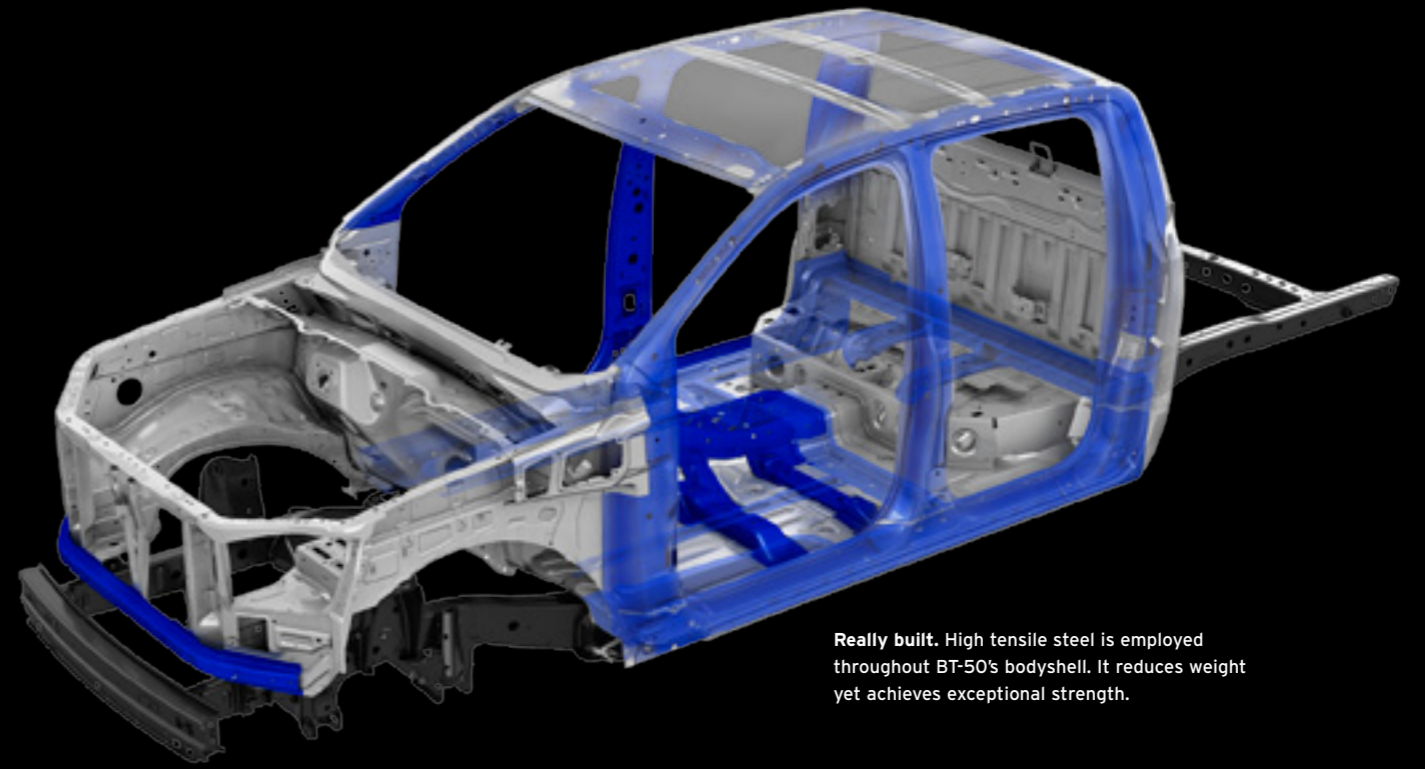

**Really built.** High tensile steel is employed throughout BT-50's bodyshell. It reduces weight yet achieves exceptional strength.

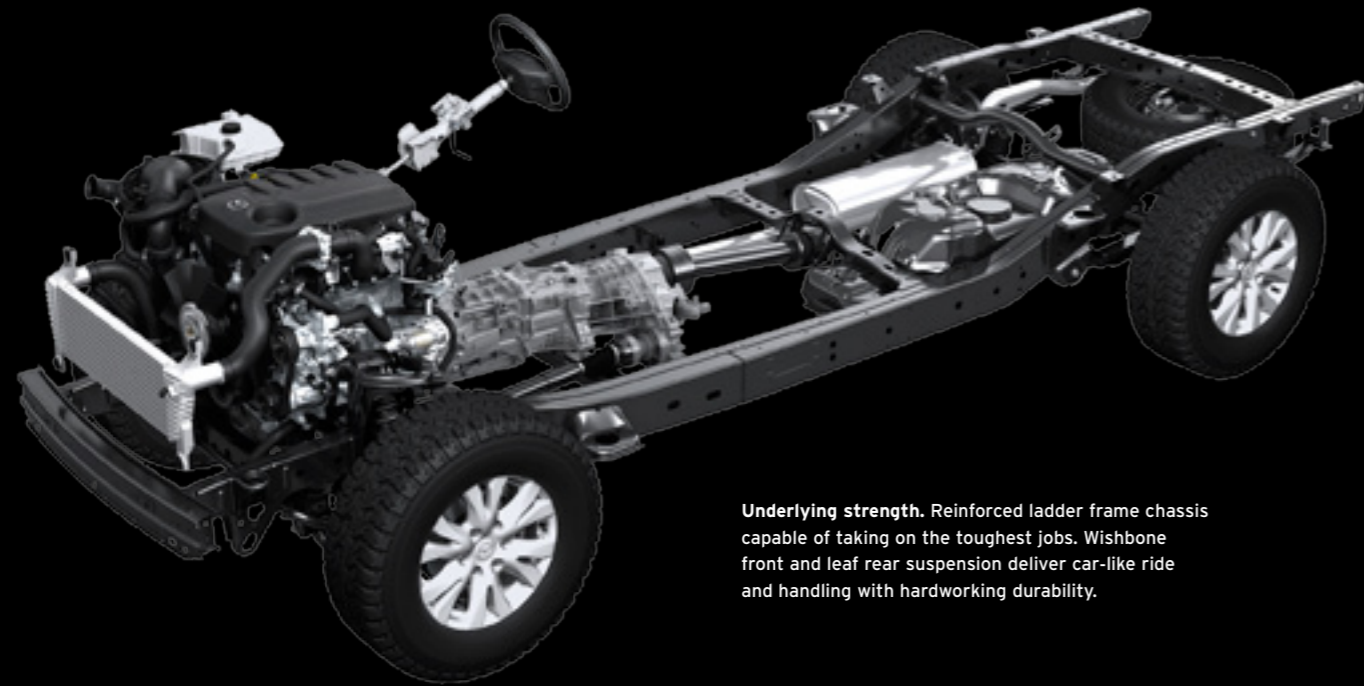

**Underlying strength.** Reinforced ladder frame chassis capable of taking on the toughest jobs. Wishbone front and leaf rear suspension deliver car-like ride and handling with hardworking durability.



**Power on.** DOHC, common-rail direct injection, turbo charging and intercooling combine to create big punch from small amounts of fuel. 3.2 litre five-cylinder engine (shown) pumps out 147kW of power and 470Nm of torque using from just 8.4 litres per 100km (combined)! 4x2 Single Cab Chassis XT's four-cylinder 2.2 litre engine gives you 110kW and 375Nm, yet uses only 7.6L/100km (combined)!

Black engine cover on XTR and GT models only.



**The right gear.** Rugged 6-speed manual's precision-shifting ratios make the most of generous power. Intelligent, seamlessly smooth 6-speed automatic lets you take manual control when the mood takes you. In auto mode Active Adaptive Shift (AAS) intuitively selects the right gear for the conditions and your driving style.



## *YOU MIGHT NOT THINK YOU'RE IN A UTE*

Wait a minute - is this really a ute? Mazda BT-50 welcomes you to the kind of comfort that's all too rare in this class. The cabin wraps around you with a sense of sophistication and the latest tech, like displays detailing everything from audio to trip computer info. Right on the steering wheel you've got switches for cruise control, audio and the standard Bluetooth® functions. Pump up the volume and the MP3/WMA compatible CD player responds powerfully through 4 speakers in Single and Freestyle Cab, 6 in Dual Cab models. USB connectivity and Bluetooth® streaming complement the performance. Need to make a few calls? Every model allows hands-free phone use. Oh, you get air con as standard too.

caters to individual comfort down to the very last degree. Your steering wheel wears luxurious leather, while satellite navigation makes taking the wheel all the more enjoyable. Nice long drive or long day at work - you'll appreciate comforting touches like chrome highlights, floor carpeting and trim that's a cut above.

Still want more? Add the extras of the GT model and you've got luxury like you've never known in a ute. Its seats are trimmed in richly inviting black leather.® Settle into them and it's effortless indulgence, as auto on/off headlamps, rain-sensing wipers and even an auto dimming rear-view mirror are included.

Of course, being a BT-50 there's more to come. Choose XTR and dual-zone climate control air-conditioning

**MP3**

**WMA**

**Bluetooth®**

## SPACE. IT'S THE ULTIMATE EXTRA

From the ground up, BT-50 has been created to be bigger, stronger, better.

You'll feel it when you tow what you thought you couldn't, or load up more than ever before. And you'll definitely feel it when you jump inside. In every direction the spacious, sporty interior has been opened up to stretch comfort way beyond what you expect.

Dual Cab models can take on five full-size adults with no fear of arguments over personal space. Single Cab models accommodate you generously too, with split bench seating that combines a driver's bucket seat with room for two others.

Maybe you need something that's somewhere in-between? The clever Freestyle Cab gives you extra interior

practicality and seating for up to four, accessed by ingenious rear doors.

Sure you can carry heaps out back in BT-50's cargo box, but you might be surprised at what there's space for inside. Look beside you, above you and even under the rear seats in Freestyle and Dual Cab, and you'll find a handy place to store drinks, sunnies, a set of tools and more.



**Really connected.** Bluetooth® enables hands-free phone use on the move and audio streaming.



**This way.** Satellite navigation features a clear 5 inch colour LCD screen in XTR and GT models.



**Comfy cuts.** Standard black cloth seat trim is comfortable and durable.



**All in.** Load areas up there with the biggest in the class mean you can take on more cargo. BT-50 can carry payloads right up to a hefty 1,508kg.



**Haul away.** Impressive strength and power makes BT-50 one of the best towers around. It can haul up to a huge 3,350kg; making light work of even the biggest loads. Optional tow bar shown above.

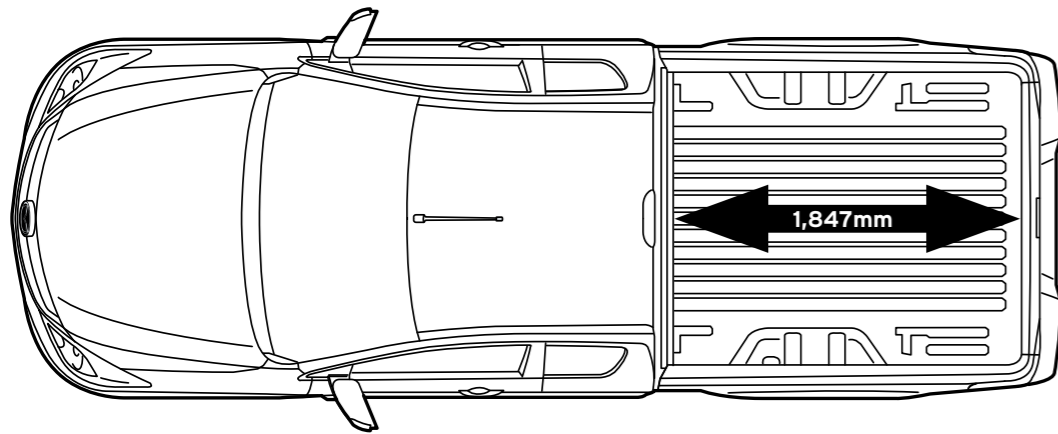

**Freestyle Cab Utility**

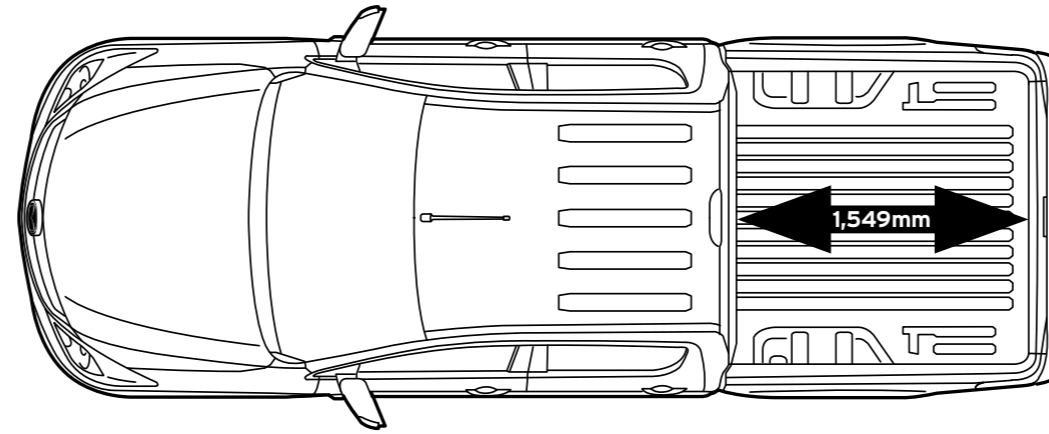

**Dual Cab Utility**



**Well placed.** Handy storage spaces are all around you, including a split-level storage box in the centre console. Glove box is big enough to take a 16 inch laptop.



**Keep control.** BT-50's superb on-road and confident off-road performance is boosted by impressive technology. In 4x4 models, Hill Descent Control (HDC) automatically applies brakes to maintain a steady, low speed down steep slopes. Control is greatly enhanced, particularly in off-road conditions.



4x4 DUAL CAB UTILITY XTR IN GUNMETAL BLUE MICA



**No stopping you.** Just flick the handy console switch and BT-50's electronically controlled transfer case lets you jump between 2-High and 4-High - without even needing to stop.



**Locked on.** On 4x4 models a Locking Rear Differential (LRD) maximises off-road grip by locking the rear wheels so both receive the same amount of torque. So even when one wheel has lost traction, the other provides drive. Can be engaged and disengaged via console switch.

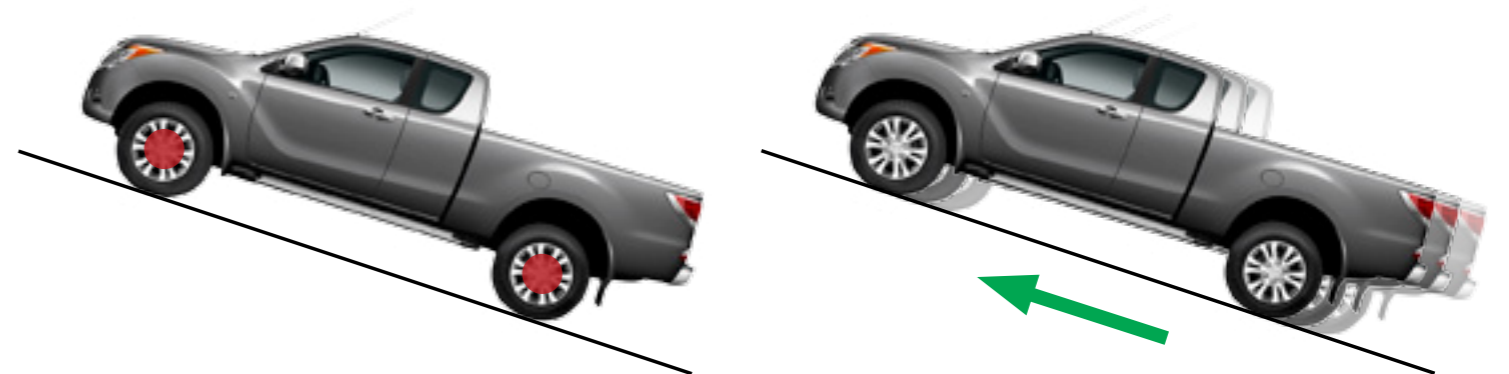

**Perfect start.** Safe, predictable starts on inclines are assured by Hill Launch Assist (HLA). It keeps the brakes applied as you remove your foot from the brake pedal to apply throttle. When there's enough torque for a smooth start, the brakes are released.

## YOU'LL FEEL MORE THAN SAFE

Mazda BT-50 lets you do more. And it will let you enjoy more confidence too.

Its responsive handling and steering mean you're well placed to avoid potential trouble - still an impressive safety arsenal is looking out for you. It begins with the superior occupant protection of a thoroughly reinforced body shell. Building your sense of safety are front airbags plus head-protecting curtain airbags in all models while Freestyle and Dual Cab models add side (front) airbags. All seats have three-position seatbelts, while front belts have pretensioners and load-limiters.

Two child restraint anchor points in the rear of Dual Cab and Freestyle Cab look after the kids. Every BT-50 has Dynamic Stability Control (DSC) incorporating Traction Control System (TCS) as standard.

What's more, the powerful brakes are backed up by ABS and Electronic Brake-force Distribution (EBD), which optimises braking force according to vehicle load. On top of that Emergency Brake Assist (EBA) monitors pedal application to recognise emergency braking, adding stopping power right when it's needed.



**Deeply reassuring.** High tensile steel and extensive reinforcing help achieve an occupant cell of exceptional strength. With up to six SRS airbags BT50 provides superior occupant safety.

**Safety at work.** Sometimes cargo can raise your vehicle's centre of gravity. Roll Stability Control (RSC) closely monitors speed, steering angle and yaw rate, and if required brakes individual wheels to help prevent a roll over. Load Adaptive Control (LAC) adjusts the ABS, DSC and Traction Control System (TCS) to optimise control in accordance with cargo weight and height.

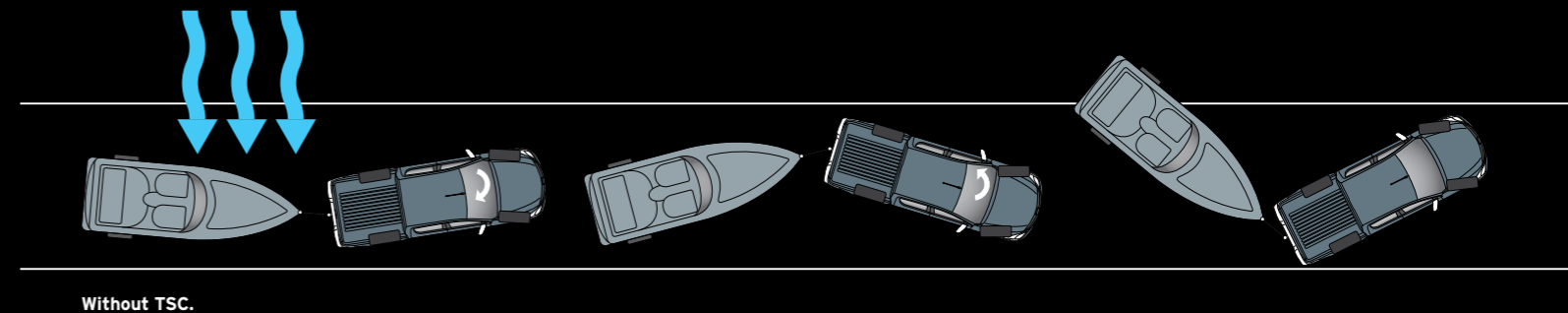
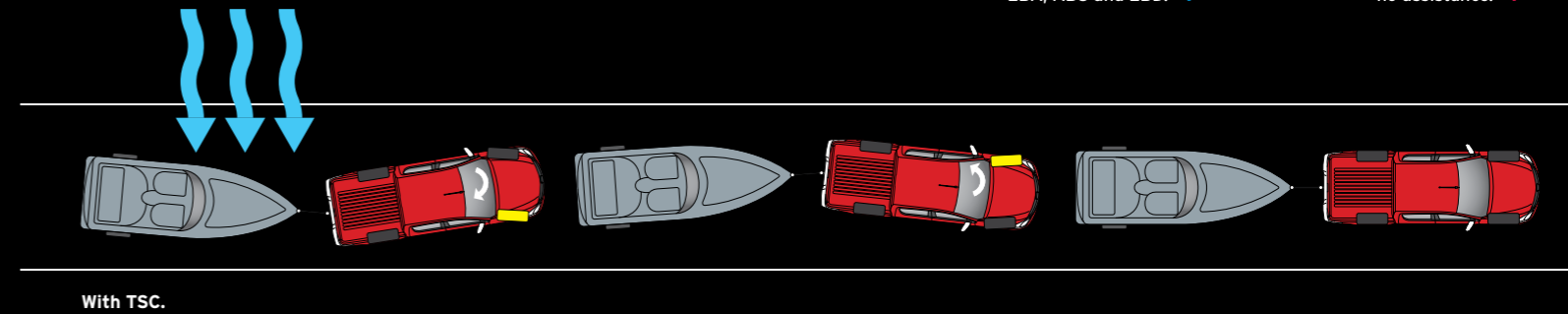
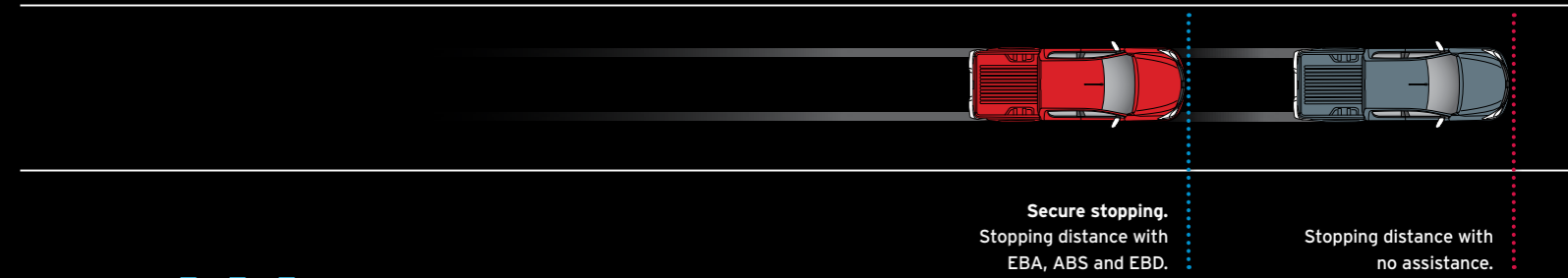

**Straight and true.** Gusts of wind or other factors can cause a trailer to start swaying. Trailer Sway Control (TSC) controls your wheels' rotation speed to reduce swaying and heighten stability.

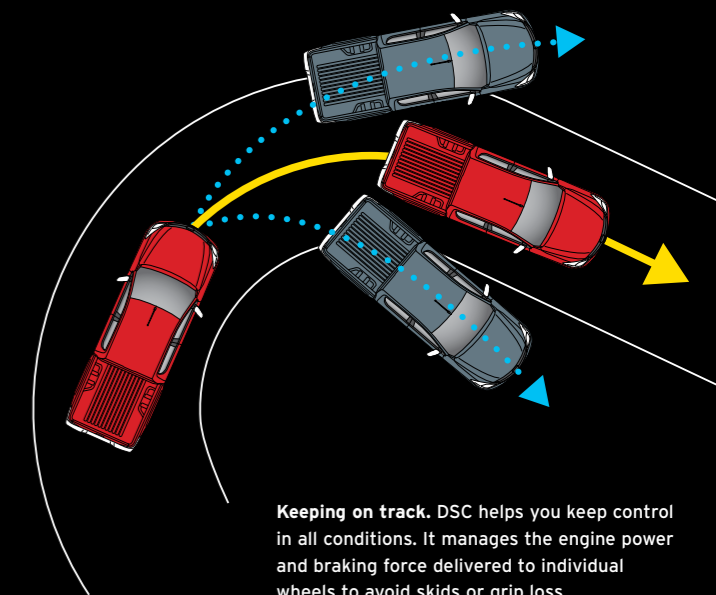

## SINGLE CAB - AVAILABLE 2012

Single Cab gives you all the comfort, technology and tough workhorse ability you'll ever need.

### XT

- 2.2 litre in-line 4 turbo diesel engine (110 kW / 375 Nm)
- 80 litre fuel tank capacity
- 6-speed manual
- 16 inch steel wheels with 215/70 tyres
- Headlamps (halogen)
- Power windows and mirrors (black)
- Air-conditioning
- Bluetooth® (hands-free compatible)<sup>5</sup>
- Cruise control
- Floor covering: vinyl
- Trip computer
- Audio system with: AM/FM tuner, single-disc CD player and 4 speakers
- Bluetooth® audio (MP3 player compatible)<sup>5</sup>
- USB input (iPod compatible)
- Airbags SRS: front (driver and passenger) and curtain (driver and passenger)
- Anti-lock Braking System (ABS)
- Dynamic Stability Control (DSC)
- Hill Launch Assist (HLA)
- Ground clearance (laden): 135 mm
- Payload: 1,306 kg
- Towing capacity (braked)<sup>4</sup>: 2,500 kg



4x2  
Cab Chassis XT



4x2  
Cab Chassis XT  
Hi-Rider



4x4  
Cab Chassis XT  
Hi-Rider

### XT Hi-Rider

- Features additional to XT:
- 3.2 litre in-line 5 intercooled turbo diesel engine (147 kW / 470 Nm)
  - 16 inch steel wheels with 255/70 tyres
  - Hill Descent Control (HDC) - 4x4 only
  - Locking Rear Differential (LRD) - 4x4 only
  - Ground clearance (laden): 200 mm
  - Payload: 1,508 kg (4x2) 1,411 kg (4x4)
  - Towing capacity (braked)<sup>4</sup>: 3,350 kg



**Very accommodating.** Single Cab's split bench seat combines driver bucket with space for two others.

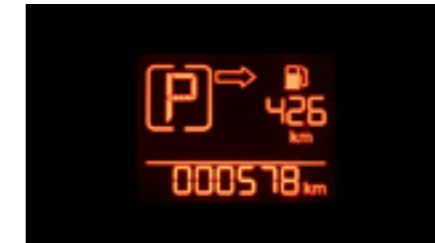

**Keep informed.** Trip computer details useful information such as fuel economy, distance to empty and more.



## FREESTYLE CAB

Want more interior room and flexibility? Easy - a clever pillarless rear door frees up extra seating and storage.

### XT

- 3.2 litre in-line 5 turbo diesel engine (147 kW / 470 Nm)
- 80 litre fuel tank capacity
- 6-speed manual
- 16 inch steel wheels with 255/70 tyres
- Headlamps (halogen)
- Power windows and mirrors (black)
- Air-conditioning
- Bluetooth® (hands-free compatible)<sup>5</sup>

- Cruise control
- Floor covering: vinyl
- Trip computer
- Audio system with: AM/FM tuner, single-disc CD player and 6 speakers
- Bluetooth® audio (MP3 player compatible)<sup>5</sup>
- USB input (iPod compatible)
- Airbags SRS: front (driver and passenger), side (front) and curtain (front and rear)

- Anti-lock Braking System (ABS)
- Child restraint anchor points (2)
- Dynamic Stability Control (DSC)
- Hill Descent Control (HDC) - 4x4 only
- Hill Launch Assist (HLA)
- Locking Rear Differential (LRD) - 4x4 only
- Ground clearance (laden): 200 mm
- Payload: 1,430 kg (4x2) 1,343 kg (4x4)
- Towing capacity (braked)<sup>4</sup>: 3,350 kg

### XTR

Features additional to the XT:

- 17 inch alloy wheels with 265/65 tyres
- Door handles (chrome)
- Fog-lamps (front)
- Power mirrors (chrome)
- Rear step bumper (chrome)
- Side steps (aluminium finish)
- Air-conditioning (dual-zone climate control)
- Ambient temperature gauge

- Floor covering: carpet
- Leather wrapped: gear shift knob and steering wheel
- Satellite navigation
- High mount stop lamp
- Ground clearance (laden): 205 mm
- Payload: 1,163 kg



4x2  
Cab Chassis XT



4x4  
Cab Chassis XT



4x4  
Utility XTR



**Freestyle freedom.** Freestyle Cab's clever door system opens up extra versatility.



**Just cruising.** Selecting and setting your speed is easy via wheel-mounted controls.



## DUAL CAB

Seriously heavy duty or a family day out - the more you want to do, the more Dual Cab's space and versatility have to offer.

### XT

- 3.2 litre in-line 5 turbo diesel engine (147 kW / 470 Nm)
- 80 litre fuel tank capacity
- 6-speed manual or 6-speed automatic - utilities only
- 16 inch steel wheels with 255/70 tyres
- Headlamps (halogen)
- Power windows and mirrors (black)
- Rear step bumper (black) - utilities only
- Air-conditioning
- Bluetooth® (hands-free compatible)<sup>5</sup>
- Cruise control
- Floor covering: vinyl
- Trip computer
- Audio system with: AM/FM tuner, single-disc CD player and 6 speakers
- Bluetooth® audio (MP3 player compatible)<sup>5</sup>
- USB input (iPod® compatible)
- Airbags SRS: front (driver and passenger), side (front) and curtain (front and rear)

- Anti-lock Braking System (ABS)
- Child restraint anchor points (2)
- Dynamic Stability Control (DSC)
- High mount stop lamp - utilities only
- Hill Descent Control (HDC) - 4x4 only
- Hill Launch Assist (HLA)
- Locking Rear Differential (LRD) - 4x4 only
- Ground clearance (laden): 200 mm
- Payload: from 1,139 kg (4x4 auto)
- Towing capacity (braked)<sup>4</sup>: 3,350 kg

### XTR

Features additional to the XT:

- 17 inch alloy wheels with 265/65 tyres
- Door handles (chrome)
- Fog-lamps (front)
- Power mirrors (chrome)
- Rear step bumper (chrome)
- Side steps (aluminium finish)
- Air-conditioning (dual-zone climate control)
- Ambient temperature gauge
- Floor covering: carpet
- Leather wrapped: gear shift knob and steering wheel
- Satellite navigation
- Payload: from 1,097 kg (4x4 auto)

### GT

Features additional to the XTR:

- Headlamps auto on/off function
- Rear-view mirror with auto dimming function
- Seat trim: leather<sup>6</sup>
- Wipers (front) 2-speed with rain-sensing function
- Payload: from 1,088 kg (4x4 auto)



4x2  
Utility XT



4x2  
Utility XTR



4x4  
Cab Chassis XT



4x4  
Utility XT



4x4  
Utility XTR



4x4  
Utility GT



**Feels fantastic.** Supportive sports seats trimmed in rich, luxurious leather<sup>6</sup> on GT and black cloth on XT and XTR.



**Secret spot.** Lifting the rear seat reveals useful extra storage space.



### Boss Adventure Pack (as shown)

Available on 4x4 XTR and GT models

- Steel bull bar (black) - airbag compatible
- Lightforce Genesis driving lights (2)
- 17 inch 5-spoke alloy wheels
- Tubular side steps (black) - airbag compatible
- Sports bar (black)
- Soft tonneau cover

### Boss Sports Pack

Available on 4x4 XTR and GT models

- Alloy bull bar - airbag compatible
- Lightforce Genesis driving lights (2)
- 17 inch 7-spoke alloy wheels
- Tubular side steps (stainless steel) - airbag compatible
- Alloy sports bar
- Hard tonneau cover (lockable)

# 4x2 SPECIFICATIONS

	4x2 Single Cab Chassis XT	4x2 Single Cab Chassis XT Hi-Rider	4x2 Freestyle Cab Chassis XT Hi-Rider	4x2 Dual Cab Utility XT Hi-Rider	4x2 Dual Cab Utility XTR Hi-Rider
--	---------------------------	------------------------------------	---------------------------------------	----------------------------------	-----------------------------------

## Powertrain

Engine type	2.2 litre in-line 4 cylinder 16 valve DOHC intercooled turbo diesel		3.2 litre in-line 5 cylinder 20 valve DOHC intercooled turbo diesel		
Engine capacity	2,198 cc		3,198 cc		
Bore and stroke	86.0 mm x 94.6 mm		89.0 mm x 100.7 mm		
Compression ratio	15.5 : 1		15.5 : 1		
Maximum power	110 kW @ 3,700 rpm		147 kW @ 3,000 rpm		
Maximum torque	375 Nm @ 1,500 - 2,500 rpm		470 Nm @ 1,750 - 2,500 rpm		
Throttle control	Electronic (drive-by-wire)		Electronic (drive-by-wire)		
Fuel system	Common-rail, electronic direct injection		Common-rail, electronic direct injection		
Fuel tank capacity	80 litres		80 litres		
Recommended fuel	Diesel		Diesel		
Fuel consumption <sup>1</sup>	man (combined)	7.6 litres per 100 km	8.4 litres per 100 km		8.9 litres per 100 km
	auto (combined)	-	-	-	-
Emissions standard	Euro stage IV		Euro stage IV		
Alternator	12 volts - 110 amps		12 volts - 110 amps		
Manual transmission	6-speed		6-speed		
Automatic transmission	-		-		6-speed
Gear ratio - man/auto	1st	5.441 / -	5.441 / -	5.441 / 4.171	5.441 / 4.171
	2nd	2.839 / -	2.839 / -	2.839 / 2.342	2.839 / 2.342
	3rd	1.721 / -	1.721 / -	1.721 / 1.521	1.721 / 1.521
	4th	1.223 / -	1.223 / -	1.223 / 1.143	1.223 / 1.143
	5th	1.000 / -	1.000 / -	1.000 / 0.867	1.000 / 0.867
	6th	0.794 / -	0.794 / -	0.794 / 0.691	0.794 / 0.691
	reverse	4.935 / -	4.935 / -	4.935 / 3.403	4.935 / 3.403
	final drive	3.310 / -	3.550 / -	3.550 / 3.730	3.550 / 3.730

## Chassis

Brake diameter	front	302 mm			
	rear	270 mm			
Brake type	front	Ventilated disc			
	rear	Drum			
Steering type	Rack and pinion hydraulic power assist steering				
Suspension type	front	Independent double wishbone with coil over dampers and anti-roll bar			
	rear	Rigid (live) rear axle with leaf springs			
Turning circle	kerb to kerb	11.8 m	12.4 m	12.4 m	12.4 m
Tyre size		215/70 R16C	255/70 R16	255/70 R16	255/70 R16
Tyre index		108/106S	111T	111T	112T
Wheel size		16 x 6.5 J	16 x 7.0 J	16 x 7.0 J	17 x 8.0 J
Wheel type		Steel	Steel	Steel	Alloy
Wheel size (spare)		16 x 6.5 J	16 x 7.0 J	16 x 7.0 J	17 x 7.5 J
Wheel type (spare)		Steel	Steel	Steel	Steel

## Weights and Capacities

Axle capacity	front	1,324 kg	1,480 kg	1,480 kg	1,480 kg	1,480 kg
	rear	1,752 kg	1,850 kg	1,850 kg	1,850 kg	1,850 kg
Gross Combined Mass (GCM) <sup>2</sup>	man	5,275 kg	5,950 kg	5,950 kg	5,950 kg	5,950 kg
	auto	-	-	-	5,950 kg	5,950 kg
Gross Vehicle Mass (GVM)	man	2,925 kg	3,200 kg	3,200 kg	3,200 kg	3,200 kg
	auto	-	-	-	3,200 kg	3,200 kg
Kerb weight	man	1,619 kg	1,692 kg	1,770 kg	1,944 kg	1,983 kg
	auto	-	-	-	1,964 kg	2,003 kg
Payload <sup>3</sup>	man	1,306 kg	1,508 kg	1,430 kg	1,256 kg	1,217 kg
	auto	-	-	-	1,236 kg	1,197 kg
Seating capacity		3	3	4	5	5
Tow ball download	maximum	250 kg	335 kg	335 kg	335 kg	335 kg
Towing capacity <sup>4</sup>	braked	2,500 kg	3,350 kg	3,350 kg	3,350 kg	3,350 kg
	unbraked	750 kg	750 kg	750 kg	750 kg	750 kg

	A 4x2 Single Cab Chassis XT	B 4x2 Single Cab Chassis XT Hi-Rider	C 4x2 Freestyle Cab Chassis XT Hi-Rider	D 4x2 Dual Cab Utility XT Hi-Rider	E 4x2 Dual Cab Utility XTR Hi-Rider
--	--------------------------------	---	--	---------------------------------------	--

## Dimensions

Cargo box floor height to ground	-	-	-	835 mm	841 mm
Cargo box floor length	-	-	-	1,549 mm	1,549 mm
Cargo box floor width	-	-	-	1,560 mm	1,560 mm
Cargo box height	-	-	-	513 mm	513 mm
Cargo box tailgate opening width	-	-	-	1,330 mm	1,330 mm
Cargo box top length	-	-	-	1,485 mm	1,485 mm
Cargo box top width	-	-	-	1,500 mm	1,500 mm
Cargo box width between wheel arches	-	-	-	1,139 mm	1,139 mm
Ground clearance	laden	135 mm	200 mm	200 mm	205 mm
	unladen	201 mm	232 mm	232 mm	237 mm
Overall length		5,124 mm	5,124 mm	5,124 mm	5,365 mm
Overall width		1,850 mm	1,850 mm	1,850 mm	1,850 mm
Overall height		1,703 mm	1,800 mm	1,804 mm	1,815 mm
Overhang	front	919 mm	919 mm	919 mm	919 mm
	rear	985 mm	985 mm	985 mm	1,234 mm
Track	front	1,590 mm	1,560 mm	1,560 mm	1,560 mm
	rear	1,590 mm	1,560 mm	1,560 mm	1,560 mm
Wading depth		600 mm	800 mm	800 mm	800 mm
Wheelbase		3,220 mm	3,220 mm	3,220 mm	3,220 mm
Approach angle		22.0°	27.6°	27.6°	27.6°
Departure angle		24.0°	28.4°	28.4°	27.1°
Ramp breakover angle		17.0°	24.4°	24.4°	24.4°

## CAB CHASSIS

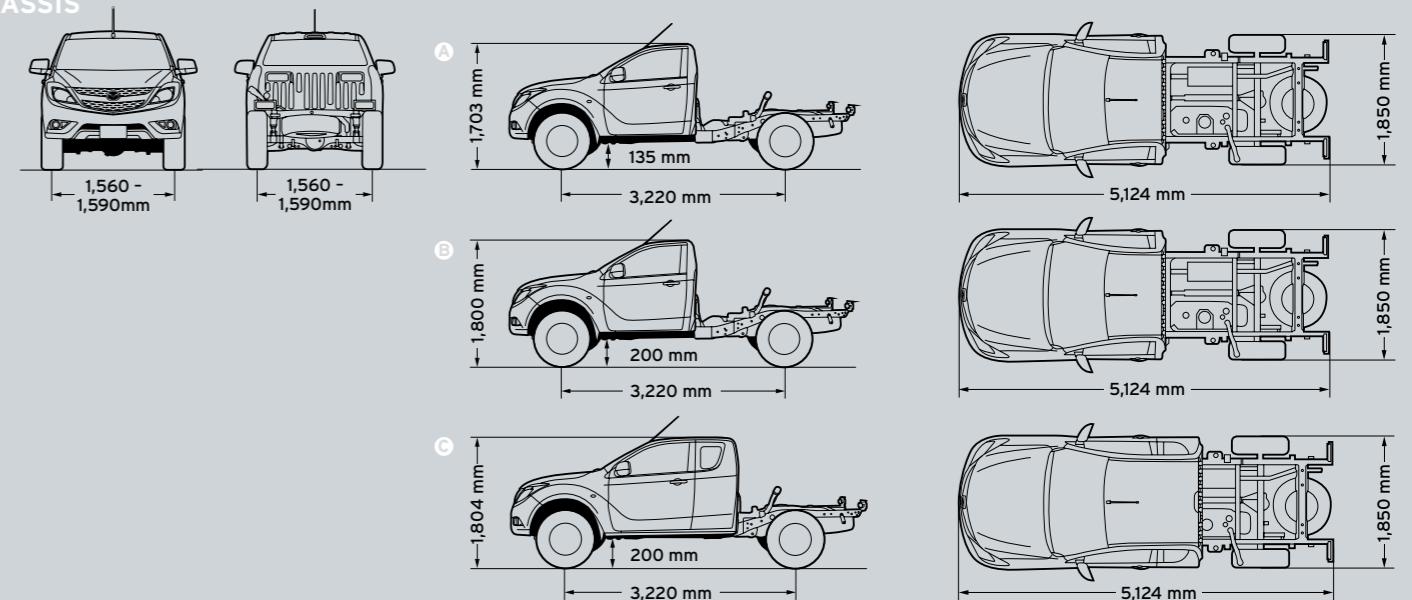

## UTILITY

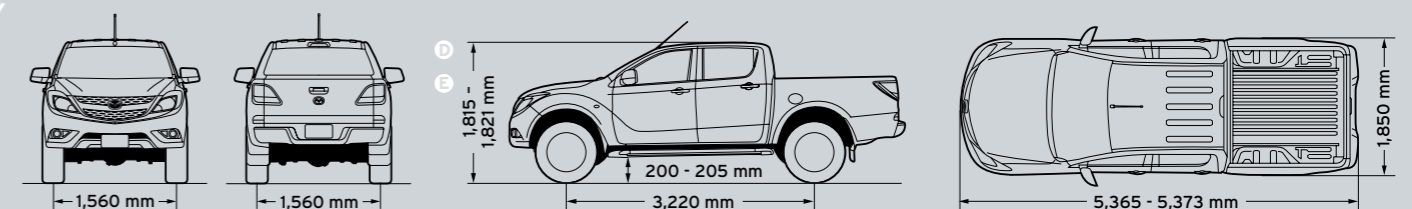

# 4x2 SPECIFICATIONS

	4x2 Single Cab Chassis XT	4x2 Single Cab Chassis XT Hi-Rider	4x2 Freestyle Cab Chassis XT Hi-Rider	4x2 Dual Cab Utility XT Hi-Rider	4x2 Dual Cab Utility XTR Hi-Rider
--	---------------------------	------------------------------------	---------------------------------------	----------------------------------	-----------------------------------

## Exterior

Cargo box features:	centre tailgate release (black)	-	-	-	●	-
	centre tailgate release (chrome)	-	-	-	-	●
	double wall construction	-	-	-	●	●
	interior rope hooks (6)	-	-	-	●	●
Door handles (black)	●	●	●	●	-	
Door handles (chrome)	-	-	-	-	●	
Fog-lamps (front)	-	-	-	-	●	
Freestyle door system	-	-	●	-	-	
Front bumper (body coloured)	●	●	●	●	●	
Fuel filler cap (lockable)	●	●	●	-	-	
Green tinted windscreen, side and rear windows	●	●	●	●	●	
Headlamps (halogen)	●	●	●	●	●	
Metallic/Mica paint	○	○	○	○	○	
Mudflaps (front)	●	●	●	●	●	
Mudflaps (rear)	-	-	-	●	●	
Power mirrors (black)	●	●	●	●	-	
Power mirrors (chrome)	-	-	-	-	●	
Power windows	●	●	●	●	●	
Rear step bumper (black)	-	-	-	●	-	
Rear step bumper (chrome)	-	-	-	-	●	
Side steps (aluminium finish)	-	-	-	-	●	

## Interior

Air-conditioning	●	●	●	●	-
Air-conditioning (dual-zone climate control)	-	-	-	-	●
Ambient temperature gauge	-	-	-	-	●
Auxiliary 12 volt power outlets	●	●	●	●	●
Bluetooth® (hands-free compatible) <sup>5</sup>	●	●	●	●	●
Centre armrest console with dual compartments	-	-	●	●	●
Critical function warning lights/chimes	●	●	●	●	●
Cruise control	●	●	●	●	●
Cupholders	●	●	●	●	●
Door pockets	●	●	●	●	●
Driver's left footrest	●	●	●	●	●
Floor covering:	carpet	-	-	-	●
	vinyl	●	●	●	●
Glove box	●	●	●	●	-
Glove box (lockable and illuminated)	-	-	-	-	●
Illuminated entry system with delayed fade	●	●	●	●	●
Instrument panel light dimmer	●	●	●	●	●
Interior illumination:	dome lamp	-	●	●	●
	map reading spot lamps	●	●	●	●
	power window switch (driver)	●	●	●	●
Leather-wrapped:	gear shift knob	-	-	-	●
	steering wheel	-	-	-	●
Low fuel warning light	●	●	●	●	●
Overhead sunglass storage box	●	●	●	●	●
Passenger assist grips	●	●	●	●	●
Satellite navigation	-	-	-	-	●
Seat trim:	cloth	●	●	●	●
Seat (driver's bucket) with:	adjustable head restraint	●	●	●	●
	height and lumbar adjustment	-	-	-	●
	rake and slide adjustment	●	●	●	●
Seat (passengers' front bench) with:	adjustable head restraint	●	●	-	-
	adjustable head restraint	-	-	●	●

	4x2 Single Cab Chassis XT	4x2 Single Cab Chassis XT Hi-Rider	4x2 Freestyle Cab Chassis XT Hi-Rider	4x2 Dual Cab Utility XT Hi-Rider	4x2 Dual Cab Utility XTR Hi-Rider
--	---------------------------	------------------------------------	---------------------------------------	----------------------------------	-----------------------------------

## Interior (continued)

Seat (passengers' front bucket) with:	rake and slide adjustment	-	-	●	●	●
	seat back pocket	-	-	●	●	●
Seat (passengers' rear bench) with:	adjustable head restraints	-	-	-	●	●
	foldable seat base and under-seat storage	-	-	-	●	●
Seat (passengers' rear jump) with:	removable seat base and under-seat storage	-	-	●	-	-
	Tachometer and electronic odometer/tripmeter	●	●	●	●	●
Tilt-adjustable steering wheel	●	●	●	●	●	
Trip computer (current and average fuel consumption, distance to empty and average vehicle speed)	●	●	●	●	●	
Vanity mirror (front passenger)	-	●	●	●	●	
Window demister (rear)	●	●	●	●	●	
Wipers (front) 2-speed with variable intermittent function	●	●	●	●	●	

## Audio

AM/FM tuner	●	●	●	●	●
Auxiliary input (3.5mm MP3 player compatible)	●	●	●	●	●
Bluetooth® audio (MP3 player compatible) <sup>5</sup>	●	●	●	●	●
CD player, single disc (MP3/WMA compatible)	●	●	●	●	●
Speakers (4)	●	●	●	-	-
Speakers (6)	-	-	-	●	●
Steering wheel-mounted audio controls	●	●	●	●	●
USB input (iPod compatible)	●	●	●	●	●

## Safety

Airbags SRS:	front (driver and passenger)	●	●	●	●	●
	side (front)	-	-	●	●	●
	curtain (front)	●	●	-	-	-
	curtain (front and rear)	-	-	●	●	●
Anti-lock Braking System (ABS)	●	●	●	●	●	
Child restraint anchor points (2)	-	-	●	●	●	
Childproof rear door locks	-	-	-	●	●	
Dynamic Stability Control (DSC) - switchable on/off	●	●	●	●	●	
Electronic Brake-force Distribution (EBD)	●	●	●	●	●	
Emergency Brake Assist (EBA)	●	●	●	●	●	
Engine immobiliser	●	●	●	●	●	
Emergency Stop Signal (ESS)	●	●	●	●	●	
High mount stop lamp	-	-	-	●	●	
Hill Launch Assist (HLA)	●	●	●	●	●	
Intrusion-minimising brake pedal	●	●	●	●	●	
Left-hand-side convex (wide angle) exterior mirror	●	●	●	●	●	
Load Adaptive Control (LAC)	●	●	●	●	●	
One touch (up and down) power window (driver)	●	●	●	●	●	
Remote central locking (2 transmitters with retractable key)	●	●	●	●	●	
Roll Stability Control (RSC)	●	●	●	●	●	
Seat-belt warning audible and visual (driver)	●	●	●	●	●	
Seat-belt warning audible and visual (front passenger)	-	-	●	●	●	
Seat-belts 3-point lap-sash (all seats)	●	●	●	●	●	
Seat-belts (front) with: height adjustable shoulder anchorages	-	-	-	●	●	
Seat-belts (front) with: pretensioners and load limiters	●	●	●	●	●	
Side impact door beams	●	●	●	●	●	
Traction Control System (TCS)	●	●	●	●	●	
Trailer Sway Control (TSC)	●	●	●	●	●	

# 4x4 SPECIFICATIONS

	4x4 Single Cab Chassis XT	4x4 Freestyle Cab Chassis XT	4x4 Freestyle Cab Utility XTR	4x4 Dual Cab Chassis XT	4x4 Dual Cab Utility XT	4x4 Dual Cab Utility XTR	4x4 Dual Cab Utility GT
--	---------------------------	------------------------------	-------------------------------	-------------------------	-------------------------	--------------------------	-------------------------

## Powertrain

Engine type	3.2 litre in-line 5 cylinder 20 valve DOHC intercooled turbo diesel						
Engine capacity	3,198 cc						
Bore and stroke	89.0 mm x 100.7 mm						
Compression ratio	15.5 : 1						
Maximum power	147 kW @ 3,000 rpm						
Maximum torque	470 Nm @ 1,750 – 2,500 rpm						
Throttle control	Electronic (drive-by-wire)						
Fuel system	Common-rail, electronic direct injection						
Fuel tank capacity	80 litres						
Recommended fuel	Diesel						
Fuel consumption <sup>1</sup>	man (combined)	8.9 litres per 100 km					
	auto (combined)	-	-	-	-	9.2 litres per 100 km	
Emissions standard	Euro stage IV						
Alternator	12 volts - 110 amps						
Manual transmission	6-speed						
Automatic transmission	-			6-speed			
Gear ratio - man/auto	1st	5.441 / -	5.441 / -	5.441 / -	5.441 / -	5.441 / 4.171	5.441 / 4.171
	2nd	2.839 / -	2.839 / -	2.839 / -	2.839 / -	2.839 / 2.342	2.839 / 2.342
	3rd	1.721 / -	1.721 / -	1.721 / -	1.721 / -	1.721 / 1.521	1.721 / 1.521
	4th	1.223 / -	1.223 / -	1.223 / -	1.223 / -	1.223 / 1.143	1.223 / 1.143
	5th	1.000 / -	1.000 / -	1.000 / -	1.000 / -	1.000 / 0.867	1.000 / 0.867
	6th	0.794 / -	0.794 / -	0.794 / -	0.794 / -	0.794 / 0.691	0.794 / 0.691
	reverse	4.935 / -	4.935 / -	4.935 / -	4.935 / -	4.935 / 3.403	4.935 / 3.403
	final drive	3.550 / -	3.550 / -	3.550 / -	3.550 / -	3.550 / 3.730	3.550 / 3.730
Transfer gear	high	1.000	1.000	1.000	1.000	1.000	1.000
	low	2.718	2.718	2.718	2.718	2.718	2.718

## Chassis

Brake diameter	front	302 mm					
	rear	295 mm					
Brake type	front	Ventilated disc					
	rear	Drum					
Steering type	Rack and pinion hydraulic power assist steering						
Suspension type	front	Independent double wishbone with coil over dampers and anti-roll bar					
	rear	Rigid (live) rear axle with leaf springs					
Turning circle	kerb to kerb	12.4 m					
Tyre size		255/70 R16	255/70 R16	265/65 R17	255/70 R16	255/70 R16	265/65 R17
Tyre index		111T	111T	112T	111T	111T	112T
Wheel size		16 x 7.0 J	16 x 7.0 J	17 x 8.0 J	16 x 7.0 J	16 x 7.0 J	17 x 8.0 J
Wheel type		Steel	Steel	Alloy	Steel	Steel	Alloy
Wheel size (spare)		16 x 7.0 J	16 x 7.0 J	17 x 7.5 J	16 x 7.0 J	16 x 7.0 J	17 x 7.5 J
Wheel type (spare)		Steel	Steel	Steel	Steel	Steel	Steel

## Weights and Capacities

Axle capacity	front	1,480 kg	1,480 kg	1,480 kg	1,480 kg	1,480 kg	1,480 kg
	rear	1,850 kg	1,850 kg	1,850 kg	1,850 kg	1,850 kg	1,850 kg
Gross Combined Mass (GCM) <sup>2</sup>	man	5,950 kg	5,950 kg	5,950 kg	5,950 kg	5,950 kg	5,950 kg
	auto	-	-	-	-	5,950 kg	5,950 kg
Gross Vehicle Mass (GVM)	man	3,200 kg	3,200 kg	3,200 kg	3,200 kg	3,200 kg	3,200 kg
	auto	-	-	-	-	3,200 kg	3,200 kg
Kerb weight	man	1,789 kg	1,857 kg	2,037 kg	1,929 kg	2,044 kg	2,095 kg
	auto	-	-	-	-	2,061 kg	2,112 kg
Payload <sup>3</sup>	man	1,411 kg	1,343 kg	1,163 kg	1,271 kg	1,156 kg	1,105 kg
	auto	-	-	-	-	1,139 kg	1,088 kg
Seating capacity		3	4	4	5	5	5
Tow ball download	maximum	335 kg	335 kg	335 kg	335 kg	335 kg	335 kg
Towing capacity <sup>4</sup>	braked	3,350 kg	3,350 kg	3,350 kg	3,350 kg	3,350 kg	3,350 kg
	unbraked	750 kg	750 kg	750 kg	750 kg	750 kg	750 kg

	A 4x4 Single Cab Chassis XT	B 4x4 Freestyle Cab Chassis XT	C 4x4 Freestyle Cab Utility XTR	D 4x4 Dual Cab Chassis XT	E 4x4 Dual Cab Utility XT	F 4x4 Dual Cab Utility XTR	G 4x4 Dual Cab Utility GT
--	--------------------------------	-----------------------------------	------------------------------------	------------------------------	------------------------------	-------------------------------	------------------------------

## Dimensions

Cargo box floor height to ground	-	-	835 mm	-	835 mm	841 mm	841 mm
Cargo box floor length	-	-	1,847 mm	-	1,549 mm	1,549 mm	1,549 mm
Cargo box floor width	-	-	1,560 mm	-	1,560 mm	1,560 mm	1,560 mm
Cargo box height	-	-	513 mm	-	513 mm	513 mm	513 mm
Cargo box tailgate opening width	-	-	1,330 mm	-	1,330 mm	1,330 mm	1,330 mm
Cargo box top length	-	-	1,783 mm	-	1,485 mm	1,485 mm	1,485 mm
Cargo box top width	-	-	1,500 mm	-	1,500 mm	1,500 mm	1,500 mm
Cargo box width between wheel arches	-	-	1,139 mm	-	1,139 mm	1,139 mm	1,139 mm
Ground clearance	laden	200 mm	200 mm	205 mm	200 mm	205 mm	205 mm
	unladen	232 mm	232 mm	237 mm	232 mm	237 mm	237 mm
Overall length		5,124 mm	5,124 mm	5,365 mm	5,124 mm	5,373 mm	5,365 mm
Overall width		1,850 mm	1,850 mm	1,850 mm	1,850 mm	1,850 mm	1,850 mm
Overall height		1,800 mm	1,804 mm	1,810 mm	1,815 mm	1,815 mm	1,821 mm
Overhang	front	919 mm	919 mm	919 mm	919 mm	919 mm	919 mm
	rear	985 mm	985 mm	1,226 mm	985 mm	1,234 mm	1,226 mm
Track	front	1,560 mm	1,560 mm	1,560 mm	1,560 mm	1,560 mm	1,560 mm
	rear	1,560 mm	1,560 mm	1,560 mm	1,560 mm	1,560 mm	1,560 mm
Wading depth		800 mm	800 mm	800 mm	800 mm	800 mm	800 mm
Wheelbase		3,220 mm	3,220 mm	3,220 mm	3,220 mm	3,220 mm	3,220 mm
Approach angle		27.6°	27.6°	28.2°	27.6°	28.2°	28.2°
Departure angle		28.4°	28.4°	26.4°	28.4°	26.4°	26.4°
Ramp breakover angle		24.4°	24.4°	25.0°	24.4°	25.0°	25.0°

## CAB CHASSIS

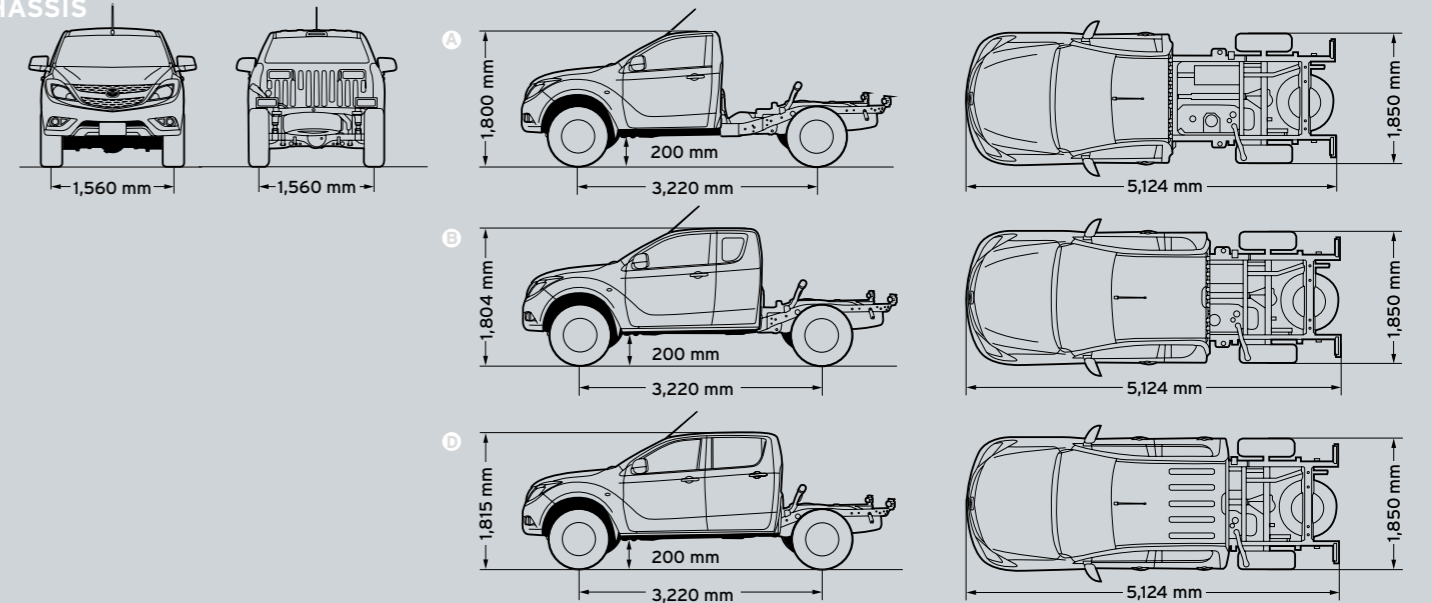

## UTILITY

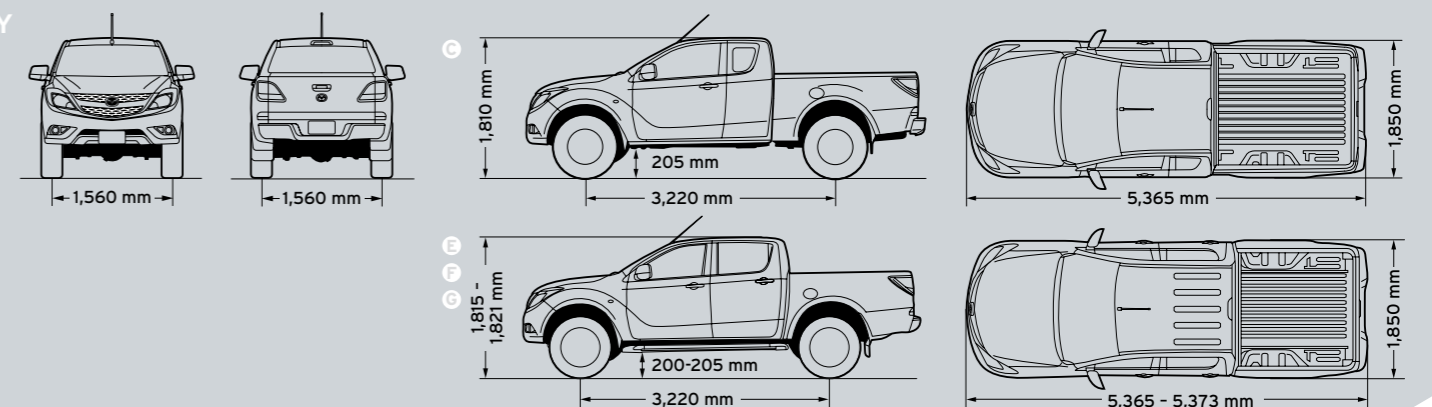

● Standard Feature - Not Available ○ No Cost Option



# 4x4 SPECIFICATIONS

	4x4 Single Cab Chassis XT	4x4 Freestyle Cab Chassis XT	4x4 Freestyle Cab Utility XTR	4x4 Dual Cab Chassis XT	4x4 Dual Cab Utility XT	4x4 Dual Cab Utility XTR	4x4 Dual Cab Utility GT
--	---------------------------	------------------------------	-------------------------------	-------------------------	-------------------------	--------------------------	-------------------------

## Exterior

Cargo box features:	centre tailgate release (black)	-	-	-	-	●	-
	centre tailgate release (chrome)	-	-	●	-	-	●
	double wall construction	-	-	●	-	●	●
	interior rope hooks (6)	-	-	●	-	●	●
Door handles (black)	●	●	-	●	●	-	-
Door handles (chrome)	-	-	●	-	-	●	●
Fog-lamps (front)	-	-	●	-	-	●	●
Freestyle door system	-	●	●	-	-	-	-
Front bumper (body coloured)	●	●	●	●	●	●	●
Fuel filler cap (lockable)	●	●	-	●	-	-	-
Green tinted windscreen, side and rear windows	●	●	●	●	●	●	●
Headlamps (halogen)	●	●	●	●	●	●	●
Metallic/Mica paint	○	○	○	○	○	○	○
Mudflaps (front)	●	●	●	●	●	●	●
Mudflaps (rear)	-	-	●	-	●	●	●
Power mirrors (black)	●	●	-	●	●	-	-
Power mirrors (chrome)	-	-	●	-	-	●	●
Power windows	●	●	●	●	●	●	●
Rear step bumper (black)	-	-	-	-	●	-	-
Rear step bumper (chrome)	-	-	●	-	-	●	●
Side steps (aluminium finish)	-	-	●	-	-	●	●
Under-body impact protection	●	●	●	●	●	●	●

## Interior

Air-conditioning	●	●	-	●	●	-	-
Air-conditioning (dual-zone climate control)	-	-	●	-	-	●	●
Ambient temperature gauge	-	-	●	-	-	●	●
Auxiliary 12 volt power outlets	●	●	●	●	●	●	●
Bluetooth® (hands-free compatible) <sup>5</sup>	●	●	●	●	●	●	●
Centre armrest console with dual compartments	-	●	●	●	●	●	●
Critical function warning lights/chimes	●	●	●	●	●	●	●
Cruise control	●	●	●	●	●	●	●
Cupholders	●	●	●	●	●	●	●
Door pockets	●	●	●	●	●	●	●
Driver's left footrest	●	●	●	●	●	●	●
Floor covering:	carpet	-	●	-	-	●	●
	vinyl	●	●	-	●	-	-
Glove box	●	●	-	●	●	-	-
Glove box (lockable and illuminated)	-	-	●	-	-	●	●
Headlamps auto on/off function	-	-	-	-	-	-	●
Illuminated entry system with delayed fade	●	●	●	●	●	●	●
Instrument panel light dimmer	●	●	●	●	●	●	●
Interior illumination:	dome lamp	-	●	●	●	●	●
	map reading spot lamps	●	●	●	●	●	●
	power window switch (driver)	●	●	●	●	●	●
Leather-wrapped:	gear shift knob	-	-	●	-	-	●
	steering wheel	-	-	●	-	-	●
Low fuel warning light	●	●	●	●	●	●	●
Overhead sunglasses storage box	●	●	●	●	●	●	●
Passenger assist grips	●	●	●	●	●	●	●
Rear-view mirror with auto dimming function	-	-	-	-	-	-	●
Satellite navigation	-	-	●	-	-	●	●
Seat trim:	cloth	●	●	●	●	●	-
	leather <sup>6</sup>	-	-	-	-	-	●
Seat (driver's bucket) with:	adjustable head restraint	●	●	●	●	●	●
	height and lumbar adjustment	-	-	●	-	-	●
	rake and slide adjustment	●	●	●	●	●	●
Seat (passengers' front bench) with:	adjustable head restraint	●	-	-	-	-	-

	4x4 Single Cab Chassis XT	4x4 Freestyle Cab Chassis XT	4x4 Freestyle Cab Utility XTR	4x4 Dual Cab Chassis XT	4x4 Dual Cab Utility XT	4x4 Dual Cab Utility XTR	4x4 Dual Cab Utility GT
--	---------------------------	------------------------------	-------------------------------	-------------------------	-------------------------	--------------------------	-------------------------

## Interior (continued)

Seat (passengers' front bucket) with:	adjustable head restraint	-	●	●	●	●	●
	rake and slide adjustment	-	●	●	●	●	●
	seat back pocket	-	●	●	●	●	●
Seat (passengers' rear bench) with:	adjustable head restraints	-	-	-	●	●	●
	foldable seat base and under-seat storage	-	-	-	●	●	●
Seat (passengers' rear jump) with:	removable seat base and under-seat storage	-	●	●	-	-	-
Tachometer and electronic odometer/tripmeter	●	●	●	●	●	●	●
Tilt-adjustable steering wheel	●	●	●	●	●	●	●
Trip computer (current and average fuel consumption, distance to empty and average vehicle speed)	●	●	●	●	●	●	●
Vanity mirror (front passenger)	●	●	●	●	●	●	●
Window demister (rear)	●	●	●	●	●	●	●
Wipers (front) 2-speed with rain-sensing function	-	-	-	-	-	-	●
Wipers (front) 2-speed with variable intermittent function	●	●	●	●	●	●	-

## Audio

AM/FM tuner	●	●	●	●	●	●	●
Auxiliary input (3.5mm MP3 player compatible)	●	●	●	●	●	●	●
Bluetooth® audio (MP3 player compatible) <sup>5</sup>	●	●	●	●	●	●	●
CD player, single disc (MP3/WMA compatible)	●	●	●	●	●	●	●
Speakers (4)	●	●	●	-	-	-	-
Speakers (6)	-	-	-	●	●	●	●
Steering wheel-mounted audio controls	●	●	●	●	●	●	●
USB input (iPod compatible)	●	●	●	●	●	●	●

## Safety

Airbags SRS:	front (driver and passenger)	●	●	●	●	●	●
	side (front)	-	●	●	●	●	●
	curtain (front)	●	-	-	-	-	-
	curtain (front and rear)	-	●	●	●	●	●
Anti-lock Braking System (ABS)	●	●	●	●	●	●	●
Child restraint anchor points (2)	-	●	●	●	●	●	●
Childproof rear door locks	-	-	-	●	●	●	●
Dynamic Stability Control (DSC) - switchable on/off	●	●	●	●	●	●	●
Electronic Brake-force Distribution (EBD)	●	●	●	●	●	●	●
Emergency Brake Assist (EBA)	●	●	●	●	●	●	●
Engine immobiliser	●	●	●	●	●	●	●
Emergency Stop Signal (ESS)	●	●	●	●	●	●	●
High mount stop lamp	-	-	●	-	-	●	●
Hill Descent Control (HDC)	●	●	●	●	●	●	●
Hill Launch Assist (HLA)	●	●	●	●	●	●	●
Intrusion-minimising brake pedal	●	●	●	●	●	●	●
Left-hand-side convex (wide angle) exterior mirror	●	●	●	●	●	●	●
Load Adaptive Control (LAC)	●	●	●	●	●	●	●
Locking Rear Differential (LRD) - switchable on/off	●	●	●	●	●	●	●
One touch (up and down) power window (driver)	●	●	●	●	●	●	●
Remote central locking (2 transmitters with retractable key)	●	●	●	●	●	●	●
Roll Stability Control (RSC)	●	●	●	●	●	●	●
Seat-belt warning audible and visual (driver)	●	●	●	●	●	●	●
Seat-belt warning audible and visual (front passenger)	-	●	●	●	●	●	●
Seat-belts 3-point lap-sash (all seats)	●	●	●	●	●	●	●
Seat-belts (front) with: height adjustable shoulder anchorages	-	-	-	●	●	●	●
Seat-belts (front) with: pretensioners and load limiters	●	●	●	●	●	●	●
Side impact door beams	●	●	●	●	●	●	●
Traction Control System (TCS)	●	●	●	●	●	●	●
Trailer Sway Control (TSC)	●	●	●	●	●	●	●

● Standard Feature - Not Available ○ No Cost Option



# Mazda BT-50 ACCESSORIES

ZOOM-ZOOM

## MAKE YOUR Mazda EVEN MORE REWARDING

Mazda BT-50 combines amazing versatility with refined design and durability. And with Mazda Genuine Accessories, owning one becomes even more satisfying. They let you personalise your vehicle and protect your investment. They also deliver superb design, quality, fit and safety. With Mazda Genuine Accessories you get to add even more Zoom-Zoom.



**Weathershields (right or left hand front)**  
Let fresh air into the cabin, but not the weather.



**Collapsible sun screen**  
Keep your vehicle cool and protect the interior from the sun's harmful rays.



**Carpet floor mats (set of two or four)**  
Stylish and durable tailor-made mats. Driver's side mat incorporates a heel pad.



[PLAY VIDEO](#)

**12 volt auxiliary sockets**  
Contains two 15 amp sockets to provide power to small electrical items. (Utilities only.)

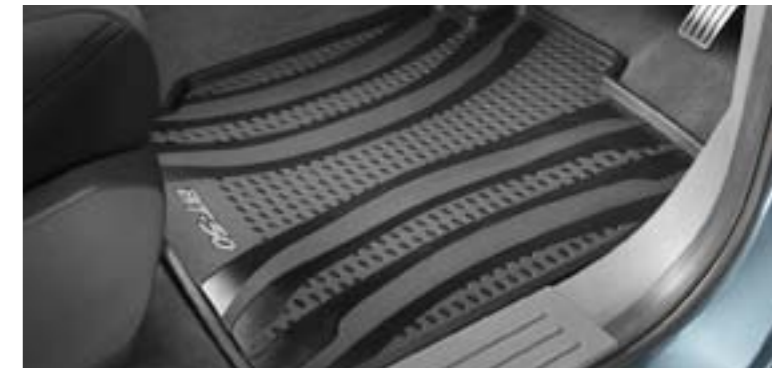

**Rubber floor mats (set of two or four)**  
Heavy duty tailor-made mats.



**Seat cover (front)**  
Made from durable, waterproof neoprene material, these airbag compatible covers keep your seats free from dirt and grime.



**Seat covers (rear)**  
A lightweight, waterproof cover that shields the rear seats from spills, dirt, pet scratches and everyday wear and tear. (Dual Cab only.)





PLAY VIDEO

**Rear parking camera and auto-dimming rear view mirror**

Provides added awareness to make reverse parking easier. Overlaid screen guides assist parking, auto-dimming function reduces glare.



**Reverse parking sensors**

Advanced sensors use warning tone to make parking easier, even with a tow bar. (Utilities only.)



**Fog-lamps**

Enjoy improved visibility in conditions such as fog, rain and snow.



**Bonnet and headlight protectors**

Prevent costly damage from stones and other debris.



**Tray mat**

Non-slip surface protects your utility's tray from marks and scratches. (Utilities only.)



PLAY VIDEO

**Tie down rails and straps**

Secure loads with convenience and confidence. Includes two rails, four tie downs and two straps per kit. (Dual Cab Utilities only.)



PLAY VIDEO

**Rear seat entertainment holder - for iPad**

Keep rear seat passengers entertained with this convenient holder for your iPad (includes set of headphones).



**Auto interface cable - for iPod**

Stream music and track data from your iPod to the vehicle's audio system and multi information display.



PLAY VIDEO

**UHF radio**

Stay connected and safe in remote areas with this reliable 80 channel UHF radio unit.



PLAY VIDEO

**Recovery kit**

The Mazda Genuine recovery kit has everything you need to recover your vehicle should you become bogged or stuck. Kit includes: snatch strap, tree trunk protector strap, winch extension strap, snatch block, bow shackles x2, recovery blanket, heavy duty gloves, bag. (Hand winch and air compressor sold separately.)

**Also available**

- ▶ Alloy wheel 16 inch - 5-spoke
- ▶ Ashtray and cigarette lighter
- ▶ Bonnet protector (smoke)
- ▶ Canopy auto interior light
- ▶ Canopy roof racks
- ▶ Dual battery pack
- ▶ Ladder rack for sports bar (black) (Utilities only)
- ▶ Lighforce Genesis driving light filters (Spot Clear, Combo Clear, Wide Clear, Spot Crystal Blue, Combo Crystal Blue or Wide Crystal Blue)
- ▶ Load leveller
- ▶ Rear recovery point
- ▶ Remote keyless entry for hard tonneau cover
- ▶ Slimline weathershields (front set)
- ▶ Slimline weathershields (set of four)
- ▶ Snorkel
- ▶ Tow ball
- ▶ Tow ball cover
- ▶ Trailer wiring harness
- ▶ Tub and tailgate liner (Utilities only)

**Mazda Bluetooth® audio transmitter - for iPod**

Wireless adaptor allows iPod to be played through the vehicle's audio system. Includes 12V power adaptor that charges your iPod as you drive.



PLAY VIDEO

**Tow bar**

Designed specifically for BT-50, with a 3,350kg towing capacity and 335kg tow ball download capacity\* (3.2L models) or 2,500kg towing capacity and 250kg tow ball download capacity\* (2.2L model).



Tow ball and wiring loom sold separately. \*Subject to State or Territory regulations. Please refer to your Mazda Dealer for further information.

**Alarm system (hi-spec)**

Provides enhanced security and peace of mind. Includes dual zone tub protection sensors.



PLAY VIDEO

**Auto lights on/off**

Monitors outside light levels and turns headlights on or off accordingly.



To see the full range of Mazda Genuine Accessories, go to [Mazda.COM.AU](http://Mazda.COM.AU)

All care is taken to ensure the accuracy of this brochure at the time of publication. Equipment shown in the brochure is for illustrative purposes only and does not come standard with the vehicle, or as Mazda Genuine Accessories. Specifications, features and availability may vary from State to State and may change without notice. Please refer to [mazda.com.au](http://mazda.com.au) or consult your Mazda Dealer prior to placing an order to ascertain current information on availability, specifications, features and prices. Mazda Australia Pty Limited will not be liable for any loss arising from the information in this brochure, whether in negligence or otherwise. Mazda Australia Pty Limited ABN 78 004 690 804, 385 Ferntree Gully Road, Mount Waverley, Victoria 3149. Mazda Genuine Accessories fitted at the point of sale of a new Mazda BT-50 are covered under the Mazda 3-year or 100,000 kilometre (whichever should occur first) or 2-year unlimited kilometre warranty. Mazda Genuine Accessories fitted after the sale of a new Mazda vehicle are covered by the Mazda 2-year or 40,000 kilometre warranty (whichever should occur first). iPod and iPad are trademarks of Apple Inc., registered in the U.S. and other countries. Please check the compatibility of your Bluetooth® device (particularly your mobile phone) with the specific Bluetooth® accessory you intend to purchase as not all devices will operate correctly. Consult your Mazda Dealer for further information. Published November 2011. MAZ9939 126.029



**Nudge bar (polished)**  
Give the front of your BT-50 a tougher look. Incorporates mounts for optional Lightforce driving lights.



**Nudge bar (black)**



[PLAY VIDEO](#)

**Lockable tool box (steel)**  
Lockable tool box helps you keep equipment organised and secure. Can be mounted to either side of the vehicle in a choice of four locations. (Dual Cab Utilities only.)



**Lockable tool box (steel mesh)**



**Bull bar (black)**  
Airbag-compatible and built tough. Designed specifically for BT-50, this Mazda Genuine bull bar meets our stringent standards.  
[PLAY VIDEO](#)

**Lightforce driving lights**  
Powerful beams help you work or play after dark.

**Sports bar (black)**  
A great looking accessory that integrates an LED high mount stop lamp. (Utilities only.)

**Soft tonneau cover**  
Durable cover available for vehicles with or without sports bar. (Utilities only.)

**17 inch rims (5-spoke)**  
Give your BT-50 a more sporting footprint with this design.

**Side steps (black)**  
The easier way to get in and out. Airbag compatible. (Freestyle and Dual Cabs only.)



**Hard tonneau cover**

Strong, streamlined design is lockable for added security. Available for vehicles with or without sports bar. (Dual Cab Utilities only.)

**Bull bar (aluminium)**

Airbag-compatible and built tough. Designed specifically for BT-50, this Mazda Genuine bull bar meets our stringent standards.

[PLAY VIDEO](#)



**17 inch rims (7-spoke)**

Give your BT-50 a more sporting footprint with this design. (XTR and GT models only.)

**Side steps (polished)**

The easier way to get in and out. Airbag compatible. (Freestyle and Dual Cabs only.)

**Lightforce driving lights**

Powerful beams help you work or play after dark.



**Soft tonneau cover**

Durable cover available for vehicles with or without sports bar. (Utilities only.)



**Sports bar (polished)**

A tough, stylish accessory with an integrated LED high mount stop lamp. (Utilities only.)



**Sports bar (black)**

(Utilities only.)



**Ladder rack for sports bar (polished)**

Makes carrying ladders and other long items straight forward. Load capacity up to 75kg. (Utilities only.)



[PLAY VIDEO](#)

**Canopy**

Attractive and secure in tough ABS plastic. Lockable rear door lifts for easy access to generous storage. (Dual Cab Utilities only.)