

ALL NEW ... A LEAP  
AHEAD IN VALUE!

**HOLDEN**  
**UTILITY**  
AND  
**PANEL**  
**VAN**

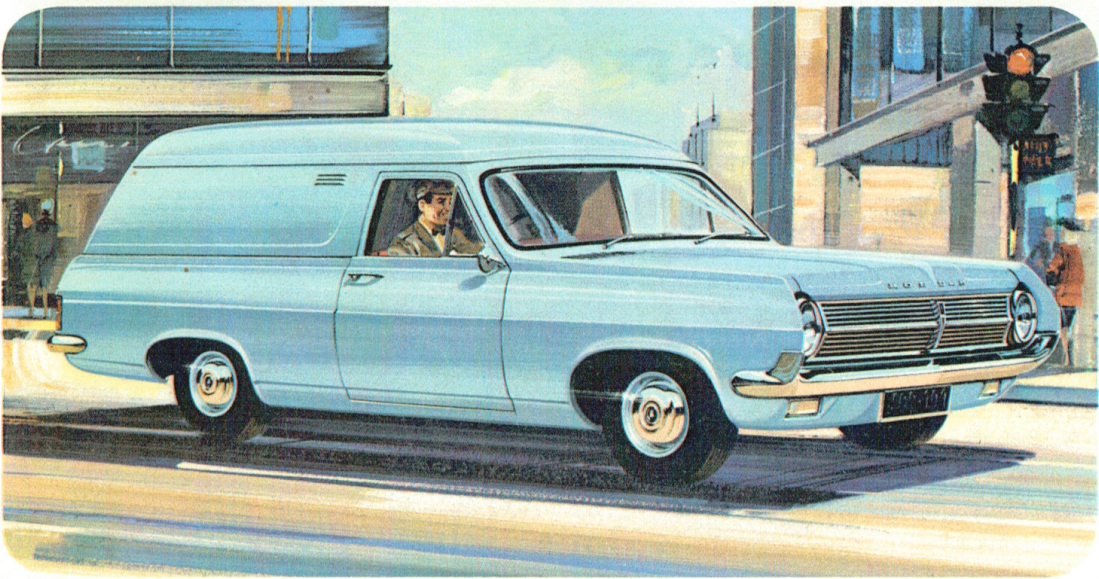



HOLDEN HALF-TON UTILITY





# Years-ahead new looks, more room, more load space, new cost-cutting features!

When you look over the all-new Holden half-ton Utility and drive it, it will take you just five minutes and as many miles to discover it's got the combination of **everything** you want in a vehicle that's made for work! Holden's curved styling, with its curved doors and windows, smart new grille and wrap-around bumpers, is all-new and years ahead. Holden's good looks reflect the go-ahead attitude of the organisation or man who operates it. (And it's handsome company on social occasions, too!)

Inside, Holden is equally good-looking. Instrument panel and steering wheel have been completely restyled. Rich, new-design Elascofab upholstery on the wider bench seat has the quality you'd expect to find in a sedan. There's provision for tailor-made extras such as radio and heater. But the real surprise comes when you're seated. Holden's new curved doors and windows give you an extra 5 inches of shoulder room. And with the engine moved 3 in. further forward there's extra

legroom, too. This makes Holden the **roomiest** ute you can buy!

The spacious new load compartment is much wider, and almost 4 inches longer. There's more room for bulky cargo, extra space for profitable loads, and a load capacity of half a ton including driver. What's more, the tailgate opening is **over 6 inches wider** — the widest in its class. This allows you to carry building materials, for example, up to 4 ft. wide.

With the tailgate down, you've a clear 8 ft. 3 in. to support long loads . . . and real structural strength to go with it. Only Holden has durable 'Double Life' body construction — an all-steel panel which extends the full length of the cargo area, right to the tailgate, plus a load floor of laminated hardwood.

When it comes to horsepower, Holden's got just what you want — a choice of three great engines, each with the blend of rugged power and economy you need: 100-hp '149', 115-hp '179' and the fiery 140-hp 'X2'. Match the one you choose to manual

transmission or the option of smooth new Powerglide automatic transmission.

Listed in this catalogue you'll find an array of new features that puts Holden even further ahead in low-cost operation. This includes changes to the front suspension that reduce lubrication intervals to 6000 miles or six months.

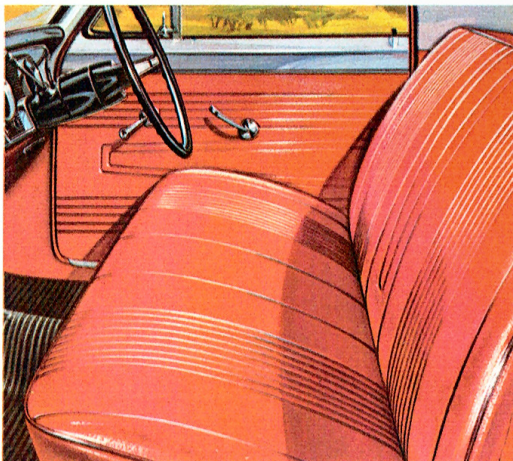

Holden's big brakes, with 140 sq. in. of lining area, adjust automatically. Optional at moderate cost: new power-assisted front wheel disc brakes, ideal under heavy working conditions. A new alternator-type generator extends battery life with more even power output.

New front fender inner panels are great in rough country —

they stop mud build-up, are easy to clean and reduce the corrosion which can result.

In addition to these new features, Holden offers a range of useful and convenient items which are

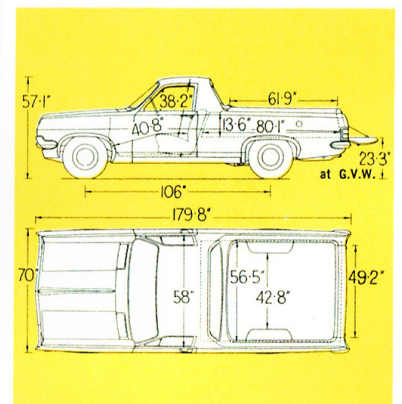

standard equipment, such as 2-speed electric windshield wipers and a weatherproof tonneau cover.

Add up the extra savings you're going to make with Holden, take into account its tradition of proved reliability and consistently higher resale value, and you've got a business proposition that makes **real** sense. No doubt about it — Holden half-ton Utility is a **leap** ahead in value!



HOLDEN PANEL VAN

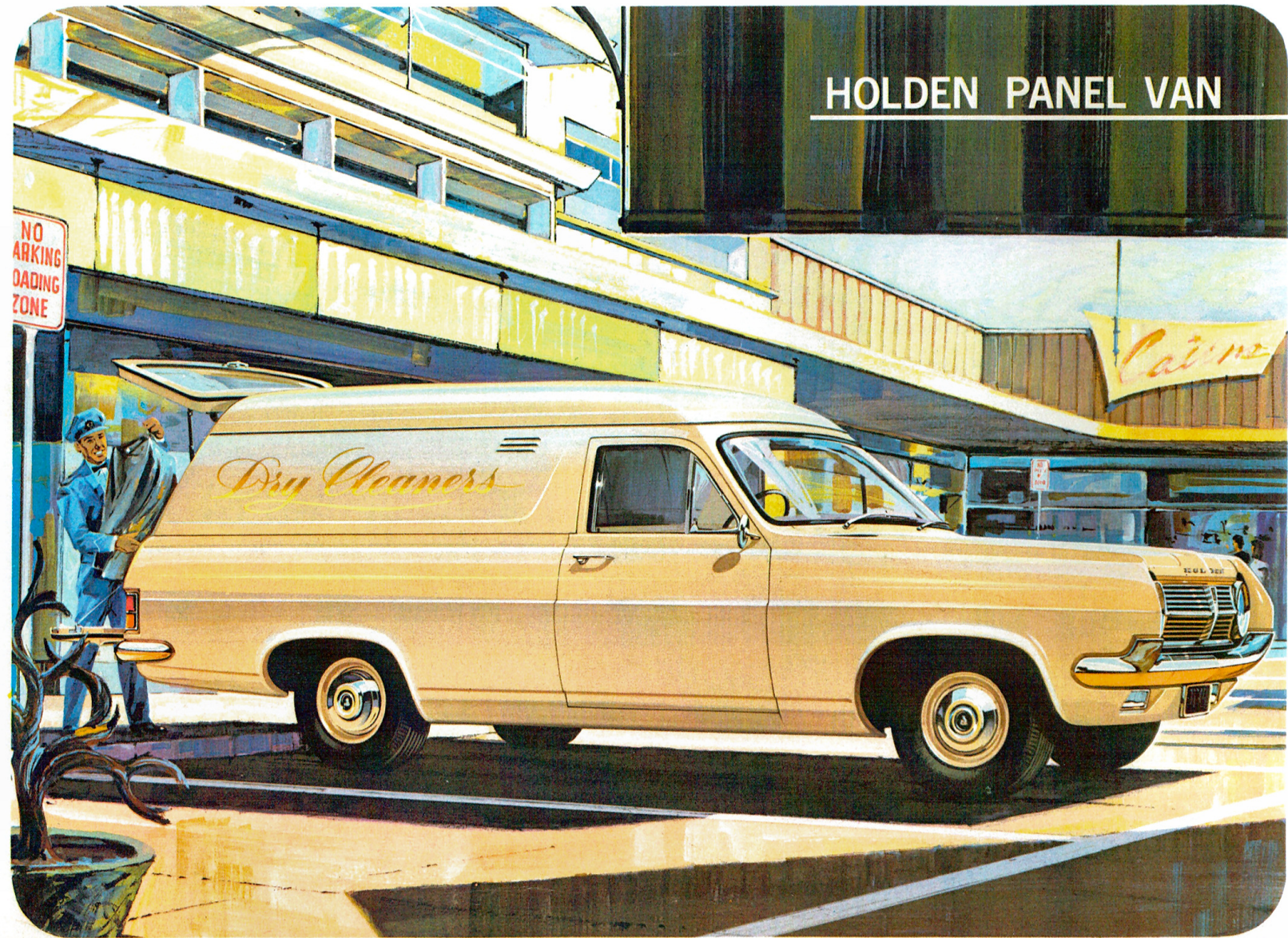



# More cargo space, extra sedan comfort, and new style that's good for business!

With its years-ahead curved styling, the all-new Holden half-ton Panel Van is much better looking than any van you've ever put your company name on. And when you see how much extra cargo space and passenger room it offers now, it looks even better!

Inside that new, deep-crown roof is 84½ cubic ft. of fully usable space 3 ft. 4 in. high. New curved side walls and a new tailgate that's over 6 in. wider now make it possible to load bulky items up to 4 ft. wide. (Those sides are useful outside, too—as large billboards, signwritten with your business name and message.)

Drop Holden's tailgate down, and there's a flat deck 8 ft. 4 in. long. By simply detaching the flexible steel limit cables on the tailgate and dropping the gate all the way, you can back right up against any loading bay.

Up front Holden offers a degree of comfort you've never before experienced in a vehicle of its

kind. There's extra stretch-out room for three (5 in. more shoulder room) plus more hip-room, and a new **flatter floor that makes more legroom**. The instrument panel is completely new, sponge-padded across the top for safety.

You'll notice the new windshield—it's 103 sq. in. larger for better visibility. Standard equipment includes such items as two-speed electric windshield wipers, sun-visor, seat-belt anchor points, and smoothly fitting rubber floor mats. Extra-easy Power steering comes as a low-cost option.

And Holden is now better equipped than any van of its type to get your operating costs down to bedrock. All three engines have a rugged seven-bearing crankshaft for smoothness and long engine life, also hydraulic valve-lifters which don't require periodic adjustment. Changes to the front suspension reduce lubrication intervals to 6000 miles or 6 months. A new exhaust muffler has aluminised components for

extra corrosion resistance. A new alternator extends battery life because it charges even at idling speed.

And because Holden is the only panel van designed specifically for Australian conditions, it

gives you the year-in, year-out reliability that adds up to big savings. You see this dependability in the way Holden's 'Double Life' body construction stands up to tough roads and loads. Same goes for Holden's

rugged suspension. With its big front coil springs and massive cross-member, and long, tough rear springs, it's proved time and again it's unbeatable.

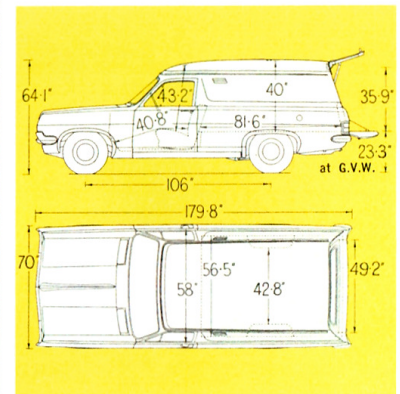
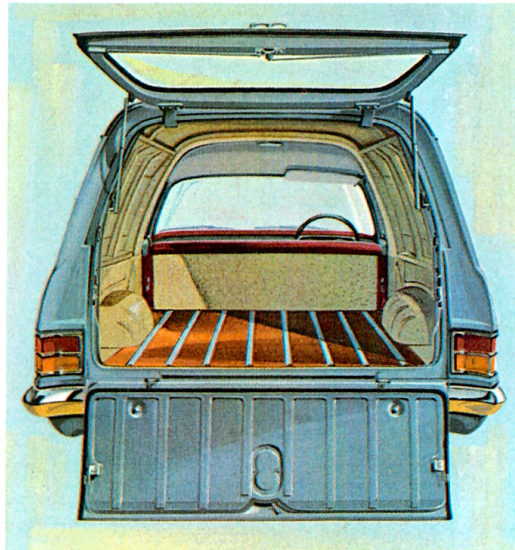

Holden's gem-hard 'Magic-Mirror' acrylic lacquer keeps its showroom gloss longer, protects your investment better until resale time comes round. And when it does come round, you'll find Holden gives you unmatched resale value!

Extra cargo space, extra comfort and new operating economy . . . you get them all, plus great new style, in the all-new Holden Panel Van—your best buy ever!



# 3 tough engines, 2 rugged transmissions, big self-adjusting brakes!

## 100-HP '149'

The '149' engine, standard on Holden Utility and Panel Van, and its stablemates the '179' and 'X2' are designed specifically for Australian conditions. They're the only utility engines that offer you the combination of a seven-bearing crankshaft for longer life and smoother running, plus quiet hydraulic valve-lifters that put an end to tappet noise.

With an 8.8 to 1 compression ratio and highly efficient

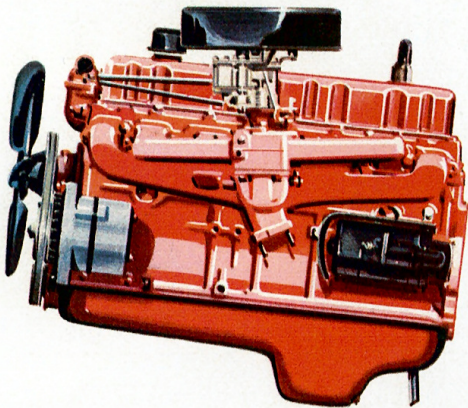

wedge-shaped combustion chamber design, the '149' gives you lively six-cylinder power with remarkable fuel economy over a wide range of operating conditions.

## 115-HP '179'

The big '179', optional at moderate extra cost, offers an extra margin of performance when special needs call for it, with the reliability that has been proved by hundreds of thousands of owners.

## 140-HP 'X2'

The optional fiery 140-hp 'X2' gives you slingshot acceleration from twin carburetors, new high-lift camshaft, new inlet and exhaust manifolds, plus a low-restriction exhaust system.



### CHOICE OF TRANSMISSIONS

Holden engines can be matched to the transmission that's right for you: a work-proved three-speed gearbox with all gears hardened by a carburising process for maximum reliability,

or smooth new Powerglide automatic transmission. Powerglide, an optional extra, has been specially developed for Holden from the reliable unit fitted to more vehicles throughout the world than any other automatic. It offers the ultimate in fatigue-free driving, particularly if you operate a utility or panel van in stop-and-go traffic. All gear-changing is done for you, automatically, swiftly, silently.

For extra punch and safe passing, Powerglide has a low gear which can be summoned instantly by extra pressure on the accelerator. For engine braking on steep hills, you can select 'Low' manually with the steering column selector lever. An inbuilt parking lock is incorporated. Compact design and light weight, plus the simplicity of Powerglide's operation, assure you of excellent fuel economy.

### BIG, HEAVY-DUTY BRAKES

Holden's big brakes—with a massive 140 sq. ins. of lining area—give you sure stops and exceptional resistance to fading.

Ideal under tough, hard-working conditions, optional power-assisted front wheel disc brakes are sure, safe, fade-free.

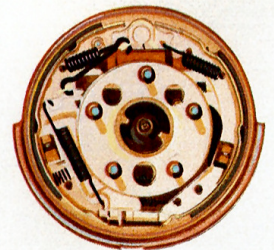



# New Holden features for maximum life, minimum maintenance . . .

With a combination of proven features and a host of new ones, the new Holden Utility and Panel Van are more ruggedly built and better equipped for low-cost operation than ever:



**'DOUBLE LIFE' BODY CONSTRUCTION**, exclusive to Holden, makes your utility or panel van the strongest you can buy. For example, there's a double floor in the load compartment — an all-steel panel, topped by a replaceable floor of laminated hardwood protected by steel skid strips.

**NEW FRONT FENDER INNER PANELS** have smooth contours to prevent build-up of mud and resulting corrosion and are easily accessible for easy cleaning by water hose. Panel surfaces are heavily insulated to absorb road noise.

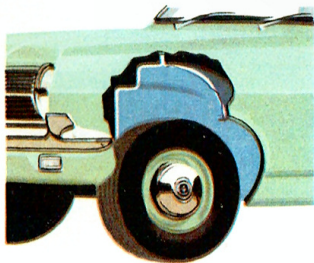

## **FRONT SUSPENSION CHANGES**

now mean that you can go 6000 miles or 6 months without requiring lubrication.

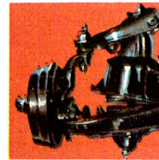

**SELF-ADJUSTING BRAKES** eliminate the need for periodic adjustment. An inbuilt device in each brake drum automatically takes up wear when brakes are applied while the vehicle is reversed.

## **NEW ALTERNATOR**

extends the life of your battery because it gives more even output, and charges even at engine idling speed. With no commutator to wear out, it lasts longer, saves on repairs.

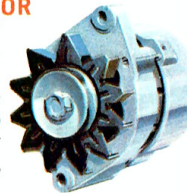

**EXCLUSIVE GMH 'MAGIC-MIRROR' ACRYLIC LACQUER** keeps your Holden's glossy showroom shine longer with a minimum of polishing. It resists cracking and chipping that are normal hazards of commercial operation to a remarkable degree.

## **NEW EXTENDED-LIFE MUFFLER**

assures you of more miles of quiet going. Intake tube and baffle plates are aluminised for increased resistance to corrosion, especially under severe conditions.

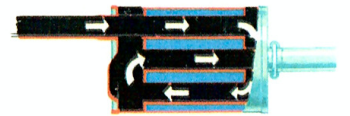

## **GMH GUARDIAN MAINTENANCE PROTECTION PLAN**

saves you money by keeping your Holden in top condition. A special booklet provides you with tear-out coupons for service up to 50,000 miles. Warranty protects you against defective workmanship or materials for 12 months or 12,000 miles.



**LOW-COST PARTS**, guaranteed by GMH, cost less and are more readily available. They're made to rigid GMH specifications, and give you longer service — and save you money. Parts and service for Holden are available through more than 600 Authorised Holden Dealers.



## AUSTRALIA'S OWN UTILITY AND PANEL VAN | SPECIFICATIONS

**MECHANICAL — 149 Engine:** Six cylinders. Bore, 3.25 ins. Stroke, 3.00 ins. Capacity, 149 cu. ins. Max. brake horsepower, 100 at 4,400 rpm. Max. torque, 145 lbs./ft. at 2,000. Compression ratio, 8.8:1. Also available with compression ratio, 7.7:1. 95 horsepower at 4,400 rpm. Max. torque, 135 lbs./ft. at 2,000 rpm. SAE or RAC rating, 25.3 h.p.

**179 Engine:** Six cylinders. Bore, 3.563 ins. Stroke, 3.00 ins. Capacity, 179 cu. ins. Max. brake horsepower, 115 at 4,000 rpm. Max. torque, 175 lbs./ft. at 1,600 rpm. Compression ratio, 8.8:1. SAE or RAC rating, 30.5 h.p.

**X2 Engine:** Six cylinders. Bore, 3.563 ins. Stroke, 3.00 ins. Capacity, 179 cu. ins. Max. brake horsepower, 140 at 4,600 rpm. Max. torque, 178 lbs./ft. at 2,200 rpm. Compression ratio, 8.8:1. SAE or RAC rating, 30.5 h.p.

**Engine Features:** OHV in line engine. Oversquare design. Modified wedge design combustion chambers. Seven-bearing crankshaft. Hydraulic valve lifters. X2 has aluminium alloy main and connecting rod bearings, twin exhaust manifolds.

**Fuel System:** Bendix-Stromberg single-barrel down-draft-type carburettor. AC fluid-treated replaceable paper element air cleaner and silencer. Fuel tank capacity, 11.5 imp. gallons. X2 engine air cleaner is a single unit with twin adaptors and oil-wetted polyurethane element. X2 also has twin carburettors and a high-lift camshaft. **Lubrication:** Full pressure lubrication system. AC full-flow disposable-type oil filter with oil non-return check valve.

**Cooling:** Pressured cooling system with full-length water jacket around each cylinder. X2 engine also has water-cooled inlet manifold. Thermostat control. Centrifugal water pump.

**Electrical System:** 12-volt battery with 44 amp. hour capacity at 20-hour rating, 35 amps. alternator (generator). Integral centrifugal and vacuum automatic advance control.

**Manual Transmission:** Three forward speeds and reverse. Synchromesh on second and top. Gears carburised and shot-peened.

**Automatic Transmission:** Powerglide. Hydraulic torque converter with planetary gear system.

**Brakes:** Four-wheel hydraulic, duo servo, reverse self-adjusting. Total effective lining area of 140.76 sq. ins. Power-assisted front wheel disc brakes are available as an extra cost option on both models.

**Suspension:** Front: Independent, with front wheel coil springing with short and long arms. Stabiliser bar. Rear: Semi-elliptic rear springs, six leaves. Direct-acting shock absorbers front and rear.

**Steering:** Recirculating ball. Ratio, 16.8:1. 36½ ft. turning circle.

**Wheels and Tyres:** Demountable disc wheels, 13 x 4.50 J. Tubeless 6.40 x 13 x 6-ply tyres. Safety rims.

**Lighting:** Sealed beam headlamps. Foot-operating dimmer switch. Dual stop and tail lights. Rear licence plate lamp. Self-cancelling flashing

turn indicator lights — front and rear. Parking lights combined with front turn indicator lights. Passenger compartment lamp. Indirect instrument panel lighting. Illuminated selector quadrant (automatic models). Back-up lamps standard on automatic models.

**BODY — Body Structure:** All-steel Aerobilt construction. Dimensions: Wheelbase, 106.0 ins. Track — front, 53.9 ins.; rear, 54.5 ins. Overall length, utility and panel van, 179.8 ins. Overall width, 70.0 ins. Ground clearance, 7.3 ins. Overall height at kerb weight, utility, 59.73 ins. and panel van, 67.23 ins.

**Instrument Panel:** Safety-padded. Speedometer. Petrol gauge. Water temperature light, oil pressure and generator charging telltale lamps. Turn indicator telltale lamps. High beam indicator lamp. Five-position ignition/starter switch. Main light switch. Windshield wiper switch. Choke control knob. Ash tray. Glove box with locking lid. Plenum chamber ventilation control lever. Engine hood lock control knob. Models with X2 Engine: Oil pressure gauge, ammeter and water temperature gauge.

**EQUIPMENT — Both Models:** Electric two-speed dual windshield wipers. "Modified Zone" windshield. Provision for seat belt installation. Two-spoke dish-type steering wheel with horn actuating rocking bar recessed in spokes. Fully adjustable front seat. Seat fitted with "Z" type spring. Elascofab upholstery. No-draught ventilators with locks. Sun visor. Front door lock operating key also operates ignition/starter switch, lock on glove box lid, load compartment, tailgate on the panel van.

Hold-open door checks. Interior rear vision mirror. (Exterior mirror fitted where required by State Law.) Inner front fenders. Door sill, scuff plates. Rubber mat floor covering. Load compartment floor boards of laminated wood with painted skid strips. Counter-balanced engine hood.

**Estimated Kerb Weights:** Utility, 2,603 lbs. Panel Van, 2,684 lbs.

Add 63 lbs. for Powerglide Transmission.

**Payload:** Utility and panel van, 10 cwt.

Specifications and equipment subject to change without notice.

### GMH FACTORY WARRANTY

When you purchase your Holden Utility or Holden Panel Van, the GMH Factory Warranty protects you against defective workmanship or materials for 12,000 miles or 12 months, whichever comes first. Expert Holden Service (including free 1,000 and 2,000 mile services) and a supply of low-cost factory-guaranteed parts are available from over 600 Authorised Holden Dealers. General Motors Acceptance Corporation confidential finance arrangements are available for your convenience.

GENERAL MOTORS-HOLDEN'S PTY. LTD. Brisbane, Sydney, Melbourne, Adelaide, Perth

## Designed for Australia, proved by Australians!

Holden is the only utility and panel van specifically designed for Australia. And at the GMH Proving Ground the new Holden Utility and Panel Van have been tested under every kind of Australian operating condition. Holden's suspension, its tough frame and transmission, its powerful brakes and precise steering have all proved they have the ruggedness and quality to stand up and serve you well in every situation. Holden's engines have been tested and re-tested. Everything about the new Holden Utility and Panel Van, right down to the 7.3 in. ground clearance so necessary in rugged going, is proved right for Australia. Proved to give you more profitable operation. Proved to give unmatched value for your money!



General Motors-Holden's  
Issued 8/65  
Copyright