

easy purchase options

Finance

SmartChoices, provided by GMAC Financial Services, is an array of automotive finance products designed to help the dream of driving a new Holden become a reality. Just select the product, term and payment structure that best suits your lifestyle and your Holden Dealer can provide more information.

Insurance

Holden Insurance offers a range of competitively priced insurance products, providing tailor-made protection, at whatever level of cover you need. For more information, call the Holden Insurance hotline on 1300 784 026.

Holden Leasing

Businesses of all sizes are now accessing vehicle leasing options with Holden Leasing. We operate nationally through the Holden Dealer Network and our dedicated service and support team. Our people are responsive professionals who understand your business and what it means to deliver total fleet management solutions. To find out how Holden Leasing can help you, call us on (03) 9693 0400.

Holden MasterCard

Holden MasterCard can assist you to get into a new Holden sooner. 10% of your credit card purchases go towards a Rebate of up to \$3,000 on your new Holden¹ (depending on model). That's up to \$1 saving on your new Holden for every \$10 spent. There are a range of extra features including up to 45 days interest free² on credit card purchases and a competitive interest rate. Apply³ online at www.holden.com.au/mastercard, or call MasterCard's 24hr helpline on 131 200.

ownership benefits

Holden Service

With over 300 Holden Dealers, Holden can supply an enviable level of customer care. Our Service Network is one of the largest in the country. Only Holden Dealership technicians have access to regular Holden factory training and equipment.

Holden New Vehicle Warranty

Every new Holden comes with a New Vehicle Warranty, covering your Holden for 3 years⁴ or 100,000 kilometres, whichever comes first. This factory backed warranty covers items including the engine, transmission, interior and exterior components. Refer to your Owner's handbook or see your Holden Dealer for full terms, conditions and exclusions.

Holden PLUS Extended Factory Warranty

Holden also offers Holden PLUS Extended Factory Warranty. Holden PLUS is a complete extension of your New Vehicle Warranty, giving you peace of mind because your car is factory backed for up to 3 additional years. The very same items covered under the New Vehicle Warranty will continue to be covered under Holden PLUS, without exclusion. Simply select a 1, 2 or 3 year Holden PLUS Extended Factory Warranty at the time you purchase your new Holden. See your Holden Dealer or call 1300 308 062 for full terms and conditions.

24 Hour Roadside Assistance

Provided for the first one year of your new Holden's life⁵. Holden's Roadside Assistance is one of the most comprehensive roadside assistance packages with over 3000 Roadside Assistance patrols nationwide⁶. There to help with even the smallest service, the toll free Roadside Assistance hotline is always open, 1800 817 100.

For more information contact

Holden Customer Assistance on 1800 033 349 Monday to Friday
8am to 7pm or Saturday 9am to 1pm EST or visit
www.holden.com.au

¹ A total of \$3000 in the form of Holden Card 'Core Rebate' (plus additional 'Bonus Rebate' accumulated via the Partner Program) accrued over a maximum of five years may be applied per eligible vehicle purchased. Vehicle sales for which a fleet allowance is paid are not eligible for Holden MasterCard Rebate. Earning and redemption of Rebate towards a new Holden is subject to the Holden Card Rebate Program Rules. ² The interest-free period applies where the card account is fully paid by the due date each month. ³ Applications are subject to Westpac's normal lending criteria. ⁴ From date of first registration. ⁵ In remote or sparsely populated areas you may experience delay in obtaining Roadside Assistance. Refer to the Roadside Assistance brochure in your glovebox for full terms and conditions of this service.

A word about this catalogue. We have tried to make this catalogue as comprehensive and factual as possible. However, since the time of printing some of the information you'll find here may have been updated. Also, some of the equipment shown or described through this catalogue may have been changed and / or is available at extra cost. Further, GM Holden Ltd, reserves the right to make changes at any time without notice, in prices, colours, materials, equipment and models. Your Holden Dealer has details, and before ordering, you should ask them to bring you up to date. No Holden Dealer or other person is authorised or permitted to give or make any statement, assertion or undertaking in relation to the quality, performance characteristics, descriptions or fitness for any purpose of any Holden product which is at variance with any written statement, assertion or undertaking on any of these subjects given or made by GM Holden Ltd ABN 84 006 893 232 in its published sales literature, and GM Holden Ltd does not accept any liability for any such unauthorised action. GM Holden Ltd has authorised dealers in many parts of Australia for the sale of service parts and the provision of service to owners of Holden's products. Every endeavour is made to ensure that such dealers carry adequate stocks of service parts, but GM Holden Ltd doesn't make any promise other than that contained in the New Vehicle Warranty given by GM Holden Ltd that such parts or service facilities will be available at any specific location or at any particular time. Express warranties offered for Holden products are subject to the conditions set out in all vehicle handbooks. Details also available from GM Holden Ltd on request. Copyright GM Holden Ltd, February 2007. emerystudio CAPT1006 AD12200



Go to new heights

Call it a paradox. Call it a misnomer. But Sports Utility Vehicles are seldom sporty, and fewer still offer real utility.

Some are all show and no go. Others are great for short trips but grate over long distances. Some look big and unwieldy, or at least feel that way to drive. And most are designed to go no further off road than a car park.

Now. Finally. There's one SUV that lives up to the mantle. Seating for five or seven. Up to 1,565 litres of storage. High output V6 or 4 cylinder turbo diesel engine. 5-speed automatic transmission with Active Select. Active All Wheel Drive. Advanced safety systems, including Active Rollover Protection and Electronic Stability Control.® And most important of all, Holden's legendary ride and handling – on road and off.

All in a vehicle no larger than a mid-sized sedan.

The new Holden Captiva. Four brilliant models: SX, CX, LX and Captiva MaXX. One tough choice.

Captiva heralds a new generation in SUV thinking, styling, safety and performance. No shortcuts. No shortcomings. No compromise. Now, wherever you go, you really can enjoy the journey as much as your destination.

The Holden Captiva. It takes sports utility motoring to new heights.

Captiva LX
Mercury Silver
7 seats
18 inch alloy wheels



A design of the times

The new Captiva's arching, beautifully streamlined contours are impossible to miss and even harder to ignore.

Head on, Captiva's high ground clearance gives it an imposing and purposeful presence. Its immense capabilities and capacity to please, expressed perfectly by the 'ready to go' look of its dynamically sculpted front end.

The poised, supremely confident stance. The seamless aerodynamic sweep of the roof and body lines. The tapered rear. The side fender vents, twin exhaust tips and horizontal bar emblazoned across the grille. Captiva is every inch a Holden. And proudly so.

Safety and ergonomics further shape the vehicle's design. Silver decorative skid plates and protective body and wheel arch mouldings combine form with function to safeguard the vehicle off road. Distinctive vertical tail lamps, centre high-mount stop lamp and large reversing indicators heighten on-road safety. Its wide doors and remote controlled opening tailgate window on Captiva SX, CX and LX simplify vehicle entry, exit and cargo access.

Bold. Sleek. Superbly proportioned. Strikingly individual. A design of the times, new Captiva is the shape of things to come in sports utility motoring.

Captiva LX
Granada Black
7 seats
18 inch alloy wheels



A place for everyone and everything

People mover. Transport van. Urban warrior. Long-distance tourer. Off-road trekker. New Captiva is all this and more.

Need to seat seven – or at least be able to, just in case? The three-row seating in Captiva CX and LX lets you do just that, without compromising anyone's comfort.

No back seat passengers? Tilt the headrests down for an uninterrupted rear view. Or use the 50:50 split feature in the third row and second row 60:40 split, to create whatever size and shape of cargo space you require.

A flick of the wrist – that's all it takes – and seats disappear entirely, folding virtually flush with the floor. Even the front passenger seat folds down, allowing you to carry objects up to 2.7 metres in length.

Flexibility is also the go in the five-seater Captiva SX and range-topping Captiva MaXX, which offer 930 and 865 litres of cargo storage, respectively, with second row seating folded away. Both models also offer substantial below cargo floor storage, with the SX's 140 litre space even including separate wet and dry compartments.

In fact, depending on the model you go with, you'll find as many as 25 individual storage compartments integrated into the cabin. From the handy coin and parking ticket holders for the driver, to seat back pockets, console bins, cup holders and door wells large enough to hold one litre water bottles. Not to mention a cooled glovebox and roof rails, both standard on the Captiva MaXX and LX.

With a place for everyone and everything in its place, the adaptable, practical new Captiva makes every journey that much easier.

Captiva LX
Mercury Silver
7 seats
18 inch alloy wheels





A dynamic yet refined, sedan-like ride

Bitumen or dirt track. Fair weather or foul. New Captiva delivers precise, composed and consistent handling across the best and worst of Australia's myriad driving conditions.

The speed sensitive power steering ensures enhanced road feel and linear response at all speeds, allowing you to drive Captiva intuitively in all situations. Tight parking spots. Twisting country roads. Fast moving freeways. It's all the same.

The vehicle's suspension was calibrated on Australian roads, for Australian drivers. MacPherson struts up front. Independent four-link axle at the rear. Taking the rough with the smooth, the finely tuned shock absorbers, spring rates and stabiliser bars deliver a dynamic yet refined sedan-like ride.

Comfort, handling and safety on Captiva CX and LX are further enhanced by hydraulic ride control, which automatically adjusts the vehicle's suspension dampers to maintain a consistent 200mm ride height regardless of how heavily the vehicle is loaded.

Holden's Active All Wheel Drive is standard across all four models. Continually monitoring the vehicle's progress, it determines whether front wheel or four wheel drive is required for optimum traction, and instantly re-directs power accordingly, up to a 50:50 split. This not only improves on-road safety, it improves fuel economy, because engine power is not wasted driving the rear wheels unnecessarily.

Captiva's Electronic Stability Program further heightens driving safety. Integrated with the vehicle's Active All Wheel Drive and ABS systems, it applies braking and/or adjusts power to each wheel individually, keeping Captiva on the course you intend and away from potential danger.

Sounds impressive? Wait 'til you get behind the wheel. Then factor in the price. New Captiva is the complete package. You'd go a long way before finding a better value SUV – if you could find one at all.

Captiva LX
Granada Black
7 seats
18-inch alloy wheels



Taking it to the MaXX

Sleeker outside. Sexier inside. Sportier on the road. Captiva MaXX is more than the flagship of the new Captiva range, it's a completely different driving experience.

Look closely enough at the vehicle's taut, muscular exterior and you'll see every panel, every lamp, every detail is distinctly different to the three other models. It's more European. More edgy. More exciting.

Inside, the dynamic design theme continues. Contemporary colours and textures blend with traditional sports car touches, like the deep instrument binnacle, three spoke leather wrap steering wheel and deep cushion leather trim faced seats to create a stunning, driver-oriented cockpit-style interior.

With its 18 inch alloy wheels in motion, Captiva MaXX handles with irrepressible, sports car-like enthusiasm. The ride is firm. The steering, fast and precise. The road connection, unmistakably Holden-like in its directness.

A luxury sports utility vehicle with a sports car profile and personality, the wonderfully unique Captiva MaXX promises exhilarating motoring from go to whoa.

Captiva MaXX
Silverstone Grey
5 seats
18 inch alloy wheels

A superbly realised cabin

It's an easy climb into the driver's seat, but the views from Captiva are breathtaking.

Ahead, there's more road than you could ever hope to see from a sedan. In front, a dash of style and substantial thoughtfulness. And all around you, the wide open spaces and craftsman-like attention to detail of the superbly realised cabin.

Fusing classic and modern design cues, Captiva displays primary driver information via a cluster of easy-to-read analogue instruments, and faultless logic in the dramatic cascade of its centre console controls – close for easy reach, large for easy grip and clearly defined for ease of operation, they make it easy to adjust your driving environment without losing focus on the road.

Driving safety is further enhanced by steering mounted paddles, which allow you to operate Captiva's MP3 compatible CD audio system and cruise control without taking your hands from the wheel. Controls for lamps, indicators, door and tailgate locks, wipers, side mirrors and windows are also placed intuitively and within easy reach.

Numerous other features are also close at hand, including vanity mirrors, map lamps, sunglasses holder and adjustable headrests for the driver and front passenger; three 12-volt power outlets; load tie-down hooks in the cargo area; and a plethora of on-board storage compartments. All standard across all models.

Setting new standards in value for money, the five seat Captiva SX also includes air conditioning, while the seven seat CX, includes air conditioning and a six speaker, six CD audio system.

Anything but standard, the luxurious Captiva LX and sports luxury Captiva MaXX also include a six CD audio system, plus twin-needle stitched leather faced seating, leather wrap steering wheel, eight way power driver's seat with adjustable lumbar support, electronic climate control and multi-function driver information display – the whole box and dice.

Designed to please. Built to last. Inside and out. On road and off. Holden Captiva takes sports utility motoring to new heights in every way.

Captiva LX



Captiva MaXX



Safety

From simple yet critical features – like large side mirrors, lap/sash seatbelts for every seat position, anchorages for three child restraints and childproof rear door locks – to advanced active and passive safety technology, Captiva goes to new heights to help prevent collisions and protect you from injury in the event of collision.

Active safety

To help make your every journey as safe as it is enjoyable, Captiva monitors on-road dynamics every moment that you're driving. Everything from the vehicle's speed, lateral acceleration and rotation, to the steering wheel angle and brake force you apply.

When normal tolerances are exceeded, one or more active safety systems initiate non-intrusive counter measures to help you retain maximum control of the vehicle.

Co-ordination of active safety features Fully co-ordinated and tightly integrated, new Captiva's active safety systems provide you with 360° support:

- Active Rollover Protection (ARP) and Electronic Stability Program (ESP®) assist you during turning, cornering and lane changes.
- The Traction Control System (TCS) works with Captiva's Active All Wheel Drive to reduce wheel slip when accelerating.
- The Anti-lock Braking System (ABS), Brake Assist (BA) and Electronic Brakeforce Distribution (EBD) help you stop as quickly as possible.

ARP Active Rollover Protection Should it detect excessive body roll during cornering or a lane change, ARP applies braking to each wheel as required, with extra brake force directed to those wheels with the most grip. The vehicle's speed reduces, and with it, the amount of roll.

ESP® Electronic Stability Program ESP® constantly compares the vehicle's movements with the steering wheel angle to determine if the vehicle is moving in the direction you intend. If skidding appears imminent, ESP® applies brake pressure to individual wheels as appropriate and, if necessary, trims engine power. This dramatically increases turning and cornering safety, especially in 'evasive action' situations.

TCS Traction Control System TCS is designed to minimise slippage during acceleration. If either front wheel has insufficient grip, TCS works in conjunction with Captiva's Active All Wheel Drive system to adjust drive force, front/rear torque distribution and brake force accordingly. It reduces wheel spin when accelerating on wet and icy roads, and also in 'split' conditions, such as when a vehicle has two wheels on bitumen and two on a gravel verge.

ABS Anti-lock Braking System If wheel 'lock up' is detected under forceful braking, ABS momentarily reduces brake pressure at the affected wheel(s). This improves braking efficiency – reducing stopping distances on most surfaces – and helps the vehicle to remain steerable and directionally stable.

BA Brake Assist In emergency braking situations, few drivers actually press the brake pedal firmly enough to achieve adequate braking performance. BA is designed to sense how fast you hit the brake pedal in an emergency, and increases braking pressure to achieve the best possible braking performance.

EBD Electronic Brakeforce Distribution When a vehicle brakes, weight transfers to the front wheels. By regulating the brakeforce applied to each wheel, EBD helps ensure the best possible balance between front and rear brakes, which helps minimise stopping distances.

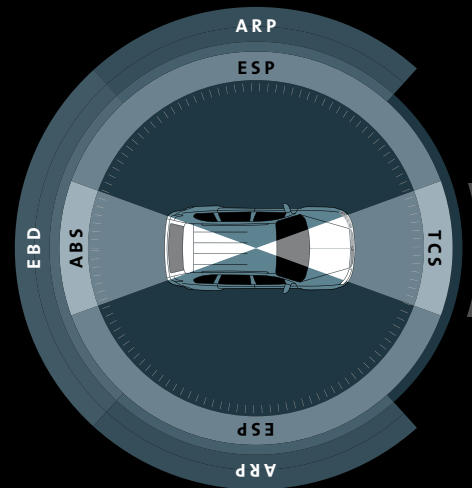

So what if... You have to avoid an unexpected obstacle in the road, end up with two wheels on the gravel verge then need to brake suddenly.

Detecting excessive body roll, ARP brakes all four wheels, with extra force applied to the front outside wheel; the rear left wheel is then braked momentarily by the ESP® to counter understeer.

TCS reduces torque to the left front wheel to reduce slip, while AWD directs a proportion of torque to the rear wheels to increase grip.

ESP® brakes the front right wheel momentarily and reduces engine power to all four wheels to correct oversteer, and AWD directs all engine torque to the front wheels.

Sensing an emergency stop, BA initiates maximum brakeforce, ABS improves brake efficiency and EBD achieves the best possible front/rear brake balance.

Passive safety

In an accident, it's the impact energy of the collision versus your vehicle's safety systems. That's why Captiva puts all these features on your side:

- Dual front airbags
- Full length curtain airbags on Captiva CX, LX and Captiva MaXX*
- Front and rear crumple zones
- Multiple load paths to channel impact energy away from the vehicle's high strength steel safety cell
- A petrol tank mounted forward of the rear axle
- Reinforced front doors, B pillars and rear section

Co-ordination of passive safety features Captiva uses forward and side sensors to detect the direction and severity of a collision, then co-ordinates and deploys, if necessary, the appropriate safety measures – all in just a few thousandths of a second. Which is roughly the same time it takes to snap your fingers.

- 1 Standard driver and front passenger airbags
- 2 Curtain airbags
- 3 Front seatbelt sash height adjustment and front seatbelt force limiter
- 4 Pyrotechnic front seatbelt pre-tensioners
- 5 Childproof rear door locks
- 6 Three rear seat child restraint anchorages
- 7 Rear Park Assist (accessory)

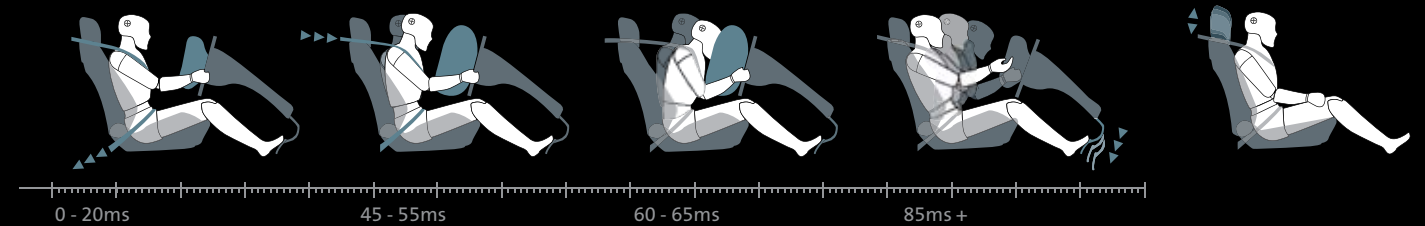
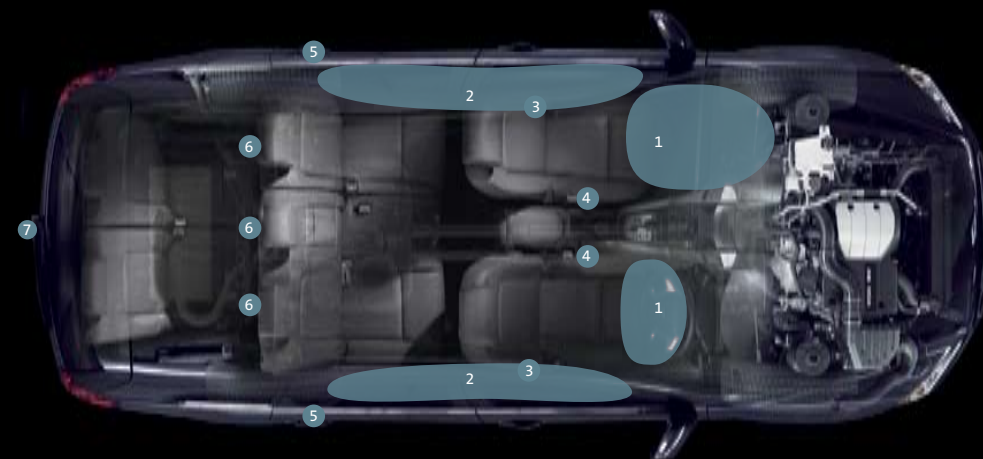

Pyrotechnic seatbelt pretensioners When an impact of sufficient severity is detected, small explosive charges force the front seatbelt buckles towards the cabin floor. This tightens the seatbelts and holds both driver and front passenger firmly against their seats.

Front airbags For maximum protection in certain frontal collisions, Captiva will deploy front airbags for the driver and passenger.

Curtain airbags Full length curtain airbags* provide head and upper body protection for front seat occupants and left and right second row passengers in certain side-on collisions.

Load limiters Following airbag deployment, load limiters unspool the front seatbelts incrementally to minimise the risk of seatbelt related injury.

Pedal safety In a severe frontal impact, the brake pedal detaches to help prevent lower limb injury to the driver. Further protection to the driver is provided by an energy-absorbing knee guard.

Height adjustable rear seat head restraints For greater protection against whiplash injuries caused by rear collisions, second row passengers are able to adjust the position of their head restraints.

Height adjustable lap/sash front seatbelts To maximise seatbelt effectiveness, the driver and front passenger can each lower or raise their seatbelt sash to ensure it sits correctly in the point between their neck and the point of their shoulder.

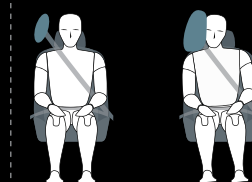

*Curtain airbags are standard on Captiva CX, LX and Captiva MaXX, and optional on Captiva SX.

ESP® is a registered trademark of Daimler Chrysler AG

Diagrams not to scale

Power

Two exceptional new engines. One endlessly exhilarating driving experience. Whether you have the 3.2 litre Alloytec V6 petrol engine under the bonnet of your Captiva, or the 2.0 litre Common Rail Turbo Diesel, you can look forward to motoring that's every bit as free-spirited as you are.

Alloytec V6

Holden's legendary Alloytec range includes some of the most sophisticated and advanced production engines ever manufactured in Australia. And the all new, high output 3.2 litre Alloytec V6 – purpose-designed for Captiva – is no exception.

Maximum power: 167/169kW[^]
Maximum torque: 297Nm

Maximum driving pleasure guaranteed thanks to an array of performance-enhancing technology:

- Aluminium construction means a better power-to-weight ratio, and also allows the engine to withstand higher combustion temperatures for optimal efficiency and minimal emissions.
- Dual continuous variable cam phaser and a variable intake manifold improve performance and torque, while at the same time reducing fuel consumption.
- Electronic Throttle Control, for improved launch and sportier acceleration with optimal fuel efficiency.
- Adaptive spark control, enabling the engine to run with maximum efficiency on either unleaded or premium unleaded fuel (91 or 95 RON).
- A transverse, four point neutral torque axis mounting system to minimise engine noise and vibration, especially when idling.
- Euro IV compatibility means exhaust emissions are below that currently required by Australian legislation.

On road or off, with its extra wide torque curve and effortless, sports-like response across a broad range of revs, the Alloytec V6 will never miss an opportunity to delight the driver in you.

[^] Maximum power output is 169kW for Captiva SX, CX and LX models; and 167kW for Captiva MaXX

Power and Torque figures as per ECE regulations using 95 RON fuel

5-speed automatic transmission with Active Shift Control and Active Select (standard on all petrol models)

Complete with Active Shift Control, which monitors the way you drive and adapts shift ranges accordingly, this 5-speed automatic transmission delivers fast, virtually seamless gear changes, and is the perfect mate to Captiva's 3.2 litre Alloytec V6.

For a more hands on driving experience, you also have the option to engage Active Select, which allows you to manually power up and down Captiva's exquisitely spaced gear ratios.

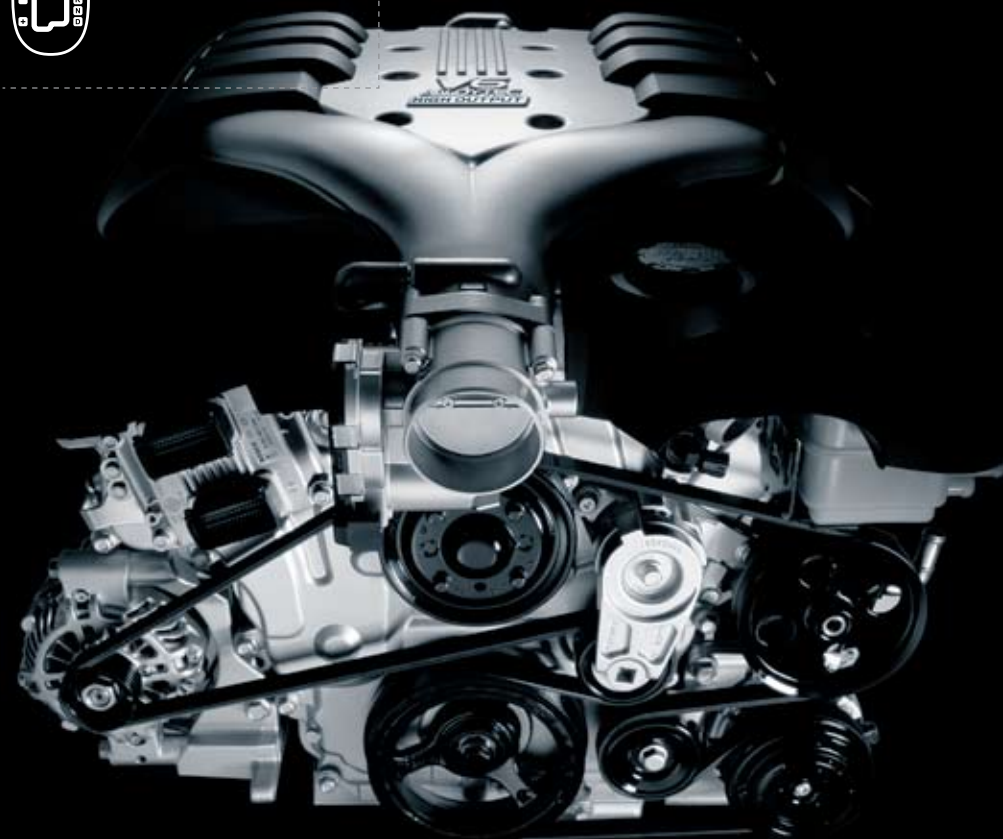

Common Rail Turbo Diesel

New era diesel technology for a new generation of savvy SUV drivers, Captiva's Common Rail Turbo Diesel engine offers all the benefits of diesel power with none of the traditional downsides.

Quiet. Smooth. Responsive. Reliable. Incredibly fuel efficient. Euro IV emission standard compliant. The 2.0 litre four cylinder delivers potent turbocharged performance with enormous torque on tap from low revs through to high. Hill ascents, overtaking and towing couldn't be easier or more enjoyable.

It's the state-of-the-art common rail fuel delivery that makes the difference. By keeping fuel under constant pressure within the engine system, it enables electronic fuel injectors to release precisely the right amount of fuel into the engine cylinders at precisely the right time.

This results in vastly more efficient fuel combustion, producing an enormous boost in engine torque and power across a wide rev range, plus substantially reduced engine emissions.

All of which helps explain why common rail diesel is the fastest growing engine technology in the world. Just as numbers like these explain why Captiva's new turbo diesel is likely to attract the same interest in Australia:

- Maximum power of 110Kw at 4000rpm
- Maximum torque of 320Nm at 2000 rpm
- 24% more fuel efficient than Captiva's Alloytec V6^{*}
- 25% less CO₂ emissions than Captiva's Alloytec V6[^]

^{*} Captiva Diesel 2.0 litre auto compared with Captiva Petrol 3.2 litre auto

[^] Captiva Diesel 2.0 litre SX manual compared with Captiva Petrol 3.2 litre auto

Fuel consumption figures based on ADR81/01 tests

Power and Torque figures as per ECE regulations

5-speed automatic transmission with Active Shift Control and Active Select (optional on SX, standard on CX and LX diesel models)

Captiva's 5-speed automatic transmission is equally at home as the turbo diesel's running mate, and its gear changes just as precise and silky smooth.

5-speed manual transmission (SX only)

If your choice of Captiva is an SX, and your preferred engine is the Common Rail Turbo Diesel, you have the option of completing your Captiva powertrain with a short throw, sweet shifting 5-speed manual transmission.

It's the ultimate way to experience the turbo diesel's seemingly endless torque.



Engine hardware varies

All Wheel Drive

AWD Active All Wheel Drive

Captiva's Active All Wheel Drive System automatically divides engine torque instantly and seamlessly between the front and rear wheels, depending upon driving conditions.

Normally, Captiva is driven from the front wheels only, resulting in greatly improved fuel economy compared with traditional four wheel drive systems. However, the moment the vehicle's sensors detect a situation where four wheel drive would be preferable, up to 50% of engine torque is directed to the rear wheels.

As a result, the vehicle's full power is transferred to the road, even in tight corners, during hill starts or on slippery surfaces, such as wet or icy roads.

Captiva's Active All Wheel Drive is also fully integrated with the vehicle's Electronic Stability Program and Anti-lock Braking System and can be deployed automatically to counteract vehicle instability in a range of situations.

- 1 Engine
- 2 Transmission
- 3 Power Transfer Unit (PTU)
- 4 Cardan shaft
- 5 Front axle
- 6 Rear axle
- 7 Rear Drive Module (RDM)
- 8 Electromagnetic clutch
- 9 Data bus connection
- 10 Control unit

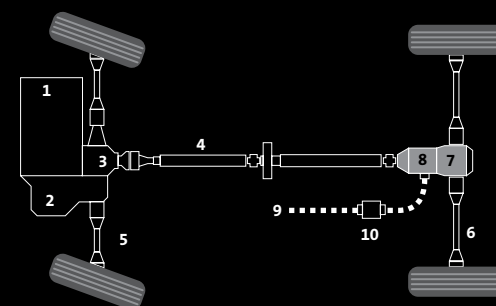

DCS Descent Control System

Activated with the touch of a button, Captiva's Descent Control System uses engine control and automatic braking to limit downhill speed.

A pre-requisite for any truly capable off-roader, it enables smooth, controlled hill descents and allows drivers to concentrate primarily on steering.

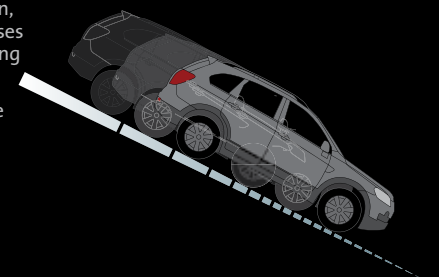



This is where the fun begins. Where sports utility motoring heads to bold new heights. Where you belong. Easy to get into, impossible to walk away from, Captiva SX combines head-turning good looks with a practical yet stylish five-seat interior, V6 or turbo diesel power and the very latest in engine, transmission and safety technology. Capable off road. Sedan-like on road. Never has there been a better value for money SUV.

Standard features include:

- 3.2 litre high performance V6 Alloytec engine, or
- 2.0 litre Common Rail Turbo Diesel engine
- 5-speed automatic transmission with Active Select and adaptive shift control, or
- 5-speed manual transmission (Diesel only)
- Seating for five, with fold-flat second row seats
- Driver and front passenger airbags (with optional curtain airbags)
- Air conditioning with particle filter
- 4-speaker stereo with in-dash CD, MP3 compatibility and radio
- 17 inch, five-spoke alloy wheels
- Active All Wheel Drive
- Cruise control
- Electronic Stability Program (ESP®) incorporating:
 - Anti-lock Braking System (ABS)
 - Electronic Brakeforce Distribution (EBD)
 - Brake Assist (BA)
 - Traction Control System (TCS)
 - Active Rollover Protection (ARP)
- Descent Control System (DCS)
- Large power side mirrors
- Power windows front and rear
- Below cargo floor storage with separate wet/dry compartments
- Remote controlled opening tailgate window
- Twin exhaust outlets
- Three rear-seat child restraint anchor points
- Keyless entry



Hard wearing cloth trim seats combine comfort and practicality with contemporary style.



The SX lets you team Captiva's Common Rail Turbo Diesel with a sweet shifting 5-speed manual transmission for maximum driving pleasure.



Rain or shine, the under floor wet and dry storage compartments help you keep Captiva SX clean and tidy.



Captiva's remote key lets you lock and unlock all four doors, fuel filler door and/or the tailgate window.



For added convenience, you can open the tailgate window on Captiva SX, CX and LX independently of the tailgate.





Places to see? People to go with? Captiva CX gives you the capacity to seat seven in real comfort and the power to take them off-road. All in a vehicle no larger than the average sedan, but infinitely more rewarding to drive. In Captiva CX, everyone can come along for the ride – and enjoy it.



Steering mounted paddles let you operate Captiva's intuitive cruise control without taking your hands from the wheel.



With a flick of the wrist, Captiva's Active Select lets you switch from automatic to manual gear shifting.



The split folding second and third row seats on Captiva CX give you the flexibility to carry seven in comfort, or a small mountain of cargo.



With three 12-volt outlets located throughout the cabin, Captiva has the power to operate all your personal and vehicle accessories.



Smart storage solutions abound within the Captiva's clever cabin – some are large, others are compact, all are close at hand and easily accessed.

Standard features include:

- 3.2 litre high performance V6 Alloytec engine, or
- 2.0 litre Common Rail Turbo Diesel engine
- 5-speed automatic transmission with Active Select and adaptive shift control
- Seating for seven, with fold-flat second and third row seats
- Driver and front passenger airbags, plus curtain airbags
- Air conditioning with particle filter
- 6-speaker stereo with six-disc in-dash CD, MP3 compatibility and radio
- Centre console with dual lid and sliding armrest
- 17 inch, six-spoke alloy wheels
- Level Ride Suspension
- Active All Wheel Drive
- Cruise control
- Electronic Stability Program (ESP®) incorporating:
 - Anti-lock Braking System (ABS)
 - Electronic Brakeforce Distribution (EBD)
 - Brake Assist (BA)
 - Traction Control System (TCS)
 - Active Rollover Protection (ARP)
- Descent Control System (DCS)
- Large power mirrors
- Power windows front and rear
- Remote controlled opening tailgate window
- Twin exhaust outlets
- Three rear-seat child restraint anchor points
- Keyless entry





Family limousine. Mobile five-star resort. Journey and destination rolled into one. The new Captiva LX is not just a step up, it's a whole new class of SUV. Leather trim faced seating for seven. Space for up to 1,565 litres of cargo. Every time you drive, your every need anticipated and catered for in luxury and exhilarating style. The LX is more than an SUV, it's a way of life.

Standard features include:

- 3.2 litre high performance V6 Alloytec engine, or
- 2.0 litre Common Rail Turbo Diesel engine
- 5-speed automatic transmission with Active Select and adaptive shift control
- Double-stitched, leather trim faced seating for seven, with fold-flat second and third row seats
- Driver and front passenger airbags, plus curtain airbags
- Electronic climate control with air conditioning and air quality sensor
- 8-speaker stereo with six-disc in-dash CD, MP3 compatibility and radio
- Multi-function driver information display, complete with electronic compass
- Centre console with dual lid and sliding armrest
- 18 inch, seven spoke alloy wheels
- Level Ride Suspension
- 8-way adjustable power driver's seat
- Leather wrap steering wheel
- Front and rear fog lamps
- Roof rails
- Active All Wheel Drive
- Cruise control
- Electronic Stability Program (ESP®) incorporating:
 - Anti-lock Braking System (ABS)
 - Electronic Brakeforce Distribution (EBD)
 - Brake Assist (BA)
 - Traction Control System (TCS)
 - Active Rollover Protection (ARP)
- Descent Control System (DCS)
- Large, heated power side mirrors with integrated turning indicators
- Power windows front and rear
- Remote controlled opening tailgate window
- Chrome-plated twin oval exhaust outlets
- Three rear-seat child restraint anchor points
- Keyless entry

Twin chrome oval exhaust tips and the stylish rear decorative skid plate ensure Captiva is as distinctive and recognisable from behind as it is from the front and side.

Integrated into the centre second row seat is a convenient fold down armrest, which also doubles as a discreet storage box.

While Captiva's climate control system is keeping you and your passengers cool on hot days, its cooled glovebox will be doing the same for your drinks and travel snacks.

The eight speaker, six disc audio system in Captiva LX plays CDs, MP3 tracks and also includes an auxiliary input jack for MP3 player connectivity.

In addition to displaying electronic climate control settings, the driver information display on Captiva LX includes a handy electronic compass.

The eight way adjustable leather trim faced power driver's seat makes it easy for you to find your perfect driving position.



Same DNA. Different SUV. With its elegant, sports-inspired exterior, sports-tuned ride and handling and luxurious, cockpit-like interior, the new Captiva MaXX sets a stunning new benchmark in high performance sports utility motoring. At home in the fast lane. At ease on and off the road less travelled. With room for five adults and a capacity to delight beyond all expectation, this is truly a Holden to behold.

Standard features include:

- 3.2 litre high performance V6 Alloytec engine
- 5-speed automatic transmission with Active Select and adaptive shift control
- Double-stitched, leather trim faced seating for five adults, with fold-flat second row seat
- Driver and front passenger airbags, plus curtain airbags
- Electronic climate control with air quality sensor
- 7-speaker stereo with six-disc in-dash CD, MP3 compatibility and radio
- Multi-function driver information display
- Centre console with dual lid and sliding armrest
- Storage tray under the front passenger seat
- 18 inch, five spoke alloy wheels
- 8-way adjustable power driver's seat
- Leather wrap steering wheel
- Front fog lamps
- Roof rails
- Active All Wheel Drive
- Cruise control
- Electronic Stability Program (ESP®) incorporating:
 - Anti-lock Braking System (ABS)
 - Electronic Brakeforce Distribution (EBD)
 - Brake Assist (BA)
 - Traction Control System (TCS)
 - Active Rollover Protection (ARP)
- Descent Control System (DCS)
- Large power side mirrors
- Power windows front and rear
- Below cargo floor storage
- Twin exhaust outlets
- Three rear-seat child restraint anchor points
- Keyless entry



The leather wrap steering wheel ensures maximum grip, while the steering mounted controls enable you to operate the sound system without moving your hands from the wheel.



The eight way power driver's seat in Captiva MaXX enables fingertip control of slide and recline adjustment, plus individual height control of the front and rear cushions.



Captiva's intuitive climate control operation allows you to set the cabin environment instantly and precisely to your exact requirements.



The concealed tray under the front passenger seat is just one of two dozen storage spaces and compartments provided within the meticulously designed cabin.



	167kW/169kW, 3.2 litre high performance Alloytec V6 engine	110kW, 2.0 litre variable geometry common rail turbo diesel engine	
Engine	3.2L 60-degree Double Overhead Cam V6 with 4 valves per cylinder. Sequential fuel injection. High energy, distributorless ignition. Twin knock control sensors with individual cylinder adaptive control. On-board diagnostics. Electric cooling fan. Stainless steel exhaust. Low restriction air intake with acoustic dampening chambers. Continuously variable camshaft phasing for inlet and exhaust cams. Variable intake manifold. Coil-on-plug	In-line SOHC 16 valve 4 cylinder. Cast iron aluminium. High pressure. Direct injection. Variable Geometry Turbocharger. Charge Air Cooler. Diesel particulate filter	
Capacity (cc)	3195	1991	
Compression ratio (:1)	10.3	17.5	
Maximum power (ECE, kW)#	SX, CX, LX: 169 @ 6600rpm	MaXX: 167 @ 6600rpm	110 @ 4000rpm
Maximum torque (ECE, Nm)#	SX, CX, LX: 297 @ 3200rpm	MaXX: 297 @ 3200rpm	320 @ 2000rpm
Gear ratios	5sp Auto	5sp Auto	5 sp Man
1st	4.575	4.575	3.820
2nd	2.979	2.979	1.970
3rd	1.947	1.947	1.304
4th	1.318	1.318	0.971
5th	1.00	1.00	0.767
Final drive ratio	2.700	2.397	4.357
Fuel economy (L/100km)^	SX, CX, LX: 11.5	MaXX: 11.6	8.7

Figures as per ECE regulations

^ Fuel consumption figures based on ADR 81/01 tests. These figures are provided to assist you in comparing the fuel consumption of Captiva with other vehicles. The actual fuel consumption will depend, however, on many factors, including your driving habits, the prevailing conditions and your vehicle's equipment, condition and use

	SX_CX_LX_MaXX
Recommended petrol octane rating	91 (ULP) 95 (PULP for slightly higher performance)
Fuel tank (L)	65
All Wheel Drive (AWD)	The All Wheel Drive system is 'Active Torque On Demand'. An electronically controlled electro-hydraulic differential ensures the best possible torque distribution between the front and rear axles. As driving conditions dictate, the rear axle is employed via an electronically controlled electro-magnetic coupling to give increased traction. The torque split ratio between front and rear wheels is variable in real time depending on the driving conditions
Brakes	Four wheel disc. Ventilated discs – front and rear
Anti-lock Braking System (ABS)	4-channel, 4 sensor
Traction Control System (TCS)	When sensors detect imminent wheel spin, engine torque is reduced. If one wheel starts to spin, braking is applied to transfer torque to the wheel(s) with better traction
Brake Assist (BA)	Provides additional braking assistance by allowing the driver to reach the ABS threshold sooner and therefore help to reduce stopping distances
Electronic Stability Program (ESP®)	Assists the driver in emergency situations by providing correction to the intended vehicle path, which may help the driver to avoid obstacles and reduce slides. This is accomplished via individual brake application and engine torque control. ESP is a registered trademark of Daimler Chrysler AG
Descent Control System (DCS)	Utilises the active braking capability of the ESP® to maintain a controlled speed when travelling down hill
Active Rollover Protection (ARP)	ARP is designed to reduce the risk of rollover when lane changing and cornering; working in conjunction with the ESP® system
Suspension	Front: MacPherson Strut, gas pressurised dampers, stabiliser bar Rear: Independent four-link, gas pressurised dampers, stabiliser bar
Level Ride Suspension	Self contained load-sensitive rear shock absorbers that automatically adjust to load and road conditions
Steering	Rack and pinion power steering
Brakes	Front Diameter: 296mm Rear Diameter: 303mm
Track (mm)	Front: 1562 Rear: 1572
Turn circle (kerb to kerb, m)	SX, CX, LX: 11.5 MaXX: 12.4
Wheelbase (mm)	SX, CX, LX: 2707 MaXX: 2707
Exterior dimensions (mm)	Length Width (excluding mirrors) Width (including mirrors) Height
SX, CX, LX	4637 1849 2110 1720
MaXX	4570 1850 2085 1700
Ground Clearance (mm)	SX, CX, LX: 200 MaXX: 200
Off road (degrees)	Approach angle Departure angle Breakover angle
SX, CX, LX	24.4 22.2 17.8
MaXX	24.2 23.3 17.8
Interior dimensions (mm)	Leg Shoulder Head Hip
SX, CX, LX Front	1036 1454 1026 1349
SX, CX, LX Rear	939 1455 1017 1357
MaXX Front	1036 1424 1026 1338
MaXX Rear	939 1422 1003 1344
Roof Load (kg)	SX, CX: 50 LX, MaXX: 75
Cargo volume seats up/folded (L)	SX (5 seats) CX, LX (7 seats) MaXX (5 seats)
all seats up right	465 85 430
3rd row seats folded	– 465 –
all rear seats folded	930 930 865
front passenger, all rear seats folded	1565 1565 n/a
Towing (kg)	750kg unbraked 2000kg braked Diesel Automatic: 1700kg braked
Service	3,000km (at no cost) inspection, 15,000km then every 15,000km or 12 months, whichever comes first. Holden Dealer 'Tech 2' computerised analysis available for engine management system

SX, CX, LX

dimensions (mm)

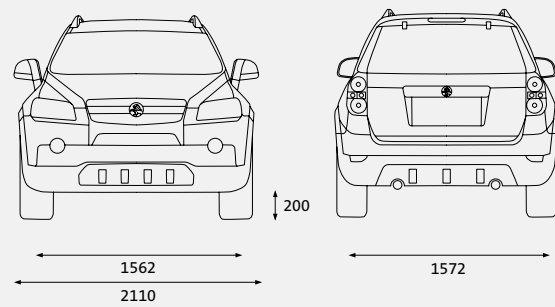
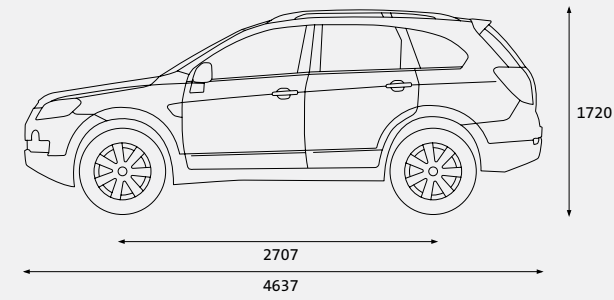

MaXX

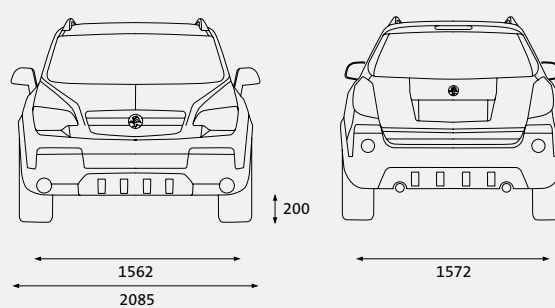
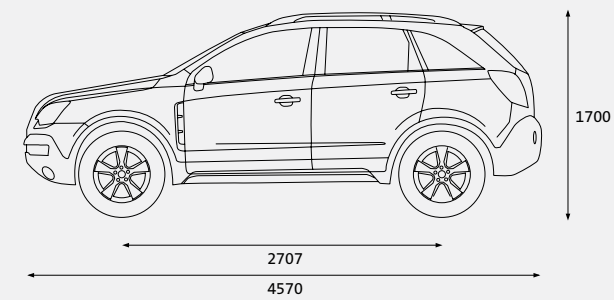

5 seats SX, MaXX

7 seats CX, LX

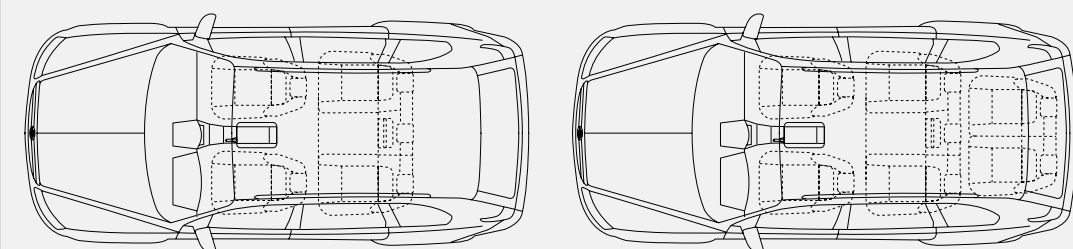

model

exterior colours

	Arctic White	Mercury Silver	Granada Black	Merlot	Midnight Blue	Zest	Chino	Dark Denim Grey	Silverstone Grey
SX	•	•	•	•	•	•	•	•	•
CX	•	•	•	•	•	•	•	•	•
LX	•	•	•	•	•	•	•	•	•
MaXX	•	•	•	•	•	•	•	•	•

seating

SX	cloth
CX	cloth
LX	leather
MaXX	leather

cloth trim Charcoal



leather trim Charcoal



Variations between colours shown and actual paint colours/interior trim colours may occur due to the printing process. Actual vehicle colours may appear different under certain light conditions. Trim patterns are not to scale. Indicative only. Metallic paints are available at an additional cost.

exterior colours



Arctic White



Mercury Silver Metallic



Granada Black Metallic



Merlot Metallic



Midnight Blue Metallic



Zest Metallic



Chino Metallic



Dark Denim Grey Metallic



Silverstone Grey Metallic (Captive MaXX only)