



Aus Liebe zum Automobil

# The Multivan





**Freedom is more than an idea.  
Freedom is the sum of all possibilities.**



**04 – 13**  
Interior space concept.  
Multifunctionality.



**14 – 25**  
Driving comfort.  
Vehicle technology.



**26 – 39**  
Equipment lines.  
Versatility.



**40 – 63**  
Equipment.  
Technical data.





**Room for 7 persons.  
And plenty of personality.**

The Multivan stands for maximum mobility. It is more spacious, more flexible, and more versatile than any other saloon – and has the handling characteristics of a passenger car. It offers drivers and passengers alike tremendous comfort and convenience in every situation. Life is always on the move and the adaptable Multivan is geared to this like no other vehicle.



- 01 rail system in the passenger compartment
- 02 3-seater bench seat
- 03 variable luggage compartment



## It is always the right time for change in the Multivan.

The swimming pool is closed. Why not just drive to the coast? Things often turn out differently from what we expect. The Multivan offers seven comfortable seats, ample stowage space and therefore plenty of room and flexibility to fit in with all your plans. The seats in the passenger compartment can be adjusted almost infinitely on a smooth-running rail system. This makes the interior tremendously versatile – so that it has enough space for all your short trips and long journeys. Everyone has a say in the Multivan – travel plans can be discussed around the practical multi-function table. Digital Voice Enhancement, available as an option, transmits speech between the cab and passenger compartment. Your mobile phone can also be combined with this system so that all occupants can take part in your round table talks.



- 01 single seat in passenger compartment
- 02 drawer in single seat
- 03 multiflex board incl. upholstered padding



01



02



03



**You will notice that it offers more even with your eyes closed.**

You are always on the right track in the Multivan. The innovative interior stowage concept ensures that there is a place for everything you need for relaxing travel. The Multivan is well prepared for long journeys too. The swivelling and folding single seats and 3-seater bench seat can easily be converted into a comfortable surface for resting and sleeping. This surface can be made even larger with the optional multiflex board. The “Good Night package” of your dreams, offered as an option, has curtains to darken the interior and a sleeping cover for the 3-seater bench seat. And when you wake up the next morning after a good night’s sleep you will know that wherever you are travelling in your Multivan you are heading for relaxation.





**You are the centre of attention in the Multivan  
which is why we focus on safety.**



- 01 ISOFIX child's seat mounting points
- 02 driver's air bag
- 03 ESP incl. brake assist system



**The Multivan has room for a great deal.  
Including plenty of safety.**

Whatever your destination and whoever you take with you: maximum safety is your constant companion in the Multivan. The standard safety package includes the electronic control systems ABS, EDL, TCS, ESP incl. brake assist system, and EBC (EBC is not combined with 4MOTION®). They automatically give support to the driver in critical driving situations by intervening in the brake or engine management system within a fraction of a second. Additional protection is provided in the cab by front, side and curtain air bags. As children need the greatest possible safety, there are ISOFIX child's seat mounting points on all single seats in the passenger compartment and on the outer seats of the 3-seater bench seat. In addition, up to four integral child's seats designed to grow with the child can be ordered for the single seats in the passenger compartment. There is therefore big protection for small passengers in the Multivan.

Please contact your local Volkswagen Commercial Vehicle Dealer for details of the standard equipment and optional extras applicable in your country.





**What's it like to drive with so much flexibility?  
Just like driving a saloon.**



- 01 multi-function display/on-board computer
- 02 automatic selector lever
- 03 de luxe seats in cab



## A few reasons why driving is more fun than being driven.

Agile cornering, brisk overtaking: the easy handling of the Multivan creates a passenger car driving experience. Several running gear options are offered – including sports suspension with firm matching, also lowered running gear which makes it easier to drive into underground car parks. The cockpit too is optimally matched to the requirements of the driver. The ergonomic driver's seat has lavish upholstery, and the clearly arranged instrument panel gives an excellent view of all displays. The Radio Navigation System with colour display and DVD player, available as an option, offers dynamic route guidance and CD changer control. The acoustically disengaged running gear ensures that hardly any noise penetrates the interior. Don't let those travelling with you hear any of this – unless you want to take a long break from driving.





**Life leads in many different directions.  
Enjoy every single one.**



- 01 4-cylinder 1.9 l TDI® engine
- 02 5-cylinder 2.5 l TDI® engine
- 03 V6 emblem



## Fuel consumption/CO<sub>2</sub> emission.

With manual gearbox, fuel consumption (litres/100 km) and combined CO<sub>2</sub> emission (g/km), tank contents approx. 80 litres

Engine	2.0 l petrol 85 kW  front-wheel drive	3.2 l V6 petrol 173 kW  4MOTION®	1.9 l TDI® 75 kW without DPF/ with DPF front-wheel drive	2.5 l TDI® 96 kW with DPF front-wheel drive	2.5 l TDI® 96 kW with DPF 4MOTION®	2.5 l TDI® 128 kW with DPF front-wheel drive	2.5 l TDI® 128 kW with DPF 4MOTION®
urban	13.8 – 13.8	18.7 – 18.7	9.6 – 9.6 / 9.8 – 9.8	11.0 – 11.0	11.9 – 11.9	10.8 – 10.8	12.1 – 12.1
extra-urban	8.6 – 8.6	10.4 – 10.4	6.7 – 6.7 / 6.9 – 6.9	6.9 – 6.9	7.7 – 7.7	7.4 – 7.4	7.9 – 7.9
combined	10.6 – 10.6	13.4 – 13.4	7.7 – 7.7 / 7.9 – 7.9	8.4 – 8.4	9.2 – 9.2	8.6 – 8.6	9.4 – 9.4
CO <sub>2</sub> emission combined	254 – 254	322 – 322	208 – 208 / 213 – 213	227 – 227	248 – 248	232 – 232	254 – 254

With automatic gearbox and Tiptronic, fuel consumption (litres/100 km) and combined CO<sub>2</sub> emission (g/km), tank contents approx. 80 litres

Engine		3.2 l V6 petrol 173 kW  front-wheel drive		2.5 l TDI® 96 kW with DPF front-wheel drive		2.5 l TDI® 128 kW with DPF front-wheel drive	
urban		18.2 – 18.2		12.7 – 12.7		12.9 – 12.9	
extra-urban		9.9 – 9.9		7.9 – 7.9		8.1 – 8.1	
combined		12.9 – 12.9		9.6 – 9.6		9.8 – 9.8	
CO <sub>2</sub> emission combined		310 – 310		259 – 259		265 – 265	

## What our engineers have instilled in our engines? That very good performance puts you ahead.

You will get ahead with our engines in every sense of the word. There is a choice of three high-torque TDI® engines: a 1.9 l 75 kW (102 bhp) TDI® with 5-speed manual gearbox; a 2.5 l 96 kW (130 bhp) TDI® with 6-speed manual or 6-speed automatic gearbox; and a 2.5 l 128 kW (174 bhp) TDI® engine with 6-speed manual or 6-speed automatic gearbox. Alternatively you can choose one of the two up-to-date petrol engines: a 2.0 l 85 kW (115 bhp) unit with 5-speed manual gearbox or a 3.2 l 173 kW (235 bhp) petrol engine with 6-speed automatic gearbox. You will notice the effect of the engines immediately – by lower fuel consumption and shorter journeys. Time flies when you are driving the Multivan – performance always pays off.

The figures listed have been established in accordance with the measuring method stipulated (the version of directive 80/1268/EEC which is currently valid).

### Note in accordance with directive 1999/94/EC

Fuel consumption and CO<sub>2</sub> emission are influenced not only by the vehicle's efficient use of fuel but also by the mode of driving and other non-technical factors. CO<sub>2</sub> is the greenhouse gas mainly responsible for global warming.

A guide on the fuel consumption and CO<sub>2</sub> emission of all new passenger car models offered in Germany is available free of charge at every point of sale in Germany where new passenger cars are displayed or on offer.





- 01 wading depth: 300 mm  
at a max. of 30 kph
- 02 ramp angle: 14°
- 03 angle of approach: 22°;  
angle of departure: 16°



You will get ahead with our engines in every sense of the word. There is a choice of three high-torque TDI® engines: a 1.9 175 kW (102 bhp) TDI® with 5-speed manual gearbox; a 2.5 196 kW (130 bhp) TDI® with 6-speed manual or 6-speed automatic gearbox; and a 2.5 128 kW (174 bhp) TDI® engine with 6-speed manual or 6-speed automatic gearbox. Alternatively you can choose one of the two up-to-date petrol engines: a 2.0 185 kW (115 bhp) unit with 5-speed manual gearbox or a 3.2 173 kW (235 bhp) petrol engine with 6-speed automatic gearbox. You will notice the effect of the engines immediately – by lower fuel consumption and shorter journeys. Time flies when you are driving the Multivan – performance always pays off.

## The best way to take everything in your stride: permanent all-wheel drive.

Why not take the short cut across the gravel road? This is another challenge that can be met by the Multivan. When equipped with the option of 4MOTION® drive plus an electronic differential lock and Haldex coupling it is an ideal combination of MPV and offroad vehicle. It masters even difficult road surfaces and gradients of up to 36°, and lets you experience driving dynamics that are unparalleled in this vehicle category. Electronically controlled distribution of drive between the front and rear axle, improved traction and sports suspension help the Multivan to cope with both roads and tracks in rain, snow, ice and slush. Take the gravel road for a change – you'll appreciate the difference.





**Three models that offer you all possibilities  
and complete freedom.**





## The Multivan Trendline.

The Multivan Trendline is a practical companion for all your plans. The standard specification offers seating for six and a generously sized, versatile interior – for short trips with several passengers or your bulk shopping. The comfortable and convenient equipment features ensure that the driver and passengers enjoy relaxing travel at all times.





## The standard equipment of the Multivan Trendline.

### Exterior equipment

- Colour-keyed door mirror housings and door handles
- Front headlights: clear glass halogen headlights with single reflector optics
- Sliding door on right-hand side, with child-proof lock
- Four 6 J x 16 steel wheels with full wheel trim
- Colour-keyed bumpers and tailgate handle
- Heat-insulating windows
- Roof mounting points for roof carrier system

### Safety equipment

- Safety package with ABS, EDL, TCS and EBC (EBC is not combined with 4MOTION®)
- ESP incl. brake assist system
- Air bag system: front, side and curtain air bags in cab, facility in glove compartment to deactivate front passenger's air bag
- Side-mounted turn signals
- Brake lining wear indicator
- Dual tone signal horn
- Three-point inertia reel seat belts on all seats
- ISOFIX child's seat mounting points on single seat in passenger compartment and outer seats of 3-seater bench seat
- Lashing eyes, four in passenger compartment and two in luggage compartment
- Immobiliser, electronic

### Operating equipment

- Door mirrors, electrically adjustable and heated
- Electric windows in driver's and in front passenger's door
- Two luggage compartment lights
- Rear window wash/wipe system with intermittent wipe
- Heating system, can be operated separately, in passenger compartment
- One interior light and two reading lights in cab
- Four interior lights and four reading lights in passenger compartment
- Instrument cluster with electronic speedometer, odometer, trip recorder, rev counter, digital clock, fuel gauge, coolant temperature display, washer fluid level display, warning lamps and maintenance interval display
- Joystick gear lever in instrument panel
- Air conditioner with manual control in cab
- Steering column with height and rake adjustment
- Radio aerial in right-hand rear side window
- Windscreen wipers with intermittent wipe
- Power assisted steering
- Tyre mobility set (12 V compressor, tyre sealing agent)

- One 12 V socket in passenger compartment, one MagCode socket in luggage compartment, one illuminated 12 V socket in cab
- Step lighting with MULTIVAN lettering
- Warning buzzer – is activated if lights are left switched on
- Central locking with radio wave remote control and anti-theft security for all doors and the tailgate, interior operation on driver's door, 2-door operation and provision for selective opening of driver's door, fuel flap is secured by locking the driver's door

### Interior equipment

- Storage compartment with swivelling lid, on centre of instrument panel
- Storage compartment below centre of instrument panel, folds out, with bottle holder
- Stowage concept in passenger compartment: six cup holders, waste container, storage compartments, drawers
- Pockets on reverse of front backrests
- Two cup holders in cab
- Single seat in passenger compartment, longitudinal adjustment, swivelling, removable and folding
- Four grab handles with coat hooks in passenger compartment
- Luggage compartment cover (not in conjunction with multiflex board)
- Glove compartment, lockable, illuminated, can be cooled
- Heating and ventilation system with dust and pollen filters, four-speed fan, recirculating air switch, footwell outlets in cab and additional heat exchanger in passenger compartment, four adjustable vents and defroster outlets for windscreen and side windows
- Folding table in left-hand side panel
- De luxe seats for driver and front passenger, height-adjustable, longitudinal adjustment, each with two armrests and lumbar support
- Sliding window on left
- Four rails in passenger compartment for almost infinite longitudinal seat adjustment
- 3-seater bench seat, folding backrest, with resting/sleeping surface function, integral 3-point inertia reel seat belts and three head restraints, the centre head restraint can be lowered
- Sun blinds on side windows in passenger compartment
- "Corner" pattern cloth seat upholstery
- Plastic floor covering in passenger compartment
- Storage pockets on doors





## The Multivan Comfortline.

The Multivan Comfortline has seating for seven as standard. And plenty of space for all those who want to get things moving or who like to be out and about. The practical multi-function table is only one example of the tremendous versatility and extra possibilities it offers you. After all, being on the move also means always discovering something new.





**Standard equipment of the Multivan Comfortline over and above that of the Multivan Trendline.**

**Exterior equipment**

- Four 6.5 J x 16 "MIYATO" alloy wheels
- Two sliding doors with child-proof locks
- Colour-keyed lateral rubbing strips

**Operating equipment**

- Two ventilation strips in headlining of passenger compartment
- Heating for driver's and for front passenger's seat
- Multi-function display

**Interior trim**

- Aluminium design inserts on instrument panel, interior door panels and side panel trim
- 2nd single seat in passenger compartment: swivelling, longitudinal adjustment, removable and folding, with integral 3-point inertia reel seat belt and ISOFIX child's seat mounting points
- Sliding window on right
- Carpeting in passenger compartment
- Steering wheel and gear/selector lever covered with smooth napa leather; gaiter made of leatherette







## The Multivan Highline.

You are safe on the road and at ease in every society in the Multivan Highline. This MPV stands for complete mobility, flexibility and a refined ambience. The careful attention to detail in the interior creates a pleasant, relaxed atmosphere surrounded by a discreetly elegant outward appearance. Personality is simply shaped by inner values.





**Standard equipment of the Multivan Highline over and above that of the Multivan Trendline.**

**Exterior equipment**

- Four 7 J x 16 "L. A." alloy wheels
- Dark-tinted side windows in passenger compartment
- Two electrically driven sliding doors with child-proof locks and radio wave remote control: on request, can be ordered without this feature at a reduced price
- Colour-keyed lateral rubbing strips
- Fog lights

**Operating equipment**

- Two ventilation strips in headlining of passenger compartment
- "Climatronic"
- Anti-theft warning system with interior monitoring and tilt sensor
- Cruise control
- Electric servo closing of tailgate
- Automatically dimming rear view mirror
- Instrument cluster: cockpit with six chrome ring instruments for following functions: rev counter, speedometer, coolant and oil temperature display, fuel gauge and alternator voltage display. Central dot matrix display for additional vehicle information
- Rain sensor
- Heated windscreen washer jets
- Heating for driver's and for front passenger's seat
- Step lighting with HIGHLINE lettering

**Interior equipment**

- Burr wood inserts on instrument panel, interior door panels and side panel trim
- 2nd single seat in passenger compartment, swivelling, with longitudinal adjustment, removable and folding, with integral 3-point inertia reel seat belt and ISOFIX child's seat mounting points
- Multi-function table, in separate rails, with pivoting tabletop, cup holders, storage compartments and ashtray instead of the folding table
- Loading edge trim and four stainless steel step inserts
- Leather/Alcantara trim
- Steering wheel, handbrake grip and gear/selector lever covered with smooth napa leather; gaiter made of leatherette
- Folding centre armrest on 3-seater bench seat
- Sliding window on right
- Carpeting in passenger compartment
- Clothes hooks in luggage compartment





A close-up, high-angle shot of the front left corner of a silver Volkswagen SUV. The image focuses on the headlight, the multi-slatted grille, and the prominent circular Volkswagen logo badge. The car's body panels are smooth and metallic, reflecting light. The background is a dark, gradient surface.

**The freedom to decide yet remain flexible.  
Equipment and technical data.**



# Exterior equipment.



**Front headlights**

Clear glass halogen headlights with single reflector optics. A headlight cleaning system can be integrated as an optional extra.



**Full wheel trim**  
Full wheel trim for 16" steel wheel.



**Fog lights**

The fog lights are integrated in the bumper.



**6.5 J x 16 alloy wheels**  
16" "MIYATO" alloy wheels, 215 x 65 R16 C. They are not available for models with 3.2 l V6 petrol engine.



**Side windows in passenger compartment, dark-tinted**

Windows with dark-tinted glass screen the interior from view.



**7 J x 16 alloy wheels**  
16" "L. A." alloy wheels, 235 x 60 R16. They are not available for models with 3.2 l V6 petrol engine.



**Heat-insulating windows**

Windows with green-tinted glass reduce heating up of the interior due to solar radiation.



**7 J x 17 alloy wheels**  
17" "SOLACE" alloy wheels, 235 x 55 R17. Available for models with 5-cylinder TDI® engine. They are standard on the Multivan Comfortline and Highline with V6 petrol engine.



Please contact your local Volkswagen Commercial Vehicle Dealer for details of the standard equipment and optional extras applicable in your country.

standard
  optional extra
  Multivan Trendline
  Multivan Comfortline
  Multivan Highline



# Interior equipment.



**Partial leather trim**  
The gear knob is covered with smooth napa leather, and the gear lever gaiter is made of leatherette. In the Highline model, the handbrake grip is also covered with smooth napa leather.



**Side panel trim**  
The side panel trim is colour coordinated to match the seat upholstery.



**Control unit for door mirrors, windows and central locking**  
The control unit is in the driver's door.



**3-seater bench seat, folding centre armrest, leather**  
The 3-seater bench seat with leather/Alcantara or leather/leather trim has a folding centre armrest.

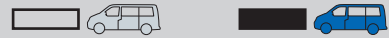

**Headlining**  
Two ventilation strips with integral reading lamps and climate control are fitted in the headlining of the passenger compartment.



**Storage compartments**  
One storage compartment with pivoting lid is on the centre of the instrument panel; and another compartment, with bottle holder, underneath the centre of the instrument panel.



**Glove compartment, illuminated**  
The lockable glove compartment with cooling facility on the front passenger's side provides space for items needed during the journey.



Please contact your local Volkswagen Commercial Vehicle Dealer for details of the standard equipment and optional extras applicable in your country.

standard
  optional extra
  Multivan Trendline
  Multivan Comfortline
  Multivan Highline



## Interior equipment.



### Folding table

The practical folding table in the Multivan is integrated in the left-hand side panel and can be folded out as required. The table must remain folded down during the journey. Available as an option at a reduced price for the Multivan Comfortline.

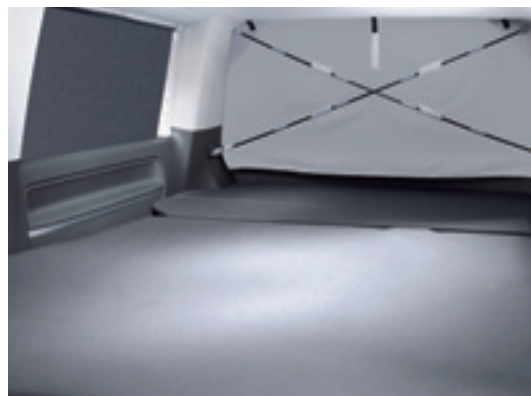
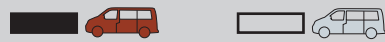

### “Good Night package”

This package consists of curtains to darken the interior and a sleeping cover for the 3-seater bench seat.



### Multiflex board

The multiflex board plus padding available as an option is secured in the rail system. It subdivides the luggage compartment, creates an additional stowage surface, and augments the “Good Night package”. If the multiflex board is ordered, there is then no luggage compartment cover.



### Insulated box

The insulated box available as an option has electrical operation and can keep food and drinks cool or warm. It has a capacity of 32 l. There is sufficient height for 1 litre bottles to stand in the box; 1.5 litre bottles can be placed flat.



## Safety equipment.

### Integral child's seat

On request the Multivan can have up to four integral child's seats in the passenger compartment. They are available in all seat upholstery patterns and can be used as normal seats or to protect children between nine months and twelve years of age. The seats are equipped with an integral seat cushion and a special 5-point belt system for optimal restraint.

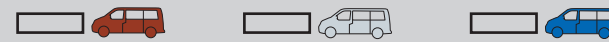

### ISOFIX child's seat mounting points

The ISOFIX child's seat mounting points are in the single seats in the passenger compartment and in the outer seats of the 3-seater bench seat. These enable child's seats to be securely connected to the vehicle structure.

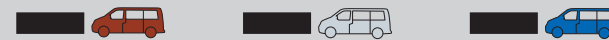

### Net partition for luggage

The net partition for luggage can be attached to the securing points behind the B pillar or in front of the D pillar.

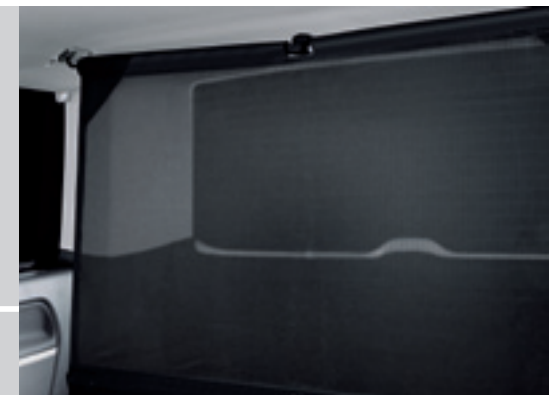
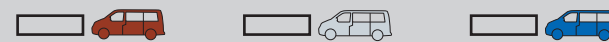

### Lashing eyes

There are four lashing eyes in the passenger compartment and two in the luggage compartment for securing luggage/load.

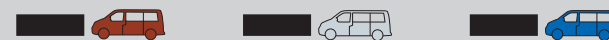

Please contact your local Volkswagen Commercial Vehicle Dealer for details of the standard equipment and optional extras applicable in your country.

standard

optional extra

Multivan Trendline

Multivan Comfortline

Multivan Highline



# Operating equipment.



### Digital Voice Enhancement (DVE)

Microphones in the headlining of the cab and passenger compartment facilitate conversations between the driver, front passenger and other passengers. The sound system is used for speech transmission. Digital Voice Enhancement is available in conjunction with the Radio Navigation System and sound system, or with a Delta radio and sound system. If a hands-free mobile phone system is integrated, this too is combined with DVE.



### Navigation system

The DVD Radio Navigation System with colour display features dynamic route guidance and CD changer control. The DVD contains maps for many countries in Europe. An AUX IN socket is provided enabling external audio sources such as an MP3 player to be connected to the system.



### Delta radio

The Delta radio is an RDS radio with integral CD player, eight loudspeakers, individually adjustable sound fields and monochrome display. The CD changer and sound system available as options can be operated via the radio.



### Sound system

The sound system offers an additional amplifier and a subwoofer on the left-hand side of the side panel trim at the rear.



### Car phone

The "Siemens S65" or "Nokia 6021" mobile phone is supplied if there is provision for the installation of a phone with integral hands-free facility. On request, provision for the installation of a phone is available without a mobile phone. The illustration shows the "Siemens S 65" mobile phone.



### "Climatronic"

The 3-zone electronic air conditioner utilising residual heat has one control display each for the driver, front passenger, and passenger compartment for individual temperature adjustment.



Please contact your local Volkswagen Commercial Vehicle Dealer for details of the standard equipment and optional extras applicable in your country.

standard
  optional extra
  Multivan Trendline
  Multivan Comfortline
  Multivan Highline



## Operating equipment.



### Auxiliary heater/additional coolant heater

The auxiliary heater works independently of the heating and ventilation system and is available either with or without radio wave remote control. An additional coolant heater is also available on request.



### Step lighting

Step lighting with MULTIVAN lettering. Individual lettering for the step lighting can be retrofitted on request.

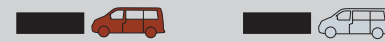

### Rear view mirror, automatically dimming

The rear view mirror has photocell control. It dims automatically when the headlights of the car behind are too bright.



### Step lighting

Step lighting with HIGHLINE lettering. Individual lettering for the step lighting can be retrofitted on request.

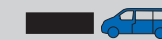

### Sliding/tilting roof

The sliding/tilting glass roof with integral sun protection in the cab can be operated via automatic pre-selection.



### MagCode socket

The Multivan offers a MagCode socket as standard. It is in the load compartment, is short-circuit proof, watertight and easy to clean. If the insulated box available as an extra is ordered, there is an additional MagCode socket on the front passenger's seat.

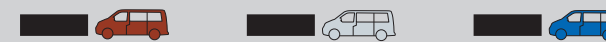

### Sun blinds

The integral sun blinds are fitted on the side windows of the passenger compartment. They reduce heating up of the interior and protect against dazzle.



### Anti-theft warning system

The anti-theft warning system is activated via door contacts or movement sensors inside the vehicle. The Highline model has a tilt sensor with tow-away warning.

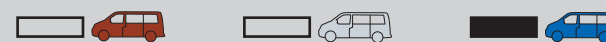

Please contact your local Volkswagen Commercial Vehicle Dealer for details of the standard equipment and optional extras applicable in your country.

■ standard

□ optional extra

Multivan Trendline

Multivan Comfortline

Multivan Highline



## Operating equipment.



### Parking distance warning

Acoustic signals from the ultrasound sensors fitted in the front and rear bumper make parking easier.



### Detachable tow bar

The max. trailer weight for vehicles with a 1.9 l TDI® engine\* is 2.2 t; 2.0 t for models with a 2.0 l petrol engine\*; and 2.5 t for models with a 2.5 l TDI® or V6 petrol engine\*. Vehicles with ESP have, in addition, trailer stabilisation.



### Headlight cleaning system

The system works when low or high beams are switched on. It is linked to the windscreen washer system so that the headlight lenses are cleaned every 5th time the windscreen is cleaned.



### Interior cycle carrier

The modular interior cycle carrier for two, three or four bicycles is mounted in the outer rails in the luggage compartment. It is still possible to use the 3-seater bench seat when this interior cycle carrier is fitted.



## Volkswagen Genuine Accessories.

### Cycle carrier for the tailgate

Can transport a maximum of four bicycles. Made of anodised aluminium profile bars, with fasteners. Pre-assembled and therefore very easy to fit. Does not impair tailgate opening function. Net weight 13 kg. Carrying capacity 60 kg.

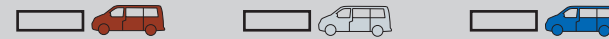

### Basic carrier

This is the basis for all attachments – from surfboard holders to roof boxes. Made of aerodynamically shaped aluminium profile bars with plastic cover caps. Theft-deterrent fasteners. Net weight approx. 5.6 kg. City crash tested.

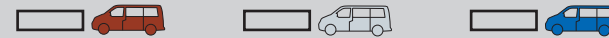

### Basic carrier with surfboard holder

For the convenient transport of up to two surfboards. Includes two mast holders and two tensioning straps, and can be fitted easily and quickly on the basic carrier.

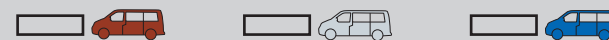

\*Please refer to page 58 for information on CO<sub>2</sub> emission and fuel consumption.

Please contact your local Volkswagen Commercial Vehicle Dealer for details of the standard equipment and optional extras applicable in your country.



# Volkswagen Genuine Accessories.



## Basic carrier with ski and snowboard holder

For the safe transport of up to six pairs of skis or up to four snowboards. The holder is lockable and has a practical pull-out function for ease of loading and unloading.



## Coat hanger

The special car coat hanger can be secured to the rods of a head restraint and helps to keep clothes from becoming creased or crumpled.



## Basic carrier with ski and luggage box

Additional luggage can be stowed in the aerodynamic roof box made of high-grade plastic. A T-track system enables the box to be fitted securely on the basic carrier. The lockable box can be opened from either side. The wide opening angle helps to take the effort out of loading. Exterior dimensions: 190 x 90 x 38 cm. Weight: approx. 25 kg. Capacity: 450 litres.



## Luggage net

The tear-proof luggage net has securing hooks. These enable it to be fastened to the lashing eyes in the luggage compartment to prevent light loads and luggage from slipping.

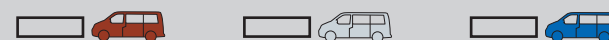

## Bobsy G0 child's seat plus ISOFIX

This child's seat is suitable for infants up to approx. 15 months old or weighing up to 13 kg. The ISOFIX connection is firmly secured to the vehicle structure for maximum safety. A harness gives the child optimum support; additional protection is provided by the high sides and deeper seat.



## Luggage compartment liner

The practical, protective made-to-measure liner can be wiped clean, is non-slip and acid-resistant. The 5 cm raised rim around the edge stops fluids from spilling onto the floor, helps keep the compartment clean, and prevents the load from sliding around.



## Bobsy G1 ISOFIX duo plus child's seat

The child's seat is secured to the ISOFIX mounting points. This results in particularly good stability, and makes it easy to fit and remove the seat. The height of the harness can easily be adjusted and the seat shell can be locked at three different angles. For infants between 8 months and 4 years of age (corresponds with a weight of approx. 9-19 kg).



## 8 J x 18 alloy wheels

8 J x 18 "DAKAR" alloy wheel and size 235/50 R18 101 YXL tyre.

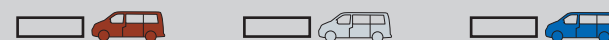

Volkswagen Genuine Accessories are only available at your Volkswagen Dealer. Please contact your local Volkswagen Commercial Vehicle Dealer for details of the standard equipment and optional extras applicable in your country.

standard
  optional extra
  Multivan Trendline
  Multivan Comfortline
  Multivan Highline



# Technical details at a glance.

## Petrol engines

	2.0 l petrol engine (85 kW) <sup>1</sup> (not available for Highline model)	3.2 l V6 petrol engine (173 kW) <sup>1</sup> (not available for Trendline model)
Mixture preparation/injection method	Bosch Motronic ME 7.5	Bosch Motronic ME 7.1.1
No. of cylinders	4	6
Cubic capacity, cm <sup>3</sup>	1,984	3,189
Output, kW at rpm	85 at 5,200	173 at 6,200
Max. torque, Nm/rpm	170/2,700 – 4,700	315/2,950
EU exhaust emission directive	according to 98/69/EC I B, EURO 4	according to 98/69/EC I B, EURO 4
5-speed manual gearbox	standard	–
6-speed manual gearbox	–	standard with 4MOTION®
6-speed automatic gearbox with Tiptronic	–	standard (without 4MOTION®)
4MOTION® (with 6-speed manual gearbox)	–	combination possible
Type of fuel	premium unleaded DIN EN 228, 95 RON	premium unleaded DIN EN 228, 95 RON

## Diesel engines

	1.9 l TDI® engine (75 kW) <sup>1</sup> without/with diesel particulate filter (DPF) (not available for Highline model)	2.5 l TDI® engine (96 kW) <sup>1</sup> with diesel particulate filter (DPF)
Mixture preparation/injection method	unit injector direct injection	unit injection direct injection
No. of cylinders	4	5
Cubic capacity, cm <sup>3</sup>	1,896	2,459
Output, kW at rpm	75 at 3,500	96 at 3,500
Max. torque, Nm/rpm	250/2,000	340/2,000 – 2,300
EU exhaust emission directive	according to 98/69/EC III A, EURO 4 <sup>2</sup>	according to 98/69/EC III A, EURO 4 <sup>2</sup>
5-speed manual gearbox	standard	–
6-speed manual gearbox	–	standard
6-speed automatic gearbox with Tiptronic	–	combination possible
4MOTION® (with 6-speed manual gearbox)	–	combination possible
Type of fuel	diesel, in accordance with DIN EN 590	diesel, in accordance with DIN EN 590

## Diesel engines

	2.5 l TDI® engine (128 kW) <sup>1</sup> with diesel particulate filter (DPF)
Mixture preparation/injection method	unit injector direct injection
No. of cylinders	5
Cubic capacity, cm <sup>3</sup>	2,459
Output, kW at rpm	128 at 3,500
Max. torque, Nm/rpm	400/2,000 – 2,300
EU exhaust emission directive	according to 98/69/EC III A, EURO 4 <sup>2</sup>
5-speed manual gearbox	–
6-speed manual gearbox	standard
6-speed automatic gearbox with Tiptronic	combination possible
4MOTION® (with 6-speed manual gearbox)	combination possible
Type of fuel	diesel, in accordance with DIN EN 590

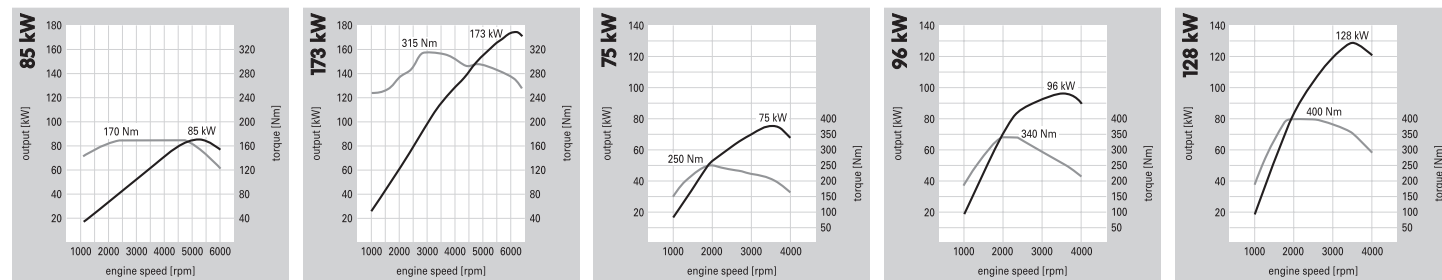

# Weights and dimensions.

## Weights

Engine	Output (kW)	Drive	Gross vehicle weight (kg)	Payload (kg) from-to	Trailer weight braked/unbraked (kg) <sup>1</sup>	Gross train weight (kg) <sup>1</sup>
<b>Multivan (6/7-seater, wheelbase 3,000 mm)</b>						
2.0 l petrol	85	front-wheel	2,850	666 – 451	2,000 / 750	4,500
3.2 l V6 petrol	173	front-wheel	3,000	701 – 486	2,500 / 750	5,200
3.2 l V6 petrol	173	4MOTION®	3,000	601 – 451	2,500 / 750	5,300
1.9 l TDI®	75	front-wheel	3,000	801 – 586	2,200 / 750	4,900
2.5 l TDI®	96 and 128	front-wheel	3,000	726 – 511	2,500 / 750	5,200
2.5 l TDI®	96 and 128	4MOTION®	3,000	626 – 475	2,500 / 750	5,300

## Dimensional drawing<sup>2</sup>

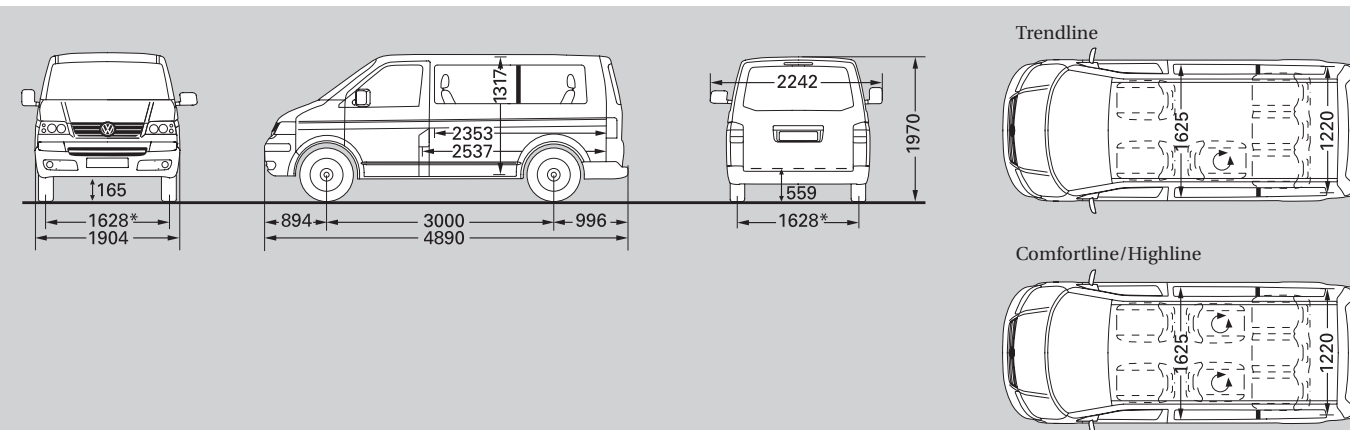

passenger/load compartment, area/volume	4.3 m <sup>2</sup> /4,525 l (volume given is without seats in passenger compartment)
lateral sliding door(s), width/height	1,010/1,253 mm
tailgate, width/height	1,446/1,262 mm
turning circle	11.9 m
*1,620 on 17" running gear	

<sup>1</sup> For 12% gradient.

<sup>2</sup> All measurements listed are based on series vehicles.

Due to production tolerances, tyre sizes and type of running gear the actual dimensions can differ slightly from the figures given here. The vehicle drawings are not to scale.

Additional equipment may alter the unladen weight of the vehicle in which case the payload, performance, fuel consumption and CO<sub>2</sub> emission are affected.

Roof load limit: 100 kg (with two roof carriers) or 150 kg (with at least four roof carriers); trailer nose weight: 100 kg.

<sup>1</sup> Please refer to page 58 for information on CO<sub>2</sub> emission and fuel consumption.

<sup>2</sup> Road tax ratings for passenger cars with diesel engines and a gross vehicle weight exceeding 2.5 t are in accordance with emission key No. 69.



## Fuel consumption/CO<sub>2</sub> emission.

With manual gearbox, fuel consumption (litres/100 km) and combined CO<sub>2</sub> emission (g/km), tank contents approx. 80 litres

Engine	2.0 l petrol 85 kW  front-wheel drive	3.2 l V6 petrol 173 kW  4MOTION®	1.9 l TDI® 75 kW without DPF/ with DPF front-wheel drive	2.5 l TDI® 96 kW with DPF front-wheel drive	2.5 l TDI® 96 kW with DPF 4MOTION®	2.5 l TDI® 128 kW with DPF front-wheel drive	2.5 l TDI® 128 kW with DPF 4MOTION®
urban	13.8 – 13.8	18.7 – 18.7	9.6 – 9.6 / 9.8 – 9.8	11.0 – 11.0	11.9 – 11.9	10.8 – 10.8	12.1 – 12.1
extra-urban	8.6 – 8.6	10.4 – 10.4	6.7 – 6.7 / 6.9 – 6.9	6.9 – 6.9	7.7 – 7.7	7.4 – 7.4	7.9 – 7.9
combined	10.6 – 10.6	13.4 – 13.4	7.7 – 7.7 / 7.9 – 7.9	8.4 – 8.4	9.2 – 9.2	8.6 – 8.6	9.4 – 9.4
CO <sub>2</sub> emission combined	254 – 254	322 – 322	208 – 208 / 213 – 213	227 – 227	248 – 248	232 – 232	254 – 254

With automatic gearbox and Tiptronic, fuel consumption (litres/100 km) and combined CO<sub>2</sub> emission (g/km), tank contents approx. 80 litres

Engine		3.2 l V6 petrol 173 kW  front-wheel drive		2.5 l TDI® 96 kW with DPF front-wheel drive		2.5 l TDI® 128 kW with DPF front-wheel drive	
urban		18.2 – 18.2		12.7 – 12.7		12.9 – 12.9	
extra-urban		9.9 – 9.9		7.9 – 7.9		8.1 – 8.1	
combined		12.9 – 12.9		9.6 – 9.6		9.8 – 9.8	
CO <sub>2</sub> emission combined		310 – 310		259 – 259		265 – 265	

The figures listed have been established in accordance with the measuring method stipulated (the version of directive 80/1268/EEC which is currently valid).

### Note in accordance with directive 1999/94/EC

Fuel consumption and CO<sub>2</sub> emission are influenced not only by the vehicle's efficient use of fuel but also by the mode of driving and other non-technical factors. CO<sub>2</sub> is the greenhouse gas mainly responsible for global warming.

A guide on the fuel consumption and CO<sub>2</sub> emission of all new passenger car models offered in Germany is available free of charge at every point of sale in Germany where new passenger cars are displayed or on offer.

## Performance.

With manual gearbox

Engine	Output (kW)	Drive	Acceleration (kph, s) 0 – 100	Top speed (kph)
2.0 l petrol	85	front-wheel	17.8	163
3.2 l V6 petrol	173	4MOTION®	10.6	206
1.9 l TDI® without/with DPF	75	front-wheel	18.9/18.9	157/157
2.5 l TDI® with DPF	96	front-wheel	15.3	168
2.5 l TDI® with DPF	96	4MOTION®	16.3	165
2.5 l TDI® with DPF	128	front-wheel	12.2	188
2.5 l TDI® with DPF	128	4MOTION®	12.5	184

With automatic gearbox and Tiptronic

Engine	Output (kW)	Drive	Acceleration (kph, s) 0 – 100	Top speed (kph)
3.2 l V6 petrol	173	front-wheel	10.5	205
2.5 l TDI® with DPF	96	front-wheel	15.4	164
2.5 l TDI® with DPF	128	front-wheel	12.3	183

The figures listed here are based on vehicles without additional equipment.

Further technical data of the vehicles we offer is given on the Internet site [www.vwn.de](http://www.vwn.de) where it can be downloaded.



## Paint finishes.

<b>Solid paints</b>	Grey White <b>T7T7</b>	Black <b>A1A1</b>	Summer Blue <b>E1E1</b>	Tornado Red <b>G2G2</b>
	Lint Green <b>V4V4</b>	Sari Yellow <b>4T4T</b>		
<b>Metallic paints</b>	Reflex Silver Metallic <b>8E8E</b>	Shadow Blue Metallic <b>P6P6</b>	Ravenna Blue Metallic <b>SZSZ</b>	Pine Green Metallic <b>9Y9Y</b>
	Off-Road Grey Metallic <b>M3M3</b>	Fresco Green Metallic <b>3P3P</b>	Wheat Beige Metallic <b>D1D1</b>	
	Black Magic Pearl Effect <b>Z4Z4</b>	Murano Red Pearl Effect <b>9W9W</b>		

## Colours for upholstery, interior and leather.

<b>Upholstery colours</b>	Corner Art Grey <b>BV</b>	Corner Blue <b>BW</b>	Art Grey Duo Dessin <b>EH</b>	Anthracite Duo Dessin <b>EJ</b>
	Blue Duo Dessin <b>EL</b>	Red Duo Dessin <b>EK</b>		
<b>Leather colours</b>	Leather Art Grey <b>MV</b>	Leather/Alcantara Art Grey <b>YA</b>	Leather Pure Beige <b>MW</b>	Leather/Alcantara Pure Beige <b>YB</b>
	Leather Anthracite <b>LA</b>	Leather/Alcantara Anthracite <b>VC</b>		
	Anthracite	Art Grey	Pure Beige	

Some of the vehicles shown are equipped with optional extras at extra charge. Decoration contained in the illustrations is not included in the standard specifications. The data given here on specifications, appearance, performance, weights and dimensions, fuel consumption and operating costs of the vehicles is in accordance with the information available at the time of going to print. All details of equipment and technical data are based on the features of the German market. Subject to change without notice. TDI® and 4MOTION® are registered trademarks of companies in the Volkswagen Group in Germany and in other countries. The illustrations on these pages can only be regarded as a general guide as the printing process cannot render the colours with absolute accuracy.



# Seat upholstery.

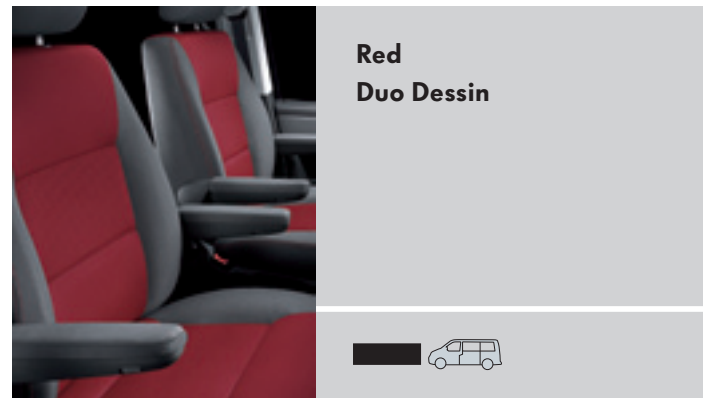
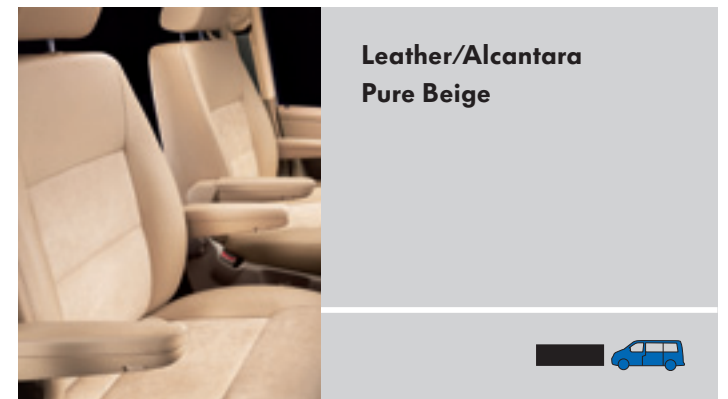
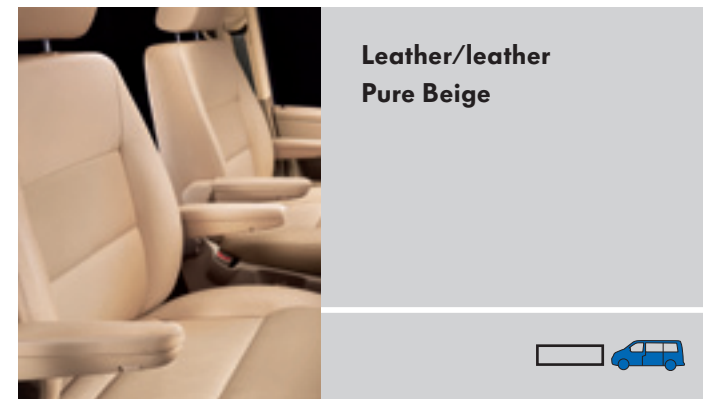
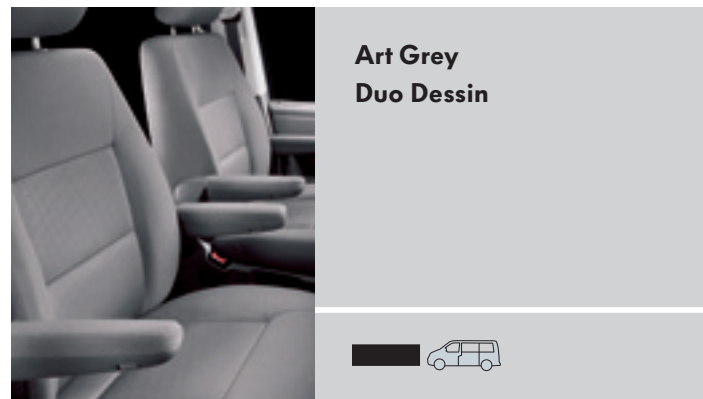
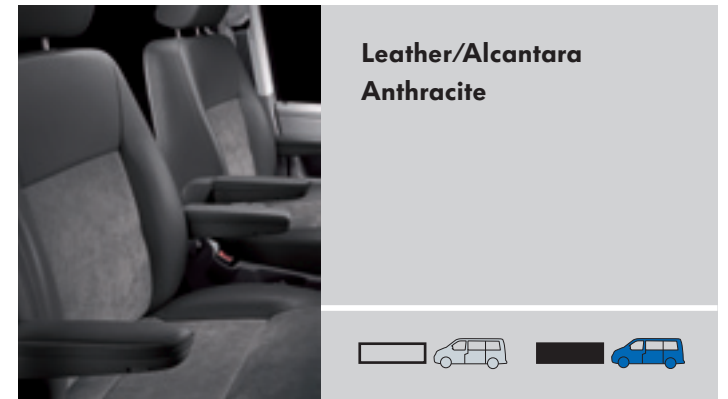
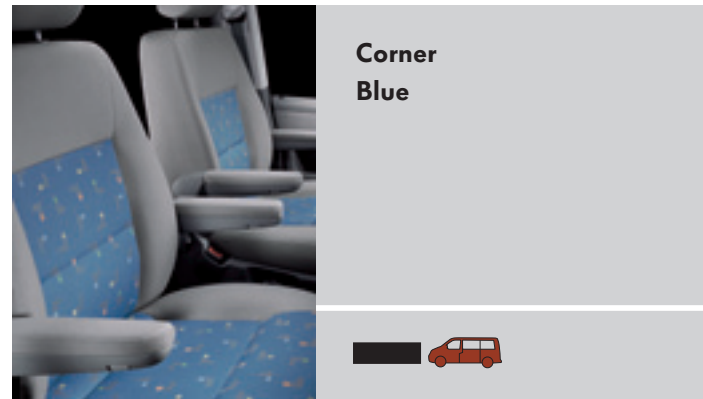
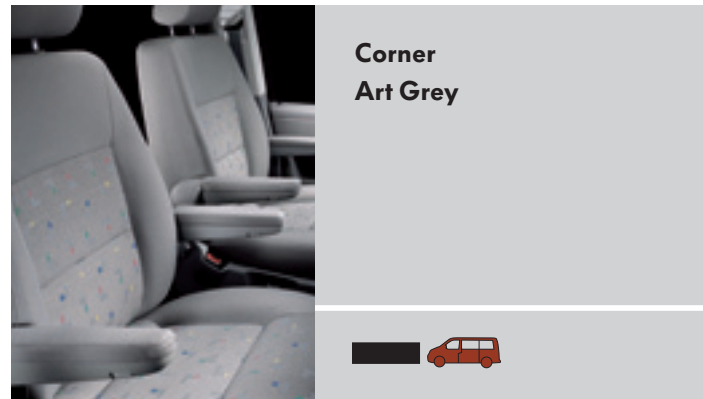

## Combinations of colours.

Interior	Upholstery colours	Grey White	Black	Summer Blue	Tornado Red	Lint Green	Sari Yellow	Reflex Silver Metallic	Shadow Blue Metallic	Ravenna Blue Metallic	Pine Green Metallic	Off-Road Grey Metallic	Fresco Green Metallic	Wheat Beige Metallic	Black Magic Pearl Effect	Murano Red Pearl Effect
		Art Grey	Corner Art Grey	•	•	•	•	•	•	•	•	•	•	•	•	•
	Corner Blue	•	•	•	•	•	•	•	•	•	•	•	•	•	•	•
	Duo Art Grey	•	•	•	•	•	•	•	•	•	•	•	•	•	•	•
	Leather/leather Art Grey	•	•	•	•	•	•	•	•	•	•	•	•	•	•	•
	Leather/Alcantara Art Grey	•	•	•	•	•	•	•	•	•	•	•	•	•	•	•
Anthracite	Duo Anthracite/Anthracite	•	•	•	•	•	•	•	•	•	•	•	•	•	•	•
	Duo Anthracite/Red	•	•	•	•	•	•	•	•	•	•	•	•	•	•	•
	Duo Anthracite/Blue	•	•	•	•	•	•	•	•	•	•	•	•	•	•	•
	Leather/leather Anthracite	•	•	•	•	•	•	•	•	•	•	•	•	•	•	•
	Leather/Alcantara Anthracite	•	•	•	•	•	•	•	•	•	•	•	•	•	•	•
Pure Beige	Leather/leather Pure Beige		•						•	•	•	•	•	•	•	•
	Leather/Alcantara Pure Beige		•						•	•	•	•	•	•	•	•

standard
  optional extra
  Multivan Trendline
  Multivan Comfortline
  Multivan Highline



# The Multivan

665.1192.14.18 • Printed in Germany

Subject to change without notice

Issue: May 2006

Internet: [www.vwn.de](http://www.vwn.de)