



This Brochure is prepared by Daimler AG and it predominantly reflects the capabilities and performance of vehicles sold in Europe. Some characteristics, capabilities, performance features and optional extras (e.g. towing systems) may not be available or may not apply in Australia or under Australian conditions. The information in this Brochure is therefore indicative, illustrative and provided only for guidance and should not be relied on. To obtain current and accurate information on a vehicle and any options applicable to Australia, contact your local authorised Mercedes-Benz dealer.

Mercedes-Benz



Mercedes-Benz

The new-generation **CLS-Class**

From the Mercedes-Benz dream factory

Contents

The CLS	4	My CLS	50
Exterior design	4	Equipment	52
Agility	16	Standard equipment	52
TrueBlueSolutions	16	Optional extras	54
Diesel engines	18	Light-alloy wheels	58
Petrol engines	20	Genuine accessories	60
Transmission	24	Colours and materials	62
AIRMATIC	26	Paint finishes	62
Safety	28	Upholstery and leather	64
AMG	32	Trim elements	66
CLS 63 AMG	32	designo	67
AMG <i>PERFORMANCE STUDIO</i>	35	Possible combinations	70
AMG equipment	37	Technical data	71
Interior comfort	38	Service and test drive	74
Interior – designo	46		

Words cannot do it justice: the sign of a true masterpiece

There are moments in life which take our breath away. Moments, in which we lose ourselves in contemplation of a masterpiece and forget the world around us. The CLS, an inimitable combination of a sporty coupé and a luxurious saloon which is always the focus of admiring looks, is difficult to define in words. It simply has to be experienced.









CLS500



S OU 4664



There's more to true beauty than just the sum of its individual parts



Some designer pieces are better off on the road than in a museum

The expressive lines of the CLS stylishly reconcile the sporty feel of a coupé with the elegance of a classic 4-door saloon. The characteristic side feature line, the dynamic curve of the arching roof and the unmistakable profile lend the CLS a timeless beauty. Its entire appearance is a statement of automotive self-confidence. Quite simply, it is an accomplished combination of agility and comfort. Judicious adjustments to some of its exterior details, meanwhile, now make the design of the CLS more attractive than ever.









Good design begins in
the head of the designer
and ends in the heart of
the observer

Those familiar with the CLS will notice that its face is now even more expressive. The area between the familiar, L-shaped headlamps is now spanned by two louvres, backed by an atlas grey diamond-pattern grille. This design element, which is also to be found in the air intakes in the front bumper, adds discreet emphasis to incisive look of the front section. Arrow-shaped repeater indicators in the exterior mirrors are another eye-catching feature.





The characteristic spoiler lip at the rear provides a fitting conclusion to the distinctive design idiom of the CLS. The stylish lines of the boot lid conceal a luggage compartment which introduces a large measure of every-day practicality to the equation. Trapezoidal exhaust tailpipes and elegantly designed tail lights add the finishing touch to the attractive rear section.

TrueBlueSolutions

Climate change is one of the major challenges of the 21st century. The rising consumption of natural resources is having an increasing impact on our planet. As the inventor of the motor car, Mercedes-Benz has a special responsibility to implement innovative technologies in order to develop solutions that help preserve the environment and ensure that raw materials are used as efficiently as possible – without compromising on comfort, safety and driving enjoyment. We call them TrueBlueSolutions.

Our goal is emission-free mobility. To achieve this goal, we have developed a number of concepts, one of which is **BlueEFFICIENCY**. This custom-designed package of efficiency measures can reduce fuel consumption by up to 12 %: various aerodynamic and energy-management measures are implemented individually for each model to maximise savings in each case. These include tyres with low rolling resistance, lightweight materials, changes to the body aerodynamics and the automatic ECO start/stop function. As for

diesel engines, Mercedes-Benz has brought to market its **BlueTEC** technology based on common-rail direct injection (CDI). This technology is the embodiment of the world's cleanest diesel as it can reduce nitrogen oxides by up to 80 %. Great things are also expected of **BlueHYBRID** technology - a combination of a highly efficient internal combustion engine and an electric motor. Vehicles equipped with this drive system raise the bar once again in terms of economy and cleanliness, as will be shown by the S-Class from 2009 onwards. Mercedes-Benz calls the equivalent technology for diesel vehicles **BlueTEC HYBRID**. A prototype



BlueTEC. The world's cleanest diesel technology in a modern-day vehicle. The E-Class is also available with BlueTEC technology

version of this system can be seen in the Vision GLK 300 BlueTEC HYBRID¹, which is currently the world's cleanest and most economical SUV. It returns a combined consumption figure of just 5.9 l/100 km. And with the F700 research vehicle, we have succeeded in combining the advantages of a petrol engine with those of a diesel powerplant. The **DIESOTTO** drive at the heart of the F700 may have petrol in the tank; however, it operates like an economical diesel model in many driving situations. Mercedes-Benz also sees great potential in the development of the fuel cell. This highly promising drive system requires no



BlueEFFICIENCY. Numerous models, various measures, one goal: maximum efficiency

mineral fuel whatsoever and operates with zero emissions. The first of these vehicles to be built under series-production conditions – the B-Class F-CELL – is due in 2010.

However, our extensive TrueBlueSolutions concept does not just include new drive technologies. Under the banner **Design for Environment**, we look at the vehicle's entire lifecycle – from planning to recycling. The same applies to the building and running of new plants. We save energy, avoid pollutants and increase the use of renewable raw materials. Incidentally, Mercedes-Benz is the



BlueHYBRID. Looking forward to one of the world's most economical luxury saloons. The S-Class from 2009

world's only car brand to have received the independently awarded TÜV² environmental certificate. TrueBlueSolutions also involves the active participation of the Group and its employees in environmental protection measures both inside and outside the company's plants. And it incorporates a commitment to developing second-generation alternative fuels (BTL/Biomass-to-Liquid fuels), such as SunDiesel[®], which are not at odds with food production. Another aspect of TrueBlueSolutions is the research discipline of bionics, which looks at structures and designs in the natural world in order to optimise the



BlueTEC HYBRID. The Vision GLK 300 BlueTEC HYBRID¹ is the most efficient combination of BlueTEC diesel and hybrid modules

weight and aerodynamics of body constructions, for example. Last but not least, you can also do your bit for TrueBlueSolutions by adapting your driving style.

For further information on our extensive package of measures, go to www.mercedes-benz.com/truebluesolutions

¹ Provisional figures: combined fuel consumption: 5.9l/100 km; overall CO₂ emissions: 157 g/km

The figures are not based on an individual vehicle and do not constitute part of the product offer; they are provided solely for purposes of comparison between different vehicle models

² TÜV SÜD Management Service GmbH, Munich



F-CELL. Emission-free mobility with the drive system of the future: the B-Class F-CELL goes into production in 2010



When you invest in a work of art, you should be au fait with the techniques used

There's more to life than just looking good. That's why the impressive CLS engines also deliver outstanding performance. If you want immense pulling power, superb refinement and excellent fuel economy, the CLS 320 CDI with its V6 diesel engine is just the thing. The powerplant develops 165 kW (224 hp) and a peak torque of 540 Nm from 1600 rpm. All of which makes for a pleasing responsiveness when accelerating and impressive pulling power for those spur-of-the-moment intermediate sprints.

CLS 320 CDI

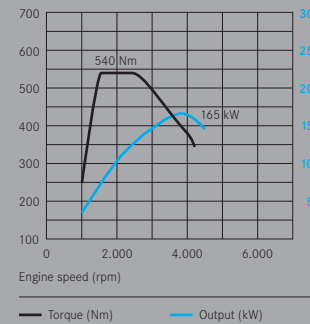

Equipped with the very latest common-rail diesel technology, the V6 engine delivers high torque even at low revs

Looks its best when on the move

It's entirely up to you just how spirited you want your CLS to be. In the petrol range, you can choose from two V6 engines and a V8 power-plant. The entry-level model is the CLS 280 which has an output of 170 kW (231 hp) and impresses with its highly responsive character. Those looking for a combination of sporty flair and innovative engine technology will find the CLS 350 CGI ideal. In this unit, the fuel is injected directly into the combustion chamber under high pressure via special piezoelectric injectors. This results in almost complete combustion of the fuel, thereby reducing exhaust emissions. Although capable of developing an impressive 215 kW (292 hp), the dynamic CLS 350 CGI also offers favourable fuel consumption.

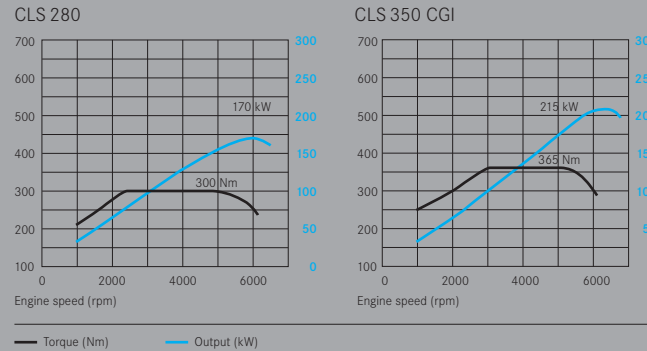

Which of the V6 petrol engines you choose is entirely a matter of personal taste – both offer an impressively comfortable driving experience

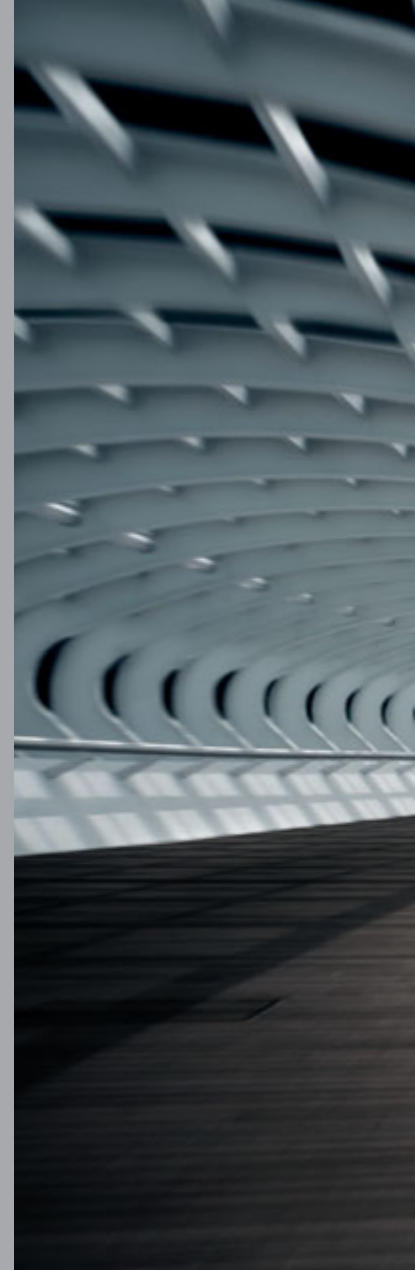





Tastes will always differ. Expectations too

The CLS 500 takes the concept of effortless superiority to even greater heights thanks to its 285-kW (388-hp) V8 engine which makes sporty driving sheer pleasure. With a displacement of 5461 cc, this unit makes its rated torque of 530 newton metres available across a pleasingly broad engine speed range (2800 to 4800 rpm) to deliver thrilling pulling power. But regardless of the engine version you choose, you can always count on the CLS to deliver an extremely agile and comfortable driving experience.

CLS 500

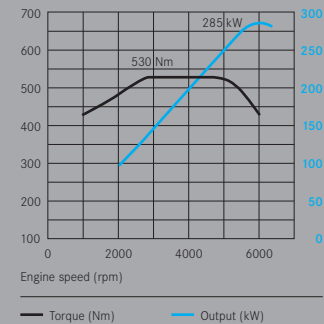

The V8 engine in the CLS 500 impresses with its smoothness and its dynamic power delivery – assets which combine to create an effortlessly superior driving experience

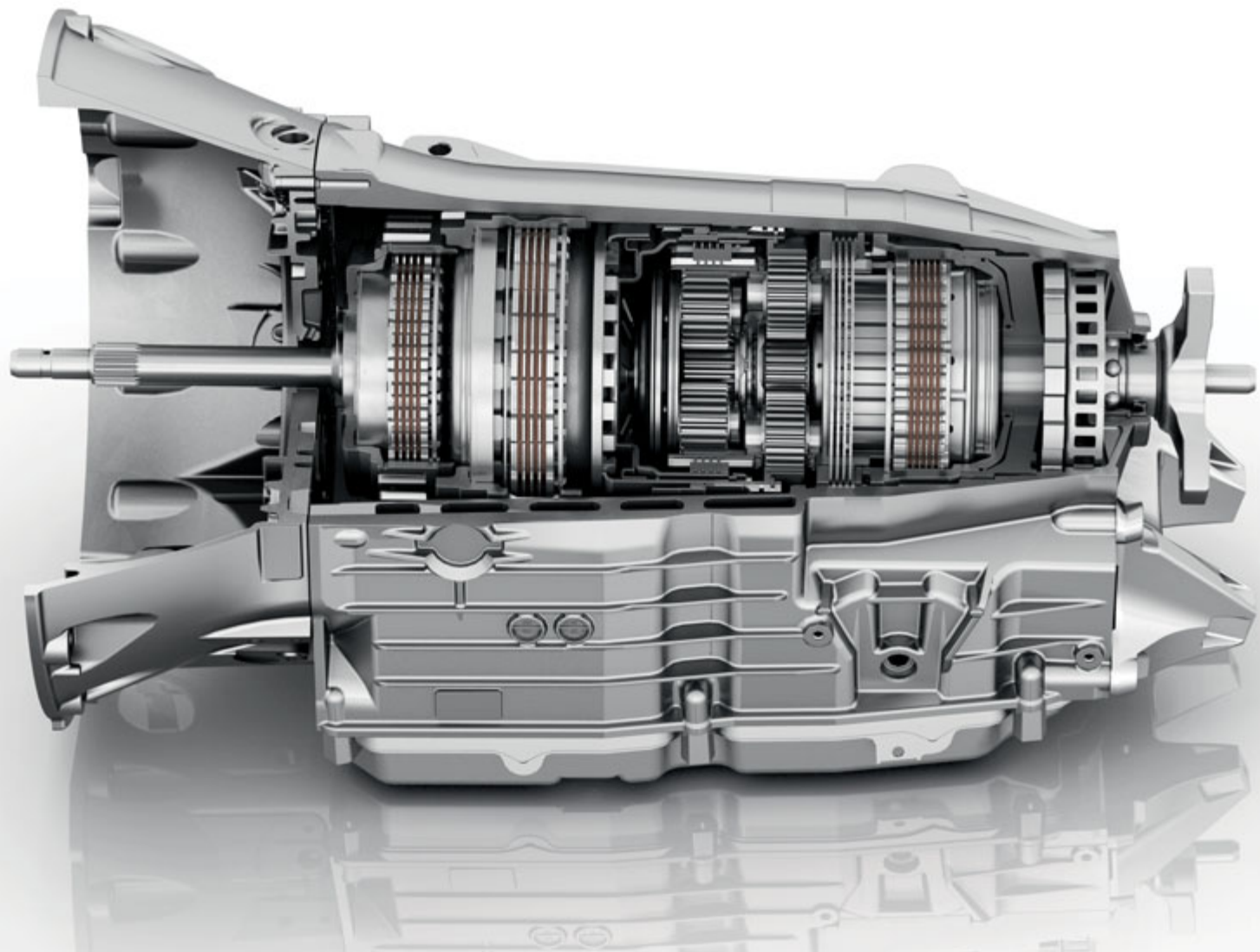

There are those who think the number seven has magical properties – our transmission developers, for example

Mercedes-Benz has always been associated with particularly refined and long-lasting automatic transmissions. Hardly surprising, perhaps, when you consider that, forty years ago, we were the first manufacturer to offer a car equipped with a hydraulic automatic transmission. Much has happened since then. And since the CLS is brimming with leading-edge technology from start to finish, all

the models are equipped as standard with the innovative 7G-TRONIC automatic transmission. Its seven forward gears allow it to react on the basis of smaller differences in engine speed, for ultra-smooth gearchanges. Optional steering-wheel shift paddles make for even faster gear changes.

Sometimes it pays to be hard. Other times a softly, softly approach is called for

Whether it be rough cobblestones or a smooth motorway, effortlessly serene progress is assured courtesy of AIRMATIC DC. This semi-active air suspension system prevents uneven road surfaces from compromising ride comfort. You can choose from three suspension modes at the touch of a button: comfort, sporty comfort or sport. To ensure that the level of the vehicle remains constant, self-levelling suspension is also included. At higher speeds, the body is automatically lowered to reduce pitch and roll movements. This system is standard for the 8-cylinder models and can be specified as an optional extra for the 6-cylinder versions.

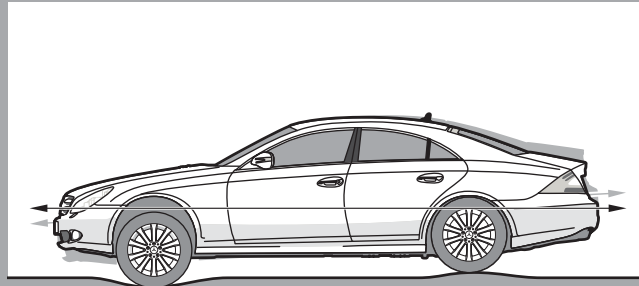

AIRMATIC DC adjusts the suspension response to your driving style, regardless of how laden the vehicle is, and thus offers even greater directional stability and road adhesion

AIRMATIC DC opens up a new dimension of comfortable and sporty driving. This is made possible by the adaptive damping system which continuously adjusts the firmness of the air suspension in accordance with the current driving situation. Instead of conventional coil springs, an electronic system adjusts the settings of the air springs by varying the air pressure to create a harder or softer set-up. Each spring strut has an additional volume of air which can be partially deactivated if necessary. If the sensors register a sporty driving style, for instance, the comfortable basic suspension automatically becomes firmer. The suspension set-up can also be adjusted manually.

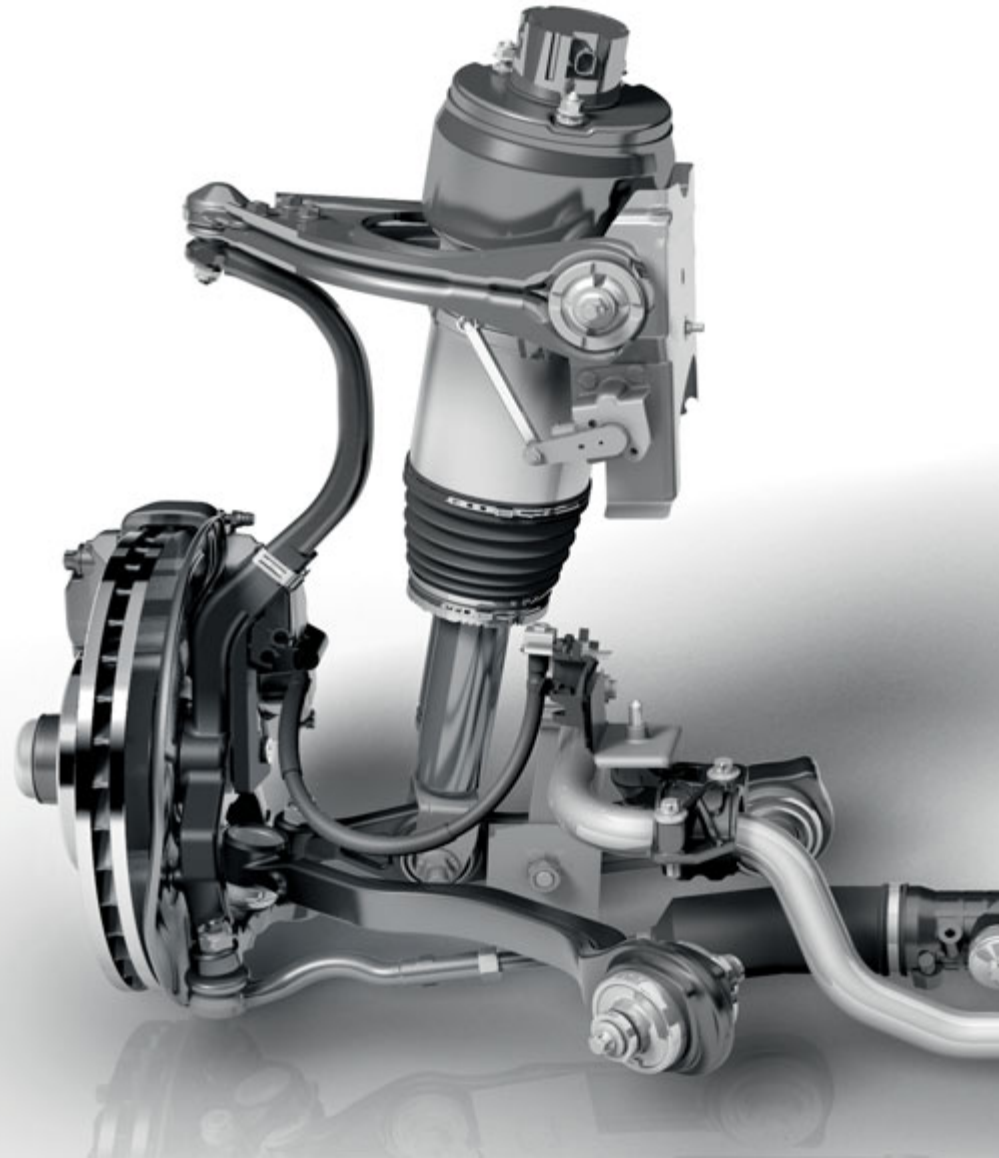

Before you set out on your journey, we set out to make it as safe as possible

Trend-setting active and passive safety technology is central to the integrated Mercedes-Benz safety concept. The CLS is equipped with numerous assistance systems whose sensors continuously monitor the driving situation, identifying hazards and triggering remedial measures where possible. Safety functions such as ESP®, ASR, ABS and BAS are, of course, standard in the CLS. In the event of a rear-end collision of a given degree of severity, the active NECK-PRO front head restraints move forwards and upwards instantly in order to support the head at an earlier stage. Depending on the type and severity of impact, the front airbags, sidebags and windowbags can be triggered selectively and inflated to differing degrees in accordance with the accident conditions. Furthermore, the CLS is equipped with the ADAPTIVE BRAKE system which includes the practical HOLD function. This holds the vehicle on a slope without requiring the driver to maintain pressure on the footbrake. It is complemented by the practical hill start assist function which prevents the vehicle from rolling backwards when setting off on a slope. In the event of emergency braking,

the adaptive brake light function warns following traffic by flashing the brake lights during the braking process and activating the hazard warning lights once the vehicle comes to a standstill.

More information about safety is available at www.mercedes-benz.com/airbag-brochure

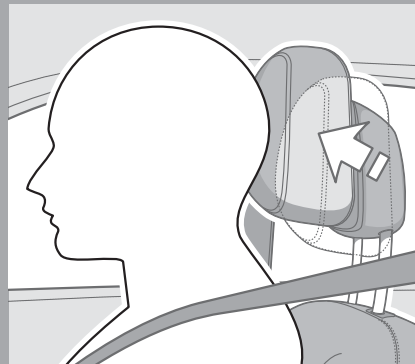

The active NECK-PRO front head restraints can help prevent whip-lash injuries

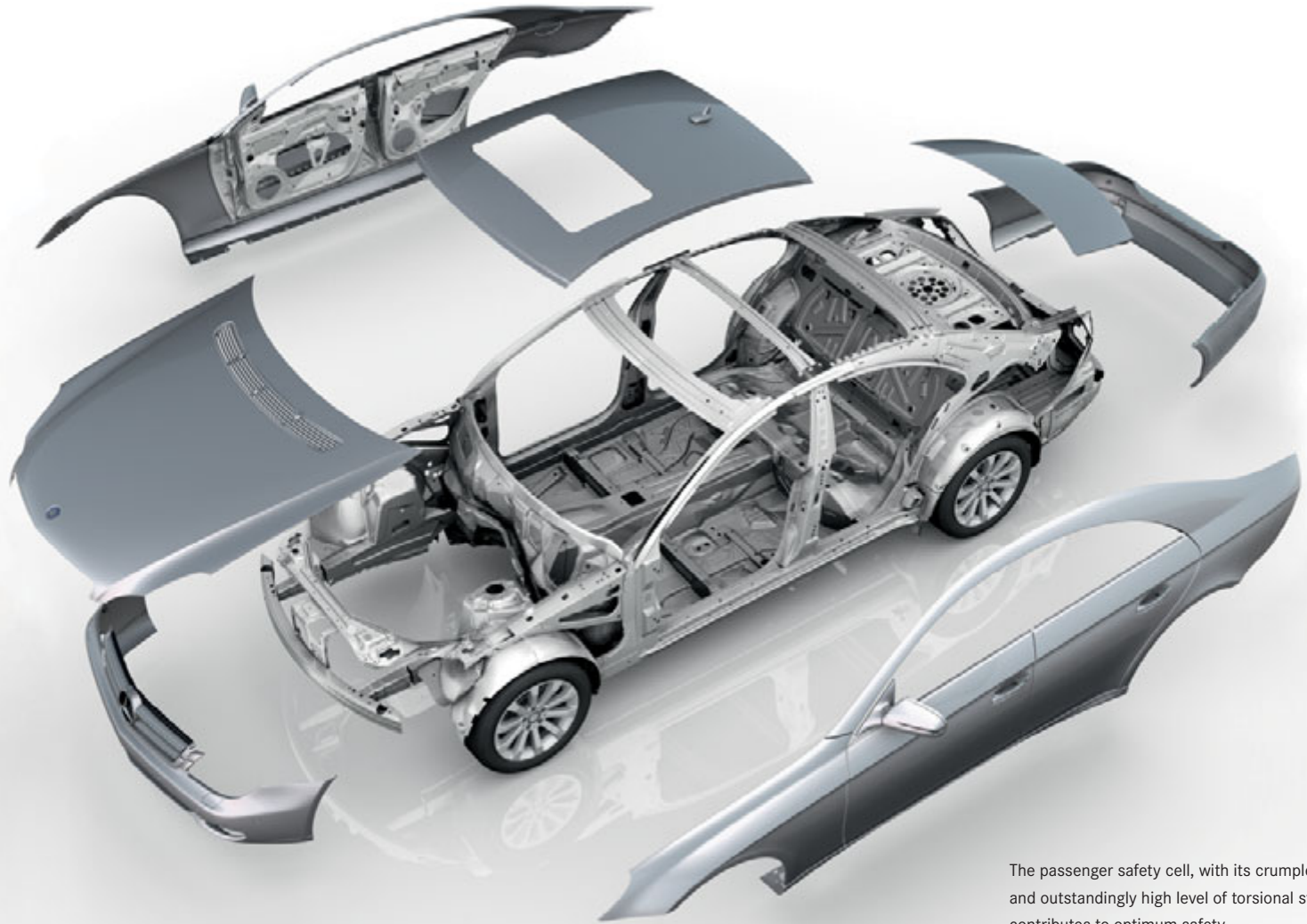

The passenger safety cell, with its crumple zones and outstandingly high level of torsional stiffness, contributes to optimum safety

Some lateral thinking by us means better visibility on bends for you

Driving on winding roads requires the utmost in concentration, especially at night. To make life much easier for you, the CLS comes with the option of bi-xenon headlamps, whose luminance is twice that of conventional halogen bulbs. The active light function (optional) allows the headlamps to follow the driver's steering movements, improving illumination on bends by up to 25%. Furthermore, the cornering light function is activated automatically as required, at speeds of up to 40 km/h, in order to boost the effect of the headlamps: when you start to turn the steering wheel, the fog lamp on the relevant side of the car is switched on in addition to the headlamps in order to ensure optimum illumination of the bend. The same thing happens when you indicate to make a turn. Bi-xenon technology also has further advantages in that the bulbs last much longer and use less energy than their conventional counterparts.

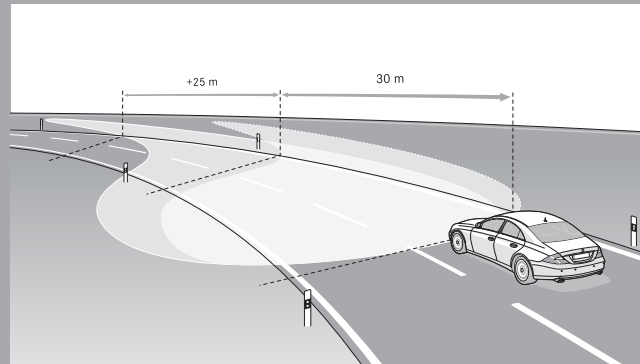

For drivers who feel that distance lends the best perspective

DISTRONIC measures the position and speed of the vehicle in front by means of a radar sensor behind the Mercedes star. These data are used to adapt the speed of your CLS (through corresponding adjustments to the engine output/application of braking force) in order to maintain a constant distance to the vehicle in front.





One of the quickest ways to upgrade from first class

You're torn between a coupé, a saloon and a thoroughbred sports car with performance to match? Then you simply need to take a decision: in favour of the CLS 63 AMG. As well as offering you a superbly dynamic driving experience, it also boasts visual highlights such as distinctive 19-inch AMG triple-spoke light-alloy wheels. What's more, the AMG V8 powerplant has a rated output of 378 kW (514 hp) and an impressive peak torque of 630 Nm. The CLS 63 AMG completes the sprint from 0 to 100 km/h in just 4.5 seconds. As well as performing like a top athlete, it also looks like one, cutting a dashing figure wherever it goes.

And thanks to its double-declutching function, the AMG SPEEDSHIFT PLUS 7G-TRONIC transmission makes for a more compelling experience and for even greater directional stability when shifting down during cornering.



High-performance sport in its most aesthetic form



The AMG sports steering wheel

A wealth of sporty highlights await you inside the CLS 63 AMG, including fine nappa leather upholstery on the exclusive AMG sports seats with Alcantara inserts. The AMG sports steering wheel with aluminium shift paddles for manual operation of the AMG SPEEDSHIFT PLUS 7G-TRONIC transmission feels as good as it looks. In this respect, it is in perfect company alongside the AMG instrument cluster including RACETIMER.



AMG sports seats upholstered in fine nappa leather with Alcantara inserts



The AMG performance steering wheel has a comfortable, sporty feel to match its looks



Designed to put the power down - 19-inch AMG twin-spoke forged light-alloy wheel



The AMG limited-slip differential enhances the driving dynamics by diverting superfluous drive torque when cornering or driving on uneven road surfaces

The *AMG PERFORMANCE STUDIO* offers you a wealth of additional options for further enhancing your CLS 63 AMG, on both a technical and a visual level. These include the AMG performance package comprising inter-

nally ventilated composite brake discs with a diameter of 390 mm at the front, an AMG limited-slip differential at the rear and forged 19-inch AMG twin-spoke light-alloy wheels all round. This package also includes the AMG

performance suspension and an AMG performance steering wheel which feels as good as it looks.

A magnet for admiring glances in its standard form, the CLS 63 AMG can be given an even sportier appearance with optional AMG carbon-fibre trim elements and illuminated AMG door sills for the interior as well as an optional AMG exterior carbon-fibre package.



Fashion moves with the times. AMG is ahead of them

The optional AMG bodystyling allows you to give any CLS model a sportier look. It comprises a distinctive front apron with large air intakes, a rear apron with a black insert, AMG tailpipes and AMG side sill panels. Attractive 19-inch AMG 5-spoke light-alloy wheels with a high-sheen finish can also be specified.





Exclusivity all the way

Whether it be a short trip or a long journey, you will always arrive feeling relaxed in the CLS. Because comfort and convenience are writ especially large in the interior. The sitting position, seat cushion height, backrest angle and seat length can all be adjusted to suit the individual requirements of the front occupants courtesy of the 4-way power seat adjustment function. As well as giving you full control over seat comfort, the CLS is equipped as standard with a 3-spoke leather-trimmed steering wheel, which feels as good as it looks. And whatever your surroundings, the view inside the cockpit is always enjoyable: the combination of the pinstripe background of the instrument cluster and the white dials creates a particularly sporty look.

“Grand Coupé” is a category that justifies comparisons with the world of the Grand Hotels. First-class appointments can be expected as a matter of course. When you take your seat, you will find that the passenger cabin offers practically everything you could wish for with regard to comfort features which reduce driver stress. Its leg, elbow and headroom are more generous than those of just about any other coupé. The wide centre console can be used as a comfortable armrest while the fine materials and high-quality workmanship throughout the extremely spacious interior create such an exclusive ambience that you could be forgiven for never wanting to get out again.

Some qualities only reveal themselves in the long run

A car designed to meet the highest customer expectations has to excel in many different areas. One of these is, of course, the way it performs on the road. But intelligent ergonomics and a high standard of comfort are scarcely less important. All four occupants of the CLS will be able to enjoy both – even on longer trips. This is because the rear passengers get a whole lot more than just their own doors. The rear compartment also boasts two comfortable individual seats that are extremely generous when it comes to elbowroom and legroom. And if you order the optional THERMOTRONIC luxury automatic climate control system, each rear passenger gets their own separately controllable temperature zone.



The THERMOTRONIC luxury automatic climate control system also allows the rear occupants to choose their own temperature settings



Ideal surroundings for those who like to be in control

Audio 50 APS offers you DVD navigation with an arrow display and junction zoom. The innovative COMAND APS multimedia system is now even more user-friendly. The functions can be entered using the ergonomically positioned input array on the centre console while many functions

can also be controlled directly from the steering wheel. And if the LINGUATRONIC voice-operated control system is fitted, the audio, telephone and navigation systems become even easier to use.



The optional AUDIO 50 APS provides you with information about the many different functions that can be controlled by the system



The optional COMAND APS has even more interactive functions which are presented on a 6.5-inch colour display

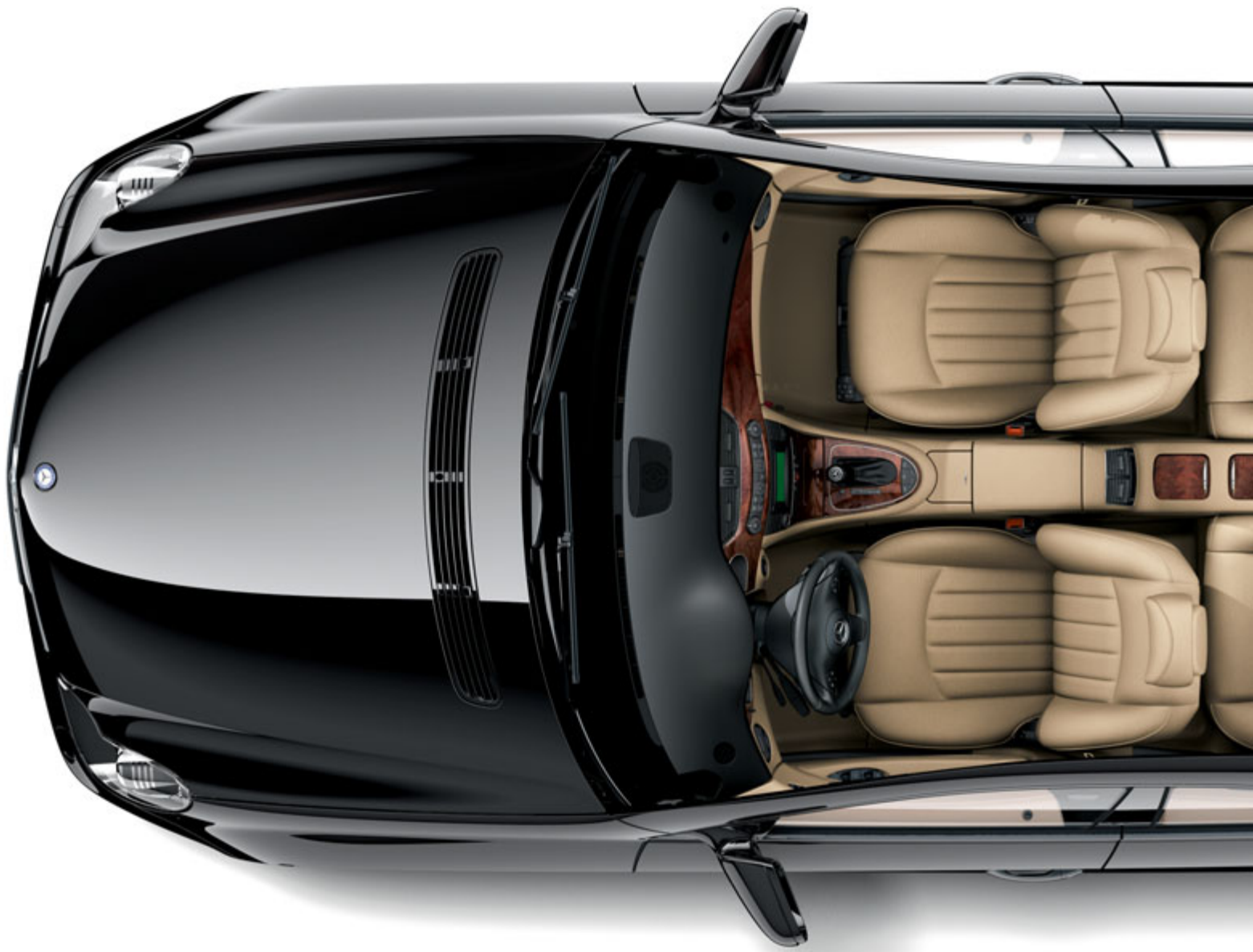

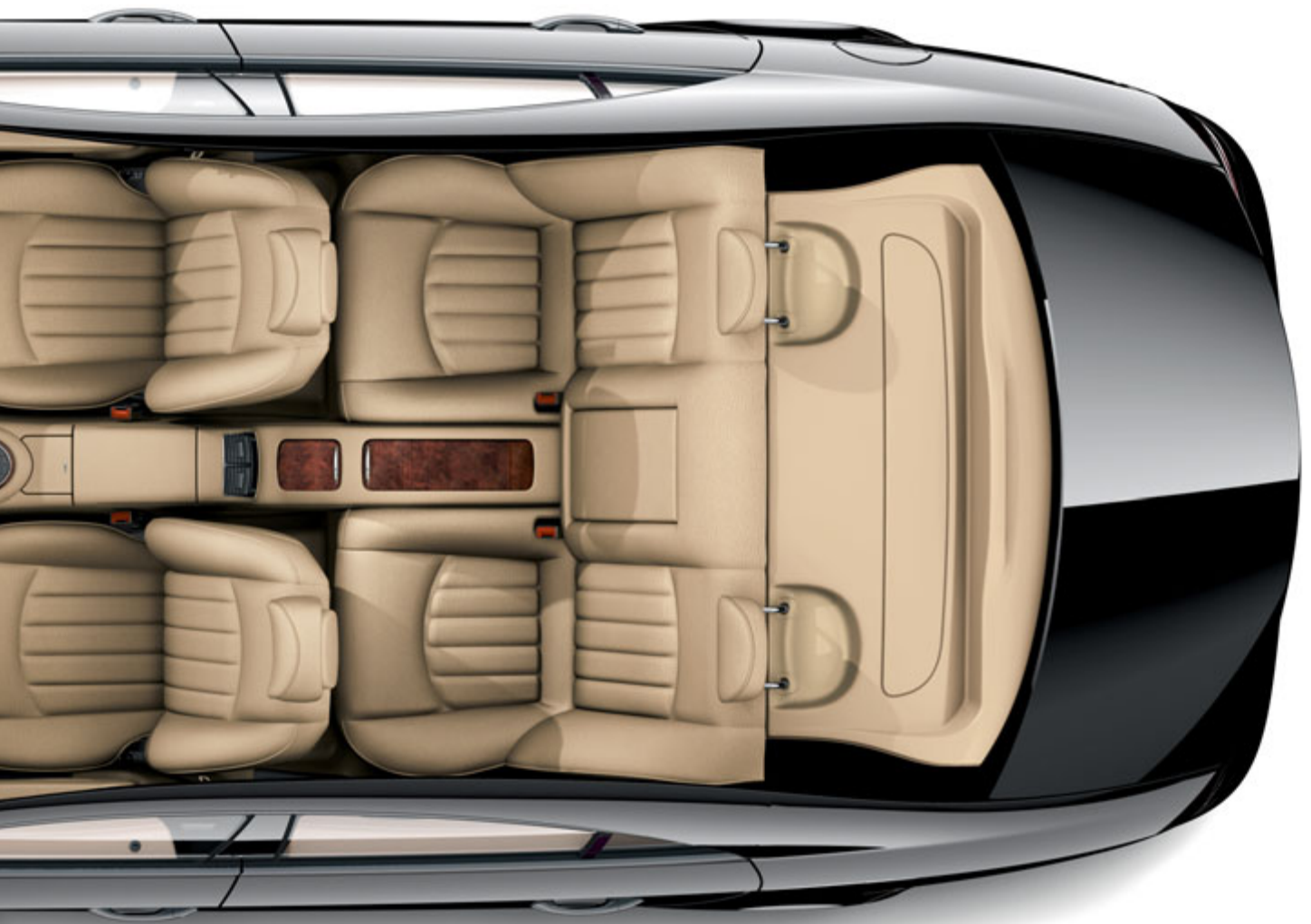

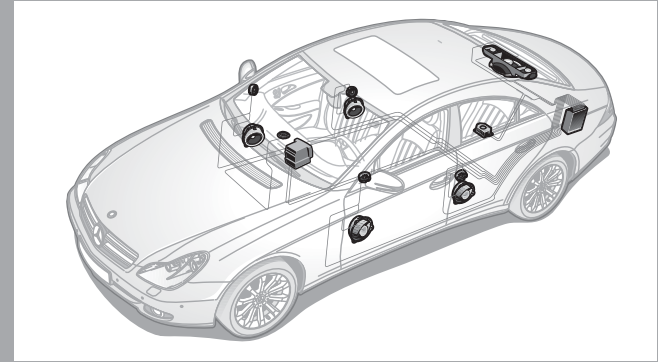

The loudspeakers of the Harman Kardon® Logic 7® surround sound system are specially matched to the interior of the CLS for optimum sound reproduction

The interior ambience of the CLS is everything you would expect of a Mercedes. In the rear, your passengers are accommodated in extremely comfortable individual seats separated by the continuation of the centre console. The latter is equipped with practical stowage compartments, while a particularly wide centre armrest can be folded down for even greater seating comfort. Outstanding workmanship and high-quality, exclusive materials also con-

tribute to the unique atmosphere which Mercedes-Benz has made synonymous with refined automotive comfort. And to make sure that all the occupants can enjoy an ideal listening experience, the CLS is equipped as standard with nine loudspeakers. This system can be extended to as many as twelve speakers with the optional Harman Kardon® Logic 7® or AMG high-end surround sound system.

It's already a thing of beauty. And now you can make it unique

No two people are alike. That is why we offer the comprehensive designo appointments range which allows you to design your CLS entirely in accordance with your own ideas and wishes. You can choose from a wide range of attractive metallic paint finishes, fine leather hues and high-quality trim elements.







Exclusive designo appointments make it possible to fulfil just about any vision you may have for your CLS. You can choose to have the seats and door centre panels finished in fine designo leather (shown here in designo porcelain, X27) or – for an even more exclusive touch – in designo Exclusive leather. CLS models equipped with designo Exclusive



With designo Exclusive leather, the door centre panels are finished in the finest designo leather with attractive double topstitching

leather can be identified by the distinctive double topstitching in the door centre panels. Trim elements made with hand-selected woods or gleaming jet black piano lacquer create an exclusive, individualised ambience. The roof liner, available as an option in fine anthracite-colour Alcantara, rounds out this offer.



Available as an option: fine trim elements in designo black piano lacquer

My CLS





Luxury comes as standard in the CLS. But you can still take things a step further

The CLS is by definition an extremely comfortable vehicle. But you can still choose from a large number of optional functions and equipment items to make it even more comfortable and individual. Even in standard form, it comes with the Audio 20 CD radio system, a multifunction steering wheel and cruise control with the SPEEDTRONIC variable speed limiter. Other items of standard equipment are shown in the table opposite.



The multifunction steering wheel allows the driver to use the telephone and the radio as well as to select various vehicle functions which are shown on the instrument cluster display while keeping both hands on the wheel



Fitted as standard in the 6-cylinder models, the THERMATIC air-conditioning system with combination filter and air recirculation switch ensures pleasant temperatures all year round in your CLS



The THERMOTRONIC luxury automatic climate control system offers extra functionality by allowing each of the four occupants to control the temperature in their own zone

Standard equipment (selection)

3-point seat belts, adjustable in the front, with automatic height adjustment in the rear
3-spoke multifunction steering wheel
7G-TRONIC 7-speed automatic transmission
ADAPTIVE BRAKE system with HOLD function
Airbags with multi-stage deployment logic and sidebags for driver and front passenger, plus windowbags
AMG SPEEDSHIFT PLUS 7G-TRONIC in the CLS 63 AMG
ASSYST PLUS service interval indicator and service computer
Audio 20 CD radio with telephone keypad, 9 loudspeakers, rear-windscreen radio aerial
Brake Assist BAS
Cruise control and SPEEDTRONIC variable speed limiter with brake intervention
Electrically adjustable front seats

Electronic Stability Program ESP®
Head restraints (4): electrically folding in rear, NECK-PRO crash-responsive versions in the front
Heated exterior mirrors, electrically adjustable, aspherical, with integral indicators
Integrated safety concept
Particulate filter for CLS 320 CDI
Power windows (4) with one-touch control and obstruction sensor
Speed-sensitive power steering with safety steering column
THERMATIC automatic climate control in the CLS 320 CDI, CLS 280 and CLS 350 CGI
THERMOTRONIC 4-zone automatic climate control in the CLS 500 and CLS 63 AMG
Tinted glass all round, rear window in single-layer safety glass
Windscreen wipers with one-touch function, rain sensor and infinitely variable intermittent setting

KEYLESS-GO allows you to unlock the CLS without touching the vehicle with the key and also to start and stop the engine by means of a button on the selector lever. You can also specify particularly comfortable dynamic multicontour front seats along with the memory package. These are just two examples of how you can make using the CLS even more comfortable and convenient. Another option is the radar-based DISTRONIC proximity control system which automatically maintains a constant distance to the vehicle in front in order to reduce driver stress.



The optional wood/leather steering wheel adds a particularly exclusive touch to the interior



Shift paddles on the steering wheel put sporty gearchanges at the driver's fingertips



The start/stop button for the optional KEYLESS-GO system is located on the selector lever knob



The optional multicontour seats can be individually adjusted to match the body's contours for even greater comfort

How about some crystal-clear competition for the sound of the engine?

The CLS is equipped as standard with the Audio 20 CD radio and nine loudspeakers while the Audio 50 APS system is available as an optional extra. For the ultimate in ease of operation, you can also opt for the innovative COMAND APS multimedia system, which combines numerous functions. COMAND APS makes it even easier to control the radio, DVD player, navigation system and telephone. For the utmost in listening pleasure, we recommend the optional Harman Kardon® Logic 7® surround sound system with twelve metal-matrix loudspeakers and an output of 510 watts or the AMG high-end surround sound system with two ICEpower digital amplifiers and an output of 705 watts.



When combined with the Audio 50 APS radio, including CD drive, RDS tuner and telephone keypad, the Harman Kardon® Logic 7® surround sound system delivers exclusive stereophonic sound as an optional extra



The AMG high-end surround sound system offers a listening experience of the very highest calibre



The electric tilting/sliding glass sunroof can be opened to admit fresh air at the touch of a button



The optional PARKTRONIC parking aid indicates the distance to obstacles



The optional memory package stores the position of the front seats, the steering column and the exterior mirrors

Optional extras (selection)

Anti-theft alarm with tow-away protection and interior monitoring

Audio 50 APS radio with DVD navigation system

Bi-xenon headlamps with active light function/cornering light function¹ in the fog lamps

Climatised front seats (with seat ventilation and heating), incl. luxury head restraints

COMAND APS multimedia system for radio/navigation

DISTRONIC proximity control

Dynamic multicontour seats for driver and front passenger

Electric tilting/sliding glass sunroof

Harman Kardon® Logic 7® surround sound system with 12 high-performance loudspeakers

Headlamp cleaning system

KEYLESS-GO

Memory package for front seats, steering column and exterior mirrors

Multifunction steering wheel with shift paddles

PARKTRONIC

Pre-installation for mobile phone in the centre-console armrest, including hands-free system and aerial

Semi-active air suspension (AIRMATIC Dual Control) for the CLS 320 CDI, CLS 280 and CLS 350 CGI

THERMOTRONIC 4-zone automatic climate control for the CLS 320 CDI, CLS 280 and CLS 350 CGI

Wood/leather multifunction steering wheel (leather version can also be heated as an option)

¹ Cornering light function not available for the CLS 63 AMG

Light-alloy wheels



17-inch 10-spoke light-alloy wheels (standard for CLS 320 CDI, CLS 280 and CLS 350 CGI)



18-inch 5-spoke light-alloy wheels (standard for CLS 500, optional for 6-cylinder models)



18-inch 5-twin-spoke light-alloy wheels with high-shine finish and mixed-size tyres (optional extra)



19-inch AMG 5-spoke light-alloy wheels with high-shine finish and mixed-size tyres (optional extra)



18-inch 8-spoke light-alloy wheels with mixed-size tyres (genuine accessories)



18-inch 7-spoke light-alloy wheels with mixed-sized tyres (genuine accessories)

Accessories

Whether you need to carry winter sports equipment or you just want to increase the stowage space, Mercedes-Benz genuine accessories are always the best choice because they are developed and tested in close cooperation with our engineers.



Attractive door sill panels make a clear statement of individuality



The chromed metal and plastic coat hanger fits simply onto the front head restraints to protect your jacket from creasing during the journey



The non-slip flat boot tub is easy to clean and helps to protect the boot of your CLS

The irresistible beauty of a beautifully resistant finish

The CLS paintwork puts the finishing touch to the carefully crafted Mercedes-Benz corrosion protection system, which includes zinc phosphating and electrophoretic dip-priming stages to ensure long-lasting protection. We also make very extensive use of eco-friendly water-based paints.

NON-METALLIC PAINTS

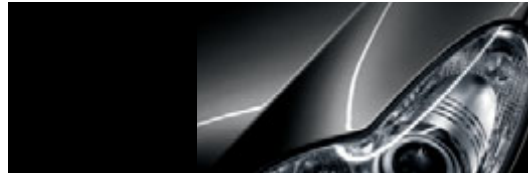

040 black

METALLIC PAINTS



197 obsidian black



300 periclase green



359 tanzanite blue



368 flint grey



723 cubanite silver



799 diamond white BRIGHT



492 rutile brown



775 iridium silver



963 indium grey



544 carneol red



798 sanidine beige

“Biarritz” FABRIC/LEATHER

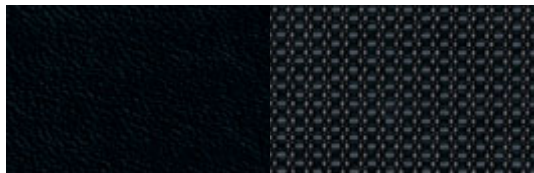

001 black

LEATHER optional extra¹

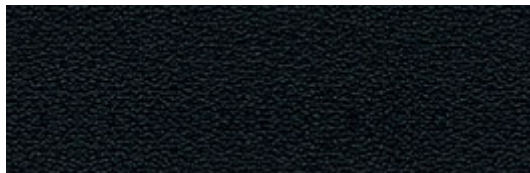

201 black



208 basalt grey

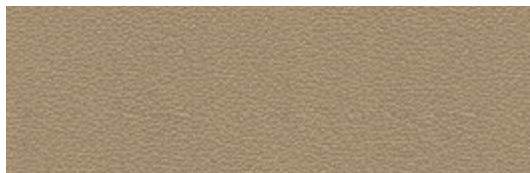

204 cashmere beige



207 sunset red

¹ Standard in the CLS 500

NAPPA LEATHER, Club-design optional extra /
NAPPA LEATHER, Exclusive Club-design optional extra



861/811 black

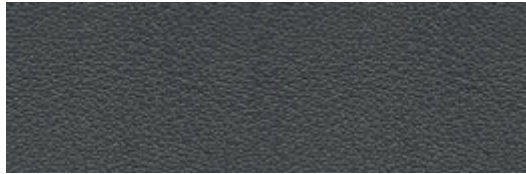

868/818 basalt grey

NAPPA LEATHER standard for CLS 63 AMG /
EXCLUSIVE NAPPA LEATHER optional extra for CLS 63 AMG



281/581 black

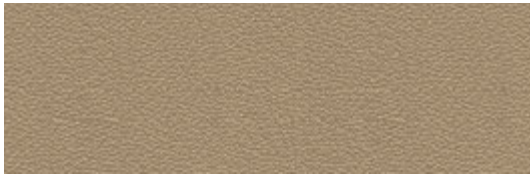

864/814 cashmere beige



284/584 cashmere beige



867/817 sunset red



288/588 basalt grey

TRIM ELEMENTS

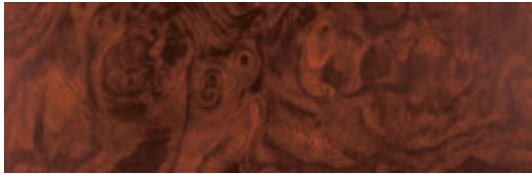

Silk matt burr walnut

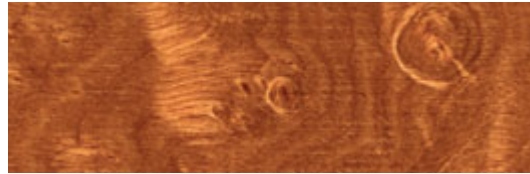
Chestnut¹Black bird's-eye maple¹High-gloss laurel¹¹Optional extra



designo

designo

designo LEATHER



X06 marron



X13 mystic red



X17 classic red



X07 armagnac



X14 graphite green



X27 porcelain



X10 sand



X16 mauritius blue



X32 chablis

For details of designo paints, please see our designo brochure

designo TRIM ELEMENTS

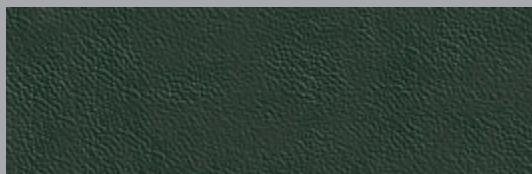

X49 corteccia



W21 natural matt oak grain

designo ALCANTARA ROOF LINER

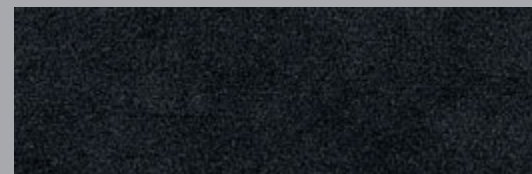

Y83 anthracite

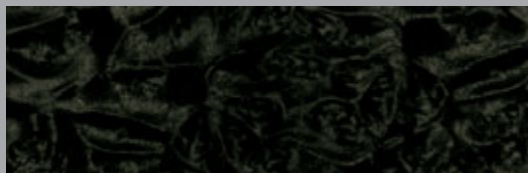

W66 umber maple grain

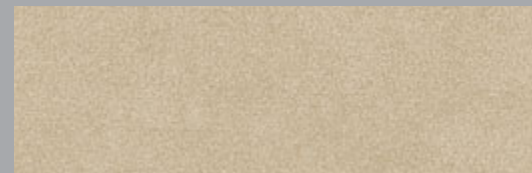

Y84 pebble beige

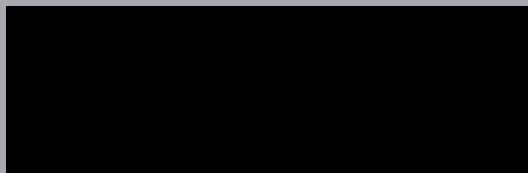

W69 black piano lacquer

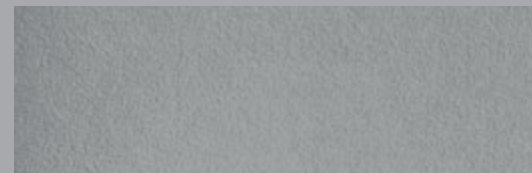

Y85 alpaca grey

Paintwork and upholstery – the combination options

	"Biarritz" FABRIC/LEATHER	LEATHER ¹				NAPPA LEATHER				
		black	black	cashmere beige	sunset red	basalt grey	black	cashmere beige	sunset red	basalt grey
NON-METALLIC PAINTS										
black	<input type="checkbox"/>	●	●	●	●	●	●	●	●	●
METALLIC PAINTS										
obsidian black	<input type="checkbox"/>	●	●	●	●	●	●	●	●	●
periclase green	<input type="checkbox"/>	●	●	△	○	●	●	△	○	
tanzanite blue	<input type="checkbox"/>	●	○	△	●	●	○	△	●	
flint grey	<input type="checkbox"/>	●	○	○	○	●	○	○	○	
rutile brown	<input type="checkbox"/>	●	●	○	○	●	●	○	○	
carneol red	<input type="checkbox"/>	●	●	△	○	●	●	○	○	
cubanite silver	<input type="checkbox"/>	●	△	●	△	●	△	●	△	
iridium silver	<input type="checkbox"/>	●	○	●	●	●	○	●	●	
sanidine beige	<input type="checkbox"/>	●	●	△	△	●	●	△	△	
diamond white BRIGHT	<input type="checkbox"/>	●	○	●	●	●	○	●	●	
indium grey	<input type="checkbox"/>	●	●	△	△	●	●	△	△	

□ Standard

● Recommended

○ Possible

△ Not recommended

¹ Standard in the CLS 500

Technical data

	CLS 320 CDI	CLS 280	CLS 350 CGI	CLS 500	CLS 63 AMG
No. of cylinders/arrangement	6 / V	6 / V	6 / V	8 / V	8 / V
Total displacement (cc)	2987	2996	3498	5461	6208
Rated output ¹ (kW at rpm)	165 / 3800	170 / 6000	215 / 6400	285 / 6000	378 / 6800
Rated torque ¹ (Nm at rpm)	540 / 1600–2400	300 / 2500–5000	365 / 3000–5100	530 / 2800–4800	630 / 5200
Compression ratio	17.7	11.3	12.2	10.7	11.3
Acceleration 0–100 km/h (s)	7.0	7.7 ²	6.7 ²	5.4 ²	4.5
Top speed, approx. (km/h)	246	245	250 ³	250 ³	250 ³
Tyre size	245 / 45 R 17	245 / 45 R 17	245 / 45 R 17	245 / 40 R 18	255 / 35 R 19 (front) 285 / 30 R 19 (rear)
Fuel	Diesel	Premium	Premium	Premium	Super Plus
Fuel consumption ⁴ (l / 100 km) urban/extra-urban/combined	10.6–11.0/5.9–6.4/7.6–8.1	13.8–14.1/7.4–7.7/9.8–10.0	13.0–13.2/7.0–7.2/9.1–9.3	17.0–17.2/8.5–8.7/11.6–11.8	22.6/9.9/14.5
CO ₂ emissions ⁴ (g/km) combined	200–215	233–237	217–222	275–280	345
Tank capacity (l), of which reserve approx.	80 / 9	80 / 9	80 / 9	80 / 9	80 / 14
Turning circle (m)	11.2	11.2	11.2	11.2	11.5
Kerb weight ⁵ (kg)	1815	1730	1735	1835	1905
Permissible GVW (kg)	2280	2195	2200	2300	2370

¹ Figures according to Directive 80 / 1269 / EEC in the currently applicable version

² On models with the optional multifunction steering wheel with shift paddles, the 0–100 km/h acceleration time is 0.2 seconds faster in manual shift mode

³ Electronically governed

⁴ The figures shown were obtained in accordance with the prescribed measuring process (Directive 80 / 1268 / EEC in the currently applicable version).

The figures are not based on an individual model and do not constitute part of the product offer; they are provided solely for purposes of comparison between different vehicle models

⁵ Figures according to Directive 92 / 21 / EC, version 95 / 48 / EC (kerb weight with fuel tank 90 % full, driver, 68 kg, and luggage, 7 kg) for standard-specification vehicles.

Optional extras and accessories will generally increase this figure and reduce the payload capacity accordingly

The dimensions of the CLS-Class

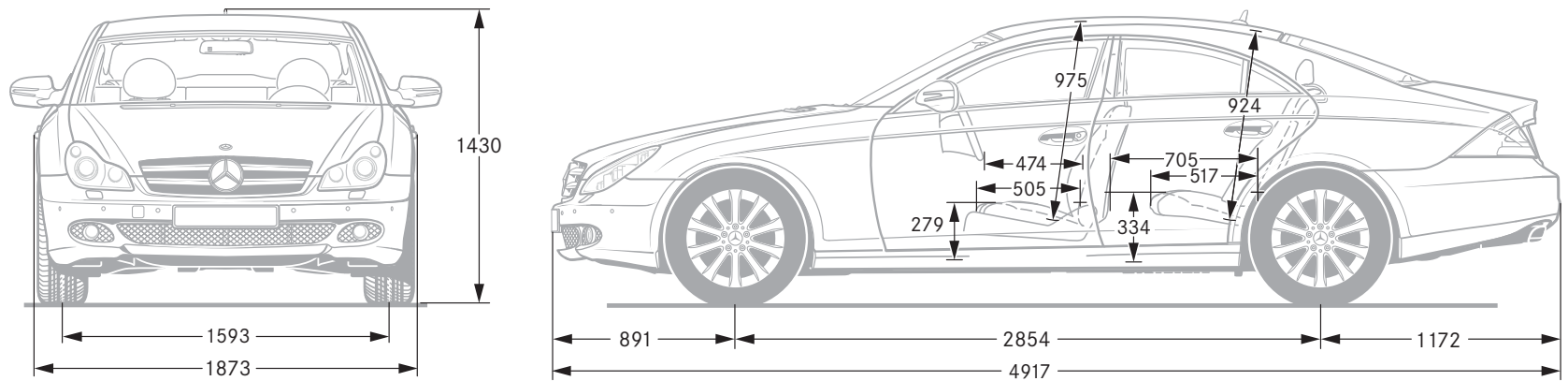

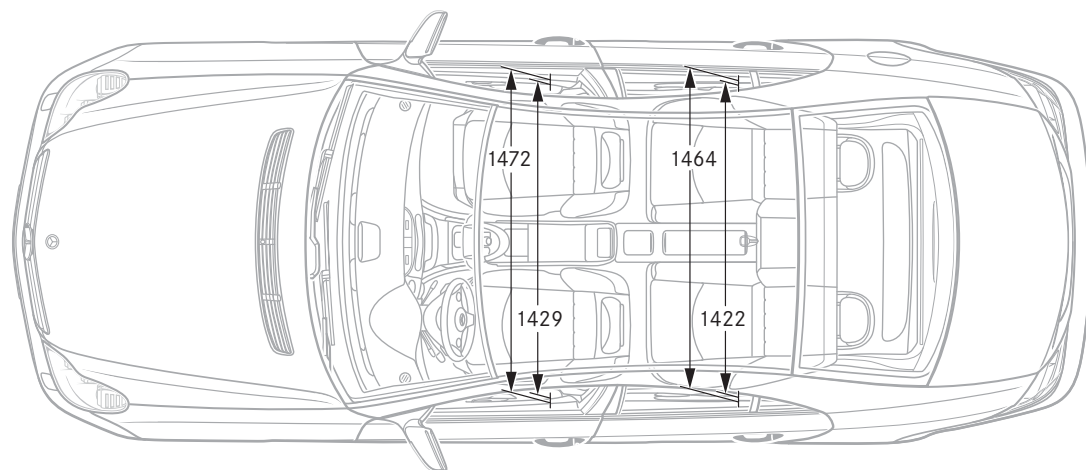
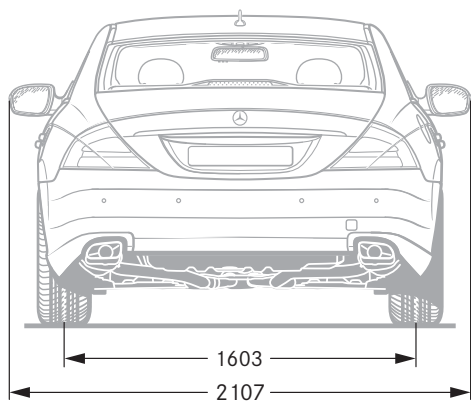



Anyone opting for a Mercedes buys far more than just a car

Comprehensive service offered by Mercedes-Benz

Mercedes-Benz Service24h

The feel-good factor, which kicks in when you sit behind the wheel of your new Mercedes for the first time, is further enhanced by the knowledge that Mercedes-Benz Service24h is there for you around the clock – 365 days a year. Experience shows that your Mercedes model is extremely unlikely to suffer a technical problem or breakdown. And even if the unthinkable happens, you can always count on Mercedes-Benz Service24h, wherever you are in Europe. Just call our Service Hotline on 00800 1 777 7777¹ at any time. One of our specialists will take your call and arrange professional assistance for you immediately. By the time you put down the phone, our Service24h team will be getting ready to make their way to you. It will often be possible to sort out the problem at the scene. If this is not the case, however, we will of course arrange for your car to be taken to the nearest Mercedes-Benz workshop.

MercedesCard

Your ticket to the Mercedes-Benz experience: the quarterly MercedesCard ARGENTUM journal offers you an exclusive selection of exciting events starring the Mercedes-Benz brand. In addition, the Mercedes magazine is packed with gripping and inspiring articles and reports. The MercedesCard has many other functions: as a VISA credit card, it is an accepted form of payment worldwide – with no annual fee if you complete a questionnaire every year. In addition, it offers further benefits to put your mind at ease, such as the Mercedes-Benz insurance package, at no extra charge, and the exclusively compiled MercedesCard insurance package at a preferential rate. For further information about this offer, available exclusively to Mercedes-Benz drivers, visit www.mercedes-benz.de/mercedescard²

Mercedes-Benz Bank

If you have already chosen your dream car and want to remain financially flexible, the Mercedes-Benz Bank should be your next port of call. We are your one-stop shop for leasing, financing, insurance and service packages. By way of example, our “Private Leasing plus” scheme is a complete package comprising leasing, insurance and a purchase option, while our “Plus3” finance package combines low rates with high flexibility. That’s because, at the end of the contract, you decide yourself whether to keep your car, sell it or return it to us for a guaranteed price. We also offer an attractive range of investment products, including instant-access savings accounts, fixed-interest products and investment funds. For further information, please call us on 01803/32 22 65³ or visit us at: www.mercedes-benz-bank.de

¹ Freephone number, mobile-phone rates may vary

² Information about the MercedesCard in Austria and Switzerland can be found on the Mercedes-Benz websites for these countries

³ 9 ct/min from Deutsche Telekom landlines, mobile-phone rates may vary



Time for another enriching experience

A Mercedes-Benz is most at home on the road. This is the only way to experience the effortlessly superior driving feel that lends every model its inimitable class. Feel the power of the engine as it propels the car forwards. Marvel at the precise steering, designed to really put you in the mood for driving. And experience what true comfort really feels like. The unique feeling of driving a Mercedes cannot be put into words, however. Which is why we'd like to invite you to take a test drive. Your Mercedes-Benz dealer will be happy to make all the necessary arrangements for you. Simply visit www.mercedes-benz.com to locate the nearest Mercedes-Benz dealer in your country or region. We look forward to seeing you.

The website also offers an interactive tour, enabling you to take a closer look at your desired model. This simulation is the ideal way to acquaint yourself with your dream car. You can view key functions in detail, gain an insight into the car's inner workings or look at the benefits of each model. For further details, visit www.mercedes-benz.de/owners-manual

Now your mobile phone acts as a gateway to the whole Mercedes-Benz world. In addition to an overview of all passenger car models, there are insights into the entire brand world, not to mention a wealth of entertainment offers and direct links to a range of services at www.mercedes.mobi

Take-back of end-of-life vehicles. Coming full circle. At the end of its long life, you can return your CLS to us for environment-friendly disposal in accordance with the EC End-Of-Life Vehicle Directive¹. But that day lies a long way off.

¹ Applies in accordance with national regulations to vehicles up to 3.5 tonnes gross weight. Mercedes-Benz passenger cars have met the statutory regulations governing the suitability of their design for reuse and recycling for a number of years now. A network of vehicle take-back depots and dismantlers has been established which will process your vehicle in an environment-friendly manner. The ways in which both vehicles and parts can be recovered are subject to ongoing development and improvement. Consequently, the CLS will be able to comply with any future increases in the recycling quota within the stipulated time limits. For further information, go to www.mercedes-benz.de or call 00800 1 777 7777

Please note: changes may have been made to the product since this brochure went to press (15.08.2008). The manufacturer reserves the right to make changes to the design, form, colour and specification during the delivery period, provided these changes, while taking into account the interests of the vendor, can be deemed reasonable with respect to the purchaser. Where the vendor or the manufacturer uses symbols or numbers to describe an order or the subject of an order, no rights may be derived solely from these. The illustrations may show accessories and items of optional equipment which are not part of standard specification. Colours may differ slightly from those shown in the brochure, owing to the limitations of the printing process. This brochure has been compiled by Daimler AG of Germany and is distributed internationally. It provides a general indication of the range of models, features, optional extras and/or colours available in various countries. Some of the models, features, optional extras and/or colours may not be available in your country, or may only be available in a different specification. Additionally some models, features, optional extras and/or colours may only be available in combination with others. For current and more specific information in relation to the range of models, features, optional extras and/or colours available in your country, and their pricing, you should contact your nearest authorised Mercedes-Benz Passenger Car Dealer. www.mercedes-benz.com