



This Brochure is prepared by Daimler AG and it predominantly reflects the capabilities and performance of vehicles sold in Europe. Some characteristics, capabilities, performance features and optional extras (e.g. towing systems) may not be available or may not apply in Australia or under Australian conditions. The information in this Brochure is therefore indicative, illustrative and provided only for guidance and should not be relied on. To obtain current and accurate information on a vehicle and any options applicable to Australia, contact your local authorised Mercedes-Benz dealer.

Mercedes-Benz



Mercedes-Benz

The new-generation **SL-Class**

From the Mercedes-Benz dream factory

# Contents

<b>The SL</b>	<b>6</b>	<b>My SL</b>	<b>68</b>
<b>Agility</b>	<b>14</b>	<b>Equipment</b>	<b>70</b>
TrueBlueSolutions	14	Sports package	70
Engines	16	Standard equipment	74
Transmissions	26	Light-alloy wheels	76
Suspension	28	Seats	80
Direct-Steer system	30	Optional extras	82
AIRSCARF	32	Genuine accessories	84
		designo	86
<b>Comfort</b>	<b>34</b>	<b>Colours and materials</b>	<b>92</b>
Vario-roof	34	Paintwork	92
Interior	36	Upholstery and leather	94
Seating comfort	40	Trim elements, wood and designo	96
SL 600	42	Combination options	97
COMAND	44		
Surround sound system	46	<b>Technical data</b>	<b>98</b>
<b>Safety</b>	<b>48</b>	<b>Service</b>	<b>100</b>
<b>AMG</b>	<b>54</b>	<b>Test drive</b>	<b>102</b>

# About as close to heaven on earth as it gets

How do you continue what is already a staggering success story? Simple. By making things even better. This is also very much the philosophy behind the SL. With more powerful, more economical engines. With state-of-the-art Mercedes-Benz technology. With new design elements such as side gills painted in either silver (SL 600) or the vehicle colour (all other models). And with an even sportier front section and rear end. Plus a choice of exclusive paint finishes and, to round it all off, a selection of new, attractive wheels. One thing is apparent right away: the new generation first celebrates and then builds upon the great achievements of the past.

## Two letters are enough to write a legend: SL



It takes three days to cover the 1600 kilometres from Brescia in Lombardy to Rome and back, on roads which run through sleepy villages and across impressive piazzas. This is, of course, the route of the world's most famous road race of all. We're taking the SL back to the route on which its distinguished ancestor, another series-production roadster, made history back in 1955. Raced by the Fitch/Gesell Team, the 300 SL of more than half a century ago left all the favourite Italian models in the GT class above 1.6 litres trailing in



its wake. And now we're revisiting this culturally rich route in a roadster which sets new standards for refined driving and whose engine and chassis provide ample evidence that they are worthy of the legendary SL name. The design, appointments and sound of the roadster are as impressive to outside observers as they are to the driver. Now you can write the next chapter of the 300 SL Gullwing legend yourself. Such rare pieces of Mercedes-Benz history can still be acquired by visiting [www.mercedes-benz.de/classic](http://www.mercedes-benz.de/classic)









The SL





A sports car has to get under your skin to find its way to your heart



When you're leading the way, it's nice  
to know you look good from behind



SL 600



D S SL 6001





Adrenalin - the only fuel you take on board whilst on the move



# TrueBlueSolutions

Climate change is one of the major challenges of the 21<sup>st</sup> century. The rising consumption of natural resources is having an increasing impact on our planet. As the inventor of the motor car, Mercedes-Benz has a special responsibility to implement innovative technologies in order to develop solutions that help preserve the environment and ensure that raw materials are used as efficiently as possible – without compromising on comfort, safety and driving enjoyment. We call them TrueBlueSolutions.

Our goal is emission-free mobility. To achieve this goal, we have developed a number of concepts, one of which is **BlueEFFICIENCY**. This custom-designed package of efficiency measures can reduce fuel consumption by up to 12 %: various aerodynamic and energy-management measures are implemented individually for each model to maximise savings in each case. These include tyres with low rolling resistance, lightweight materials, changes to the body aerodynamics and the automatic ECO start/stop function. As for

diesel engines, Mercedes-Benz has brought to market its **BlueTEC** technology based on common-rail direct injection (CDI). This technology is the embodiment of the world's cleanest diesel as it can reduce nitrogen oxides by up to 80 %. Great things are also expected of **BlueHYBRID** technology - a combination of a highly efficient internal combustion engine and an electric motor. Vehicles equipped with this drive system raise the bar once again in terms of economy and cleanliness, as will be shown by the S-Class from 2009 onwards. Mercedes-Benz calls the equivalent technology for diesel vehicles **BlueTEC HYBRID**. A prototype



**BlueTEC.** The world's cleanest diesel technology in a modern-day vehicle. The E-Class is also available with BlueTEC technology

version of this system can be seen in the Vision GLK 300 BlueTEC HYBRID<sup>1</sup>, which is currently the world's cleanest and most economical SUV. It returns a combined consumption figure of just 5.9 l/100 km. And with the F700 research vehicle, we have succeeded in combining the advantages of a petrol engine with those of a diesel powerplant. The **DIESOTTO** drive at the heart of the F700 may have petrol in the tank; however, it operates like an economical diesel model in many driving situations. Mercedes-Benz also sees great potential in the development of the fuel cell. This highly promising drive system requires no



**BlueEFFICIENCY.** Numerous models, various measures, one goal: maximum efficiency



mineral fuel whatsoever and operates with zero emissions. The first of these vehicles to be built under series-production conditions – the B-Class F-CELL – is due in 2010.

However, our extensive TrueBlueSolutions concept does not just include new drive technologies. Under the banner **Design for Environment**, we look at the vehicle's entire lifecycle – from planning to recycling. The same applies to the building and running of new plants. We save energy, avoid pollutants and increase the use of renewable raw materials. Incidentally, Mercedes-Benz is the



**BlueHYBRID.** Looking forward to one of the world's most economical luxury saloons. The S-Class from 2009

world's only car brand to have received the independently awarded TÜV<sup>2</sup> environmental certificate. TrueBlueSolutions also involves the active participation of the Group and its employees in environmental protection measures both inside and outside the company's plants. And it incorporates a commitment to developing second-generation alternative fuels (BTL/Biomass-to-Liquid fuels), such as SunDiesel<sup>®</sup>, which are not at odds with food production. Another aspect of TrueBlueSolutions is the research discipline of bionics, which looks at structures and designs in the natural world in order to optimise the



**BlueTEC HYBRID.** The Vision GLK 300 BlueTEC HYBRID<sup>1</sup> is the most efficient combination of BlueTEC diesel and hybrid modules

weight and aerodynamics of body constructions, for example. Last but not least, you can also do your bit for TrueBlueSolutions by adapting your driving style.

For further information on our extensive package of measures, go to [www.mercedes-benz.com/truebluesolutions](http://www.mercedes-benz.com/truebluesolutions)

<sup>1</sup> Provisional figures: combined fuel consumption: 5.9 l/100 km; overall CO<sub>2</sub> emissions: 157 g/km

The figures are not based on an individual vehicle and do not constitute part of the product offer; they are provided solely for purposes of comparison between different vehicle models

<sup>2</sup> TÜV SÜD Management Service GmbH, Munich



**F-CELL.** Emission-free mobility with the drive system of the future: the B-Class F-CELL goes into production in 2010

## Prepare to power through

The only thing you may have difficulty doing with your SL 350 is leaving it alone. The mere act of starting the six-cylinder engine developing 232 kW (316 hp) and a peak torque of 360 Nm sets your pulse racing immediately. Acceleration on the road is equally impressive: from 0 to 100 km/h in just 6.2 seconds.

The sports engine draws its enormous power reserves from the depths of its 3498-cc displacement thanks to a higher

compression ratio and the new cylinder head with an optimised intake duct. Furthermore, enhanced air supply and airflow have a positive effect on combustion as well as being two of the principal reasons behind the SL 350 model's outstanding flexibility, lower fuel consumption and reduced CO<sub>2</sub> emissions. The smooth-running powerplant produces a full and rich note. Indeed, the SL 350 sounds just as a true V6 sports car should, with visual confirmation provided by the red V on the engine itself.



SL 350

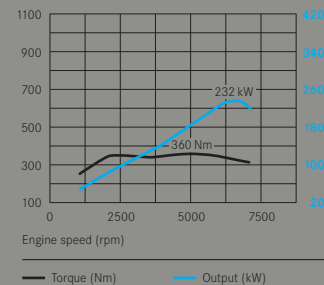





## A virtuoso V8 performance

The power announces itself with an unmistakable eight-cylinder baritone. You can feel the sheer potential of the SL 500 the moment the engine is started. The maximum output of 285 kW (388 hp) is achieved with a level of refinement that is almost without parallel. And with a peak torque of 530 Nm, the SL sprints effortlessly from 0 to 100 km/h in 5.4 seconds.

A special cylinder head was designed for the V8 engine to enable it to achieve these impressive figures: two intake valves and two exhaust valves per cylinder are controlled by means of infinitely variable camshaft adjustment. The result is optimal combustion which, as well as reducing fuel consumption and emissions, boosts the sports car's output and enhances your driving enjoyment. And even if you stop short of taking it to the limit, every drive in the SL 500 is a delight for all the senses. Whether it takes you on long, straight stretches in the country, over cobbled city streets or up twisting mountain roads.

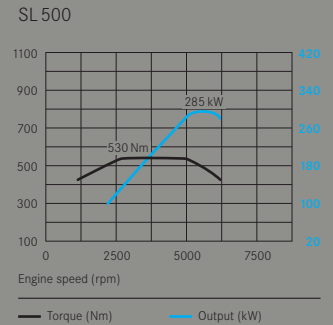



## A heart with twelve chambers: perfect for pumping out the power

Twelve cylinders and two letters – the SL 600. An icon of refinement. But to really make a mark, the figures have to stack up: 380 kW (517 hp), a peak torque of 830 Nm and, above all, acceleration from 0 to 100 km/h in a breathtaking 4.5 seconds.

The V12 engine draws its power from a combination of two turbochargers and an intercooler. A consummate blend of sophisticated Mercedes-Benz engine technologies makes for outstanding responsiveness and maximum torque at low revs, yet still offers lower fuel consumption, not to mention a healthy dose of happiness hormones. Because the sensation of effortless ease you feel as you power ahead in the SL 600 turns every trip into a thoroughly enjoyable driving experience.

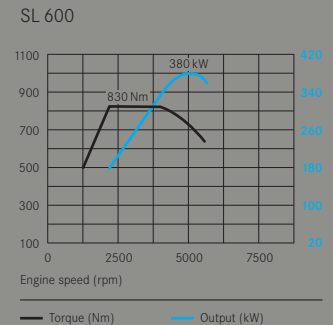





## A show of strength at the filling station as well as out on the road

The SL 280 makes no compromises when it comes to driving enjoyment. The six-cylinder unit developing 170 kW (231 hp) boasts a peak torque of 300 Nm. What's more, it is exceptionally torquy between 2500 and 5000 rpm.

As you get in and start the engine, your pulse quickens. And that's the way it stays. Even after the drive. The feel-good factor continues when you look at the fuel gauge. That's because the SL 280 is extremely economical on fuel - not least thanks to a longer rear-axle ratio of 3.07.

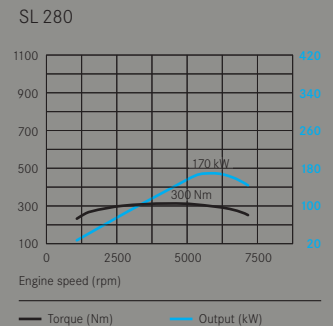





You can't help but  
be moved. Even  
after you stop

## Each gear change merely adds to the driving pleasure

With the very best automatic transmissions, you barely notice the gear changes. So it will come as no surprise that the jumps in engine speed when the 7-speed 7G-TRONIC changes up or down are now smaller than ever before. And when moving down through the gears, the multiple down-shift capability allows several gears to be skipped at once, making for extremely powerful acceleration in any gear.

The 7G-TRONIC is specified as standard for the SL 280, SL 350 and SL 500. These three models also come with the

option of the 7G-TRONIC Sport, which allows manual gear changes as well via steering-wheel gearshift paddles. If you keep the paddle pressed when shifting down, your SL will select the gear offering the best acceleration automatically. The SL 63 AMG is fitted with the new AMG SPEEDSHIFT MCT 7-speed sports transmission, which changes gear in record time without any interruptions in tractive power, thus ensuring the ultimate in driving enjoyment, even when the road speed is fluctuating wildly.

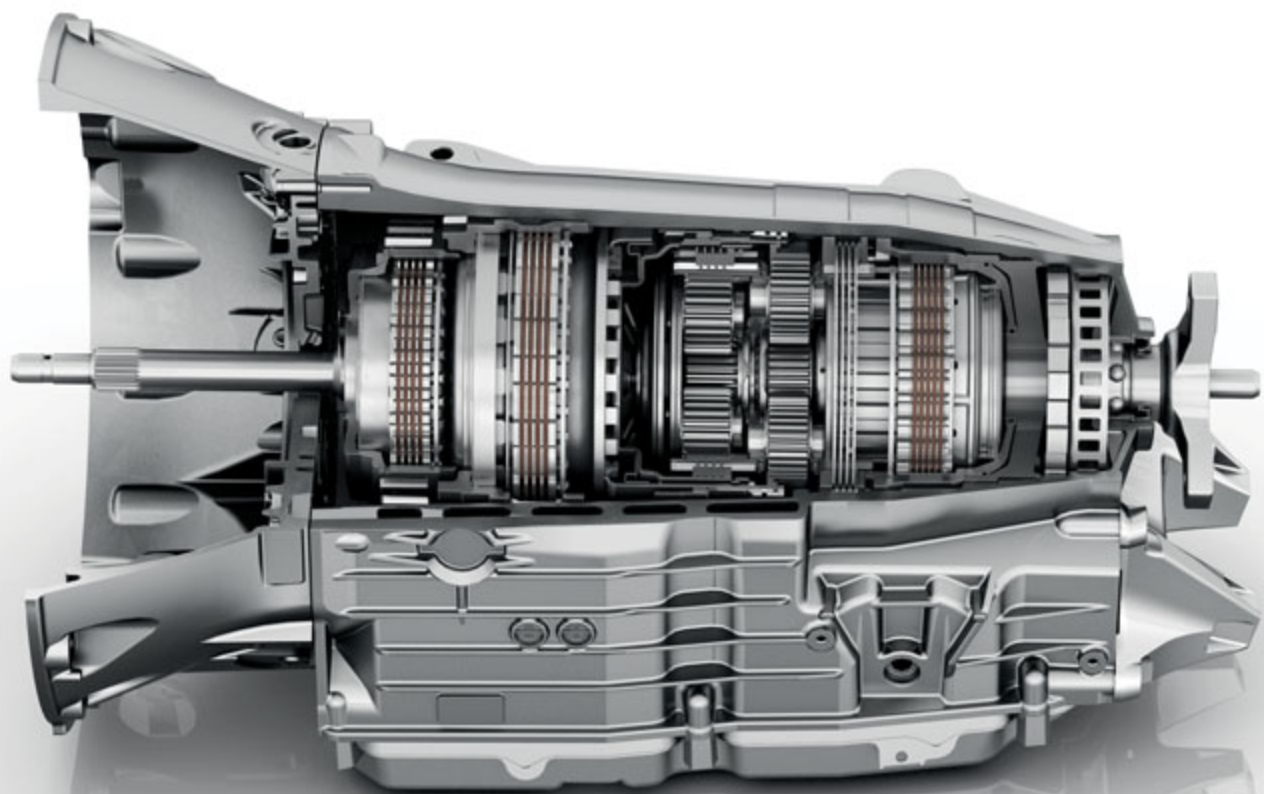

## Good contacts are essential if you spend a lot of time on the road

We don't stop developing a sports car the minute we finish the wheels or the exhaust tailpipes. The road is also part of the perfect driving experience. This is why, when developing Active Body Control ABC, we factored the road into the equation. ABC is specified as standard for the SL 500, SL 600 and AMG models or available as an optional extra for the SL 350.

Ten sensors monitor the driving situation at all times. Hence body movements when setting off and braking are minimised, while lateral movements during cornering are reduced. In sporty mode, the response is enhanced, the suspension

configuration is tauter and the tilting angles are reduced even further. All of which makes for better handling dynamics and improved safety – for example when performing evasive manoeuvres at speed. Safety is also enhanced by the Electronic Stability Program ESP<sup>®</sup>, which acts as a continuous monitoring system and is included as standard on board all Mercedes models. Sensors record driver and vehicle behaviour and then send the gathered data to a microprocessor which, in turn, intervenes by sending specific braking pulses to the individual wheels in critical driving situations.



# The most direct link between the road and the nerve tract

Innovative technology gives you an instinctive feeling for the road, making piloting the SL a sheer, unadulterated pleasure. The standard-fit speed-sensitive power steering does an excellent job, making the car extremely easy to steer when parking, for example, as well as ensuring outstanding straight-line stability when travelling at speed.

The optionally available Direct-Steer system has an even more direct ratio when negotiating tight bends and when parking or manoeuvring. It reduces the steering wheel movements required and, therefore, enhances both comfort and safety. Furthermore, there are fewer steering-wheel turns from lock to lock. What makes the Direct-Steer system so impressive is the fact that you barely notice its presence. Only the ease with which you are able to control your SL gives an inkling that it is there.

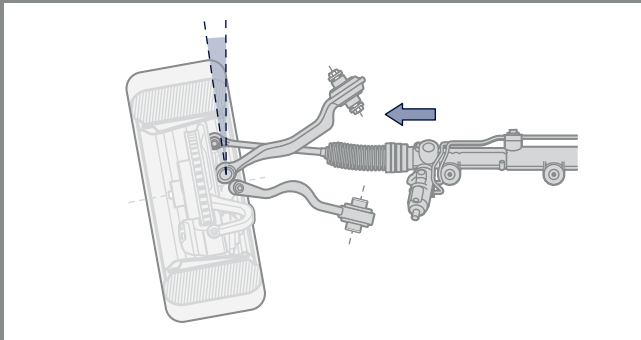

Wheel turn without the Direct-Steer system

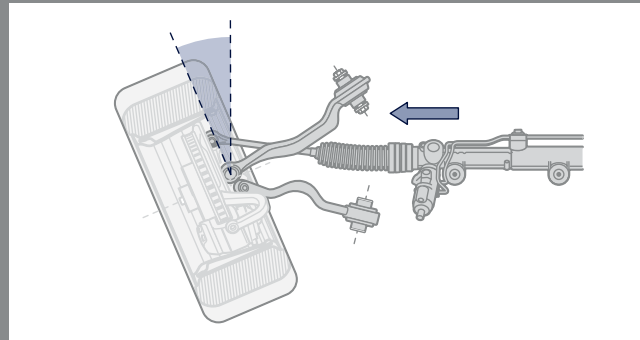

Wheel turn with the Direct-Steer system and the same steering wheel angle





## An idea you'll warm to

Travelling in an SL with the top down is an experience that will never leave you cold – especially when your vehicle is equipped with the innovative AIRSCARF system developed by Mercedes-Benz and available as an option. At the touch of a button, fans at the rear of the head restraints suck in air which is then heated and expelled through an outlet at the front of the seat. Three AIRSCARF settings allow you to

adjust the system for optimum comfort in accordance with your personal preferences, your driving style and the weather conditions. At high speeds, or in cold weather, you can just turn up the system to provide more heat. The air then gently wraps itself around the nape and front of your neck and head area like a warm scarf. And that means you can extend the roadster season for quite a while longer.

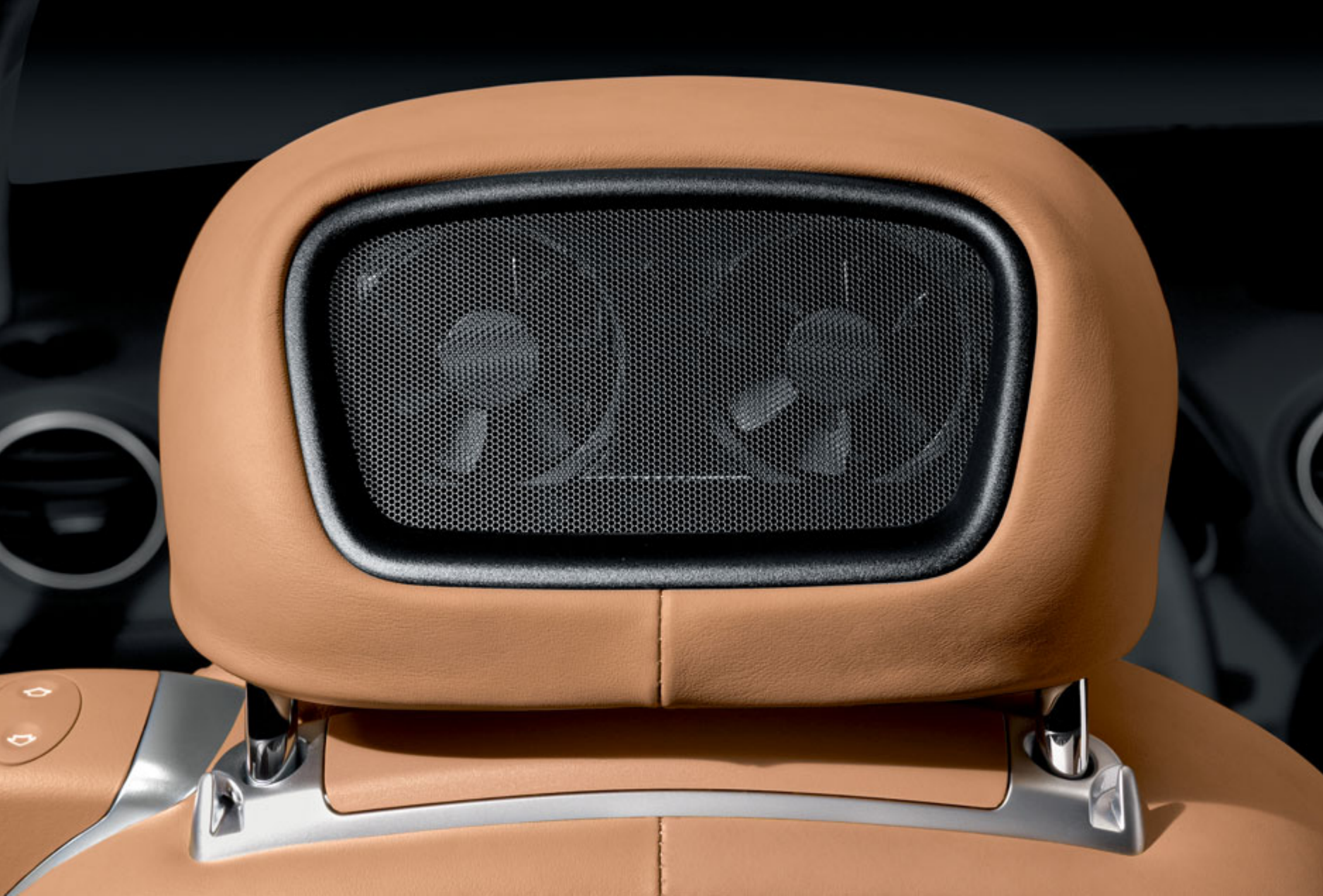



With the right roof, there's no such thing as the wrong weather



The vario-roof is the crowning glory of the SL's outstanding all-round performance, transforming the car into a roadster within a matter of seconds – just 16 to be precise. Thanks to the space-saving design, there are still up to 235 litres of boot capacity available when the roof is stowed in the

rear. This rises to 339 litres when the roof is up. But this Mercedes invention is not just about providing plenty of space for luggage. When the roof is closed, the quietness makes it feel like you are ensconced within a coupé. All noise, dangers, wind and weather simply remain outside.

In fact, the only thing that can top the vario-roof is the panoramic vario-roof. The latter features glass in place of the metal construction, allowing you to enjoy a view that is normally only afforded by a roadster, whilst still revelling in the comfort of a enclosed coupé – whatever the weather.





Normally only a joystick assures this degree of control and precision

The refined sportiness of the SL allows you to experience a whole lot more in addition to the sporty drive. With both hands on the new-look 3-spoke sports steering wheel. Not only does it look dynamic, it also lets you change gear extremely quickly courtesy of a paddle on either side. As well as being sporty, the SL interior boasts an exclusive wood, aluminium or carbon-fibre trim and softly grained leather appointments.

## Needles that are just itching to move

Exclusive dynamism is also a key theme of the SL interior. In terms of design, the new-look 3-D instrument cluster owes much to the world of motor racing. The needles are initially dormant in the 6 o'clock position. Yet they spring into life the moment you insert the key and switch on the







ignition, spinning around their respective dials before returning to the 0 rpm and 0 km/h positions – ready to set off at your command.

Some things that are exciting to watch in action look just as good when they are at rest. The needles are part of the newly designed 3-D-look, chronometer-style instrument cluster. The leather-style trim is embellished with fine topstitching, while the new-look 3-spoke sports steering wheel sits perfectly in the sporty surroundings of the SL cockpit. Shift paddles are standard in the SL 600 and in the sports package while all other models can be equipped with them as an optional extra.



## Two all-weather sports seats

Now a marathon can be pure pleasure. Even on long journeys, your back gets all the support it needs courtesy of the laterally reinforced integral seats in the SL. Whether you are taking tight bends aggressively or cruising serenely along, you are always in the optimal sitting position. Another reason for this is the meticulously crafted seat material available in a choice of leather, nappa leather or Exclusive nappa leather.



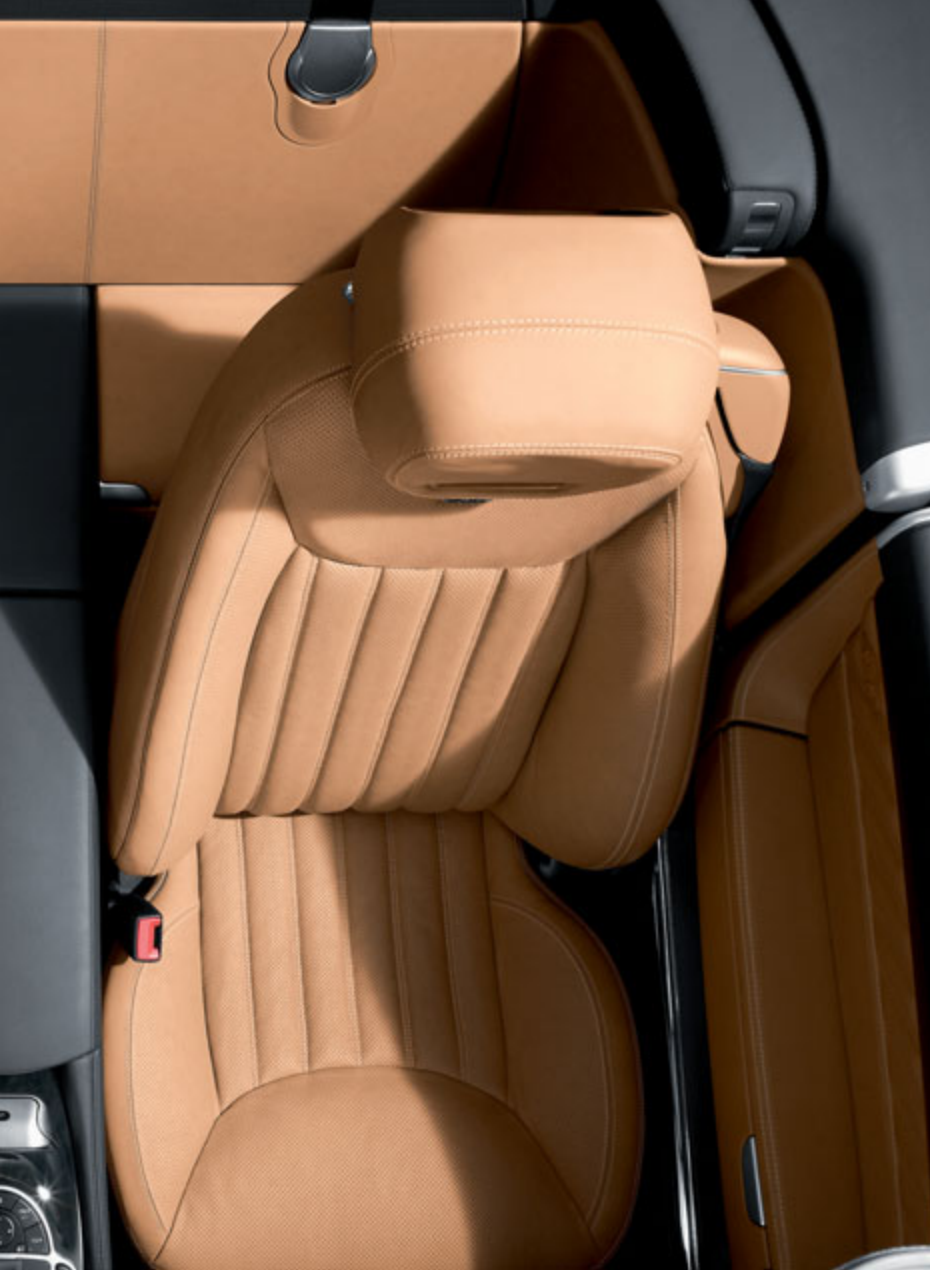

The electrically adjustable seats let you alter your position with ease. The memory function (optional for the SL 280) stores your preferred settings, so a flick of the wrist is all it takes to move the seats to your favourite position the next time you slide behind the wheel. Comfort is therefore assured. It's equally good to know that the standard-fit lumbar supports are behind you: these can be inflated or deflated at the push of a button to provide optimal support for the lower spine, giving you an alert, upright posture. When the weather turns colder, you'll also be pleased that the SL 500, SL 600 and AMG models feature heated seats as standard, ensuring that your daily drive is a treat rather than a torture, even when things turn really frosty. Even the most unpleasant weather conditions cannot spoil your driving enjoyment. The SL 600 and SL 65 AMG also have climatized seats fitted as standard, for pleasant cooling on extremely hot days.

## All legends share one thing above all: timelessness

The twelve-cylinder power also makes its presence felt in the interior of the SL 600. Features that catch the eye immediately when opening the door include the steering wheel and floor mats with V12 styling and the elegant badges on the leather seats. Then there is the harmonious blend of fine poplar trim elements and Exclusive nappa leather appointments.



Even the heart of the most confirmed of perfectionists is sure to start racing after beholding the wealth of harmonious details on display inside the twelve-cylinder model. Such as the unerringly precise double topstitching and the discreet V12 emblems that hint at the power within, even when the car is stationary. Plus there is also the convenience of the KEYLESS-GO system, which allows you to fire the engine of your SL without having to use a key. Simply hit the start button. Further standard equipment available for the SL 600 includes remote boot lid closing, climatized seats and a convenience telephone system. So there can be no doubt: it's not just the 12 cylinders beneath the bonnet that make the SL 600 unique.



## An SL that hangs on your every word

The standard-fit COMAND multimedia system on board the SL groups together entertainment and navigation functions in one central unit. Optional navigation functions and films are shown at eye level on the generously sized 6.5-inch colour display. You can even watch television here if the optionally available TV receiver is specified. The 6-disc CD/DVD changer for audio or video is within easy reach, while an optionally available media interface allows COMAND to connect to any USB data source, an iPod® or Aux-in device. So you can play music or videos from an external hard drive, for example.





The optionally available COMAND APS system features an integral hard drive containing the navigation software – leaving the CD drive free for alternative uses – and 4 GB of memory for audio files in MP3 or WMA format. If music isn't your thing, your SL lets you do the talking. The voice-operated control system LINGUATRONIC allows you to control COMAND APS functions such as the radio and telephone using voice commands.



# The first concert hall able to go on tour

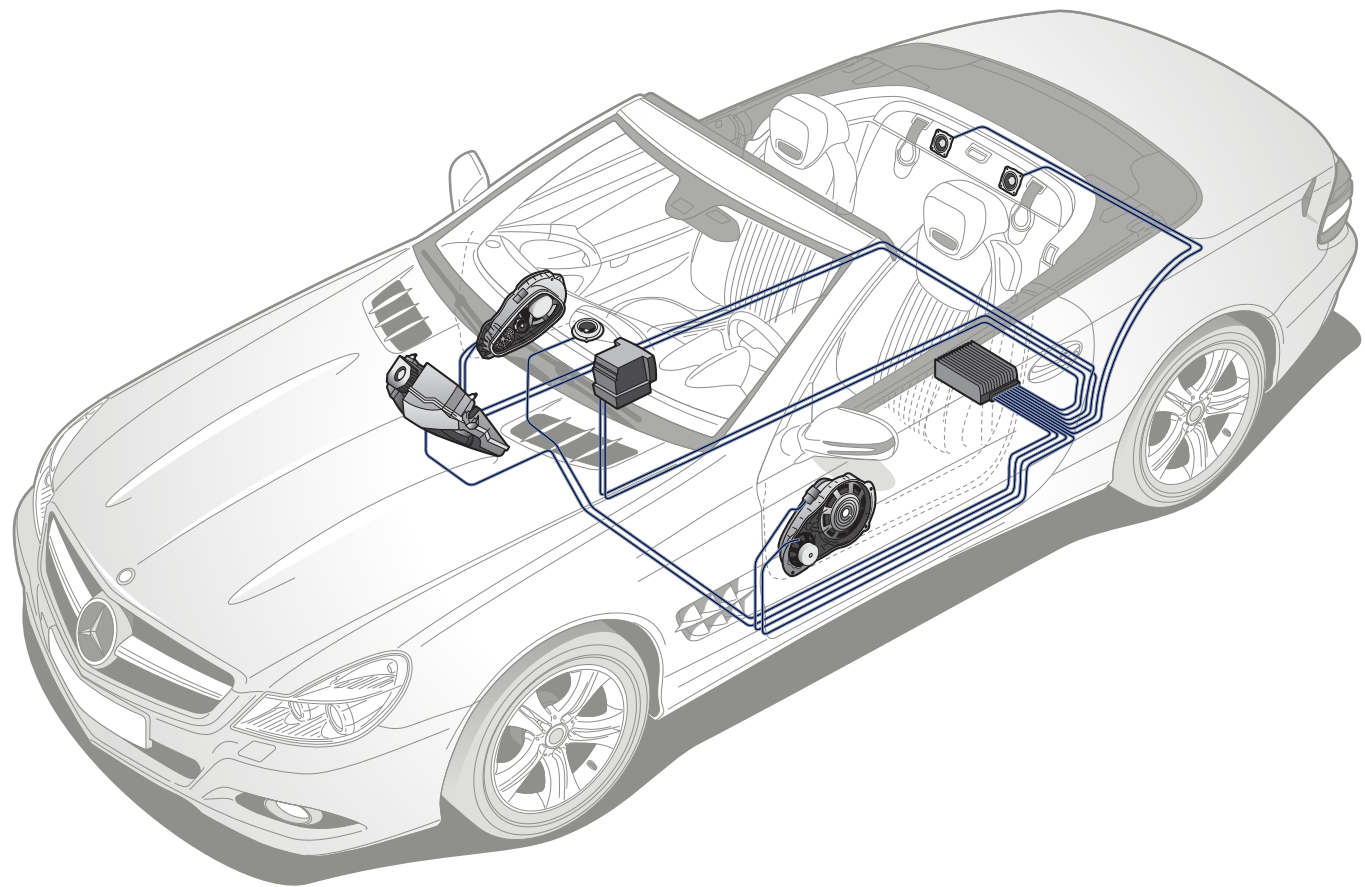





The SL seems almost too small to deliver such a monumental listening experience. The sound waves produced by the optionally available Harman Kardon® Logic 7® surround sound system fan out as in a concert hall thanks to 10 high-performance loudspeakers, including two surround speakers and a subwoofer.

Allow the interior to flood with sound courtesy of Dolby digital technology – just like at the cinema. So should you on occasion wish to change the soundtrack provided by the six, eight or twelve-cylinder powerplant, you can always turn to the audio system.

## Only one thing is ahead of you in the SL: the safety systems

It all began with an invisible revolution. When Mercedes-Benz unveiled the first car to be designed with passive safety aspects in mind in 1959, the innovations – crumple zones and the safety passenger cell – were invisible to the naked eye. Then airbags and seat belt tensioners – both world firsts – came along. Since then, of course, we have never let up in our quest to always go one step further than required when it comes to safety. Should you have an accident today, sophisticated, efficient occupant protection systems help reduce the risk of injury dramatically. Self-protection is also enhanced by the high-strength safety passenger cell and systems such as adaptive airbags. And if the worst comes to the worst, the roll-over bar pops up automatically within a fraction of a second.

The SL even helps to provide greater safety after an accident, for instance with a fuel tank situated in a protected position ahead of the rear axle, or the automatic engine cut-off function which is triggered after a severe collision. Automatic activation of the hazard warning lamps makes it easier to locate a car which has been involved in an accident. And doors which unlock automatically and are easily opened mean that occupants can be rescued more quickly after an accident. This safety philosophy is rounded off by a multilingual rescue guide which was specially developed for rescue services and which can be accessed on the internet at [www.mercedes-benz.com/rescue-guidelines](http://www.mercedes-benz.com/rescue-guidelines)



ABS ensures that the car remains directionally stable and steerable, even during emergency braking. The driver is able to brake and steer simultaneously – allowing precise evasive manoeuvring – in order to avoid an accident

ESP® enables outstanding directional stability and road adhesion by counteracting any possible tendency to skid at the outset. It intervenes in the engine-management and braking systems as required in order to stabilise the car

Electronic control of the braking system allows a wealth of key assistance functions that help to further enhance active safety and comfort in a whole range of driving situations, thus making life much easier for the driver

During emergency braking, BAS ensures that the maximum brake pressure is applied, even if the brake pedal is not pressed hard enough, thus shortening the stopping distance by a substantial margin



## Only two seats. But a wealth of assistance systems

Even the most enjoyable of journeys can come to an abrupt end. Now you can continue on your way, even after an emergency stop, thanks to the hundreds of sensors on board the SL. Such as the electrohydraulic ADAPTIVE BRAKE system which monitors driver and car behaviour on a permanent basis. In critical situations, the pressure in the brake lines is increased and the pads are applied on the brake discs. A dab of the brake pedal is then all that is needed to decelerate the SL with the full braking power. In addition, the ADAPTIVE BRAKE increases safety when braking on bends and detects wet road surfaces. It brakes the brake discs dry when required and also reduces the pitching motion of the brake pedal when the anti-lock braking system ABS intervenes to counteract locking-up of the wheels by delivering the brake pressure in short bursts. This means that you remain firmly in control, even in the most precarious of situations. The Electronic Stability Program ESP® also applies the brakes at each individual wheel as required to assist with the prevention of tail-skids, oversteer or understeer, while Brake Assist (BAS) helps to shorten the braking distance. BAS detects emergency braking and helps to provide the maximum braking power within a fraction of a second. Meaning that the car comes to a halt – and hopefully continues on its way again afterwards – in as short a time as possible.

# Flexible lighting to keep you on the move in the dark

Extremely sporty yet safe driving requires all your senses to be alert. Plus you need reliable sensors that help to detect possible dangers at an early stage. Active components of the safety concept include extremely powerful lights such as the bi-xenon headlamps specified as standard for the new SL. The optional Intelligent Light System also includes an integrated cornering light function.

They illuminate the road far more effectively than conventional halogen lights, allowing you to see much further ahead and giving you a much better perspective. All of which makes for exceptionally safe driving at night. So there's no need to be afraid of the dark.

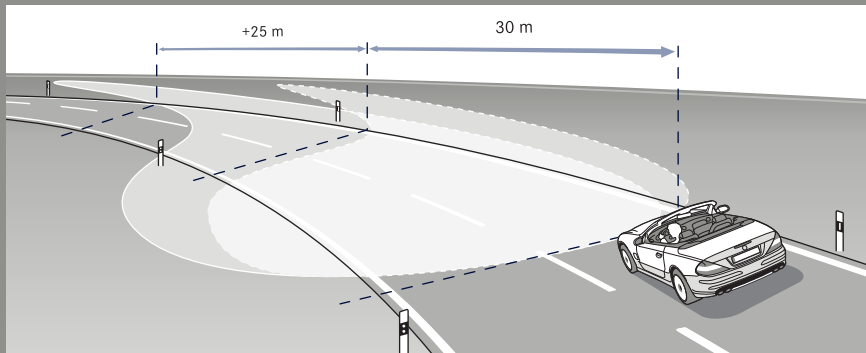



S SL 6310

Pure power that  
makes you go weak  
at the knees









## AMG: the name speaks volumes; the performance speaks for itself

In what is quite literally a show of strength, the AMG body-styling accentuates the muscular forms of the SL 63 AMG perfectly.

The exterior of the super sports car is dominated by the impressive AMG bonnet at the front and the dynamic AMG spoiler lip at the rear. The design comes to a rousing conclusion in the shape of an AMG sports exhaust system with two chromed twin tailpipes.

The SL 63 AMG boasts new 19-inch AMG triple-spoke light-alloy wheels. AMG high-performance brakes with compound brake discs and 6-piston brake callipers are visible behind the front wheels. What's more, the brakes back up their powerful looks by delivering maximum performance – all in true AMG style.



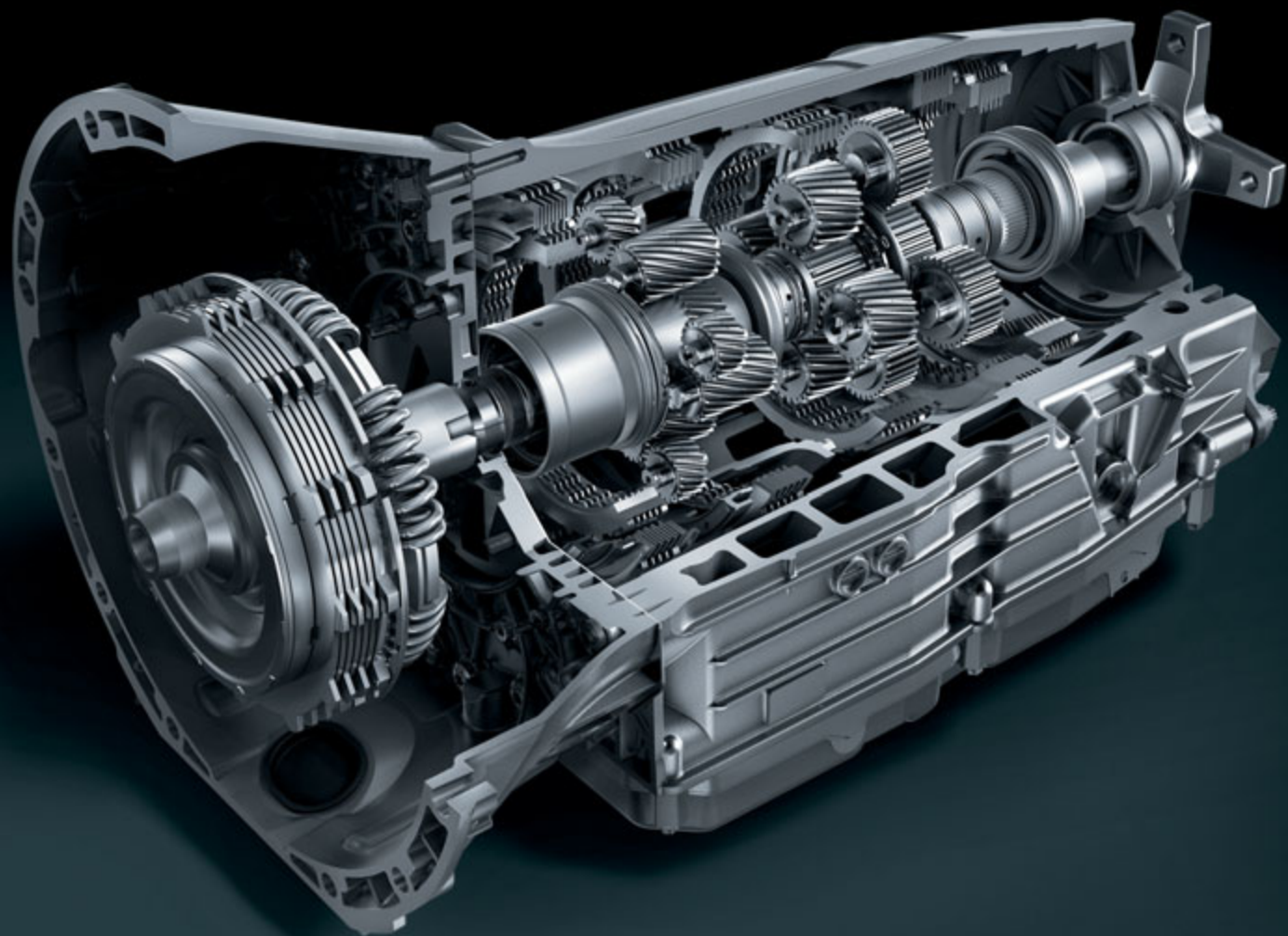



## Short on shift times, long on driving pleasure

The SL 63 AMG takes your breath away and makes you forget any everyday woes. Its large-displacement AMG 6.3-litre V8 engine develops 386 kW (525 hp) and delivers a peak torque of 630 Nm. This is handled with consummate ease by the innovative AMG SPEEDSHIFT MCT 7-speed sports transmission in the SL 63 AMG which offers you a choice of four modes, ranging from dynamic manual shifts to comfortable cruising. So you ultimately decide how the formidable power of the SL 63 AMG is to be unleashed.

These features, like all the other dynamic handling control functions, can be controlled centrally for the first time thanks to the new AMG DRIVE UNIT.

Furthermore, the AMG sports transmission features a Race Start function for optimal acceleration and traction – just as in the world of motorsport.







## To control power is good. To master it is even better

Powered by an AMG 6.0-litre V12 biturbo engine with an output of 450 kW (612 hp) and a peak torque of 1000 Nm, the SL 65 AMG is one of the world's most powerful production roadsters. Extremely impressive performance – in the form of stopping power – is also delivered by the AMG high-performance braking system with compound brake discs measuring 390 mm in diameter at the front and 360 mm at the rear. The SL 65 AMG is clearly recognisable from afar on account of its new 19-inch AMG twin-spoke forged wheels and the front-apron cross strut painted in matt silver. Then there are the AMG side skirts and an AMG rear apron. Two twin tailpipes featuring AMG V12 styling give the car an effortlessly superior air at the rear. And the performance clearly hinted at on the outside is matched by the level of exclusivity inside: the interior is appointed in fine Exclusive nappa leather featuring an AMG V12 diamond design. Along with the AMG sports steering wheel with aluminium shift paddles, genuine carbon-fibre trim elements underline the sporting credentials of this unique roadster.









## Choosing the SL could be the easiest decision you'll ever have to make

The ability to combine sportiness and dynamism at the highest level is one of our greatest strengths. And nowhere is this demonstrated more perfectly than at the AMG *PERFORMANCE STUDIO* - home to the Affalterbach individualisation experts. The AMG performance package for the SL 63 AMG features components that have been specially configured for maximum performance: performance suspension, larger compound brake discs at the front and a rear-axle differential lock. Not to mention the 19-inch AMG twin-spoke forged wheels and the more compact AMG performance steering wheel with its specially flattened bottom section.



The exterior carbon-fibre package is designed primarily to enhance visual expressiveness. It features side air outlets, exterior mirrors, a spoiler lip and a diffuser insert made from carbon fibre as well as optional AMG door sill panels with white illumination.



S 0U 9353



## The only racing attire that also looks good at a business meeting

SL-Class Roadsters have always attracted admiring glances, an effect which can be boosted by adding AMG bodystyling. It consists of a powerful front apron with larger cooling-air intakes and integrated fog lamps, side skirts and a rear apron with a black insert. The dynamic look is completed by 19-inch AMG 5-spoke light-alloy wheels.







## An official member of the elite

The racing season: as good a time as any to experience the breathtaking SL. As a driver on the road. Or as a spectator at the racetrack, where the SL 63 AMG has been on duty as the official Formula 1 Safety Car since the start of the 2008 season. Bernd Mayländer is at the wheel of one of racing's most important vehicles on some of the world's most demanding motorsport circuits. Followed by the world's fastest racing cars.

The SL 63 AMG fits the bill here perfectly, combining a powerful AMG V8 engine with a new innovative AMG sports transmission. The result is an especially intensive driving experience which you can share with Bernd Mayländer. What you can't have though is the signalling system and official FIA F1™ lettering.





My SL



The sports package





Some athletes are happy to just take part. Others are there to win. The SL with the sports package falls into the latter category. The package is available for the SL 280, SL 350 and SL 500 models. Visual enhancements include 19-inch 5-twin-spoke light-alloy wheels as well as darkened headlamps and tail lights, while the braking system features perforated front and rear discs along with painted brake

callipers – ready to provide maximum deceleration. The 7G-TRONIC Sport automatic transmission and steering-wheel shift paddles allow extremely fast gear changes, with the ratio offering the best acceleration being selected straight away every time. It feels good. And it sounds good too – thanks to the sports air cleaner developed specifically for the SL 280 and SL 350.



Enough sport for an entire team



What the SL with the sports package promises on the outside is delivered on the inside: exclusivity and sportiness at the highest level. Starting with the black leather appointments with silver contrasting stitching. A design element that ensures clear accentuation, it embellishes the centre console, dashboard, armrests and the velour floor mats as well. Without the eye-catching stitching, the grey leather

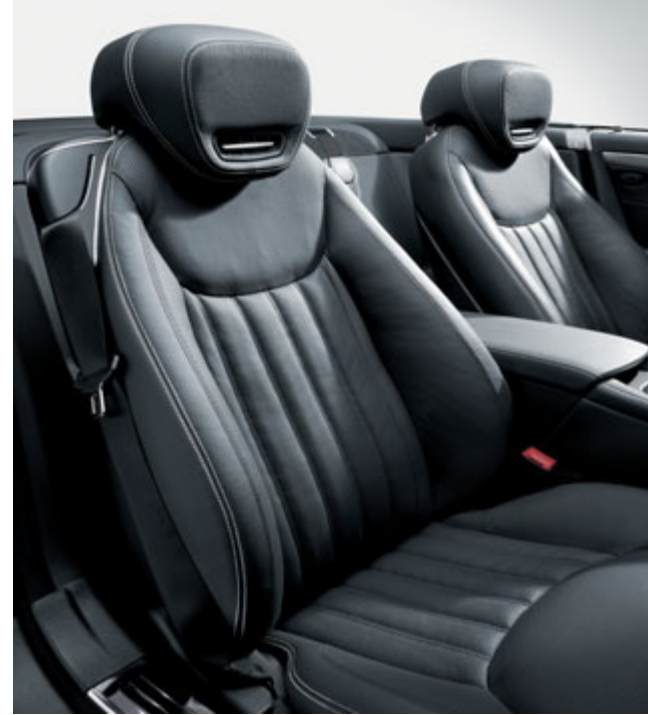

appointments impress instead with their discreetly understated look. In both variants, the steering wheel and selector lever are trimmed in perforated leather, their easy-grip design mirroring the high quality. This unique interior look is enhanced by prism-pattern aluminium trim elements that create a pleasing contrast which is further accentuated by the black roof liner.



Exterior mirrors



Draught-stop



The new-look 3-spoke sports steering wheel



COMAND display in the centre console

**Standard equipment (selection)**

Active Body Control ABC (optional for SL 350, not available for SL 280)	Heated exterior mirrors, electrically adjustable, with aspherically curved mirror glass
Adaptive brake lights featuring LED technology	Indicator repeaters in the exterior mirrors
Airbags for driver and passenger plus head/thorax sidebags	Infrared remote control for roof
Anti-theft alarm system with tow-away protection	Light-alloy wheels
Armrest/centre console with stowage compartment	Loading aid for the boot (EASY-PACK system)
ASSYST service interval indicator	Metal door-sill panels
Automatic climate control with combination filter and residual heat utilisation	Multifunction steering wheel
Automatic transmission	Outside temperature display
Bi-xenon headlamps with headlamp cleaning system and dynamic range control	Parcel net in passenger footwell
Brake Assist (BAS)	Power socket (12 V) in boot
COMAND with integral radio, 6.5-inch colour display with DVD changer, MP3-compatible, Bluetooth interface, Aux-in socket, 8 loudspeakers	Rain sensor
Cruise control with SPEEDTRONIC variable speed limiter	Remote boot-lid release
Draught-stop (optional for SL 280)	Removable luggage cover
Electrically adjustable seats, with lumbar support and memory function (optional extra for SL 280)	Roll-over bar with crash sensor, automatically raised
Electrically adjustable steering column, with memory function (optional extra for SL 280)	Seat belt tensioners and belt force limiters for driver and passenger
Electrohydraulic braking system with start-off assist	Speed-sensitive power steering with safety steering column
Electronic Stability Program ESP®	Steering wheel and selector lever in leather (wood/leather in SL 600)
Exit lights in the doors	Tinted windows all round
Headlamp Assist	Tyre pressure loss warning system
	Ventilated glove compartment

## SL light-alloy wheels

A wide range of wheels is available for the different engine versions of the SL. 18-inch 5-spoke light-alloy wheels are standard on the SL 500, while the SL 600 is delivered ex-factory with 18-inch V12-design light-alloy wheels. 18-inch 5-twin-spoke light-alloy wheels are available as optional extras for the SL 350, the SL 500 and the SL 600. Distinctive 19-inch five-twin-spoke light-alloy wheels are fitted as standard in conjunction with the sports package or as an optional extra for the SL 600.



17-inch 5-spoke light-alloy wheels (standard on SL 280)



17-inch 5-twin-spoke light-alloy wheels (standard on SL 350)



18-inch 5-spoke light-alloy wheels (standard on SL 500)



18-inch 5-twin-spoke light-alloy wheels (optional extra)



18-inch light-alloy wheels with V12 styling (standard on SL 600)



19-inch 5-twin-spoke light-alloy wheels (standard with sports package, optional extra on SL 600)

# The AMG and incenio light-alloy wheels for your SL



19-inch AMG 5-spoke light-alloy wheels



19-inch AMG triple-spoke light-alloy wheels



19-inch AMG twin-spoke forged wheels





incenio "Gorgona" 17-inch 5-spoke designer wheel



incenio "Veseli" 18-inch 5-twin-spoke designer wheel



incenio "Nash" 18-inch 9-spoke designer wheel



incenio "Tarka" 19-inch 5-spoke designer wheel



We only ever adapt the SL to meet your needs



The SL-Class features extremely comfortable, laterally reinforced integral seats that adjust electrically with ease and remember your preferred sitting position thanks to the memory function (standard in all models except the SL 280). An even more relaxing driving experience is available with the climatized seats, which are fitted as standard in the SL 600 and SL 65 AMG, and are optional for all other models.

These perforated seats are equipped with an active ventilation system for fast cooling on hot days. Optional multicontour seats (standard in the SL 63 AMG and SL 65 AMG) have integral air cushions that adjust to your body and also offer a massage function: air chambers pulsate gently at the touch of a button to ease tense back muscles.



AMG bodystyling: front apron



Head restraint with AIRSCARF



AMG bodystyling: rear apron



Intelligent Light System: headlamp

Optional extras (selection)	SL 280	SL 350	SL 500	SL 600	SL 63 AMG	SL 65 AMG
7G-TRONIC Sport 7-speed automatic transmission including steering-wheel gearshift paddles	●	●	●	–	–	–
Active Body Control ABC	–	●	○	○	○	○
AIRSCARF	●	●	●	●	●	●
AMG bodystyling	●	●	●	●	○	○
COMAND APS, including hard-disc navigation for digitalised regions of Europe, MUSIC REGISTER and voice-operated control system LINGUATRONIC	●	●	●	○	●	○
Direct-Steer system with variable servo assistance	●	●	●	●	–	–
DISTRONIC	●	●	●	●	●	●
Harman Kardon® Logic 7® surround sound system with output of 510 watts, 10 loudspeakers and Dolby 5.1/DTS	●	●	●	○	●	○
Heated windscreen washer system	●	●	●	●	○	○
Intelligent Light System (ILS) including cornering light function	●	●	●	●	●	●
KEYLESS-GO	●	●	●	○	●	○
Media interface: universal interface for various audio devices (e.g. iPod®, USB memory device, etc.) <sup>1</sup>	●	●	●	●	●	●
Memory package for both seats, steering column and exterior mirrors	●	○	○	○	○	○
Multicontour seats, left and right	●	●	●	●	○	○
Panoramic vario-roof	●	●	●	●	●	●
PARKTRONIC	●	●	●	○	●	○
Sports package	●	●	●	–	–	–
TV tuner (for analogue and digital TV reception)	●	●	●	●	●	●
Tyre pressure monitoring system	●	●	●	●	●	○

● Optional extra

○ Standard equipment

– Not available

<sup>1</sup> Adapter lead available from accessories range



Practical accessories



From practical roof-rack systems to snow chains, the range of genuine Mercedes-Benz accessories includes a whole host of attractive, high-quality and useful items for your SL. A prime example is the rear shelf bag developed and designed specifically for the SL. It is a perfect fit for the area behind the seats and is made from fine materials such as

smooth cowhide nappa leather. You can even order the bag in one of three original seat colours. The intelligent interior layout of the bag makes it extremely versatile. Please consult our accessories catalogue or contact your Mercedes-Benz dealer for further details.

A close-up photograph of a silver, oval-shaped button with the word "designo" written in a black, serif font. The button is set against a light-colored, perforated metal surface, likely a speaker grille, which features a regular grid of small circular holes. The lighting is soft, highlighting the metallic sheen of the button and the texture of the perforated surface.

designo



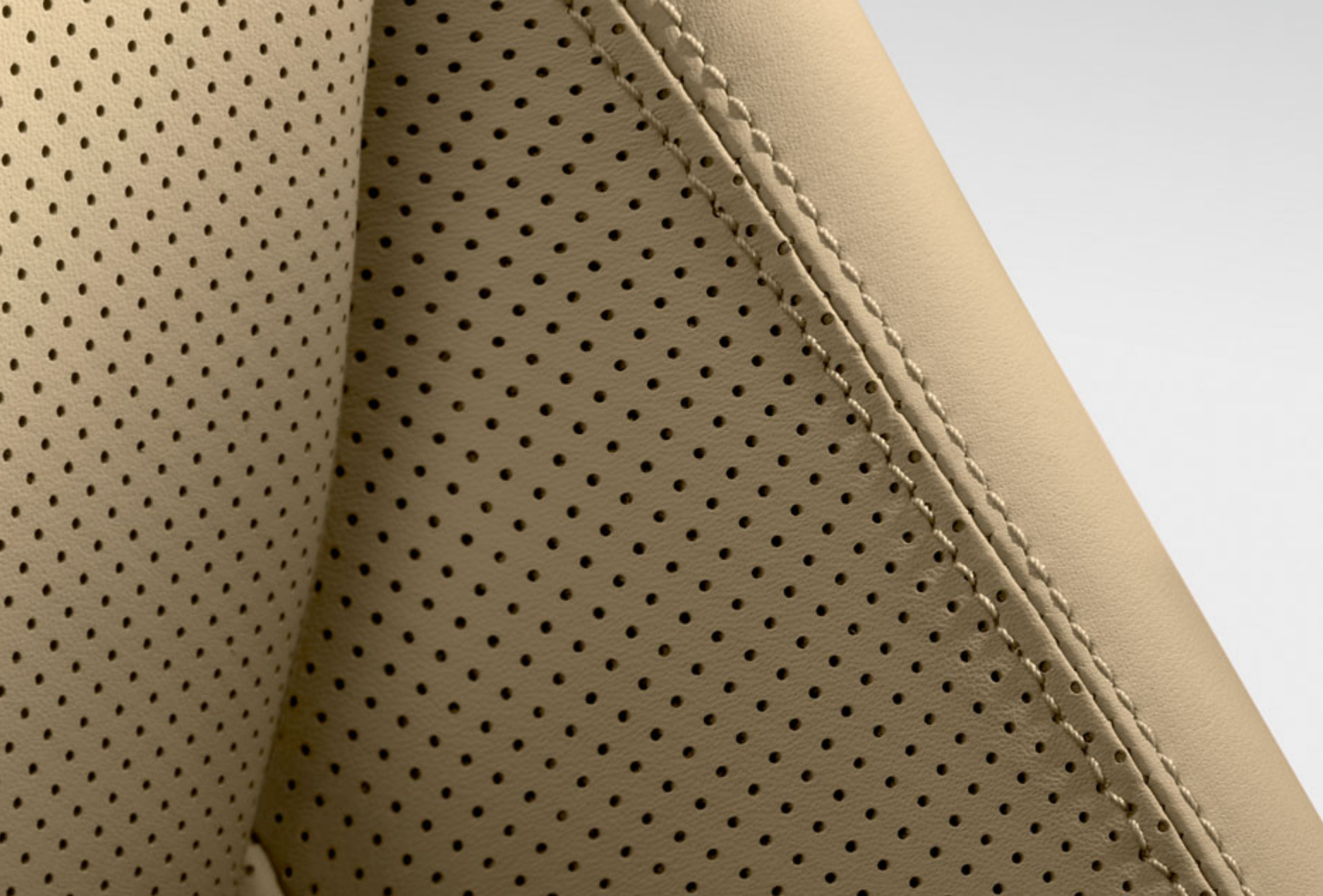

Inside, too, your wish is our command: eleven single-tone and two-tone designo leather upholstery finishes are available for the SL. But the choice of upholstery colour is only the first of many decisions. Would you prefer classic designo leather or the even finer designo EXCLUSIVE leather? We vary the Exclusive nappa leather appointments that form the basis for the designo upholstery effectively by adding touches in the selected designo colour, from the dashboard to the parcel shelf. A designo Alcantara trim in a choice of three colours is available as an optional extra for the roof liner, A-pillars and C-pillars.

The range of designo trim elements comprises a selection of woods as well as fine natural stone. Maple grain with a designo natural finish, designo black piano lacquer or oak grain with a designo matt natural finish lend the interior a warm atmosphere. By contrast, the Labrador blue pearl and black Star Galaxy stone trims make an elegantly sporty statement. In addition, there are nine exclusive designo metallic paints available.









Centre console in designo black piano lacquer (W69) with selector lever in designo black leather



Trim in designo black piano lacquer (W69) and door centre panel with characteristic piping look in designo pastel grey leather (X 12)

You can count on our vehicles' good looks to last. A specially-developed clearcoat – one of the best on the automotive market – guarantees this. The paint features a particularly dense molecular structure, which makes it more resistant and at the same time creates a more intense, extremely durable shine. Irrespective of whether it is non-metallic or metallic, this scratch-resistant clearcoat is insensitive to weather and environmental influences as well as precipitation, sunlight and temperature fluctuations. The paint finish of the SL is a brilliant final touch to the sophisticated Mercedes-Benz corrosion-protection system which includes a coating of zinc phosphate for long-lasting protection. In addition, for reasons of environmental compatibility, we only use water-based paints, whose solvent content is up to 80 percent lower than that of conventional paints.

#### NON-METALLIC PAINT FINISHES



040 black

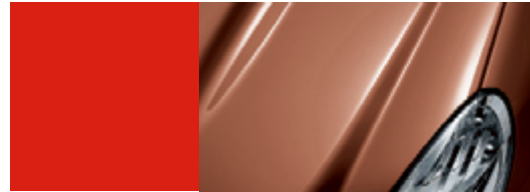

590 fire opal

#### METALLIC PAINT FINISHES



112 chromite black

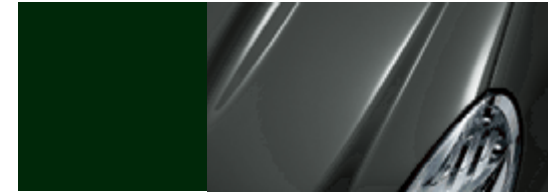

197 obsidian black



359 tanzanite blue

SPECIAL PAINT FINISH



541 thulite red



775 iridium silver



779 alabandite grey

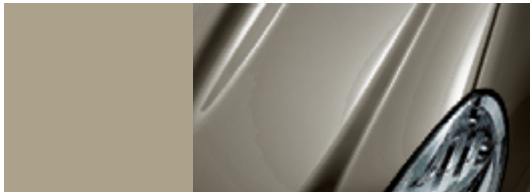

723 cubanite silver



792 palladium silver



755 tenorite grey

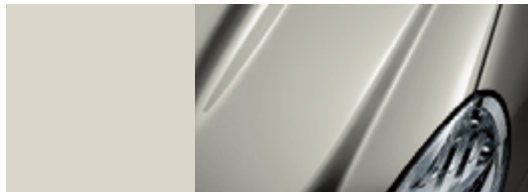

799 diamond white BRIGHT

## LEATHER

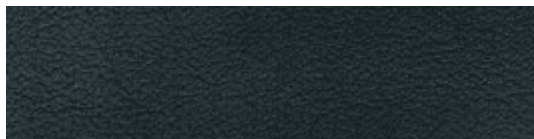
211 black<sup>1</sup>214 natural beige<sup>1,2</sup>215 pebble beige<sup>1</sup>217 flamenco red<sup>1</sup>218 alpaca grey<sup>1</sup>

## NAPPA LEATHER

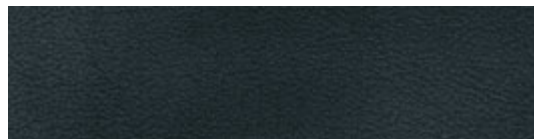
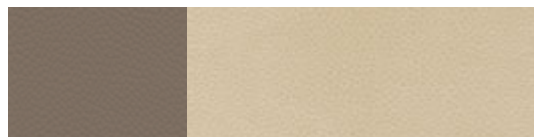
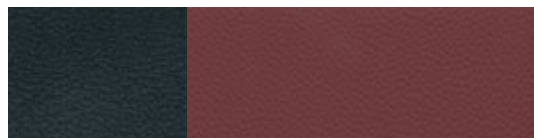
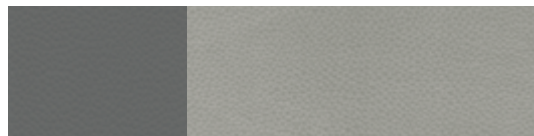
801 black<sup>3</sup>804 natural beige<sup>2,3</sup>805 pebble beige<sup>3</sup>807 flamenco red<sup>3</sup>808 alpaca grey<sup>3</sup>

## EXCLUSIVE NAPPA LEATHER

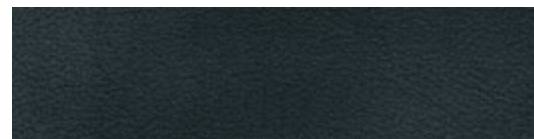
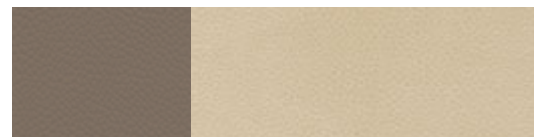
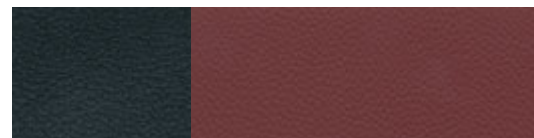
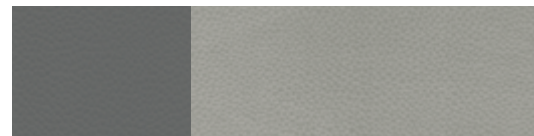
511 black<sup>4</sup>514 natural beige<sup>2,4</sup>515 pebble beige<sup>4</sup>517 flamenco red<sup>4</sup>518 alpaca grey<sup>4</sup>



## LEATHER/COMO FABRIC

black<sup>5</sup>

## SPORTS PACKAGE

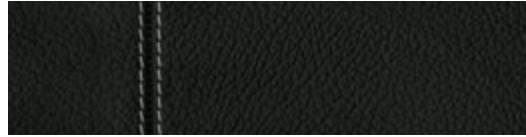
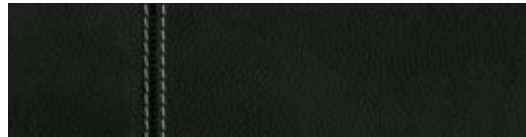
221 black leather<sup>6</sup>811 black nappa leather<sup>6</sup>521 black Exclusive nappa leather<sup>6</sup>

228 grey leather



828 grey nappa leather



528 grey Exclusive nappa leather

<sup>1</sup> Optional extra for SL 280 and SL 350, standard for all other models<sup>2</sup> Not available for SL 63 AMG and SL 65 AMG<sup>3</sup> Optional extra<sup>4</sup> Optional extra, standard for SL 600 and SL 65 AMG<sup>5</sup> Standard for SL 280 and SL 350, not available for any other models<sup>6</sup> Leather with silver stitching

## TRIM ELEMENTS

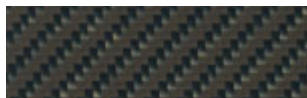
739 aluminium<sup>1</sup>H73 carbon fibre<sup>2</sup>H75 prism-pattern aluminium<sup>3</sup>

## WOOD

729 pale poplar<sup>4</sup>731 burr walnut<sup>5</sup>736 black ash<sup>6</sup>H12 pale burr walnut<sup>6</sup>

## designo ALCANTARA ROOF LINER



Y83 anthracite



Y84 pebble beige



Y85 alpaca grey

## designo TRIM ELEMENTS



W21 designo matt natural oak grain



W64 designo natural maple grain

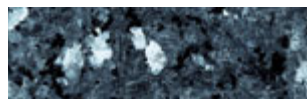

W69 designo black piano lacquer

W72 designo stone - Labrador  
blue pearl

W73 designo stone - Star Galaxy

<sup>1</sup> Standard for SL 280 and SL 350, no-cost option for SL 500, not available for SL 600, SL 63 AMG, SL 65 AMG

<sup>2</sup> Standard for SL 63 AMG and SL 65 AMG, not available for any other models

<sup>3</sup> Prism-pattern aluminium is part of the sports package and not available separately

<sup>4</sup> Standard for SL 600, not available for any other models

<sup>5</sup> Standard for SL 500 and SL 600, optional extra for SL 280 and SL 350, no-cost option for the AMG models

<sup>6</sup> Optional extra for SL 280 and SL 350, no-cost option for all other models

	Leather/ Sienna fabric <sup>1</sup>	black	Leather <sup>2</sup> / Nappa leather <sup>3</sup> / Exclusive nappa leather <sup>4</sup>	black	natural beige	flamenco red	pebble beige	alpaca grey
<b>NON-METALLIC PAINTS</b>								
black		●		●	●	●	●	●
fire opal		●		●	○	△	○	○
<b>METALLIC PAINTS</b>								
chromite black		●		●	●	●	●	●
obsidian black		●		●	●	●	●	●
tanzanite blue		●		●	●	△	●	●
thulite red		●		●	○	●	●	○
cubanite silver		●		●	○	○	●	△
tenorite grey		●		●	●	●	○	●
iridium silver		●		●	●	●	△	●
palladium silver		●		●	△	●	●	●
diamond white BRIGHT		●		●	●	●	○	●
<b>SPECIAL PAINT</b>								
alabandite grey		●		●	○	△	○	●

● Recommended    ○ Possible    △ Not recommended

<sup>1</sup> Standard for SL 280 and SL 350, not available for any other models

<sup>2</sup> Optional extra for SL 280 and SL 350. Standard for all other models

<sup>3</sup> Optional extra

<sup>4</sup> Optional extra, standard for SL 600 and SL 65 AMG

A Mercedes embodies a real sense of freedom – something you'll begin to experience when you specify your future car by choosing your ideal configuration from the wide range of possible combinations. If this seems a little daunting, we can help you – with our vehicle configuration tool at [www.mercedes-benz.de](http://www.mercedes-benz.de), for example. This allows you to take your time putting your Mercedes together in the form of a virtual model before ordering the real thing from us. Or you can opt for the almost unlimited freedom presented by the designo range and create an SL which reflects your tastes in every respect. Freedom is there to be embraced, after all.

	SL 280	SL 350	SL 500	SL 600	SL 63 AMG	SL 65 AMG
No. of cylinders/arrangement	6/V	6/V	8/V	12/V	8/V	12/V
Total displacement (cc)	2996	3498	5461	5513	6208	5980
Rated output <sup>1</sup> (kW at rpm)	170/6000	232/6500	285/6000	380/5000	386/6800	450/4800
Rated torque <sup>1</sup> (Nm at rpm)	300/2500-5000	360/4900	530/2800-4800	830/1900-3500	630/5200	1000/2000-4000
Acceleration from 0 to 100 km/h (s)	7.8	6.2	5.4	4.5	4.6	4.2
Top speed <sup>2</sup> , approx. (km/h)	250	250	250	250	250	250
Tank capacity/fuel (l)	80/Premium unleaded	80/Premium unleaded	80/Premium unleaded	80/Super Plus	80/Super Plus	80/Super Plus
Fuel consumption <sup>3</sup> (l/100 km) urban/extra-urban/combined	13.5/7.0/9.4	14.3/7.4/9.9	18.1/8.3/11.9	21.3/9.5/13.9	21.4/9.5/13.9	23.4/10.4/15.1
CO <sub>2</sub> emissions <sup>3</sup> (g/km), combined	224	236	284	330	330	362
Kerb weight <sup>4</sup> (kg)/perm. gross vehicle weight (kg)	1815/2110	1825/2120	1910/2205	2045/2320	1970/2225	2120/2385
Tyre size						
front	255/45 R 17	255/45 R 17	255/40 R 18	255/40 R 18	255/35 R 19	255/35 R 19
rear	255/45 R 17	255/45 R 17	255/40 R 18	285/35 R 18	285/30 R 19	285/30 R 19
Boot capacity, incl. luggage recess (l)						
Roof up	339	339	339	339	339	339
Roof down	235	235	235	235	235	235

<sup>1</sup> Figures according to Directive 80/1269/EEC in the currently applicable version

<sup>2</sup> Electronically limited

<sup>3</sup> The figures shown were obtained in accordance with the prescribed measuring process (Directive 80/1268/EEC in the currently applicable version). The figures are not based on an individual model and do not constitute part of the product offer; they are provided solely for purposes of comparison between different vehicle models

<sup>4</sup> Figures according to Directive 92/21/EC, version 95/48/EC (kerb weight with fuel tank 90% full, driver, 68 kg, and luggage, 7 kg) for standard-specification vehicles. Optional extras and accessories will generally increase this figure and reduce the payload capacity accordingly

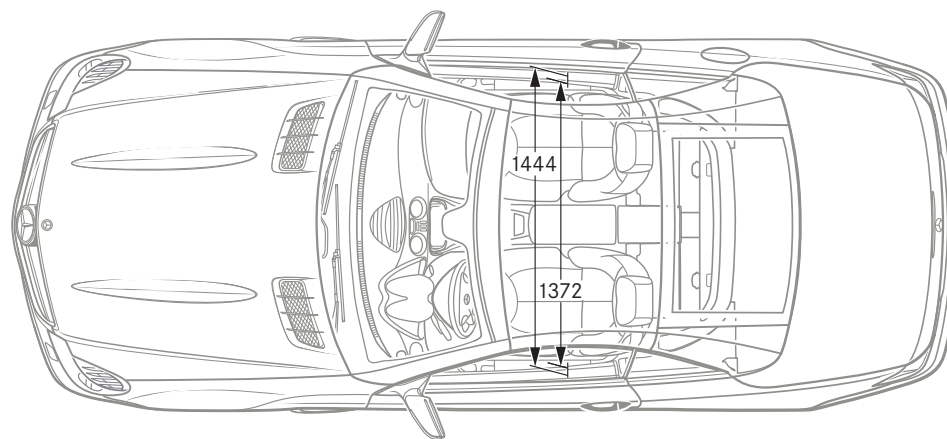
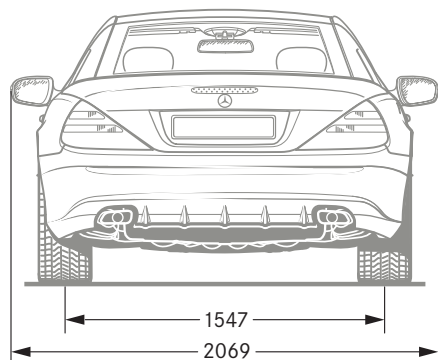
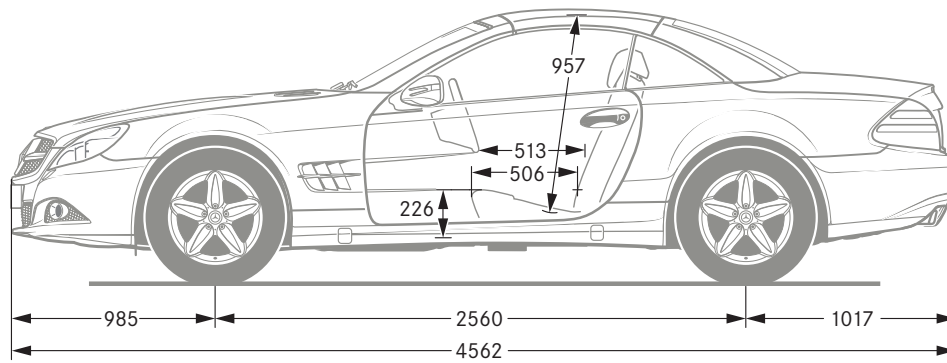
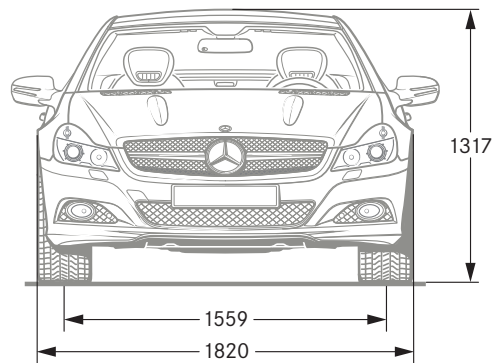



# Anyone opting for a Mercedes buys far more than just a car

Comprehensive service offered by Mercedes-Benz

## Mercedes-Benz Service24h

The feel-good factor, which kicks in when you sit behind the wheel of your new Mercedes for the first time, is further enhanced by the knowledge that Mercedes-Benz Service24h is there for you around the clock – 365 days a year. Experience shows that your Mercedes model is extremely unlikely to suffer a technical problem or breakdown. And even if the unthinkable happens, you can always count on Mercedes-Benz Service24h, wherever you are in Europe. Just call our Service Hotline on 00800 1 777 7777<sup>1</sup> at any time. One of our specialists will take your call and arrange professional assistance for you immediately. By the time you put down the phone, our Service24h team will be getting ready to make their way to you. It will often be possible to sort out the problem at the scene. If this is not the case, however, we will of course arrange for your car to be taken to the nearest Mercedes-Benz workshop.

## MercedesCard

Your ticket to the Mercedes-Benz experience: the quarterly MercedesCard ARGENTUM journal offers you an exclusive selection of exciting events starring the Mercedes-Benz brand. In addition, the Mercedes magazine is packed with gripping and inspiring articles and reports. The MercedesCard has many other functions: as a VISA credit card, it is an accepted form of payment worldwide – with no annual fee if you complete a questionnaire every year. In addition, it offers further benefits to put your mind at ease, such as the Mercedes-Benz insurance package, at no extra charge, and the exclusively compiled MercedesCard insurance package at a preferential rate. For further information about this offer, available exclusively to Mercedes-Benz drivers, visit [www.mercedes-benz.de/mercedescard](http://www.mercedes-benz.de/mercedescard)<sup>2</sup>

## Mercedes-Benz Bank

If you have already chosen your dream car and want to remain financially flexible, the Mercedes-Benz Bank should be your next port of call. We are your one-stop shop for leasing, financing, insurance and service packages. By way of example, our “Private Leasing plus” scheme is a complete package comprising leasing, insurance and a purchase option, while our “Plus3” finance package combines low rates with high flexibility. That’s because, at the end of the contract, you decide yourself whether to keep your car, sell it or return it to us for a guaranteed price. We also offer an attractive range of investment products, including instant-access savings accounts, fixed-interest products and investment funds. For further information, please call us on 01803/32 22 65<sup>3</sup> or visit us at: [www.mercedes-benz-bank.de](http://www.mercedes-benz-bank.de)

<sup>1</sup> Freephone number, mobile-phone rates may vary

<sup>2</sup> Information about the MercedesCard in Austria and Switzerland can be found on the Mercedes-Benz websites for these countries

<sup>3</sup> 9 ct./min from Deutsche Telekom landlines, mobile-phone rates may vary





## Time for another enriching experience

A Mercedes-Benz is most at home on the road. This is the only way to experience the effortlessly superior driving feel that lends every model its inimitable class. Feel the power of the engine as it propels the car forwards. Marvel at the precise steering, designed to really put you in the mood for driving. And experience what true comfort really feels like. The unique feeling of driving a Mercedes cannot be put into words, however. Which is why we'd like to invite you to take a test drive. Your Mercedes-Benz dealer will be happy to make all the necessary arrangements for you. Simply visit [www.mercedes-benz.com](http://www.mercedes-benz.com) to locate the nearest Mercedes-Benz dealer in your country or region. We look forward to seeing you.

The website also offers an interactive tour, enabling you to take a closer look at your desired model. This simulation is the ideal way to acquaint yourself with your dream car. You can view key functions in detail, gain an insight into the car's inner workings or look at the benefits of each model. For further details, visit [www.mercedes-benz.de/owners-manual](http://www.mercedes-benz.de/owners-manual)

Now your mobile phone acts as a gateway to the whole Mercedes-Benz world. In addition to an overview of all passenger car models, there are insights into the entire brand world, not to mention a wealth of entertainment offers and direct links to a range of services at [www.mercedes.mobi](http://www.mercedes.mobi)





Take-back of end-of-life vehicles. Coming full circle. At the end of its long life, you can return your SL-Class to us for environment-friendly disposal in accordance with the EC End-Of-Life Vehicle Directive<sup>1</sup>. But that day lies a long way off.

<sup>1</sup> Applies in accordance with national regulations to vehicles up to 3.5 tonnes gross weight. Mercedes-Benz passenger cars have met the statutory regulations governing the suitability of their design for reuse and recycling for a number of years now. A network of vehicle take-back depots and dismantlers has been established which will process your vehicle in an environment-friendly manner. The ways in which both vehicles and parts can be recovered are subject to ongoing development and improvement. Consequently, the SL-Class will be able to comply with any future increases in the recycling quota within the stipulated time limits. Further information is available at [www.mercedes-benz.de](http://www.mercedes-benz.de) or by calling 00800 1 777 7777

**Please note:** changes may have been made to the product since this brochure went to press (15.08.2008). The manufacturer reserves the right to make changes to the design, form, colour and specification during the delivery period, provided these changes, while taking into account the interests of the vendor, can be deemed reasonable with respect to the purchaser. Where the vendor or the manufacturer uses symbols or numbers to describe an order or the subject of an order, no rights may be derived solely from these. The illustrations may show accessories and items of optional equipment which are not part of standard specification. Colours may differ slightly from those shown in the brochure, owing to the limitations of the printing process. This brochure has been compiled by Daimler AG of Germany and is distributed internationally. It provides a general indication of the range of models, features, optional extras and/or colours available in various countries. Some of the models, features, optional extras and/or colours shown may not be available in your country or may only be available in a different specification. Additionally some models, features, optional extras and/or colours may only be available in combination with others. For current and more specific information in relation to the range of models, features, optional extras and/or colours available in your country, and their pricing, you should contact your nearest authorised Mercedes-Benz Passenger Car Dealer.  
[www.mercedes-benz.com](http://www.mercedes-benz.com)