



This Brochure is prepared by Daimler AG and it predominantly reflects the capabilities and performance of vehicles sold in Europe. Some characteristics, capabilities, performance features and optional extras (e.g. towing systems) may not be available or may not apply in Australia or under Australian conditions. The information in this Brochure is therefore indicative, illustrative and provided only for guidance and should not be relied on. To obtain current and accurate information on a vehicle and any options applicable to Australia, contact your local authorised Mercedes-Benz dealer.

Mercedes-Benz



CLC-Class

Mercedes-Benz

“Our philosophy is very simple. We give our best for people who expect the best.”

Dr Dieter Zetsche

Contents

The CLC-Class	3	My CLC-Class	34
Design	4	Equipment	38
Agility	12	Sports package	38
Petrol engines	16	Equipment packages	42
Transmissions	18	Standard equipment	44
Chassis and steering	20	Optional extras	46
		Light-alloy wheels	48
Safety	22	Genuine accessories	50
Active safety	22		
Passive safety	24	Services	52
Comfort	26	Colours and materials	56
Interior	26	Upholstery, leather and trim elements	56
Seating comfort	28	Paintwork	59
Spaciousness	30		
Sound	32	Technical details	57
		Technical data	57
		Dimensions	58

An exceptional form. For a fast-moving lifestyle

The CLC Sports Coupé

Images on paper can never do justice to the outstanding agility of the Mercedes-Benz sports coupé. But it could soon be right in front of you on the road. Expressive styling

and visible dynamism appeal to the heart and the mind in equal measure. And ensure that the CLC will move you even when you are not moving the CLC.

Expressive design. Intense character

It gives you driving pleasure and ride comfort. It takes away any risk of boredom. It all starts the moment you set eyes on the CLC. The design is a modern take on the classic Mercedes-Benz coupé tradition. Convex and concave surfaces intermingle with dynamic lines to create a compact form and give the body its classic wedge shape - rising dynamically all the way up to the seemingly weightless tail end. Sporty touches here include distinctive two-tone lights and a diffuser-style bumper.

The light-alloy wheels add the finishing touch to the expressive aura of the sports coupé.







Time to surge ahead

The Mercedes-Benz sports coupé radiates energy. Its assuredness and desire to be on the move are immediately apparent. Thanks to the forwards thrust of the distinctive wedge-shaped design and the wide appearance of the chassis. The sportily moulded front apron with air inlets and a large central star in the radiator grille fit perfectly into the overall scheme of things. Plus you can make the CLC Sports Coupé even more expressive by ordering the optional Sports package.









CLC 350



D S OK 9400

Set your expectations high. So that it can do them justice

Five petrol powerplants, including a BlueEFFICIENCY model offering optimum fuel economy, provide the driving force. Exceptional dynamism and agility come courtesy of the Direct-Steer system and the lowered sports suspension. Both form part of the optional Sports package. But the CLC wouldn't be a Mercedes if it didn't combine all of this sportiness with a high standard of comfort. Cue the fast-response transmission, standard-fit sports seats and exclusive interiors, for example.









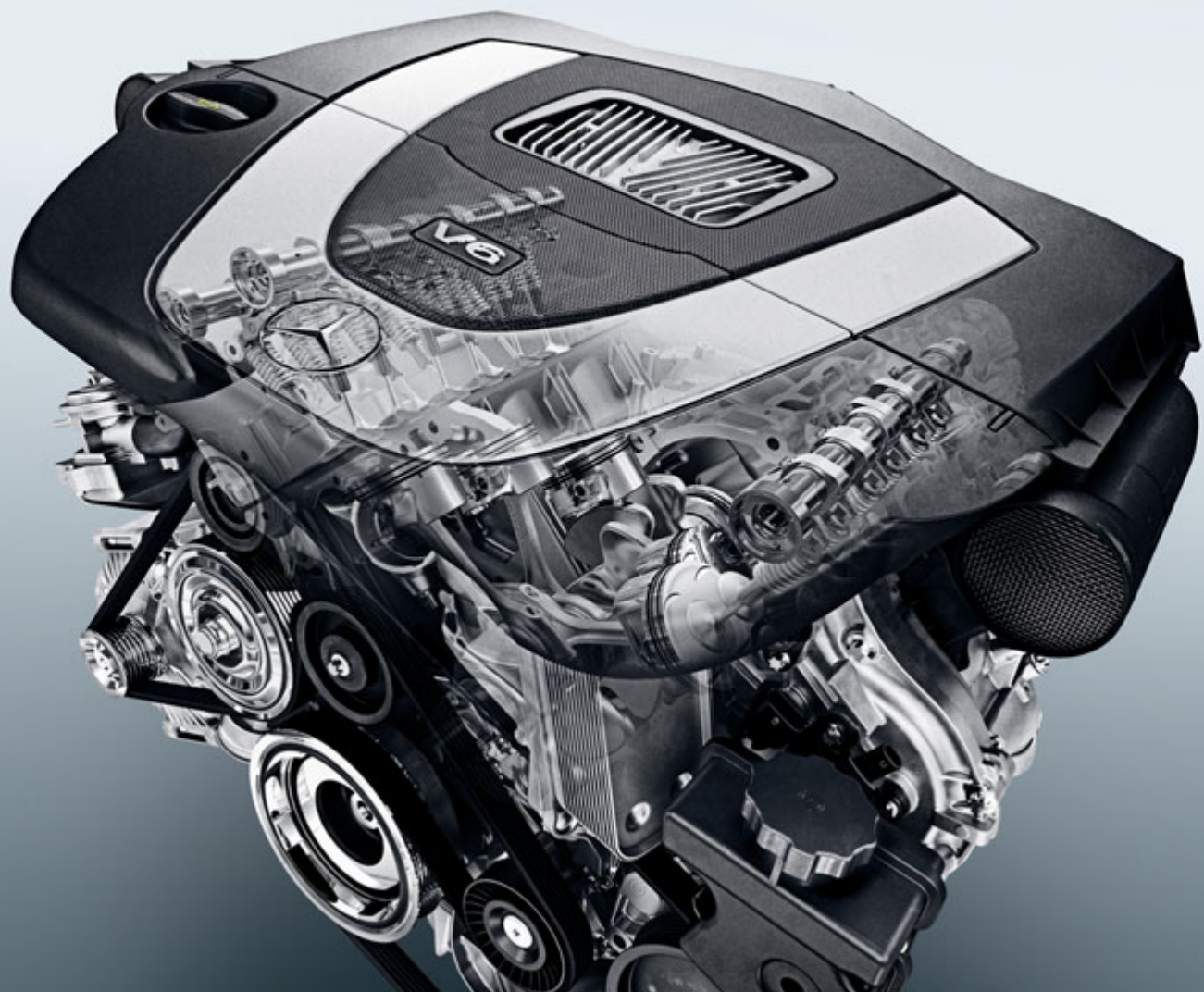

Designed to drive your enthusiasm as well as your car

The petrol engines - maximum torque even at low revs

Keeness to perform and lower emissions are at the heart of the petrol engines for the CLC Sports Coupé. The two 6-cylinder variants deliver their power reserves with an impressive show of strength and spontaneity – the CLC 250 with 150 kW and the CLC 350 with 200 kW. For instance, the CLC 350 takes just 6.3 seconds to sprint from 0 to 100 km/h while the CLC 180 KOMPRESSOR with 105 kW and the CLC 200 KOMPRESSOR with 135 kW are pleasingly economical on fuel consumption yet as

generous as ever with regard to dynamics. All CLC-Class models also come with a current fuel consumption indicator. Our commitment to sustainable mobility and environmental protection is no less legendary. The latest example of this is the 95-kW CLC 160 BlueEFFICIENCY which combines driving pleasure with particularly low fuel consumption and reduced emissions. Classic Mercedes qualities, in fact.

CLC 200 KOMPRESSOR

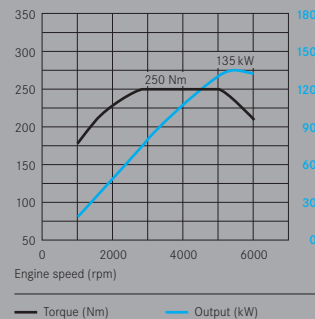

CLC 250

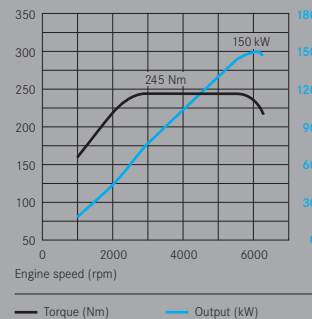

CLC 350

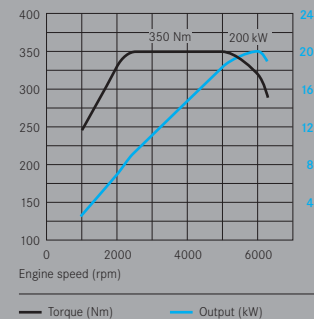

In the BlueEFFICIENCY models numerous fine-tuning measures result in reduced fuel consumption and CO₂ emissions

The best transmissions are the ones that go unnoticed

Fast, precise, exciting: the manual and automatic transmissions

Power is nothing without control. This is why the fast-response transmissions for the CLC are designed to work together with you. The DIRECT CONTROL 6-speed manual transmission sends the power where it belongs: to the road, and that with unerring precision. Fast gear changes are also the order of the day with the optional 5-speed automatic transmission and the 7G-TRONIC

automatic transmission, which is available as an optional extra for the 6-cylinder models. Powerful acceleration in any gear is part of this transmission's genetic make-up - thanks largely to the multiple downshift function. The CLC's shift times are so fast that the route will never seem long enough. Not only does this sound impressive, it also enhances comfort.

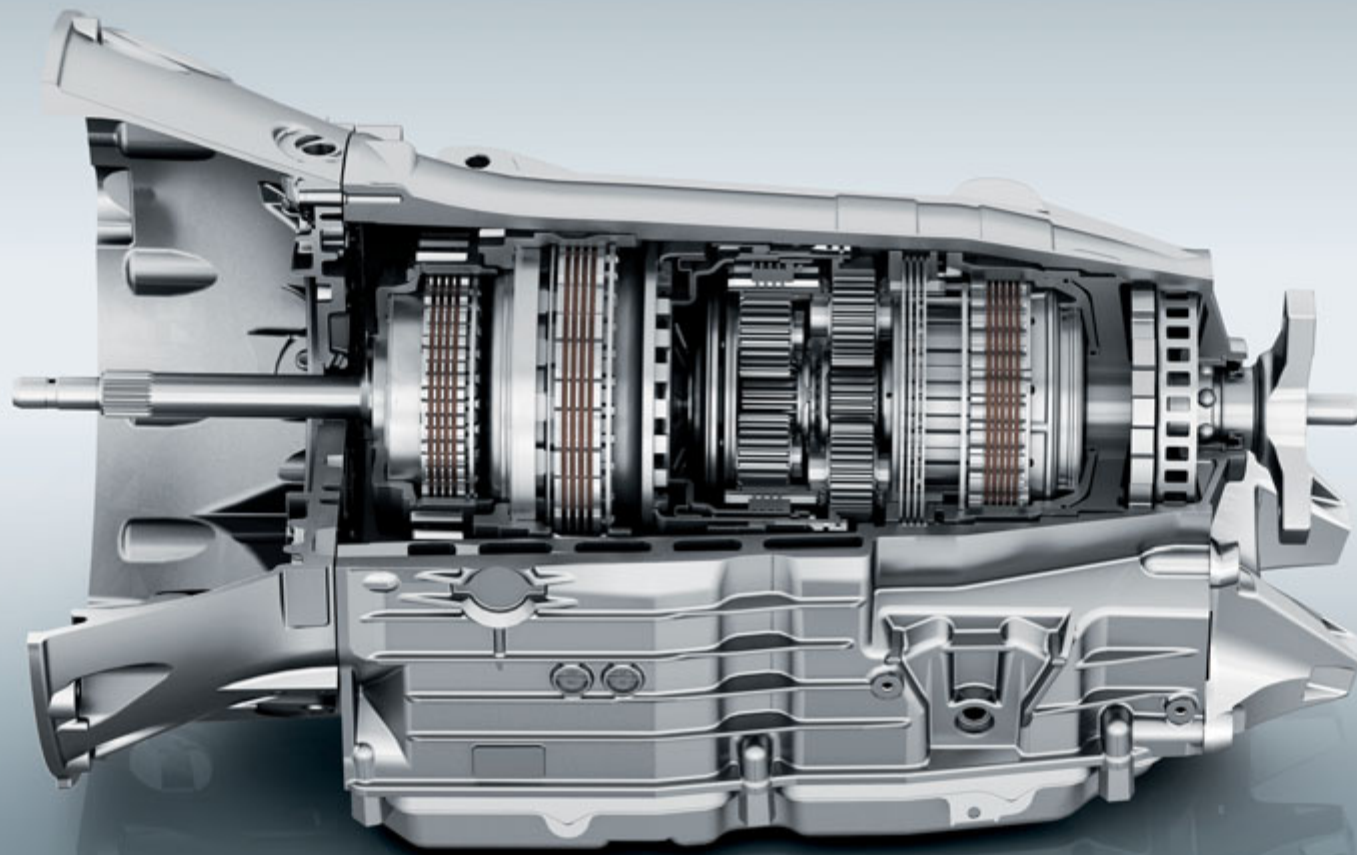

7G-TRONIC: developed with the experience gained from producing more than eleven million automatic transmissions in over 40 years



Only telepathy is more direct

Enticingly sporty, delightfully direct: suspension and steering

You hold the steering wheel with both hands. Each new bend triggers a sense of eager anticipation. With its wide track and taut tuning, the CLC's DIRECT CONTROL suspension sweeps through every bend with sporty flair. The lowered sports suspension, available as an optional extra, does full justice to its name courtesy of some exceptionally dynamic characteristics.

Similarly the Direct-Steer system – part of the optional Sports package – makes you feel a close affinity with the road. It enhances both the agility and the comfort of the CLC by varying its ratio in line with the steering-wheel angle. So even the shortest of trips becomes a pleasure to savour – at every apex.

Maximum excitement. Minimum risk

Active occupant protection for the sports coupé

The CLC is clearly in its element on the road. And to make sure this is where it stays, an impressive array of safety systems helps to prevent accidents before they even get a chance to happen. The Electronic Stability Program ESP® is able to apply the brakes precisely at each individual wheel in the event of over- or under-steer, while Brake Assist (BAS) helps bring the CLC to a stop as quickly as possible when the brakes are applied in an emergency.

Further active-safety components include the anti-lock braking system ABS, the optionally available LED daytime driving lights, and bi-xenon headlamps with a cornering light function, which ensure exceptionally bright illumination of a wide section of the road. Plus the fog lamp on the side of the car in question is activated when the car starts to make the turn. Thus you can see whether the way ahead really is clear in plenty of time.





Hopefully you'll never see a repeat of what we're about to show you

Passive occupant protection for the CLC

Dynamism is at its most stunning when it is under control. This comfortable feeling is built into the CLC. The safety body with its high-strength passenger cell and supporting structure capable of withstanding extremely high loads, along with energy-absorbing deformation zones, forms the heart of the safety concept. Efficient occupant protection is also provided by the airbags. The CLC features front airbags

with two-stage deployment as well as front sidebags and windowbags. All the seats in the sports coupé are equipped with 3-point seat belts. In addition, highly effective belt tensioners and intelligent belt-force limiters contribute to the outstanding level of occupant protection afforded by the CLC Sports Coupé.

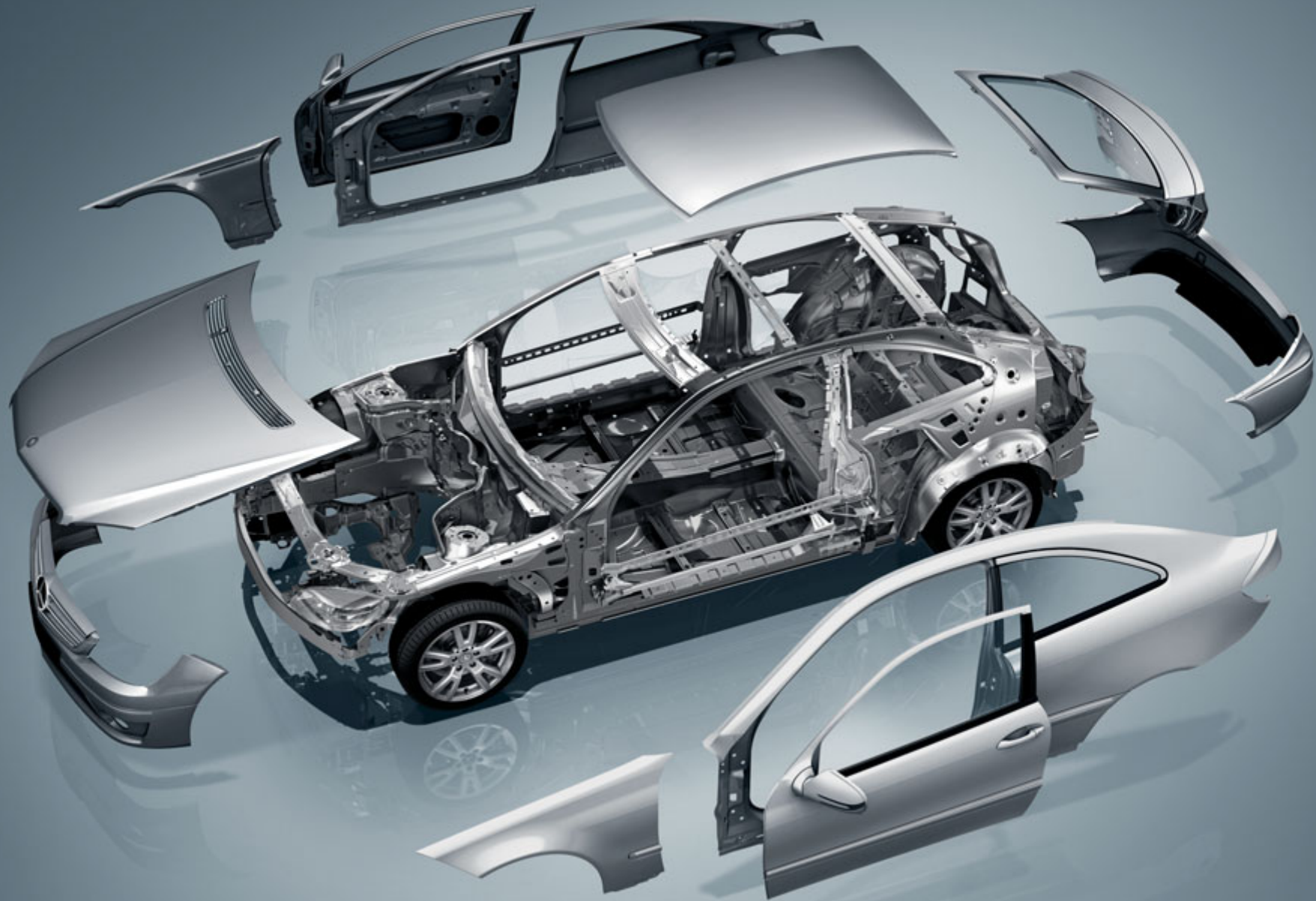





Exclusivity for all five senses. Controllable with the sixth

The cockpit equipment

Opening the driver's door reveals a space that you may not have been expecting. Not just size-wise but, above all, in terms of the harmonious blend of exclusivity and high-quality materials with a sporty design. Features such as the standard-fit automatic climate control THERMATIC add to the enhanced ride comfort.

Impressively dynamic: the appearance of the sporty instrument cluster with distinctive white

needles. Astonishingly intuitive: the controls for key functions. Whether it be the arrangement of the switches or the layout of the instruments, everything is where you would instinctively expect it to be. Without having to chance a second look. Not only is this safer, it also makes driving an even more pleasurable experience. Furthermore, the 3-spoke multifunction steering wheel ensures that even central functions can be controlled quickly and easily.

Sporty and muscular meets suave and sophisticated

Extremely pleasing on the eye: the interior of the sports coupé

Agility and comfort are not always easy bedfellows. But they are when you're ensconced in the standard-fit sports seats. Their good looks are matched by the level of support they offer you whilst driving. They even help you to get into the rear. Simply fold down the backrest – and the EASY-ENTRY system moves the front seats forwards. As well as making life easier, the interior of the CLC is easy on the eye.

Exciting contrasts and high-quality materials – like the optionally available leather appointments in alpaca grey – create an exclusive ambience, while trim elements in brushed aluminium or optionally available black bird's-eye maple wood are combined with black carpet and light seat and door centre panels. So when you next drive to a luxury suite, you'll already feel as if you're in one.







The view outside is as impressive as the one inside

The panoramic sunroof - in its element whatever the weather

Below you, hallmark Mercedes exclusivity. Above you, the open sky. The panoramic sunroof, available as an optional extra for your CLC, opens up a whole new perspective and allows light to flood into the interior, giving a hint of that special open-air feeling you only usually get when driving a cabriolet. That's because, beneath the large panoramic panel spanning the entire roof surface, it's almost like sitting beneath the open sky. You can add to this feeling by moving the front section of the roof rearwards at the touch of

a button - without restricting headroom in the rear in the least.

At the rear, the panoramic sunroof merges into a large tailgate that allows even heavy and bulky items to be loaded with ease. Thanks to a boot capacity of 310 litres (with the luggage cover) or up to 1100 litres (with the rear seat backrests folded down), your CLC has plenty of space for your luggage-carrying requirements. So there's no need to leave anything behind.

Infotainment for the i-generation

Multimedia freedom thanks to Bluetooth®, media interface and Dolby Digital 5.1 surround sound

Welcome to the communications society: for information, communication, navigation and entertainment the CLC offers the latest audio and communications solutions, equipped as standard with user-friendly colour displays and a Bluetooth® interface that connects the mobile phone wirelessly with the hands-free feature. Simply intuitively functional.



Bluetooth® interface display

To begin with, there is the optional Audio 20 CD with an integrated CD player or optionally with an integrated CD changer for 6 CDs, MP3 capability, 12.7-cm display and Aux-in connection in the glove compartment.

Over and above these functions, the Audio 50 APS system offers you a convenient DVD arrow-based navigation function with junction zoom and Traffic Message Channel (TMC).

Completing the line-up, the COMAND APS multimedia system impresses with its hard-disc navigation, Birdview and high-resolution 16.5-cm display. Further components of the system are: the intuitive voice-operated control system LINGUATRONIC, 4-GB memory for audio files (MUSIC REGISTER) and a socket for SD memory cards.

With the optional media interface, for the first time it is possible to integrate an iPod®, USB stick or other external audio devices into the CLC operating system. This way, the track titles are shown in the display and can be controlled with the buttons of the multifunction steering wheel (available from Audio 20 CD with a 6-disc CD changer upwards).

If from now on you get into the car to listen to music, too, this could be because of your new CLC. The sonorous Harman Kardon® Logic 7® surround sound system will provide just the right sound experience, with its 450-Watt output and perfectly adjusted surround sound in Dolby Digital 5.1 and DTS technology.



RADIO DISC

NAVI TEL

SYS

KK PPX

ON

01:59 TA

Navi Audio. Tel Video System

1 No one

01:51

iPod L 70&80

Alicia Keys

Media Interface Music Medium Sound

1 2 3

00 ABC DEF

4 5 6

GHI JKL MNO

7 8 9

PQRS TUV WXYZ

* + # ↕

← C

OK

AUTO OFF

WIND FAN

Bluetooth





My CLC-Class





Sport de luxe

The Sports package for your CLC

A special impression requires a special expression. Something the CLC derives from the optional Sports package. Its body hugs the road more closely, thanks to the sports suspension, while the innovative variable-ratio Direct-Steer system is also a part of the Sports package. You will feel it in the form of even more direct handling and enhanced agility.

You can tell the sporty tailoring for your CLC above all by the 5-twin-spoke light-alloy wheels and the 225/40 R 18 tyres at the front and 245/35 R 18 tyres at the rear. Darkened projection-beam headlamps and a radiator grille with black louvres and chrome highlights underscore the car's expressiveness.



The air intake grille with its atlas grey mesh design



The sound-optimised exhaust system





The 3-spoke leather sports steering wheel continues the dynamic theme of the Sports package in the interior. Dark brushed aluminium trim elements and an instrument cluster with red needles and a chequered-flag design set the tone. When the key is inserted and turned in the ignition, the speedometer and rev counter spring to life. The needles swiftly abandon their 6 o'clock position and sweep the complete dial, to return to the starting position after a fraction of a second. This is just a selection of the benefits. Others include the standard seats in ARTICO man-made leather with a perforated seat surface. For the even more discerning, leather appointments in cognac brown are available as an exclusive optional extra in conjunction with the Sports package. After all, uniqueness is the norm for the CLC with the Sports package.



The easy-grip leather sports steering wheel



The studded stainless-steel sports pedals

Luxury is also about personal preference

For discerning tastes: Exclusive package and Comfort package

The upgraded appointments in the Exclusive package are designed for those who feel that even everyday luxury is too ordinary. This package enables you to further personalise the CLC with a wide range of options, for example the memory function for the driver's and front passenger seat settings or the luxury automatic climate control THERMOTRONIC.



The electric seat adjustment with memory function

Those who spend a lot of time on the road will feel perfectly at home in the CLC with the Comfort package. Useful features of this equipment package include a rain sensor, electrically folding exterior mirrors and an automatic dimming function for the driver as well as a tyre pressure loss warning system, all of which means that the focus is firmly on your comfort and convenience.



Luxury automatic climate control THERMOTRONIC



Tyre pressure loss warning system



Rain sensor



One of the electrically adjustable exterior mirrors



The exterior mirror, electrically folded

STANDARD EQUIPMENT (Selection)

3-point seat belts, height-adjustable in front; with automatic height adjustment in rear

Airbags and sidebags for driver and front passenger, plus windowbags for driver, front passenger and rear passengers

ASSYST service interval indicator

Automatic climate control THERMATIC with separate temperature control for driver and front passenger, dust filter and activated charcoal filter and air recirculation switch with convenience function and ventilation outlets for the rear

Belt tensioners with belt force limiters front and rear

Brake Assist (BAS)

Central locking with interior switch and crash sensor

Chrome package: chrome highlights for bumpers and rub strips

Clear-lens headlamps, indicators, tail lights and brake lights with high-gloss effect

Cruise control with SPEEDTRONIC variable speed limiter

Designer key (ignition key with chrome highlight)

DIRECT CONTROL 6-speed manual transmission

DIRECT CONTROL power steering with safety steering column

DIRECT CONTROL suspension

Door sill panels with "Mercedes-Benz" lettering

EASY-ENTRY system for rear passengers

Electronic Stability Program ESP®

Exterior mirror with integrated LED indicator

Fabric/ARTICO man-made leather upholstery

First-aid kit



Wide coupé radiator grille with chrome highlights



The two-tone tail lights and third brake light



Exterior mirror with integrated LED indicator

STANDARD EQUIPMENT (Selection)

Front armrest with stowage compartment and cup holder

Front fog lamps

Front sports seats with reinforced lateral support

Headlamp Assist

Headlamp range adjustment

Heated rear window

Immobiliser with ELCODE locking system and infrared remote control

ISOFIX child seat attachment points in rear

Outside temperature display

Power windows (2) with one-touch control and obstruction sensor

Seat occupancy sensor for front passenger seat

Side-impact protection

Steering column manually adjustable for height and reach

Sun visor with vanity mirror

Three-spoke multifunction steering wheel

Through-loading feature, rear bench seat folds fully or with 1/3 : 2/3 split

Tinted glass

TIREFIT tyre sealant with electric pump

Trim elements in light, brushed aluminium

Trip computer in the multifunction display

Warning buzzer that sounds if the vehicle lights are left on and the parking brake is applied

Windscreen wiper system with one-touch control



Automatic climate control with aluminium trim elements



Headlamp Assist



Designer key

OPTIONAL EXTRAS (Selection)	CLC 160 BlueEFFICIENCY	CLC 180 KOMPRESSOR	CLC 200 KOMPRESSOR	CLC 250	CLC 350
7G-TRONIC automatic transmission	-	-	-	●	●
Bi-xenon headlamps with dynamic range control and cornering light function	●	●	●	●	●
COMAND APS, multimedia system	●	●	●	●	●
Harman Kardon® Logic 7® surround sound system	●	●	●	●	●
Heat-insulating dark-tinted glass for rear side windows and rear window	●	●	●	●	●
Leather steering wheel and leather-covered shift lever	●	●	●	●	●
LED daytime driving lights	●	●	●	●	●
Panoramic sliding sunroof and illuminated sun visor	●	●	●	●	●
Sidebags in rear	●	●	●	●	●
Sports suspension	●	●	●	●	●
Trim elements in high-gloss black bird's-eye maple wood	●	●	●	●	●

● Optional extra ○ Standard - Not available



Heat-insulating dark-tinted glass at the rear



The panoramic sliding sunroof



The bi-xenon headlamps with a cornering light function

EQUIPMENT PACKAGES (Selection)	CLC 160 BlueEFFICIENCY	CLC 180 KOMPRESSOR	CLC 200 KOMPRESSOR	CLC 250	CLC 350
Comfort package: rain sensor, interior mirror and driver's-side exterior mirror with automatic dimming function, exterior mirrors left and right electrically folding, tyre pressure loss warning system	●	●	●	●	●
Exclusive package: memory function for electrical adjustment of front seats, steering column and exterior mirrors as well as luxury automatic climate control THERMOTRONIC	●	●	●	●	●
Sports package: including Direct-Steer system, sports suspension, 5-twin-spoke light-alloy wheels, ARTICO man-made leather upholstery in a choice of 2 variants, 3-spoke leather sports steering wheel with multifunction capability	●	●	●	●	●

● Optional extra

○ Standard

– Not available



The Audio 50 APS with DVD navigation system



The voice-operated control system LINGUATRONIC



PARKTRONIC with LED display

Create an even greater impression – the wheels for your CLC

You can give your CLC a really personal touch with our range of light-alloy wheels. There is a wide selection of sporty designs to choose from, depending on the engine.



Optional extra: 5-spoke light-alloy wheel with 205/55 R 16 tyres (standard on CLC 250)



Optional extra: 10-spoke light-alloy wheel with 195/60 R 16 tyres



Optional extra: 5-twin-spoke light-alloy wheel with 225/45 R 17 tyres (standard on CLC 350)



Optional extra: 5-twin-spoke light-alloy wheel with 225/45 R 17 tyres at the front and 245/40 R 17 tyres at the rear



Optional extra: 6-spoke light-alloy wheel with 225/45 R 17 tyres at the front and 245/40 R 17 tyres at the rear



Standard for Sports package: 5-twin-spoke light-alloy wheel with 225/40 R 18 tyres at the front and 245/35 R 18 tyres at the rear



Optional extra: AMG 5-spoke light-alloy wheel with 225/40 R 18 tyres at the front and 245/35 R 18 tyres at the rear



Accessory wheel ex factory: incenio 5-triple-spoke "Korsunia" light-alloy wheel with 225/40 R 18 tyres at the front and 245/35 R 18 tyres at the rear



Accessory wheel: incenio 5-spoke "Almuredin" light-alloy wheel, painted titanium silver with high-sheen finish, with 225/40 R 18 tyres at the front and 245/35 R 18 tyres at the rear

Whatever light-alloy wheels you go for: all of them accentuate the sports coupé's expressive appeal.



An ideal starting point – genuine accessories

As well as being styled for maximum appeal, each and every detail of a Mercedes is also designed for maximum practicality. Take the handy accessories such as the aerodynamic roof box or the swivelling ski and snowboard rack, for instance. Not only does your equipment stay safe and well protected until you arrive at your destination, it is also easy to load and unload.



New Alustyle ski and snowboard rack

Furthermore, practical luggage nets allow you to stow loose items such as toys, footballs or running shoes out of harm's way whilst you are driving. So there's a safe place for everything on board the CLC. And there is one other thing you can be sure of: only genuine Mercedes accessories are designed to fit your Mercedes perfectly.



Luggage nets for the boot floor and the boot sill



Anyone opting for a Mercedes buys far more than just a car

Mercedes-Benz Museum. More than 120 years of automotive history in one place – this is what awaits you at the Mercedes-Benz Museum in Stuttgart. Experience the unique excitement, and embark upon a thrilling journey through time. Housed inside an architecturally impressive building, over 1500 exhibits on nine levels give you an insight into the unique tradition and powers of innovation of the Mercedes-Benz brand. See the world's first two automobiles in the shape of the Benz Patent-Motorwagen (motor car) and the Daimler motorised carriage – both from the year 1886. Two linked circuits take you from the beginnings of the automobile, past a series of unforgettable classics, through more than 100 years of motor racing history and, finally, on to a glimpse of what the future holds – in an area covering a total of 16,500 square metres. Enjoy the unique brand experience. We look forward to your visit. Further details can be found at www.mercedes-benz.com/museum

MercedesCard. The card is your ticket to the Mercedes-Benz experience: four times a year, we will send you exciting details of a selected range of events and services, which we have put together exclusively for you. Then there is the Mercedes magazine with its fascinating reports and articles. But the MercedesCard also has many other uses: as a VISA credit card, it is an internationally accepted means of payment. Plus it offers further benefits to provide you with peace of mind, such as the exclusively compiled MercedesCard insurance package at a preferential price. You can also gain free entry to the Mercedes-Benz Museum simply by showing your VISA MercedesCard. Further details can be found at www.mercedes-benz.de/mercedescard¹

Mercedes-Benz Financial Services. Mercedes-Benz stands for quality, innovation and safety – and the same applies to Mercedes-Benz Financial Services. Our innovative leasing and financing products are tailored to your financial needs and means, making it easy for you to secure the keys to your dream car. Once you are on the road, our insurance products offer you just the right level of protection on every trip. Finally, our service products ensure that your car is always in tip-top condition whilst keeping costs transparent and easily manageable. For a detailed quotation, please contact your Mercedes-Benz dealer, who will be glad to go through the latest financial offers and terms together with you.

¹ Information about the MercedesCard in Austria and Switzerland can be found on the Mercedes-Benz websites for these countries



Mercedes-Benz mobility. Your new car comes with the assurance of carefree driving, but if you should ever need help Mercedes-Benz Service24h is there for you. Just call the freephone service hotline on 00800 1 777 7777². The newly integrated telematics service Mercedes-Benz Contact³ is even more customer-friendly: a touch of a button is all it takes to contact the Mercedes-Benz customer centre. If you wish, the relevant vehicle and position-related data can be transmitted at the same time, ensuring the shortest possible reaction time and rapid assistance. Also standard with your new car at no extra charge is the Mercedes-Benz Mobilo⁴ mobility package. Whether you have lost your key, have had a breakdown which cannot be repaired immediately or if the vehicle is damaged due to an accident or vandalism, Mobilo ensures that you still reach your destination – anywhere in Europe. Whatever your problem, one thing is certain: you will soon be able to resume your journey.

Service packages. Vehicle-specific services allow you to put together an individual package for your Mercedes, including long-term protection against unforeseeable repair costs and high-quality servicing with genuine Mercedes-Benz parts. You can also count on the extensive network of Mercedes-Benz workshops, where you will receive the usual high standard of service for your Mercedes at a predictable, fixed price. Please ask your Mercedes-Benz dealer for further details.

Test drive. The unique feeling of driving a Mercedes cannot be put into words. Which is why we'd like to invite you to take a test drive. Simply visit www.mercedes-benz.com to locate the nearest Mercedes-Benz dealer in your country or region. We look forward to seeing you.

Interactive Owner's Manual. The website also offers an interactive tour, enabling you to take a closer look at your desired model. This simulation is the ideal way to acquaint yourself with your dream car. You can view key functions in detail, gain an insight into the car's inner workings or look at the benefits of each model. For further details, go to: www.mercedes-benz.de/owners-manual

Mobile internet. Now you can access the entire world of Mercedes-Benz from your mobile phone. As well as an overview of all the passenger car models, there are insights into the entire brand world along with a wealth of entertainment offers and direct links to our range of services at www.mercedes.mobi

² Mobile-phone rates vary according to service provider. Alternative number: +49 69 95 30 72 77

³ Only in conjunction with a factory-fitted radio and switched-on mobile phone. For the cost of a call to the landline network

⁴ When the warranty has expired Mobilo can be extended by another year for a maximum of 30 years, provided that regular maintenance is carried out by your Mercedes-Benz service partner

ARTICO MAN-MADE LEATHER/FABRIC

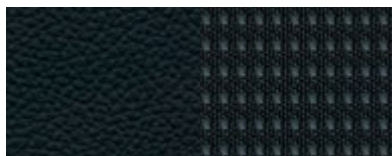

721 black/black

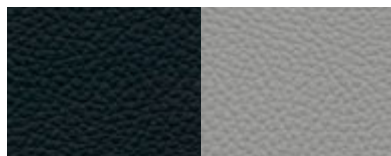
ARTICO MAN-MADE LEATHER¹171 black²

LEATHER

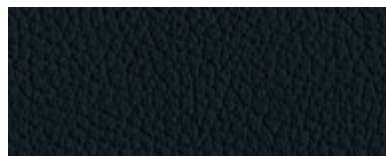

241 black

TRIM ELEMENTS



Aluminium with light longitudinal grain

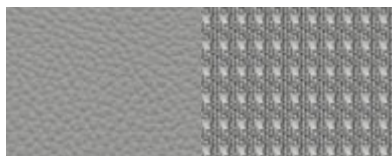

728 alpaca grey/alpaca grey

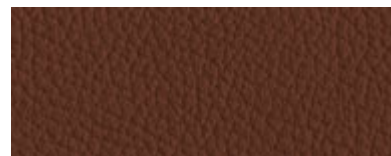
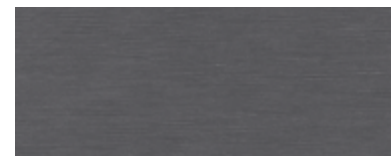
178 alpaca grey³244 cognac brown¹Aluminium with dark longitudinal grain¹

248 alpaca grey



High-gloss black bird's-eye maple wood

¹ Only available for Sports package² Centre console, door lining, rear side trim and carpeting in black, seats in alpaca grey/black³ Centre console, door lining, rear side trim in alpaca grey, carpeting in black, seats in alpaca grey/black

	CLC 160 BlueEFFICIENCY	CLC 180 KOMPRESSOR	CLC 200 KOMPRESSOR	CLC 250	CLC 350
No. of cylinders/arrangement	4/in-line	4/in-line	4/in-line	6/V	6/V
Total displacement (cc)	1597	1796	1796	2496	3498
Rated output ¹ (kW at rpm)	95/5000	105/5200	135/5500	150/6100	200/6000
Rated torque ¹ (Nm at rpm)	220/2500–3800	220/2500–4200	250/2800–5000	245/2900–5500	350/2400–5000
Compression	9.3	9.3	8.5	11.4	10.7
Acceleration 0–100 km/h (s)	11.2	9.7	8.6	8.4	6.3
(automatic transmission)	(11.5)	(9.9)	(8.7)	(8.6)	(6.3)
Top speed approx. (km/h)	210	220	235	240	250 ⁴
(automatic transmission)	(206)	(215)	(231)	(234)	(250 ⁴)
Tyre size	front	205/55 R 16	205/55 R 16	205/55 R 16	225/45 R 17
	rear	205/55 R 16	205/55 R 16	205/55 R 16	225/45 R 17
Fuel	Premium petrol	Premium petrol	Premium petrol	Premium petrol	Premium petrol
Fuel consumption ² (l/100 km)					
urban (automatic transmission)	8.7–9.2 (10.5–10.9)	9.3–10.0 (10.6–11.4)	9.7–10.2 (10.9–11.5)	13.6–13.9 (13.5–13.7)	14.0–14.3 (14.2–14.5)
extra-urban (automatic transmission)	5.4–6.0 (5.8–6.3)	5.4–6.0 (5.7–6.4)	5.7–6.3 (5.9–6.6)	6.8–7.2 (6.9–7.4)	7.1–7.4 (7.4–7.8)
combined (automatic transmission)	6.6–7.2 (7.5–8.0)	6.8–7.5 (7.5–8.2)	7.2–7.7 (7.7–8.4)	9.4–9.7 (9.3–9.7)	9.7–10.0 (9.9–10.2)
CO ₂ emissions combined ² (g/km)	154–168	159–175	167–180	218–225	227–234
(automatic transmission)	(175–187)	(175–191)	(181–196)	(217–226)	(232–239)
EU emission standard	EU5	EU5	EU5	EU5	EU5
Tank capacity (l), incl. reserve, approx.	62/8	62/8	62/8	62/8	62/8
Boot capacity (l)	310	310	310	310	310
Turning circle diameter (m)	10.77	10.77	10.77	10.77	10.77
Kerb weight ³ (kg)	1470	1475	1480	1525	1550
(automatic transmission)	(1490)	(1495)	(1500)	(1545)	(1570)
Permissible gross vehicle weight (kg)	1940	1945	1950	1995	2020
(automatic transmission)	(1940)	(1945)	(1950)	(1995)	(2020)

¹ Figures according to Directive 80/1269/EEC in the currently applicable version

² The figures shown were obtained in accordance with the prescribed measuring process (Directive 80/1268/EEC in the currently applicable version). The figures are not based on an individual model and do not constitute part of the product offer; they are provided solely for purposes of comparison between different vehicle models

³ Figures according to Directive 92/21/EC, version 95/48/EC (kerb weight with fuel tank 90% full, driver, 68 kg, and luggage, 7 kg) for standard-specification vehicles. Optional extras and accessories will generally increase this figure and reduce the payload capacity accordingly

⁴ Electronically governed

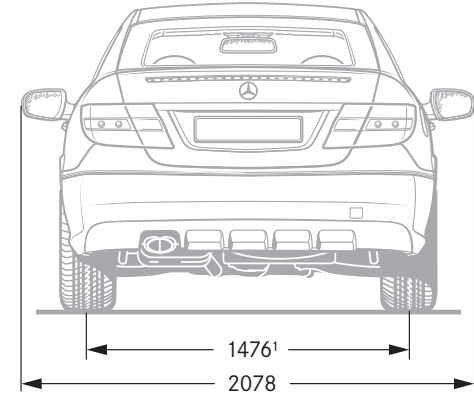
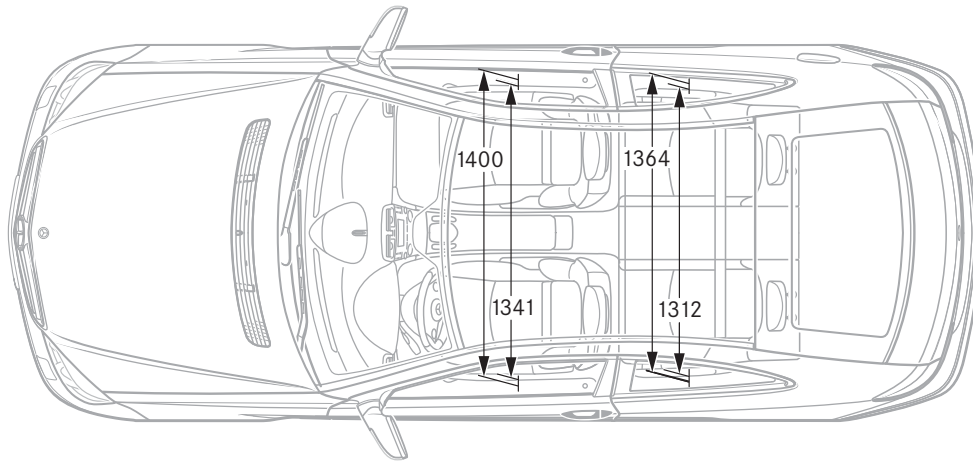
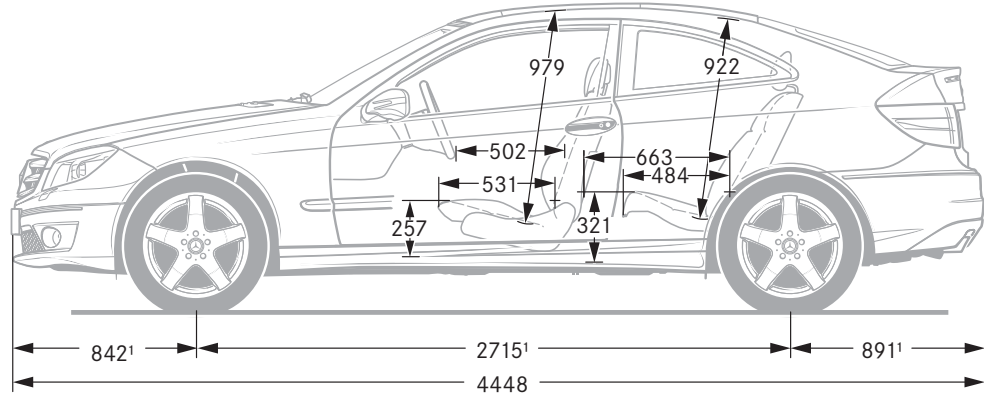
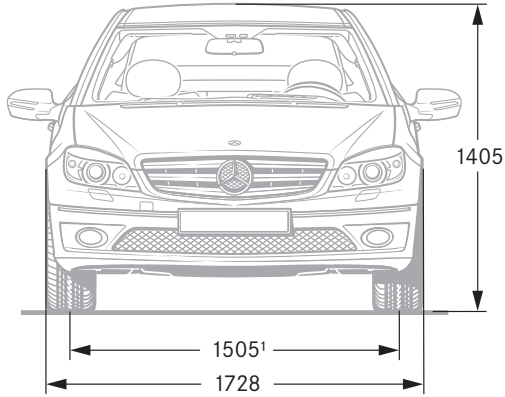

All measurements in millimetres. The dimensions shown are mean values and apply to standard-specification, unladen vehicles

¹ Carrying 3 people, each weighing 68 kg

NON-METALLIC PAINTS¹



040 black



590 fire opal



650 calcite white

METALLIC PAINTS²



197 obsidian black



230 indigolite blue



497 cuprite brown



755 tenorite grey



775 iridium silver

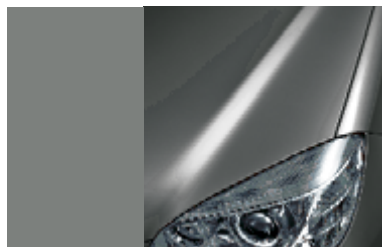

792 palladium silver

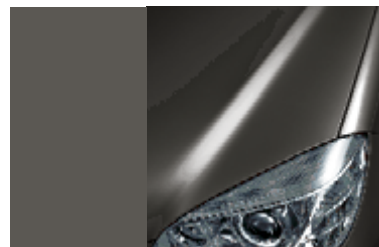

963 indium grey

¹ Standard equipment

² Optional extra

Take-back of end-of-life vehicles. Coming full circle. At the end of its long life, you can return your CLC-Class to us for environment-friendly disposal in accordance with the EC End-Of-Life Vehicle Directive¹. But that day lies a long way off.

¹ Applies in accordance with national regulations to vehicles up to 3.5 tonnes gross weight. Mercedes-Benz passenger cars have met the statutory regulations governing the suitability of their design for reuse and recycling for a number of years now. A network of vehicle take-back depots and dismantlers has been established which will process your vehicle in an environment-friendly manner. The ways in which both vehicles and parts can be recovered are subject to ongoing development and improvement. Consequently, the CLC-Class will be able to comply with any future increases in the recycling quota within the stipulated time limits. For further information please call 00800 1 777 7777.

Please note: changes may have been made to the product since this brochure went to press (17.02.2010). The manufacturer reserves the right to make changes to the design, form, colour and specification during the delivery period, provided these changes, while taking into account the interests of the vendor, can be deemed reasonable with respect to the purchaser. Where the vendor or the manufacturer uses symbols or numbers to describe an order or the subject of an order, no rights may be derived solely from these. The illustrations may show accessories and items of optional equipment which are not part of standard specification. Colours may differ slightly from those shown in the brochure, owing to the limitations of the printing process. This brochure is distributed internationally. It provides a general indication of the range of models, features, optional extras and/or colours available in various countries. Some of the models, features, optional extras and/or colours shown may not be available in your country or may only be available in a different specification. Additionally some models, features, optional extras and/or colours may only be available in combination with others. For current and more specific information in relation to the range of models, features, optional extras and/or colours available in your country, and their pricing, you should contact your nearest authorised Mercedes-Benz Passenger Car Dealer. www.mercedes-benz.com