

# HiLux

Unbreakable.



**TOYOTA**



[toyota.com.au](http://toyota.com.au)



*Oh what a feeling!*

# Getting the job done. The story of Toyota Commercial Vehicles.



*Getting the job done. That's been our motto for more than half a century. No matter the terrain, no matter the weather, no matter the load, our engineers' pursuit of perfection will ensure we meet our mantra. At Toyota, we know that every job matters and we know that the quality, durability and reliability we promise is crucial.*

## **There through thick and thin.**

We've done it tough since day one. Back in 1958, on the slopes of the Snowies, our very first LandCruiser was used as a tool for thousands of Snowy Mountain Hydro Scheme workers. It got them to their worksite, and home again, every day. Their back-breaking work on unforgiving and unpredictable land was shouldered by this unbreakable workhorse. No wonder it's known as the 4WD that built Australia.

Now, more than fifty years on, we're still at work building the nation. Our commercial fleet is still getting the job done everywhere and more Australians rely on us than ever before. From cattle drovers to camel catches, boaties to brickies, our quality, durability and reliability is expected.

## **And still there's work to be done.**

We boast the toughest, strongest, and smartest work vehicles ever made, because we've been there before. We work to bring you the best vehicles to tackle the toughest terrain on earth, and we'll continue to evolve and strive to make each Toyota better than the last.

# HiLux

## Hard as nails. Sharp as a tack.



4x2 SR Extra-Cab Pick-up Turbo-diesel in Lustre.  
Front cover: 4x4 SR5 Double-Cab Pick-up Turbo-diesel in Metal Storm.

There's a whole bunch of reasons why HiLux is Australia's favourite Action Utility Vehicle. Across the nation you'll see it getting its teeth into all kinds of hard yakka, both on and off-road. With a reputation for being unbreakable, you can push it to the limit, but it keeps coming back for more.

HiLux is the working man's workhorse, but it also knows how to let off steam. The VVT-i petrol or gutsy turbo-diesel engines pack a real punch without compromising on reliability or efficiency. And with plenty of space and comfort inside, the whole time your HiLux is working-up a sweat, you can just kick-back and relax. It's the sidekick every hard-working bloke deserves.

Sure, it's a beast. But HiLux never forgets who's boss. With its responsive handling, you're always firmly in control – even in the toughest conditions. And with its array of intelligent technologies, you can be sure that no matter what you get yourself into, you will always be able to get out.

One of the toughest things about the HiLux is picking one. With thirty-five variations to choose from, including both 4x2 and 4x4 configurations, three different engines including a 2.7 litre 4 cylinder, 4.0 litre V6 petrol engine and the turbocharged 3.0 litre diesel engine featuring Electronic Direct Injection. Along with a choice of cab variants and eight different colours to choose from, it's quite the challenge. With so many options, one thing's for sure, there's a HiLux that's perfect for you.



## Unleash a beast.

When it's all said and done, it's what's on the inside that counts. That's why HiLux offers you three powerful engines to choose from. So whether you're navigating the urban jungle, or scrambling over challenging terrain, there's a HiLux ready to take it on with you.

### Real power's within reach

2.7L 4-cylinder with VVT-i

*Available on WorkMate models*

This gutsy 2.7 litre petrol engine with 116kW of power makes outstanding performance available at an affordable price. With VVT-i technology seeing it punch above its weight, this DOHC 4-cylinder delivers smooth power all the way up the rev range. And with advanced technologies that improve fuel efficiency and reduce emissions, you can cut loose with a clearer conscience.



2.7L 4-cylinder with VVT-i



4.0L V6 with VVT-i



3.0L Turbo-diesel



4x4 SR Double-Cab Pick-up V6 with option pack in Sterling Silver.

### **The V. Special V6**

4.0L V6 with VVT-i

*Available on SR & SR5 models*

The high-performance, 4.0 litre V6 is bristling with quad cam-enhanced muscle – delivering an impressive 175kW of power at 5,200rpm. But it doesn't just perform at the top end, it's big on torque too – with a massive 376Nm of torque at 3800rpm in the automatic version – so you're always big on action.

With the technological advancement of Toyota's cutting edge Variable Valve Timing with intelligence (VVT-i), for a smoother cleaner running ride, HiLux is hard on the road, but gentle on the driver. And with sensible fuel economy, you'll go longer between fill-ups, a lifesaver in some of Australia's more remote locations.

### **Strong strides, soft footprint**

3.0L Turbo-diesel

*Available on all models*

Pack an impressive punch, with impressively low emissions. The 3.0 litre Electronic Direct Injection turbo-diesel engine gives you a hefty 126kW of power at 3600rpm, matched with the significant pulling power of 343Nm of torque at 3400rpm – whilst complying with EURO IV emission standards.

Using 'common rail' fuel injection technology to create a smart balance of power output and reliability, it's got a four valve cylinder head, centrally located injector and in-piston combustion chamber for optimum performance.

Despite all the power, Toyota engineers have worked hard to keep the noise down, with twin counter-rotating balance shafts reducing Noise Vibration & Harshness (NVH). Driveability is further improved with electronic engine management and 'drive-by-wire' throttle. In a nutshell, it'll give you a world of force, without being too rough on the planet.

# Making the unforgettable, unbreakable.

A lot of work goes into making HiLux not just look effortlessly good, but unbreakable. With a terrain and climate as diverse, and at times unforgiving, as Australia's, you need a vehicle that can cope with extremes. From tight corners in city streets to vast open deserts, HiLux can handle anything your location throws at it.

With a clever mix of high tensile and anti-corrosion sheet steel, the body is as tough as they come, with a rigid design that takes the strain, whatever you load it with. It's also built to go the distance, with less wear and tear meaning less maintenance in the long-run, delivering you great value for money.

We've spent years getting the science of body structure right, making sure our vehicles can take the maximum load possible while minimising the impact on performance and efficiency. Our engineers are dedicated to creating, developing and improving even the tiniest detail, to create a reliable performance experience we're proud to put our name to. It's a lot to take in. But all you really need to know is that the HiLux is designed to be one tough nut.

## **A heavy-duty heavy-weight.**

Depending on your chosen configuration, HiLux can carry up to 1.3 tonnes<sup>1</sup>. It's all down to the build. Thanks to the tough chassis with smart reinforced cross-channels, weight is distributed more evenly – so you can fearlessly pile on the load without creating a similar-sized dent in performance.

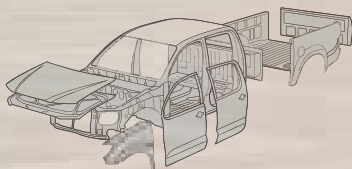

Anti-corrosion steel sheeting



Chassis

<sup>1</sup> Kerb, tare and payload weights are nominal and will vary depending on options and accessories and tray/body type.



WorkMate 4x2 Single-Cab Cab-Chassis Turbo-diesel shown accessorised with after-sale dealer fitted General Purpose Aluminum tray



Front, Side and Curtain Shield Airbags shown on 4x4 SR5 Double-Cab A/T

**It's unbreakable,  
because you're not.**

With its hard-earned reputation for toughness, it won't surprise you to learn that HiLux is big on safety. With an energy-absorbing front chassis structure and strong Safe-T-Cell, it takes impacts from all angles on the chin.

But while it's big on brawn, it's got brains too. To help prevent collisions, ABS (Anti-skid Braking System) is standard on all models, while all SR5 Double-Cab 4x4 models have VSC (Vehicle Stability Control). VSC helps ensure stability by automatically adjusting engine output and the braking force of each wheel when the vehicle experiences over steer or under steer during cornering. Whilst TRC (Traction Control) controls the wheel spin when starting or accelerating on slippery or uneven road surfaces.



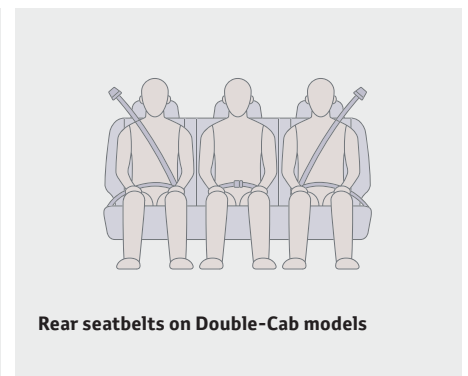
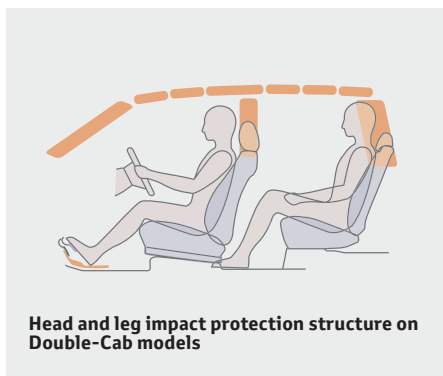
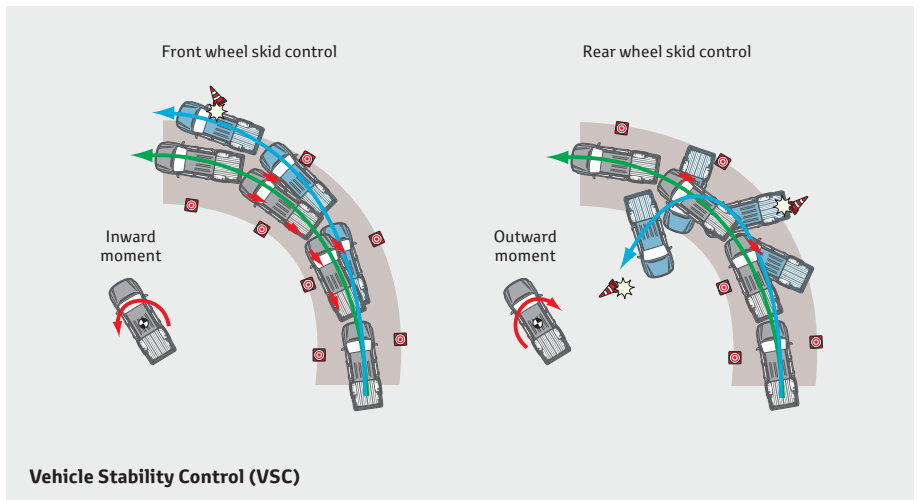
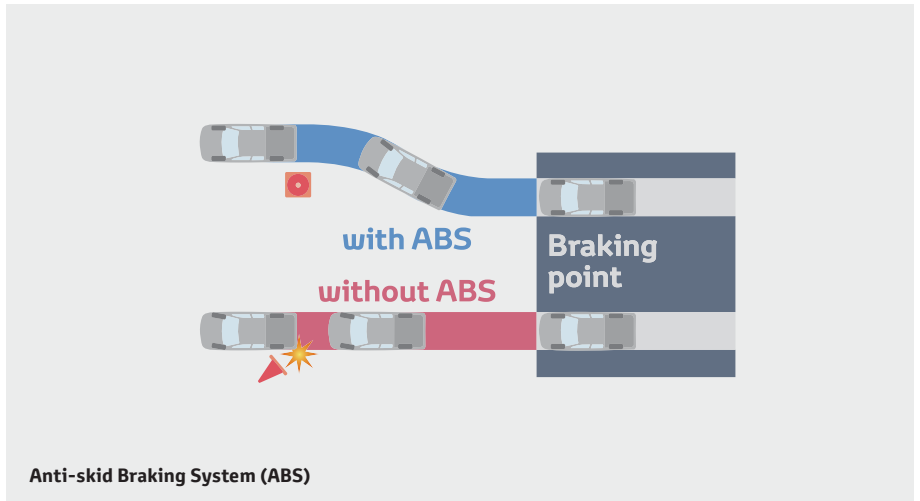

SR5 Double-Cab 4x4 models and SR Double-Cab Pick-up models with the VSC option also features EBD (Electric Brake-force Distribution) which optimises the distribution of braking force between the front and rear wheels and BA (Brake Assist) which interprets a quick hard push of the brake pedal as emergency braking and supplements the braking power so that the car slows more rapidly.

Should a collision occur, pretensioned seatbelts hold you in place, and twin SRS airbags help cushion the impact. And in the 4x4 SR and SR5 models, front, side and full length curtain SRS airbags provide even greater protection. WorkMate and SR Pick-ups also include a rear deck guard

across the cabin's rear-window to help protect passengers from any shifts in the load under heavy braking or impact.

All this attention to detail and clever technology is designed with one thing in mind – to help keep the people you care about safe. So whether it's looking out for number one on the work run, or keeping the kids safe and sound on the school run, HiLux has been designed to make the safety of you and your passengers top priority.

# Take on the rough with the smooth.

*Work can take you anywhere. And so can HiLux.  
Designed with flexibility in mind, the HiLux is available as a 4x2 or 4x4 – so you can enjoy as much control off-road as you do on. And with suspension designed to help give you a smooth, stable ride, whatever the load, whatever the conditions – you can tackle the toughest of terrain, without feeling every bump.*

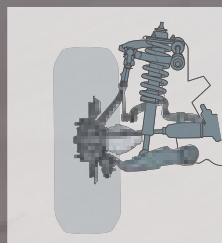

Front suspension

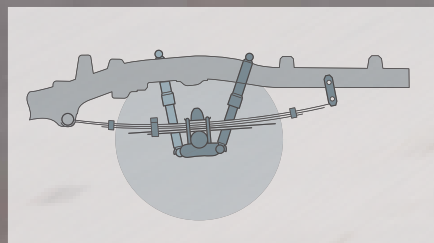

Rear suspension

Cornering performance is enhanced by the double wishbone coil-spring front suspension with a ball-joint mounted stabiliser bar and special valve structure on the shock absorber that responds to the surface of the road – or whatever surface you’re taking on.

Rear suspension is designed to create excellent steering stability and comfort, with a combination of leaf spring and twin-tube shock absorbers, helping minimise the effects

of a heavy load on performance. 4WD handling is further improved by double-row, roller-type axle bearings ensuring stability and high reliability and with a turning circle of just 12.4m, you’re never caught in a tight spot.

The overall experience? It’s about feeling at home, on even the most foreign of soil. From hard work to serious play – the HiLux is built tough enough to take you wherever your sense of adventure takes you.







**TOYOTA**

BBP-17Y

4x4 SR Double-Cab Pick-up V6 with option pack in Sterling Silver.



SR5 interior 4x4 Turbo-diesel model shown



Climate control - SR5 model shown



SR5 4x4 Petrol Double-Cab model shown



SR Single-Cab 4x2 model shown



Automatic transmission and shift lever - SR5 4x4 model shown



Rear seat storage space - SR5 Double-Cab model shown



## Tough love.

*HiLux may be tough-as-nails on the outside, but step inside and you'll find a welcoming, comfortable, well-thought-out space.*

With clever management of NVH (Noise Vibration and Harshness) you're shielded from whatever chaos is going on around you – unless of course you take the kids out with you.

The interior has a modern appeal with tone-on-tone trim as standard. The instrument meter is seamlessly integrated into the dash, creating a single, smooth unit that's not just easy to see, but stylish.

Storage isn't a problem, with large moulded door pockets on all models creating more space to stash your stuff, while Extra-Cab and Double-Cab models have hidden storage compartments under the rear seats.

When you're clocking up the hours behind the wheel comfort and a quality entertainment system can make all the difference to your day. The front seats have a slim profile, maximising leg-room and comfort, with a cushioned panel to support your hips which helps reduce fatigue on those longer drives.

For maximum music on the move all models come with an AM/FM MP3 compatible audio system with CD player. There's also USB input to plug in compatible iPods<sup>1</sup> and MP3 players<sup>2</sup> while inbuilt Bluetooth<sup>3</sup> allows you to safely and conveniently keep in touch while on the go. The SR5 steps up to a six speaker system, including two front tweeters for an all-round sonic experience. On SR5, Satellite Navigation<sup>4</sup> comes as standard and a multi-information display featuring vehicle performance keeps you up to speed on your journey.

<sup>1</sup> iPod® is a trademark of Apple, Inc.

<sup>2</sup> Not all devices will be compatible and functionality will vary depending on the device.

<sup>3</sup> The Bluetooth™ word mark is owned by the Bluetooth SIG, Inc. Not all devices will be compatible and functionality will vary depending on the device.

<sup>4</sup> Current navigation mapping database encompasses major capital and primary national road networks, as well as offering some coverage of regional areas.

**Looks as tough  
as it talks.**

*Despite a reputation for being unbreakable,  
HiLux never compromises on style, with  
a bold, brash exterior that's every bit as  
appealing as what's on the inside.*





Up-front the aggressive full grille shows the beast has bite, while the streamlined clear-lens headlights will cut through even the darkest of nights.

The striking balance of workhorse toughness and contemporary styling mean HiLux looks just as at home downtown as it does outback. Letting you live whatever life you want to lead.

Heading up the range, the SR5 4x4, with its over-fender flares, sports bars and privacy glass, is a dynamic trailblazer, while its power-adjustable chrome mirrors and tough

side-steps help showcase what an advanced, yet stylish, workhorse it is.

To top it off, all SR5 variants also come with distinctive alloy wheels as standard<sup>1</sup>. The result of all this attention to detail is an exterior that combines toughness with style.

Whichever way you look at it, HiLux is an uncompromising vehicle that's always up for a challenge.

<sup>1</sup> Spare wheel available in steel.



Above images: SR5 models shown

4x4 SR5 Double-Cab Pick-up Turbo-diesel with optional Towbar, Towball and Trailer Harness accessory in Metal Storm (Sold separately).

# What's your HiLux of choice?

## 4x2 Range



Single-Cab Cab-Chassis 2.7L Petrol in Ink  
shown accessorised with after-sale dealer fitted steel tray

### WorkMate

An uncompromising workhorse for everyday adventures, the WorkMate is available as a Single-Cab Cab-Chassis or Double-Cab Pick-up – and power to get the job done everytime. With a choice of a 2.7 litre 4-cylinder petrol engine, or a 3.0 litre turbo-diesel, it's got power to burn, and the ultra-tough chassis means you can carry up to 1.3 tonnes<sup>1</sup> (4x2 2.7L Single-Cab Cab-Chassis M/T) – wherever you want to go.



Extra-Cab Pick-up Turbo-diesel in Glacier White

### SR

With all the features of the WorkMate – along with some additional kick and a range of great extras, the SR is a versatile beast. Choose from a Single, Extra or Double-Cab and from a Cab-Chassis or Pick-up. Engine-wise, it's your call whether you go for the 4.0 litre V6 petrol or 3.0 litre turbo-diesel with a powerful 343Nm of torque.



Double-Cab Pick-up V6 in Tidal Blue

### SR5

The ultimate in the 4x2 class is the SR5, a triumph of style and substance. With Satellite Navigation<sup>2</sup> as standard and plenty of room inside. Available in a 4.0 litre V6 petrol either in Extra-Cab or Double-Cab, the interior boasts a host of extras like a premium multi-function steering wheel, a 6.1" LCD touch-screen, six speaker audio system with Bluetooth™ compatibility<sup>3</sup> – for a little extra luxury among the tough stuff. Complete the look, with sports bars, alloy wheels and privacy glass on the rear windows.

# 4x4 Range



Double-Cab Pick-up Turbo-diesel in Sterling Silver

## WorkMate

The 4x4 HiLux WorkMate delivers great performance on and off-road, offering outstanding value for money. With 16" steel wheels and the ability to handle a wide range of challenging terrains, it makes light work of the most adventurous play.



Single-Cab Cab-Chassis Turbo-diesel in Charcoal Grey shown accessorised with after-sale dealer fitted steel tray

## SR

A step-up from the WorkMate, the 4x4 gives you tough steel side-steps for an even tougher look, and easier access. You can also choose to make the tough going even safer with the Double-Cab Pick-up option pack, featuring driver assist technologies including 17" steel wheels, VSC, TRC, EBD and BA to help keep you and your passengers safe as houses.



Extra-Cab Pick-up Turbo-diesel in Velocity Red

## SR5

The ultimate HiLux, available in Extra-Cab or Double-Cab variants and packed full of style and special features. 15" alloy wheels come standard on Extra-Cab models while 17" alloys are standard on the Double-Cab models. The Double-Cab also comes with VSC, TRC, EBD and BA safety features as standard, along with all the intelligent technologies and luxuries in the SR5 4x2. The SR5 look is perfected with sports bars, alloy wheels and privacy glass on the rear windows.

1 Kerb, tare and payload weights are nominal and will vary depending on options and accessories and tray/body type.  
2 Current navigation mapping database encompasses major capital and primary national road networks, as well as offering some coverage of regional areas.  
3 The Bluetooth™ word mark is owned by the Bluetooth SIG, Inc. Not all devices will be compatible and functionality will vary depending on the device.

# Have it your way.



4x4 SR Double-Cab Pick-up V6 with option pack in Sterling Silver accessorised with Weathershields, Roof Racks, Kayak Carrier, Steel Bull Bar, Superwinch, Driving Lights, 17" Alloy Wheels with BF Goodrich Tyres, and Ute/Tailgate Liner. All Accessories sold separately.



**Alloy Bull Bar**



**Steel Bull Bar, Driving Lights and Superwinch**  
(Sold separately)



**Deluxe Nudge Bar**



**Tray Body Range**  
(Heavy Duty Alloy Tray pictured)



**Ute/Tailgate Liner**



**Sports Bar**  
(Sports bar pictured applicable to Double-Cab WorkMate and Double-Cab SR model)



**Reversing Camera (Tray Body)<sup>1,4</sup>**



**Bonnet Protector & Headlamp Covers**  
(Sold separately)



**Weathershields**  
(Sold separately)



**Roof Racks**



**Towbar with Rear Step<sup>2</sup>**  
(Towball and trailer wiring harness sold separately)



**Towbar, Towball and Trailer Wiring Harness<sup>2</sup>**  
(Sold separately)

Everyone's different. That's why HiLux offers stacks of Dealer Fit Genuine Accessories that will help you whip yours into shape. So check out some of the ways you can customise the set-up to make your HiLux your everyday hero.



4x2 WorkMate Single-Cab Cab-Chassis Turbo-diesel accessorised with Heavy Duty Steel Tray, Stainless Steel Nudge Bar, Driving Lights and Bonnet Protector. All Accessories sold separately.



**Smooth Canopy with Roof Racks**  
(Roof Racks available October 2011. Sold separately)



**Tray Soft Tonneau Cover**



**Hard Sports Tonneau Cover**



**Reversing Parking Sensors (Tray Body)<sup>1</sup>**

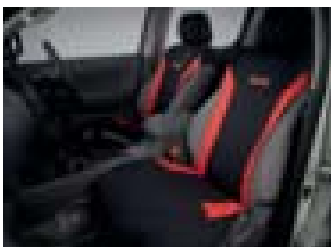

**Sports Vest Seat Covers**



**Canvas Style Seat Covers**



**Alloy Wheels 17"**  
(BF Goodrich tyres sold separately at participating Dealers)



**Audio Visual Unit with Satellite Navigation<sup>3</sup>**

**TOYOTA GENUINE ACCESSORIES ARE COVERED BY OUR TOYOTA WARRANTY\***

Some Toyota Genuine Accessories are not applicable to all models. See your Toyota dealer for advice regarding Toyota Genuine Accessories. Pictured Accessories are all sold separately. For a comprehensive guide on the entire range of Toyota Genuine Accessories, visit our website at [accessories.toyota.com.au](http://accessories.toyota.com.au).

\* All Toyota Genuine Accessories purchased and fitted to a Toyota are warranted for the remainder of the New Vehicle Warranty or 12 months, whichever is greater. Toyota Genuine Accessories purchased from an authorised Toyota Dealer over the counter are warranted from the date of purchase for one year. Conditions apply. The Toyota Genuine Accessories Warranty does not limit and may not necessarily exceed your rights under the *Competition and Consumer Act 2010*.

- 1 Reversing Camera/Park Assist is designed as a driver assist device only and should not be used as a substitute for skilled driving and safe parking practices. The area into which the vehicle is to be reversed must be visually monitored by the driver while parking.
- 2 Towing capacity subject to regulatory requirements, towbar design, vehicle design and towing equipment limitations. Ask your Dealer for details of Toyota Genuine Towbar capacity and availability.
- 3 Current navigation mapping database encompasses major capital and primary national road networks, as well as offering some coverage of regional areas.
- 4 Requires AVN or Display Audio Unit.

# A HiLux 4x4 to suit every need.

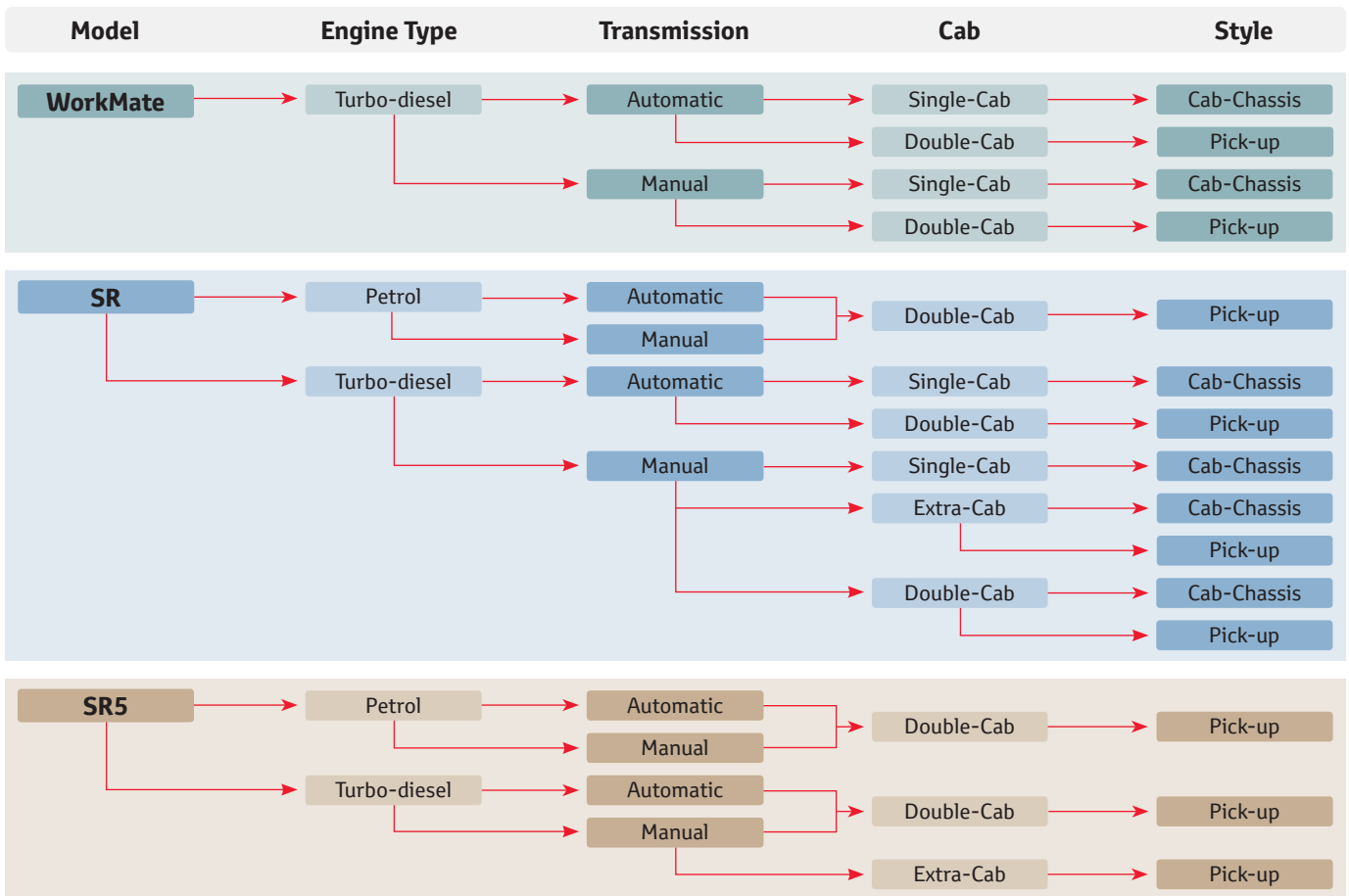

# A HiLux 4x2 to suit every need.

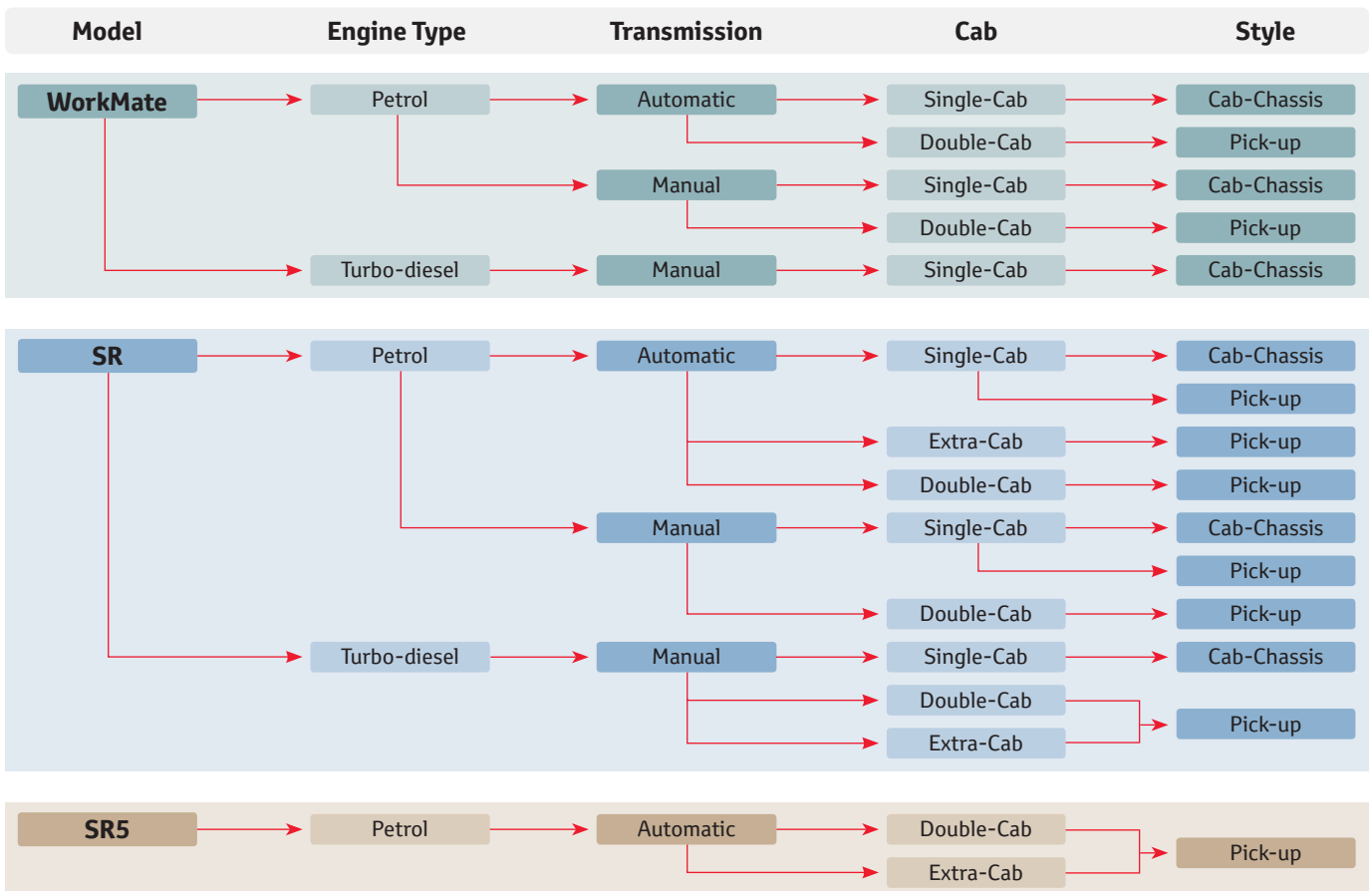

# The Toyota Advantage



## Pay no more from one logbook service to the next with Toyota Service Advantage.

New Toyotas come with Toyota Service Advantage. That means you'll pay the same low capped-price from one logbook service to the next for the first three years or 60,000km, whichever comes first<sup>1</sup>. So you'll enjoy the peace of mind of knowing in advance what your servicing costs will be. Better still, your Toyota will be serviced by Toyota-trained Technicians who know your vehicle inside out and only ever use Toyota Genuine Parts. For the full benefits of Toyota Service Advantage consult a Toyota Dealer or visit [advantage.toyota.com.au](http://advantage.toyota.com.au)

## TOYOTA WARRANTY

### The Toyota Guarantee.

We are confident that all of our vehicles will be as reliable and dependable as you need them to be. We understand that a new car purchase can often be a big decision. You need to feel confident that not only are you making the right decision now, but you are making a decision that won't end up costing you dearly in the future. That is why every new Toyota is proudly backed by a 3 year/100,000km warranty<sup>2</sup> (whichever occurs first), which provides you with peace of mind and carefree motoring.

## TOYOTA EXTRA CARE

### Extend your peace of mind.

The Toyota Extra Care Extended Factory Warranty allows you to extend your original factory warranty for up to 3 years and is available on most new and used Toyota vehicles, providing you with protection from unexpected repair bills and more importantly a little extra peace of mind<sup>3</sup>. Should you break down we also offer Roadside Assist, a reliable breakdown service with round the clock reassurance and assistance. Toyota Extra Care is that extra helping hand when you need it most. For more details visit [toyotaextracare.com.au](http://toyotaextracare.com.au)

## TOYOTA INSURANCE

### All the insurance coverage you could need.

Could you afford costly repairs or having to replace your vehicle altogether? At Toyota Insurance<sup>4</sup> we understand that your vehicle is a critical part of your life and can offer you a motor insurance solution designed specifically for Toyota vehicles. Our Comprehensive Motor Vehicle Insurance benefits include<sup>4</sup>:

- Replacement of your Toyota vehicle with a new Toyota following a total loss if your vehicle is less than 3 years old and has travelled less than 100,000km
- Genuine new Toyota parts replacement promise for Toyota vehicles less than 5 years old
- Genuine Toyota Quality Repair Guarantee on authorised repairs for the duration of your vehicle ownership

Toyota Insurance also offers optional Finance Gap Insurance, Payment Protection and Extended Warranty Insurance<sup>4</sup>. Visit [toyotainsurance.com.au](http://toyotainsurance.com.au) for more details about the coverage we offer.



### Finance to get you in the driver's seat.

Toyota Financial Services<sup>5</sup> can offer you a range of easy vehicle finance options available for you to organise conveniently at your preferred Toyota dealership. Whether you require a simple personal vehicle loan, a novated lease for you or your employees, or serviced leasing on your small-business tool of trade vehicles, we can help. Toyota Financial Services is the best way to finance your Toyota, visit [toyotafinance.com.au](http://toyotafinance.com.au) to find out why.

1 Standard scheduled servicing (normal operating conditions) up to the first 6 services. Excludes Government and Rental vehicles. Contact your Toyota Dealer or go to [advantage.toyota.com.au](http://advantage.toyota.com.au) for other exclusions and eligibility.

2 New Vehicle Warranty expires 3 years from date of first delivery or 100,000 kms, whichever occurs first. Refer to the warranty conditions. The New Vehicle Warranty does not limit and may not necessarily exceed your rights under the *Competition and Consumer Act 2010*.

3 The Toyota Extra Care Extended Factory Warranty Agreement is between Toyota Motor Corporation Australia Limited ABN 009 686 097 (TMCA) and the purchaser of the motor vehicle and is administered by Toyota Financial Services (TFS) a division of Toyota Finance Australia Limited ABN 48 002 435 181 on behalf of TMCA. Terms and conditions apply. Available on most new and used Toyota vehicles up to 8 years old that have travelled less than 120,000 kms. For more information visit [toyotaextracare.com.au](http://toyotaextracare.com.au)

4 Terms and conditions apply. Before making a decision about any of the insurance products, please refer to the current Product Disclosure Statement (PDS) for the relevant product available from participating dealers, via the Toyota Insurance website at [toyotainsurance.com.au](http://toyotainsurance.com.au) or by calling 137 200. Toyota Insurance is a division of Aioi Nissay Dowa Insurance Co., Ltd. ABN 39 096 302 466 AFSL Number 254489 (Andia). Nothing within the Toyota Insurance Extended Warranty products affects any statutory rights you may have under the *Competition and Consumer Act 2010*.

5 Toyota Financial Services is a division of Toyota Finance Australia Limited ABN 48 002 435 181, Australian Credit Licence No 392536.

IMPORTANT NOTICE PLEASE READ: Toyota Australia uses its best endeavours to ensure this material is correct when published. You must check with your authorised Toyota dealer when ordering to ensure the vehicle with your chosen specifications, equipment and colour is available and that the vehicle can be delivered within the timeframe suitable to you. When ordering accessories, you must check with your authorised Toyota dealer to ensure the accessory's design, features and colours are available and will fit your vehicle. Colours displayed here are a guide only and may vary from actual colours due to printing/display processes. Certain accessories when fitted will require the removal of standard equipment. Standard equipment may be retained by Toyota Australia. Toyota Australia reserves the right to change, without notice, at any time prices, colours, materials, equipment, specifications and discontinue colours/models. To the extent permitted by law, Toyota Australia will not be liable for any damage, loss or expense incurred as a result of reliance on this material in any way. Distributed nationally (other than in Western Australia) by Toyota Motor Corporation Australia Limited ABN 64 009 686 097, 155 Bertie St, Port Melbourne 3207. Material distributed in Western Australia by or on behalf of Prestige Motors Pty Ltd (for vehicles) and by Eastpoint Pty Ltd (for parts/accessories). Toyota Australia makes no warranties regarding (and will not be liable for) the accuracy of materials distributed in Western Australia. PART NUMBER: HILUX0911. VALID: X2069. PRINTED: SEPTEMBER 2011. GTO1411.

“We are a group of passionate perfectionists who can’t let well enough alone...That’s Toyota. That’s the spirit. And that’s our contribution to the world.”

— Eiji Toyoda



Yaris



Corolla



Rukus



Prius



Camry



Hybrid Camry



Aurion



Tarago



RAV4



Kluger



FJ Cruiser



Prado



LandCruiser 200 Series



LandCruiser 70 Series



HiLux

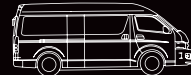

HiAce Commuter Bus



HiAce Van



Coaster