

This Brochure is prepared by Daimler AG and it predominantly reflects the capabilities and performance of vehicles sold in Europe. Some characteristics, capabilities, performance features and optional extras (e.g. towing systems) may not be available or may not apply in Australia or under Australian conditions. The information in this Brochure is therefore indicative, illustrative and provided only for guidance and should not be relied on. To obtain current and accurate information on a vehicle and any options applicable to Australia, contact your local authorised Mercedes-Benz dealer.



Mercedes-Benz

The C-Class

Coupé



Mercedes-Benz

ral star, the strong shoulders, short overhangs and a powerfully thrusting tail end. Even
systems are a sign of the times. That's why the C-Class Coupé features optimised engine
ial comes courtesy of the standard-fit ECO start/stop function and the optionally avail
little bit further ahead than you think. Thanks to numerous safety systems which take
s the ADAPTIVE BRAKE control system, which has the ability to apply the brakes in an
s reassuring for all concerned, not just your heart rate. In this cockpit you will experie
sports suspension and the more direct steering ensure tangibly greater lateral dynam
you sharpen the sports mode – S-Mode for short. The drive system then reacts tangib
e S-Mode can be switched off at all. The answer is: so that you can switch it back on ag
o be sooner. The AMG sports seats upholstered with ARTICO man-made leather/DINAM
h red seat belts. **More style per hour.** Further interior highlights include the silver-col
als in brushed stainless steel. A dab of the foot is all it takes to get the blood really p



The C-Class Coupé embodies the tension between style and urgency. Externally, it is a compellingly attractive, dynamic coupé which expresses a strong sense of forward motion. Inside, it is a place to sit back and relish every corner and twist in the road in an ambience of sportiness and functional perfection. The result is sheer driving enjoyment.

Support is provided by engines equipped with the ECO start/stop function as standard, the sporty set-up of the AGILITY CONTROL suspension with selective damping system and features which set the standard for safety.

At a glance | from page 4 Insight | from page 22

Featured models:
C 350 BlueEFFICIENCY palladium silver metallic cover and from page 2 AMG 7-spoke light-alloy wheels, flamenco red leather, dark longitudinal-grain aluminium trim, AMG sports package
C 250 CDI BlueEFFICIENCY diamond white metallic BRIGHT from page 12 5-spoke light-alloy wheels in “sterling silver”, black ARTICO man-made leather, Style package
C 250 Sport designo magno platinum from page 16 7-twin-spoke light-alloy wheels in high-gloss black, high-sheen, ARTICO man-made leather / DINAMICA microfibre in black

The illustrations may show accessories and optional extras which are not part of standard specification

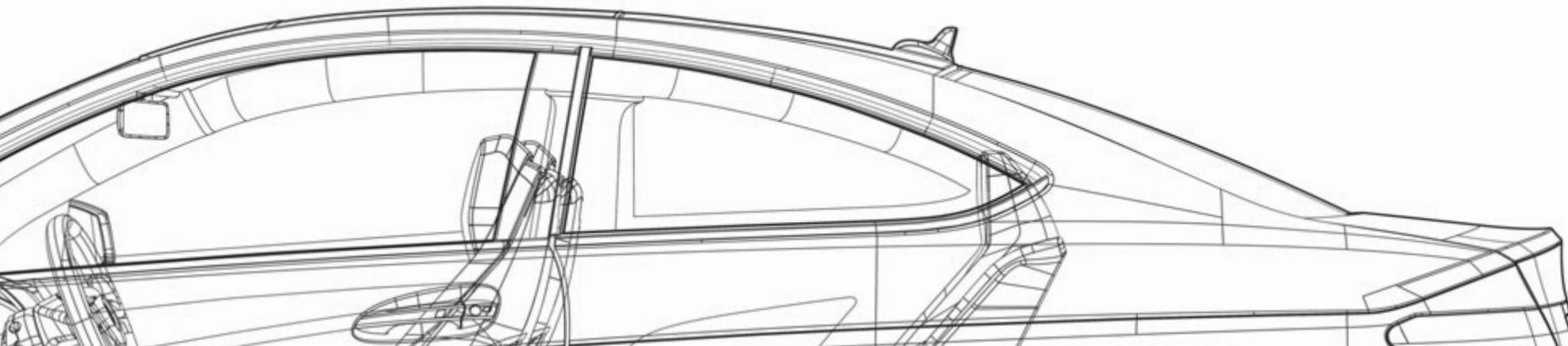

Stylish agility: BlueEFFICIENCY, diesel and petrol engines, transmissions and chassis

Drive system & chassis | from page 28

Reassuringly safe: technologies in the integral safety concept for the “Safe driving”, “In the event of danger”, “In an accident” and “After an accident” phases

Safety | from page 36

Entertaining relaxation: multimedia and assistance systems, interior appointments

Comfort | from page 40

Impressively laterally dynamic: the C-Class Coupé Sport with superbly sporty cornering characteristics

Model variant | from page 46

Outstandingly driven: the flagship C 63 AMG Coupé with a 6.3-litre V8 engine

AMG | from page 48

Desirable versatility: standard equipment and optional extras, packages, light-alloy wheels and accessories

Equipment and appointments | from page 54

Exciting professionalism: everything about MercedesCard, Mercedes-Benz Financial Services, Mercedes-Benz mobility, Mercedes-Benz Museum, test drive, Interactive Owner’s Manual and Mercedes-Benz Guides, mobile internet, service contracts and accident repairs

Services | from page 72

Detailed listings: technical data, dimensions and paintwork

Facts & colours | from page 74



Two doors, no compromises. As coupé as it gets!

The low silhouette with a long, arrow-shaped bonnet. The upright, louvred radiator grille with a central star, the strong shoulders, short overhangs and a powerfully thrusting tail end. Every inch underlines the character of this coupé: built for people who don't like to stand still.



Brief care instructions:
needs tarmac beneath its tyres every day







Are you concerned about the environment? We're right there with you

Intelligent drive systems are a sign of the times. That's why the C-Class Coupé features optimised engine technology – with a choice of four efficient petrol variants and two diesel variants. Additional fuel-saving potential comes courtesy of the standard-fit ECO start/stop function and the optionally available 7G-TRONIC PLUS automatic transmission. Good news for CO₂ emissions. → Page 30–34



Welcome to the coupé lounge







Maybe your first Mercedes.
Almost certainly not your last





A silver Mercedes-Benz C-Class Coupé is parked on an airfield. In the background, a private jet is visible on the tarmac. The scene is set during the day with a clear sky and some distant hills. The car is positioned in the lower-left foreground, angled towards the right. The jet is in the middle ground, and the airfield extends to the horizon.

Just what you need: a seventh sense

The C-Class Coupé is always a bit further ahead than you think, thanks to numerous safety systems which take account of virtually every eventuality and help defuse hazardous situations. Take the ADAPTIVE BRAKE control system, which can apply the brakes in anticipation of danger. So if the worst comes to the worst, the car can be brought to a stop even more quickly. It's good for all concerned, not just your heart rate.

Lateral dynamite

In this cockpit you will experience what cornering really means: the C-Class Coupé Sport – engineered by AMG. The specially tuned AMG sports suspension and the more direct steering ensure tangibly greater lateral dynamics. The shortest route between two points now feels like a bend.







A silver car is shown from a rear three-quarter view, driving on a dark track at night. The track has a yellow line on the edge. In the background, there is an airport terminal with several airplanes parked at gates, illuminated by bright lights. The sky is dark with some clouds.

S-plosion at the push of a button

Sport says it all: with the touch of a button you sharpen the sports mode – S-Mode for short. The drive system then reacts tangibly more directly. The shift points change. The driving experience is intensified. You will ask yourself why the S-Mode can be switched off at all. The answer is: so that you can switch it back on again.

→ Page 46



The sharpest centrifuge of all time

Every road turns into a bend sooner or later. If you're driving the C-Class Coupé, you'll probably prefer it to be sooner. The AMG sports seats upholstered with ARTICO man-made leather/DINAMICA microfibre in black with contrasting red topstitching provide exceptional support and are equipped with red seat belts. Further interior highlights include the silver-coloured steering-wheel gearshift paddles, the brushed-aluminium trim with a dark longitudinal grain and the sports pedals in brushed stainless steel. A dab of the foot is all it takes to get the blood really pumping.





Best-time machine

The DTM AMG Mercedes C-Coupé has been built according to a meticulously designed safety concept with an innovative safety cell at its heart. This comprises a carbon-fibre monocoque plus a safety cage made out of high-strength steel.

The C-Class family can already look back at an exemplarily successful history. Even in its first season, 1988, Mercedes-Benz became the world championship runner-up in partnership with the AMG motorsport experts. The vehicle in question was the 190 E 2.5-16 EVO, the racing version of the famous C-Class predecessor. And Mercedes-Benz enjoyed success in the fight for the top positions in the years that followed, too: it was the runner-up in the world championships of 1991 and 1993, took its first DTM championship title in 1992 – and again in 1994, 1995, 2005, 2006 and 2010. The C-Class is the most successful vehicle in the history of the DTM.

But the C-Class has by no means seen its best time yet. For the goal is to achieve the best time in every race with the DTM AMG Mercedes C-Coupé, too.

upholstery and trim. In the event of an accident. Metallic paints. Sound system. Petrol engine & suspension. Optional extras. Fuel consumption. Interior. In the event of danger. LED lights. ESP[®]. Dimensions. Standard equipment. Light. Multimedia systems. Drive system. Memory package. Transmissions. Surround sound system. Wheels. Interior. Safe driving. CO₂ emissions. Trim. Assistance systems. BlueEFFICIENCY. In an accident. Metallic paints. Petrol engine. Top speed. Chassis & suspension. Optional extras. Fuel consumption. Interior. Airbags. In the event of danger. Colours. Climate control. Seats. ESP[®]. Dimensions. Standard equipment. Light. Multimedia systems. Memory package. Transmissions. Surround sound system. Wheels. Interior. Acceleration. Interior. Services. Safety. Assistance systems. Upholstery and trim. In an accident. Metallic paints. Alloy wheels. Top speed. Optional extras. Chassis & suspension. Fuel consumption. Paintwork. Performance data. Airbags. **The facts.** Paintwork. Total displacement. Climate control. Seats. Dimensions. Services and appointments. Light-alloy wheels. Memory package. Transmissions. Cylinders. Sa

28 BlueEFFICIENCY**29 C-Class Coupé BlueEFFICIENCY****30 Diesel engines**

4-cylinder

32 Petrol engines

4-cylinder

6-cylinder

34 Transmissions

6-speed manual transmission

7G-TRONIC PLUS

35 Chassis & suspension

AGILITY CONTROL suspension

Dynamic Handling package with sports driving mode

36 Integral safety concept

ATTENTION ASSIST

Intelligent Light System

Lane Tracking package

Driving Assistance package Plus

PRE-SAFE® Brake and BAS PLUS

PRE-SAFE® system

NECK-PRO head restraints

Restraint systems

Active bonnet

Mercedes-Benz emergency call system

Measures after an accident

40 Multimedia systems

COMAND Online

Harman Kardon® Logic 7® surround sound system

Audio 20

Becker® MAP PILOT

42 Assistance systems

Speed Limit Assist

Reversing camera

PARKTRONIC, incl. Parking Guidance

44 Seats

Coupé seats

Individual rear seats

Memory package

46 C-Class Coupé Sport

48 **C 63 AMG Coupé**50 **C 63 AMG technology**

AMG 6.3-litre V8 engine

AMG sports suspension

AMG SPEEDSHIFT MCT 7-speed

sports transmission

52 **AMG Performance Studio**54 **Standard equipment**55 **Optional extras**56 **Equipment packages**

AMG Sports package

AMG Plus Sports package

designo

Style package

62 **Upholstery and trim**68 **Wheels**

Standard wheels

Optional wheels

AMG wheels

70 **Genuine accessories**72 **Services**

MercedesCard

Mercedes-Benz Financial Services

Mercedes-Benz mobility

Mercedes-Benz Museum

Test drive

Interactive Owner's Manual and

Mercedes-Benz Guides

Mobile internet

Service contracts

Accident repairs

74 **Dimensions**74|77 **Paintwork**75 **Technical data**

BlueEFFICIENCY – fast forward to tomorrow

Mercedes-Benz is quicker at getting future technologies to where they matter most: on the road. With the exception of the G-Class and R-Class, all of our 4, 6 and 8-cylinder models now include BlueEFFICIENCY measures that help to reduce your impact on the environment significantly. Our BlueEFFICIENCY concept comprises innovations for efficient mobility as well as optimised processes all the way along the value chain.

The BlueEFFICIENCY measures – the Mercedes-Benz efficiency package. A comprehensive set of vehicle enhancements saves fuel and eases the burden on the environment. Each model combines the most efficient engine with the very latest aerodynamic and energy-management measures, including the ECO start/stop function available for most models. The BlueDIRECT V6 and V8 petrol engines featured in many model series deliver more power while reducing consumption by up to 25%. The new BlueEFFICIENCY Edition badge is reserved for the most economical models in selected ranges. These vehicles employ special measures to save weight, reduce air resistance or optimise the drivetrain and thereby achieve even lower fuel consumption and CO₂ figures.

BlueTEC – the clean diesel. A modular emission-control system makes BlueTEC an exceptionally clean diesel technology, as it not only removes up to 95% of the particulate matter from the exhaust gases but also reduces nitrogen oxides by up to 90%. What remains is mainly water and nitrogen.

HYBRID – combustion engine and electric motor intelligently combined. A well-coordinated team can achieve more, as hybrid technology certainly proves. The electric motor supports the engine during the journey – e.g. with a boost effect for more powerful acceleration – or it acts as a generator, recuperating energy during braking in order to charge the battery (regenerative braking). The latest-generation hybrid drive system is capable of all-electric operation for up to one kilometre at a maximum speed of 35 km/h and also allows efficient, emission-free coasting at speeds below 160 km/h by shutting off the engine on the overrun and disengaging the drive system. And for the first time, these benefits are also available in a premium-class diesel model – without any loss of spaciousness. The E 300 BlueTEC HYBRID¹ is also the world's most economical luxury-segment model.

Innovative drive systems that break new ground.

In mid-2013, our electric drive technology will be moving into the fast lane with the arrival of the SLS AMG Coupé Electric Drive², which takes electric driving into a whole new dimension. This super sports car equipped with four synchronous electric motors is our second production-ready electric car and delivers superb performance figures: 551 kW and 1000 Nm make it the most powerful AMG high-performance model ever, yet it produces no local emissions. Another innovative alternative, the hydrogen drive, has also taken to the road at Mercedes-Benz with a small-scale series of B-Class models that use a fuel cell to generate power for the electric motor. Finally, the F 125! represents the future of zero-emission motoring in the luxury class.

But that's not all: under the banner "Design for Environment", we look at a vehicle's entire lifecycle and work hard to preserve the environment, all the way from the planning stage through to recycling. What's more, we are involved in the development of alternative fuels and carry out research in the field of bionics.

Further information about our comprehensive measures can be found at: www.mercedes-benz.com/blueefficiency

¹ E-Class E 300 BlueTEC HYBRID Saloon: the vehicle complies with the Euro 5 emissions standard. Fuel consumption – urban: 4.3–4.2 l/100 km, extra-urban: 4.3–4.2 l/100 km, combined: 4.3–4.2 l/100 km; CO₂ emissions combined: 112–109 g/km

² SLS AMG Coupé Electric Drive – CO₂ emissions combined in g/km: 0; electrical consumption combined in kWh/100 km: 26.8 The figures shown were obtained in accordance with the prescribed measuring process (Directive [EC] 715/2007 in the currently applicable version). The figures are not based on an individual model and do not constitute part of the product offer; they are provided solely for purposes of comparison between different vehicle models

C-Class Coupé BlueEFFICIENCY

At Mercedes-Benz, BlueEFFICIENCY stands for trend-setting efficiency technologies and innovative measures. The C-Class Coupé models work with BlueEFFICIENCY technologies



Thanks to BlueEFFICIENCY, the C-Class Coupé requires very little fuel. That's because the engine is stopped automatically – largely unnoticed by the driver – when the car is at or coming to a standstill. Intelligent energy management reduces the energy consumption of ancillary components. Tyres with optimised rolling resistance and the car's optimised aerodynamics further lower the amount of energy consumed.

- 1 Radiator shutter
- 2 Improved aerodynamics
- 3 Weight optimisation
- 4 Engine optimisation
- 5 Intelligent energy management
- 6 ECO start/stop function
- 7 Driver information for energy-saving driving
- 8 Tyres with optimised rolling resistance
- 9 Energy-saving control of ancillary components
(power steering pump, fuel pump in the case of diesel engines)
- 10 Refrigerant compressor only activated when actually needed

Diesel engines

The diesel engines for the C-Class Coupé make for efficient, refined and powerful progress. They have higher outputs yet can consume far less fuel than their conventional counterparts

4-cylinder engines. The diesel powerplants incorporate a wealth of efficient technology. As a result, their output is up to 20% higher than that of comparable older engines: the C 220 CDI BlueEFFICIENCY delivers 125 kW (170 hp), the C 250 CDI BlueEFFICIENCY 150 kW 204 (hp). At the same time, the torque of both engines has been increased

by up to 25%, while fuel consumption and CO₂ emissions are up to 23% lower. Both models meet the requirements of the Euro 5 emissions standard.

One of the reasons behind the impressive performance of the diesel engines is the maximum injection pressure of up to 2000 bar. What's more, the required fuel quantity is metered extremely precisely – a sound basis for efficient and on-demand use of energy.

The diesel engines' good consumption/output ratio is also down to their optimised combustion chamber design, which offers ideal conditions for maximising both clean combustion and energy efficiency. At the same time, the optimised alternator management contributes to lower consumption. A further technology which promotes responsible-minded driving pleasure is the efficiency-enhancing turbocharger. Plus there are two balancer shafts to ensure even smoother running.

Further efficiency measures. All models are equipped as standard with the ECO start/stop function which automatically turns off the engine when waiting at traffic lights or in a tailback. The ECO display available for many models provides feedback about the efficiency of the driving style which can then be adapted accordingly to reduce fuel consumption.

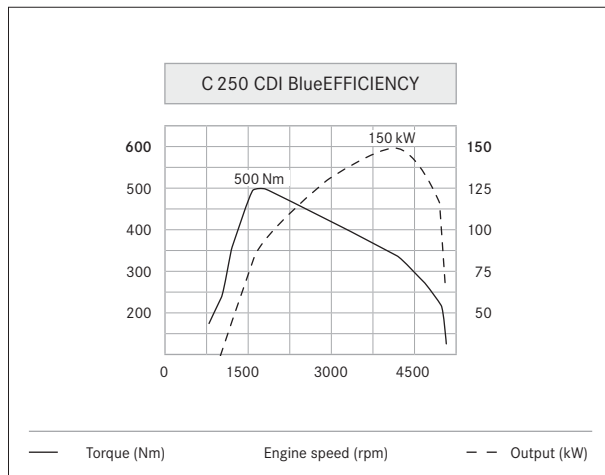

Impressive torque, even at low revs: ideal for spontaneous bursts of speed



The ECO display provides feedback about the efficiency of your driving style



The 4-cylinder diesel engine is available with a choice of two outputs (C 220 CDI BlueEFFICIENCY shown here)



The 6-cylinder engine for the C 350 BlueEFFICIENCY combines agility with responsible-minded energy consumption

Petrol engines

Agility and efficiency go hand in hand, as demonstrated by the petrol engines. Both the 4-cylinder models and the V6 powerplant combine a high level of refinement with low fuel consumption

4-cylinder engines. The current generation of 4-cylinder petrol engines pursues one major goal: more output and better acceleration figures in conjunction with lower fuel consumption. This is thanks to the direct injection system with an injection pressure of up to 200 bar, which ensures optimum preparation of the air/fuel mixture and therefore

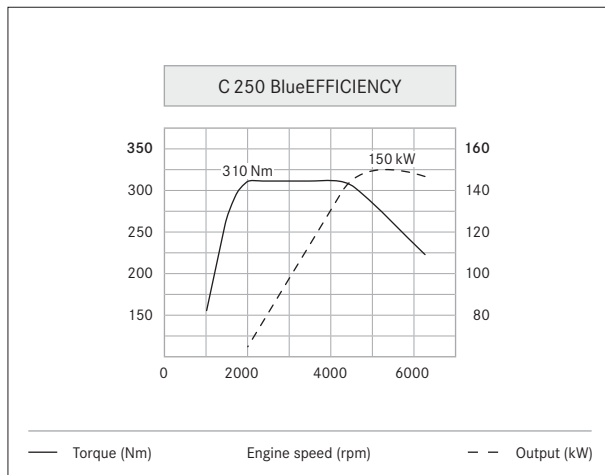

Not just remarkable in terms of performance data. The fuel-consumption figures are impressive, too

increases the effectiveness of the engine. The engine management also optimises the valve timing through continuously variable camshaft adjustment and piezo-controlled injectors with multi-hole valves. Savings have been achieved when it comes to the engine weight, in particular: the cylinder crankcase, for example, is made of aluminium and the crankcase was cast hollow. Further optimisations reduce consumption over and above this. They include ancillaries controlled according to requirements or, for example, the electromechanical steering system in the C 180 BlueEFFICIENCY. This only requires energy during the actual process of steering – without any compromises in terms of steering comfort.

Performance potential: the C 180 BlueEFFICIENCY accelerates from 0 to 100 km/h in just 8.5 seconds and goes on to reach a maximum speed of 225 km/h. The C 200 BlueEFFICIENCY has a top speed of 237 km/h and completes the sprint from 0 to 100 km/h in just 8.2 seconds. The C 250 BlueEFFICIENCY has a top speed of 240 km/h and completes the sprint from 0 to 100 km/h in 7.2 seconds.

6-cylinder engine. Economical, clean and high-torque: the C 350 BlueEFFICIENCY heralds the arrival of a new generation of technology – drive concepts that are sparing in their use of resources. With combined fuel consumption of 7.0–6.8 l/100 km, the engine has a peak output of 225 kW (306 hp) and can accelerate the C-Class Coupé from 0 to 100 km/h in a mere 6.0 seconds. The maximum torque of 370 Nm is on tap across a particularly wide engine speed range, so impressive power reserves are available for practically any driving situation.

Further efficiency measures. All models are equipped as standard with the ECO start/stop function which automatically turns off the engine when waiting at traffic lights or in a tailback. The ECO display available for many models provides feedback about the efficiency of the driving style which can then be adapted accordingly to reduce fuel consumption.

Transmissions

The two transmissions available for the C-Class Coupé deliver optimum pulling power in every driving situation

6-speed manual transmission. The 6-speed manual transmission combines sporty and economical driving. The ratio optimised in line with the engine output and the extremely precise, short shift travel make for exceptionally smooth gear changes. What's more, the integral gearshift-recommendation function, ECO start/stop function and current consumption indicator can help to optimise fuel consumption and reduce emissions. For instance, the ECO start/stop function stops the engine when the car is at or coming to a standstill – at traffic lights, for example – before restarting it when the clutch or accelerator pedal is pressed.

7G-TRONIC PLUS. The efficiency-optimised 7G-TRONIC PLUS automatic transmission is one of the major factors behind the exceptionally high level of driving enjoyment. The seven forward gears allow a constantly optimised rpm level, meaning that fuel consumption can be reduced. But the transmission technology also comes into play when the driver wants to accelerate powerfully or experience the full range of the C-Class Coupé's agility. For

example, individual gears can be skipped when overtaking or in situations requiring spontaneous acceleration. Furthermore, the transmission modes "E" (Economy) and "S" (Sport) can be selected at the touch of a button.

In conjunction with the optional AMG Sports package or AMG Plus Sports package and the optional Dynamic Handling package with sports driving mode there is an additional driving mode, "M", for manual shifting via the steering-wheel gearshift paddles. 7G-TRONIC PLUS is available as standard in the C 250 CDI Sport, in the C 250 BlueEFFICIENCY, in the C 250 Sport and in the C 350 BlueEFFICIENCY; for the other models this transmission is available as an option.

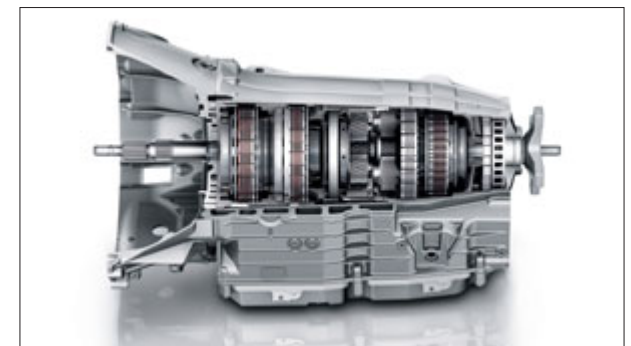

7G-TRONIC PLUS: one of over 18 million automatic transmissions produced in a period spanning more than 50 years

Chassis & suspension

The chassis technology for the C-Class Coupé allows comfort-oriented or sporty driving with supreme agility in almost any situation on the road

AGILITY CONTROL suspension (standard). The suspension with selective damping system can adjust automatically to the current road conditions and driving style. To do this, a valve automatically reduces the damping force at each wheel when the shocks caused by the road are weaker, thus lowering road roar and tyre vibration. If these shocks are stronger, the system's damping effect is enhanced and can improve the car's driving stability.

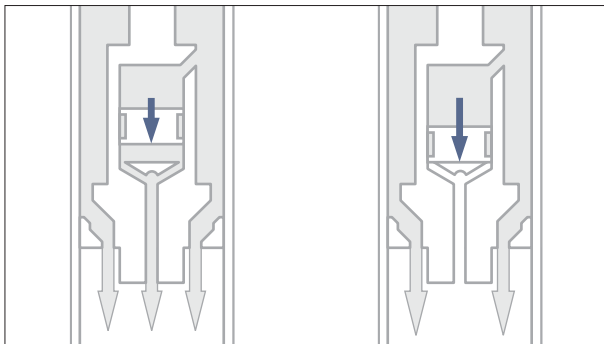

Outstanding agility and a high level of comfort: the AGILITY CONTROL suspension can adapt to any driving style

Dynamic Handling package with sports driving mode (option). The optionally available Dynamic Handling package with sports driving mode lends the C-Class Coupé even more dynamism and enhances the driving pleasure on every journey: in sports mode, the system not only adjusts the firmness of the damping, it also sharpens the accelerator response. Whatever the selected mode, the electronically controlled damping system constantly adjusts in line with the driving situation and the state of the road.



A suspension system lowered by 15 millimetres is one of the features which complements the Dynamic Handling package

Driving pleasure is further enhanced by the 3-spoke multifunction steering wheel in nappa leather with shift paddles (in conjunction with automatic transmission). What's more, the speed-sensitive sports steering has a modified steering response map and a direct ratio for an exceptionally sporty feel. Finally, the lower-slung chassis delivers extra dynamism when cornering at high speed.

Integral safety concept

The vision of accident-free driving impels us. With our integral safety concept we are coming closer to achieving this goal – this is a holistic approach which can increase safety in every situation

As the inventor of the car we feel that we have a special responsibility for road safety. This is why we are the first car manufacturer to have developed an integral safety concept which seamlessly blends measures to enhance active and passive safety. The holistic approach is subdivided into four phases and offers safety solutions for every situation. It includes systems for safe driving which help to avoid risks by warning you and coming to your aid in good time. Our unique PRE-SAFE® system kicks in in the event of danger and activates preventive measures for occupant protection. If a collision should still occur in spite of all the preventive measures, further technologies ensure protection as needed. We have also borne in mind the time immediately following an accident and developed solutions which can help prevent worse and facilitate rapid help.

A selection of these technologies for the “Safe driving”, “In the event of danger”, “In an accident” and “After an accident” phases is presented on the pages which follow.

Safe driving: ATTENTION ASSIST (included with the optional luxury multifunction steering wheel, standard for C 350 BlueEFFICIENCY). ATTENTION ASSIST can warn the driver and recommend taking a break as soon as it detects signs of driver drowsiness. To do this, it monitors the driver’s behaviour and, if this deviates from a previously determined profile, visual and acoustic warnings are emitted.



If ATTENTION ASSIST detects signs of drowsiness, the system recommends taking a break

Safe driving: Intelligent Light System (option). The system has six functions: country and motorway mode, enhanced fog lamps, cornering light function, active light function and Adaptive Highbeam Assist. The latter can adjust the low-beam headlamp range at any time to suit the prevailing traffic conditions. Main beam is activated if no road users are detected. The headlamps can be dimmed automatically as soon as an oncoming vehicle with its lights on is detected. The LED daytime running lamps enhance perceptual safety during the daytime.

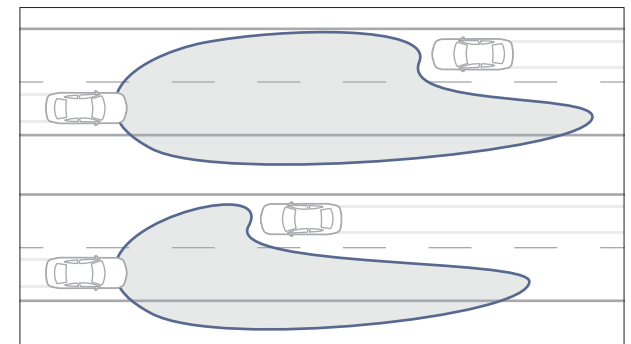

The Adaptive Highbeam Assist detects other road users with their lights on and ensures the greatest possible range of vision

Safe driving: Lane Tracking package (option). Lane Keeping Assist can detect a traffic lane based on the road markings and, if the car is about to leave its lane unintentionally, warn the driver by making the steering wheel vibrate gently. Blind Spot Assist, meanwhile, uses two radar sensors in the rear bumper to monitor the blind spot at speeds above 30 km/h and can warn the driver against dangerous lane changes. Lane Keeping Assist and Blind Spot Assist are also available separately as individual options.



Blind Spot Assist can warn of potential dangers acoustically and via a red warning triangle in the exterior mirror

Safe driving: Driving Assistance package Plus (option). At the touch of a button, the DISTRONIC PLUS proximity control can help the driver to maintain a set distance behind the vehicle ahead of it at speeds between 0 and 200 km/h and, if it detects the need, initiate braking. If necessary, the radar-based system can brake the car to a standstill. Active Blind Spot Assist helps the driver when turning or changing lanes. A warning triangle lights up in the appropriate exterior mirror if a vehicle is detected in the blind spot. If the driver fails to respond, the system can

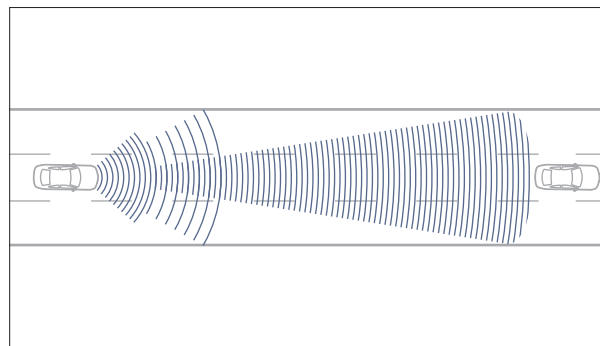

DISTRONIC PLUS can support drivers in automatically keeping their vehicle at a safe distance from the vehicle in front

prevent a possible accident by automatically braking individual wheels. If the vehicle unintentionally crosses the detected lane markings and risks leaving its lane, Active Lane Keeping Assist can warn the driver by gently vibrating the steering wheel. If there is still no response, individual wheels can be precisely braked to bring the vehicle back into lane. The system recognises contrasts on the road ahead and is therefore able to “read” lane markings. It also observes driving style and the line taken by the car, analysing these for movements typical of a vehicle leaving its lane unintentionally. In this way, the system is able to distinguish reliably between intentional and unintentional lane departures. The BAS PLUS braking assistance system and the PRE-SAFE® Brake – for a safe feeling on every journey.

In the event of danger: PRE-SAFE® Brake and BAS PLUS (components of the optional Driving Assistance package Plus). PRE-SAFE® Brake gives the driver a visual warning, then an acoustic alert, if a risk of collision is detected. During this phase, BAS PLUS calculates the brake pressure necessary to prevent a collision. If the braking force applied by the driver is not sufficient, the system automatically increases brake pressure in a way that ensures the remaining braking distance is used to the fullest advantage. This means that the driver of the vehicle behind also has a better chance of avoiding a rear-end collision.

If the driver fails to respond to the signals, PRE-SAFE® Brake intervenes with autonomous partial braking as a tangible warning. The system also triggers other measures in readiness for a possible collision. Autonomous emergency braking can be activated if there is still no reaction from the driver. The result is a clear reduction in impact speed and accident severity.

In the event of danger: PRE-SAFE® System (option). This anticipatory occupant protection system is able to detect certain critical driving situations in advance and activate preventive measures. If an imminent accident is detected, the system can close the side windows, move the front passenger seat equipped with the Memory package to a more favourable position and tension the front seat belts automatically. It can also close the sliding sun-roof where fitted.

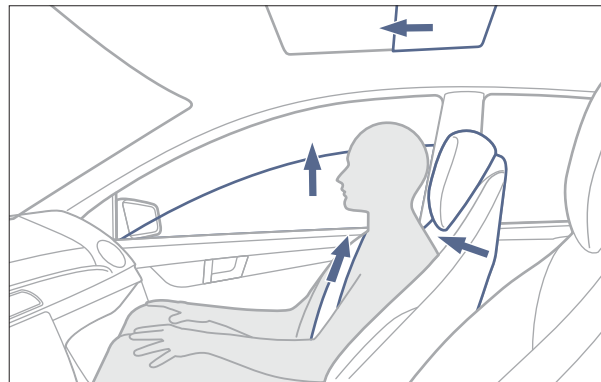

The PRE-SAFE® anticipatory occupant protection system can mitigate the consequences of accidents

In an accident: NECK-PRO head restraints (standard). In the event of a rear impact, the sensor-controlled NECK-PRO head restraints for the front occupants can be pushed forward and upward within a matter of milliseconds. They can thus reduce the gap between the head and the head restraint, thereby reducing the risk of injury.

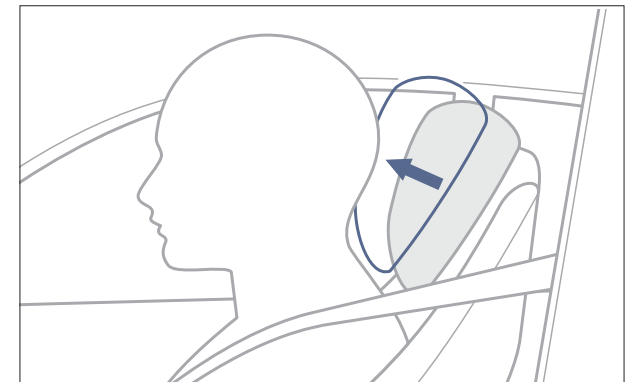

The NECK-PRO head restraints can help to reduce the risk of whiplash in an accident

In an accident: restraint systems (standard). 3-point seat belts, belt tensioners, belt force limiters and airbags are optimally coordinated with each other at Mercedes-Benz, so as to keep injuries to a minimum wherever possible. The C-Class Coupé has numerous airbags which can help prevent injuries to the driver and passengers in case of a collision: the driver's and front-passenger airbags, sidebags and pelvisbags at the front are standard, as is a kneebag for the driver plus windowbags. Sidebags for the rear are

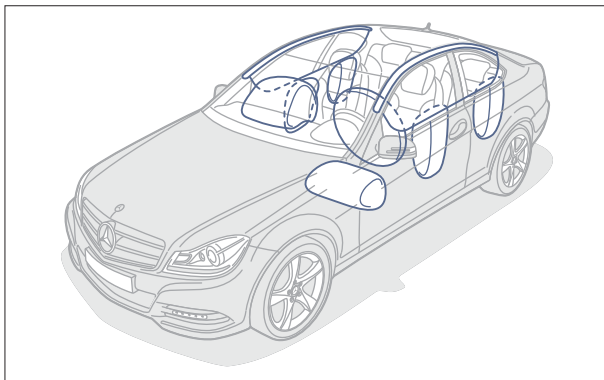

The robust passenger cell with defined crumple zones and the numerous airbags contribute to the exemplary occupant protection

also available as an option. If the crash sensors detect an accident the seat belts are automatically tightened at lightning speed in order to keep the occupants firmly in their seats. The belt force limiter, meanwhile, relaxes the belt during the accident in accordance with the particular situation in question, so as not to place too much of a strain on the occupants' chest.

In an accident: active bonnet (standard). The active bonnet can reduce the risk of injury to pedestrians and cyclists. In the event of an impact, its rear section is raised around five centimetres by means of spring force, thus creating additional deformation space to soften the blow for a pedestrian or cyclist.

After an accident: Mercedes-Benz emergency call system (component of COMAND Online). This system can make an emergency call automatically using a mobile phone which is on standby and connected to the vehicle as soon as the restraint system detects an accident.

At the same time, the GPS position data and other data about the vehicle are transmitted to the Mercedes-Benz emergency call centre, after which a voice connection is established. The emergency control system can also be triggered manually.

Measures after an accident. In order to reduce consequential damage and, if necessary, to support the rescue of the occupants, Mercedes-Benz has developed further measures. These include the automatic engine cut-off or the activation of the hazard warning lamps and interior emergency illumination. The central locking also opens automatically, and crash joints between the door and the wing make it easier to open the doors after a head-on collision. In addition Mercedes-Benz makes Guidelines for Rescue Services available; helpers all over the world can download them in various languages from the internet at www.mercedes-benz.de/rettungsleitfaden. As you can see, at Mercedes-Benz consideration has been given to safety in every situation.

Multimedia systems

To drive in style, you also need quality entertainment and helpful navigation. Cue our outstanding entertainment electronics and excellent navigation systems



As well as displaying navigation data in high resolution, the large TFT display also optimises the display of web and multimedia content

COMAND Online (option). The multimedia system boasts a high-resolution 17.8 cm colour display. The system's functions include a radio, speed-sensitive volume control, the MUSIC REGISTER with a 10 GB hard disc and hard-disc navigation. What's more, it also includes free European map data updates for three years following initial registration. The best in entertainment is provided courtesy of the DVD player, which can play CDs and MP3 files as well as video and audio DVDs. The online function facilitates access to the internet and various Mercedes-Benz mobile services via an internet-capable mobile phone. This means that you can surf the internet freely when at a standstill and you can use various apps during the journey, such as weather, Google Street View, Facebook or the car park search. A USB connection, an Aux-in socket, a slot for SD memory cards and a Bluetooth® interface allow connection to external data storage media and a mobile phone. The system is operated using the central Controller and the buttons on the 3-spoke multifunction steering wheel. The LINGUATRONIC system allows you to control COMAND Online using voice entry.

Harman Kardon® Logic 7® surround sound system (option). The surround sound system with 450 watts is sure to make every one of your journeys an acoustic experience to savour. Twelve high-performance speakers and the Logic 7® multi-channel surround sound technology provide a three-dimensional sound impression. The automatic volume control adapts the sound in line with the car's current speed.



All you need for pure musical enjoyment: the Harman Kardon® Logic 7® surround sound system

Audio 20 with Bluetooth® interface, USB connection and Aux-in socket (standard). Includes a radio function as well as a CD player with MP3 capability. The system is controlled via the multifunction steering wheel and the TFT display with a screen diagonal of 14.7 cm. A mobile phone can be linked via Bluetooth® for hands-free operation. There are also numerous interfaces available.



Audio 20 with eight precisely tuned speakers for delivering outstanding sound

Becker® MAP PILOT (option). The Becker® MAP PILOT reliably gets you to your destination and has everything you look for in a sophisticated navigation system. It is installed in the glove compartment and can be simply controlled via the central Controller and the Audio 20 CD system's display. What's more, it can be further personalised by downloading updated map data and additional functions.

Assistance systems

The C-Class Coupé is designed to help you relax on the way to your destination. That's why it offers systems that can assist you and make your life easier in a wide range of traffic situations, for example when parking, when driving from city to city on roads with variable speed limits or when facing challenging road conditions



Speed Limit Assist shows the driver the current speed limit

Speed Limit Assist (included with the optional COMAND Online system). Speed Limit Assist can detect speed-limit signs and display them as symbols on the instrument cluster and in COMAND Online on the navigation screen. They remain displayed there until the speed restriction is lifted or changed. To this end, a windscreen-mounted camera monitors the area in front of the car on a permanent basis. The camera can filter out round traffic signs, be they speed-limit signs at the side of the road or on a gantry above the road. To detect the signs, the system also draws on the data stored in the navigation system's digital map, thus also enabling it to take account of the vehicle entering or leaving urban areas. Speed Limit Assist is especially helpful on routes with variable speed limits or road works.

Reversing camera (option). The reversing camera with a wide-angle lens monitors the area directly behind the car and sends the images to the COMAND display. It is activated when reverse gear is engaged, thus enhancing safety when reversing into a parking space. The reversing camera is only available in conjunction with COMAND Online.



The reversing camera makes it easier to perform many manoeuvres when space is at a premium

PARKTRONIC incl. Parking Guidance (option). PARKTRONIC can warn the driver automatically if space in front of or behind the car becomes tight when parking or manoeuvring. The system operates on the echo sounder principle. Sensors on the front and rear bumpers emit ultrasound signals which are then reflected by other vehicles or obstacles. A microcomputer calculates the current distance and informs the driver by means of displays in the instrument cluster and via acoustic signals. Parking damage can therefore be prevented.



Parking Guidance automatically calculates the length of parking spaces at speeds up to 35 km/h

Parking Guidance can help the driver when looking for a parking space and also when parking: ultrasonic sensors in the side front bumper can measure the length of parking spaces parallel to the car automatically if the car drives past at a speed of 35 km/h or less. Parking Guidance starts once a suitable space has been found and reverse gear has been engaged. It provides the driver with visual and acoustic instructions regarding the correct steering angle as well as the turn-in and turn-back points on the instrument cluster. If the car is not straight after the first reversing move, the system also helps the driver with the required manoeuvres.

Seats

The C-Class Coupé is fitted with specially designed coupé seats including integral head restraints and luxury individual rear seats. As well as being style-defining, the seat design offers extremely effective support, even during sporty driving, and perfect ergonomics



The standard-fit coupé seats are ergonomically designed. You can tell that they are made for a highly agile car: the C-Class Coupé

Coupé seats. Ergonomic coupé seats upholstered in a combination of ARTICO man-made leather and fabric await the driver and front passenger; ARTICO man-made leather or genuine leather upholstery is optionally available. Both the seat cushion height and the backrest inclination are electrically adjustable at the push of a button. Heated or climatized seats are available as optional extras.

Individual rear seats with integral head restraints. The lounge-like character of the interior is also reflected in the ergonomic, individual design of the rear seats with integral head restraints. An asymmetrically split and folding rear seat backrest is included as standard (except in the C 180 BlueEFFICIENCY). Convenience is further enhanced by the manually operated EASY-ENTRY system, which makes it easier to get into and out of the car.



Sheer comfort: it's easy for rear passengers to get into the car thanks to the EASY-ENTRY system, which moves the front seats fully forwards in one simple move

Memory package (option). This package extends the range of seat settings and, if several people drive the car, ensures that each driver can adopt their preferred sitting position quickly by calling up their own pre-programmed settings – for the driver's seat, steering column and exterior mirrors – at the touch of a button. In addition to this, the Memory package includes 4-way lumbar support for both the front seats.



The ergonomic driver's seat moves into the pre-programmed desired position at the touch of a button



C-Class Coupé Sport

The C-Class Coupé Sport – engineered by AMG – turns every bend into a special experience. For the sharpest cornering and lateral dynamics in its class the vehicle boasts an exclusively tuned AMG sports suspension. Acoustically, the rich sound of the sports exhaust system provides the backdrop for the powerful propulsion. The specially configured sports mode makes the engine react tangibly more directly, as it changes the shift points and shortens the response times with a double-declutching function. And when braking with the sports braking system the transmission actively shifts down. There is additional visual highlighting of what facilitates more sportiness and dynamism in technical terms. For the spoiler lip, AMG Styling and AMG light-alloy wheels clearly show what the vehicle proves on every journey: sporting perfection.

The C-Class Coupé Sport includes the AMG Plus Sports package and is rounded off by the following technical and design components:



C-Class Coupé Sport

AMG 7-twin-spoke light-alloy wheels, painted in high-gloss black and with a high-shine finish

AMG lowered sports suspension with set-up optimised for lateral dynamics

Exterior mirrors painted black

Radiator grille featuring twin louvres in high-gloss black with chrome trim

Sports exhaust system

Sports braking system with larger brake discs, including perforated front brake discs, callipers with "Mercedes-Benz" lettering

"Sport" label on the side wings

Sports-tuned engine and transmission in S/M mode

- Active downshifting when braking
- Gear changes with double-declutching function
- More agile accelerator pedal characteristics with more direct response
- Shorter shift times

Speed-sensitive sports steering with more direct ratio





C 63 AMG Coupé

The C 63 AMG is the epitome of an expressive coupé. The AMG front apron, the AMG radiator grille with one chrome louvre, the unique AMG bonnet with powerdomes, the unique AMG daytime running lamps, the side sill panels and the rear apron with inset diffuser are just some of the features that demonstrate its commitment to performance. The AMG sports exhaust with two chromed twin tailpipes likewise emphasises the high-performance credentials of the coupé and shows unequivocally that this particular Mercedes-Benz is powered by an AMG drive system. The exterior is completed to perfection by AMG light-alloy wheels, further underlining the fact that this is a highly responsive car built for motoring enjoyment. Further exterior features are listed below.

Exterior

AMG spoiler lip on the boot lid

AMG high-performance braking system with 360 x 36 mm front brake discs and 330 x 26 mm rear brake discs

AMG 5-twin-spoke light-alloy wheels, painted titanium grey with a high-sheen finish, with 235/40 R 18 front tyres and 255/35 R 18 rear tyres

AMG bodystyling, comprising front apron with side air outlets and cross strut in high-gloss black, side sill panels and diffuser-look rear apron

Distinctive, flared front wings with "6.3 AMG" lettering

Tail lights with LED technology



Powerful on the outside, stylish on the inside. The interior concept of the C 63 AMG Coupé is well thought-out, right down to the last detail. As soon as you open the doors, the AMG door sill panels tell you that this car is something truly special. Passengers are then welcomed by AMG sports seats upholstered in a combination of ARTICO man-made leather and DINAMICA microfibre in black or, as an option, designo leather (single-tone or two-tone). The AMG performance steering wheel, featuring flattened top and bottom sections, has aluminium shift paddles, while the AMG instrument cluster with a colour display and AMG Start-up indicator is in an ergonomically ideal position. The black headlining and the AMG sports pedals complete the sporty ambience.

→ www.mercedes-amg.com



Interior

AMG door sill panels in brushed stainless steel

AMG instrument cluster with 11.4 cm high-resolution colour display, incl. RACETIMER and AMG Start-up indicator

AMG performance sports steering wheel in nappa leather, with flattened top and bottom sections as well as silver-coloured aluminium gearshift paddles

AMG speed-sensitive sports steering

AMG sports seats in ARTICO man-made leather/DINAMICA microfibre in black

ATTENTION ASSIST

Rotary switch for selecting the four transmission modes and Race Start function

Brushed stainless-steel sports pedals with rubber studs

High-gloss black piano-lacquer-look trim

C 63 AMG technology

The AMG 6.3-litre V8 engine and the AMG SPEEDSHIFT MCT 7-speed sports transmission offer an emotive driving feel and driving dynamics at the highest level. But when it comes to choosing a sporty or comfort-oriented driving style, the driver always has the final say in the C-Class Coupé → www.mercedes-amg.com

AMG 6.3-litre V8 engine. A high-revving naturally aspirated engine with thoroughbred motor-racing technology: the vertical arrangement of the intake and exhaust ducts as well as the magnesium variable-intake manifold with two integral throttle valves ensure optimum charging of the eight cylinders. Further high-tech features include the variable camshaft adjustment, the four-valve-per-cylinder design, the stiff aluminium crankcase and the low-friction TWAS (twin-wire-arc-spraying) coating used for the cylinder walls. The V8 powerplant develops 336 kW (457 hp) at 6800 rpm, delivering impressive pulling power and a maximum torque of 600 Nm at 5000 rpm. Ideal ingredients for powerful acceleration in every engine speed range, as the driver always has over 500 Nm on tap between 2000 and 6250 rpm. Adding the AMG Performance package boosts the output by 22 kW (30 hp) to 358 kW (487 hp), enabling the car to accelerate from 0 to 100 km/h in a highly impressive 4.3 seconds.

AMG sports suspension. Superlative driving dynamics and thrilling driving enjoyment come courtesy of the AMG sports suspension with AMG 5-twin-spoke light-alloy wheels with 235/40 R 18 front tyres and 255/35 R 18 rear tyres in combination with the specially designed three-link front suspension with a wider track, the AMG speed-sensitive sports steering and the three-stage ESP®. The AMG speed-sensitive sports steering has an even more direct ratio and, therefore, offers greater steering precision at high cornering speeds. The AMG sports suspension's stiff springs, gas-pressure shock absorbers and unique axle kinematics provide optimum agility at the driving limits as well as outstanding lateral dynamics. The AMG sports suspension therefore combines driving dynamics at the highest level with hallmark Mercedes long-distance comfort – and thus displays the characteristic attributes of a true AMG. The Electronic Stability Program ESP® has been specially adapted in line with the high level of driving dynamics, as it allows the driver to select the level of assistance provided by the dynamic handling control system by choosing one of three different control settings: ON, OFF and SPORT HANDLING MODE. The activated setting

is shown on the AMG instrument cluster's central display. The AMG high-performance braking system featuring large, internally ventilated and perforated brake discs ensures outstanding levels of deceleration. Not to mention perfect brake control, extremely short stopping distances and excellent fade resistance.

Also available is the optional AMG performance suspension. With its sportier spring and damper tuning this suspension responds even faster and more directly to meet the very highest dynamic handling requirements.

AMG SPEEDSHIFT MCT 7-speed sports transmission.

Equipped with AMG aluminium steering-wheel gearshift paddles, four modes and a Race Start function, the 7-speed automatic transmission delivers enhanced driving dynamics and is highly efficient. The “S” (Sport), “S+” (Sport Plus), “C” (Comfort) and “M” (Manual) modes each have different gear-change characteristics and speeds: gear changes in “S” and “S+” modes are around 20 or 40 percent quicker than in “C” mode respectively – while in “M” mode gear changes take just 100 milliseconds, making them some 50 percent faster. A push of a button activates the desired driving mode: distinctly sporty or more comfort-oriented. There is also an automatic double-declutching function when downshifting, which provides an emotive sound experience as well as reducing power-off effects. This function has a positive effect when braking on the approach to bends in particular.



The AMG SPEEDSHIFT MCT 7-speed sports transmission offers customised modes for maximum driving pleasure



Motor-racing technology gives the AMG 6.3-litre V8 engine maximum agility





AMG Performance Studio

An even sportier look for the C 63 AMG is available in the AMG Performance Studio. The AMG Performance package, for example, includes an increased output of 22 kW (30 hp), the AMG performance steering wheel in nappa leather/DINAMICA microfibre, the AMG high-performance compound braking system at the front axle, the AMG carbon-fibre spoiler lip, brake callipers painted red at the front and rear, plus a variable intake manifold painted in titanium grey. Vehicle-specific data and route information can be visualised and evaluated using AMG Performance Media – a unique highlight for racing enthusiasts. The AMG Driver's Package increases the maximum speed of the vehicle to 280 km/h and includes a driver training session at the AMG Driving Academy. What's more, the AMG Performance Studio meets individual customer requirements – right down to one-off features.

AMG Performance Studio

AMG Exterior Carbon-Fibre package (AMG carbon-fibre spoiler lip and exterior mirror housings)

AMG door sill panels, illuminated with white LEDs

AMG floor mats

AMG rear-axle differential lock

AMG multi-spoke light-alloy wheels, painted titanium grey or matt black, with 235/35 R 19 tyres at the front and 255/30 R 19 tyres at the rear

AMG performance suspension

AMG Performance Media

AMG carbon-fibre trim

Standard equipment | Selection



Daytime running lamps and front fog lamps



3-spoke multifunction steering wheel with 4 buttons in nappa leather, perforated in the grip area



THERMATIC automatic climate control



Coupé seats



LED tail lights



Audio 20 CD



ECO start/stop function



USB connection and Aux-in socket

Optional extras | Selection



Heat-insulating tinted rear window and rear side windows



Panoramic sliding sunroof



3-spoke multifunction steering wheel with 12 buttons, in nappa leather, perforated in the grip area



KEYLESS-GO drive authorisation system



Intelligent Light System with Adaptive Highbeam Assist



Mirror package



COMAND Online multimedia system with LINGUATRONIC



Media Interface



AMG Sports package

The optionally available AMG Sports package lends the C-Class Coupé an even more dynamic and athletic appearance as well as enhancing its sporty agility. On the outside, it emphasises the coupé's visible forwards thrust with AMG 7-spoke light-alloy wheels and AMG bodystyling, including front and rear aprons as well as side sill panels. The AMG Sports package also includes sports suspension and speed-sensitive sports steering to emphasise the car's effortlessly superior agility.

Exterior

AMG 7-spoke light-alloy wheels with mixed-size tyres: 225/40 R 18 at the front and 255/35 R 18 at the rear

AMG bodystyling, comprising front apron, side sill panels and rear apron

Perforated front brake discs, brake callipers with "Mercedes-Benz" lettering

Tailpipe trim in polished stainless steel

Lowered sports suspension

Speed-sensitive sports steering



The unique features of the optionally available AMG Sports package lend the interior of the C-Class Coupé extra dynamic touches: the 3-spoke multifunction sports steering wheel with a flattened bottom section allows the driver to change gear using steering-wheel gearshift paddles (only in conjunction with automatic transmission), while the speed-sensitive sports steering enhances the car's sporty handling. The headlining is finished in black fabric. A generously sized instrument cluster with an 11.4 cm colour display and ATTENTION ASSIST catches the eye without distracting the driver's attention from the road. The sporty interior is rounded off perfectly by an aluminium trim, brushed stainless-steel sports pedals and AMG floor mats.



Interior

3-spoke multifunction sports steering wheel with flattened bottom section and 12 buttons, in nappa leather, perforated in the grip area

ATTENTION ASSIST

Brushed stainless-steel sports pedals with rubber studs

Dark longitudinal-grain aluminium trim

Floor mats in black with "AMG" lettering

Headlining in black

Instrument cluster with high-resolution 11.4 cm colour display

Steering-wheel gearshift paddles (only with automatic transmission)



AMG Plus Sports package

The dynamic lines of the C-Class become even more intensive with the AMG Plus Sports package. This brings out the sporty essence of the model by applying the inimitable AMG treatment in numerous areas. In specific terms this means: AMG bodystyling with front and rear aprons as well as side sill panels, an AMG spoiler lip in the vehicle colour on the boot lid and exclusive AMG 7-twin-spoke light-alloy wheels. The systematic application of the AMG treatment also extends to the details: perforated front brake discs, brake callipers with “Mercedes-Benz” lettering and polished stainless-steel tailpipe embellishers. But it is not just the vehicle’s looks that are enhanced. The speed-sensitive sports steering and sports suspension ensure that the driving dynamics deliver all that the appearance promises.

Exterior

AMG spoiler lip on the boot lid

AMG 7-twin-spoke light-alloy wheels, painted in high-gloss black and with a high-sheen finish

AMG bodystyling, comprising front apron, side sill panel and rear apron

Brake callipers with “Mercedes-Benz” lettering, perforated front brake discs

Lowered sports suspension

Speed-sensitive sports steering

Tailpipe trim in polished stainless steel



The sporty theme continues inside the vehicle: red topstitching on the AMG sports seats and red designo seat belts are complemented by silver-effect shift paddles on the 3-spoke multifunction sports steering wheel. Aluminium trim as well as black floor mats with “AMG” lettering and a red surround complete the interior, along with the brushed stainless-steel sports pedals. Together, these features add a distinctly sporty dimension to every trip – even the daily commute.

Interior

3-spoke multifunction sports steering wheel, with a flattened bottom section, with twelve buttons, in nappa leather and with contrasting topstitching in red, perforated in grip area

AMG floor mats in black with red surround

AMG sports seats with integral head restraints and single rear seats

Armrest, centre console, door centre panels and selector lever gaiter with contrasting topstitching in red

ATTENTION ASSIST

Dark longitudinal-grain aluminium trim

designo seat belts in red (can be deselected in favour of black seat belts)

Headlining in black

Instrument cluster with high-resolution 11.4 cm colour display

Sports pedals in brushed stainless steel with rubber studs (also for foot-operated parking brake)

Steering-wheel gearshift paddles, silver-coloured (only in conjunction with automatic transmission)

Upholstery in ARTICO man-made leather/DINAMICA microfibre in black or in black leather (option)



designo

The designo range allows you to design the C-Class Coupé to an even higher standard and to your own taste → www.mercedes-benz.com/designo

The wide range of exclusive designo appointments allows you to personalise an already exceptional vehicle. Single-tone appointments including seats and armrests in designo leather and leather-trimmed door centre panels featuring a hallmark designo look create a high-quality, exclusive atmosphere, whether you choose the designo leather in sand, black, porcelain or classic red. And should you wish to emphasise your coupé's individuality even more, designo offers plenty of further possibilities. An optional two-tone designo steering wheel offers the perfect complement to this exclusive designo interior.



The two-tone appointments in designo leather highlight the coupé's sporty, dynamic side. There is a choice of combinations available for the designo leather: sand/black, porcelain/black or classic red/black. As in all Mercedes-Benz models, the metal badge in the backrest is proof of meticulous material selection, exceptional quality, careful craftsmanship and individuality at the highest level. The interior is completed by the extended appointments in designo black leather comprising a leather finish for the upper section of the dashboard.



Style package

The Style package further emphasises the sporty and individual interior style of the C-Class Coupé

The Style package comprises a number of high-quality, harmoniously combined details. The upholstery in black ARTICO man-made leather with contrasting porcelain-coloured topstitching catches the eye straight away.



Handcrafted perfection: the Style package individualises the interior of the C-Class Coupé

The 3-spoke multifunction sports steering wheel with twelve buttons is trimmed in leather with a two-tone look, the lower section being finished in porcelain-coloured leather. The surface is perforated so that it is even easier to grip. This style is consistently matched by the trim, which is also in a porcelain colour but with a piano-lacquer look.



All the details add up to an impressive whole: the trim is in a shining porcelain piano-lacquer look

The armrests, the door panelling, the shift/selecter lever gaiter and the centre console are accentuated by contrasting topstitching in a porcelain colour, while the floor mats have porcelain-coloured edging.



Gearshift gaiter with porcelain-colour contrasting topstitching

Upholstery and trim



The seat upholstery in ARTICO man-made leather/fabric in black, included as standard, adds the perfect finishing touches to the coupé's seats. The 3-spoke multifunction steering wheel is trimmed in nappa leather, while the headlining is finished in alpaca grey fabric. The A-, B- and C-pillars are likewise in alpaca grey. Black is the colour used for the dashboard, the load compartment cover and the door panelling. A black piano-lacquer-look trim tastefully rounds off the interior design. The trim for the dashboard, centre console and doors is also optionally available in aluminium with a dark longitudinal grain or in matt brown ash wood.

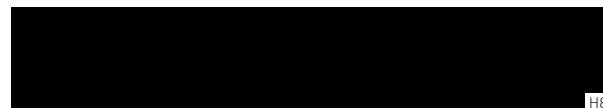
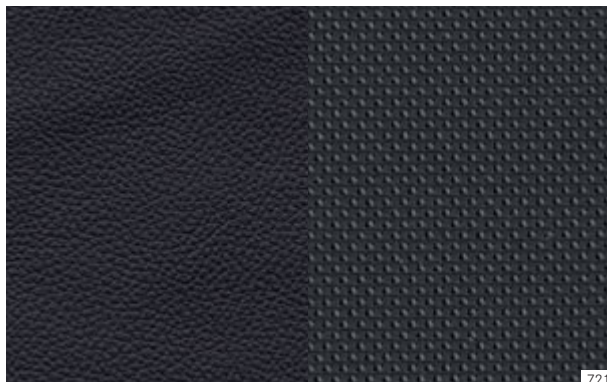

black

721 ARTICO man-made leather/fabric

Trim

H80 high-gloss black piano-lacquer look

739 dark longitudinal-grain aluminium¹

H06 matt brown ash wood¹

¹ Optional extra



The seat upholstery in ARTICO man-made leather/fabric in alpaca grey, included as standard, adds the perfect finishing touches to the coupé's seats. The 3-spoke multi-function steering wheel is trimmed in nappa leather, while the headlining is finished in alpaca grey fabric. The A-, B- and C-pillars and the door panelling are likewise in alpaca grey. The "split" dashboard is finished in black and alpaca grey, while the load compartment cover is black. A black piano-lacquer-look trim tastefully rounds off the interior design. The trim for the dashboard, centre console and doors is also optionally available in dark longitudinal-grain aluminium or in matt brown ash wood.

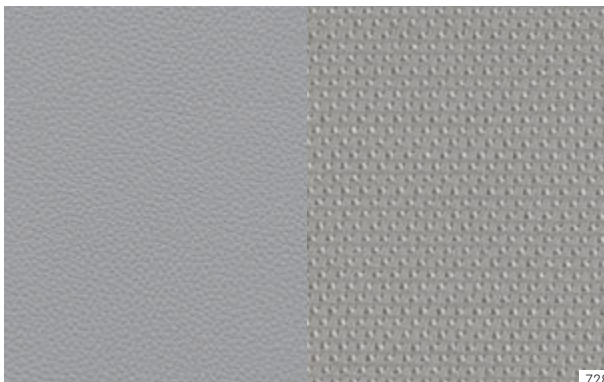

728



H80



739



H06

alpaca grey

728 ARTICO man-made leather/fabric

Trim

H80 high-gloss black piano-lacquer look

739 dark longitudinal-grain aluminium¹H06 matt brown ash wood¹¹ Optional extra



At the heart of the optional black colour scheme are the seats in a choice of black ARTICO man-made leather or black leather with alpaca grey topstitching. The 3-spoke multifunction steering wheel is trimmed in black nappa leather. The door panelling is also kept in black, while the headlining is finished in black fabric. The A-, B- and C-pillars, the dashboard and the load compartment cover are likewise in black. A dark aluminium trim tastefully rounds off the interior design. The trim for the dashboard, centre console and doors is also optionally available in a high-gloss black piano-lacquer look or in matt brown ash wood.

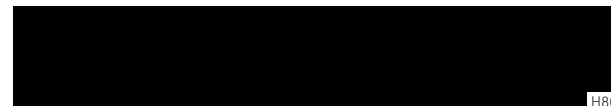
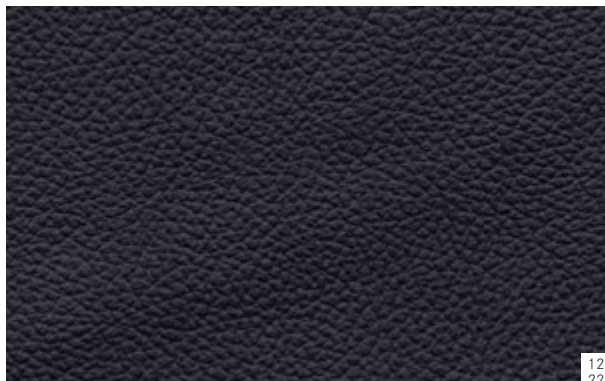

black

121 ARTICO man-made leather¹

221 leather¹

Trim

739 dark longitudinal-grain aluminium

H80 high-gloss black piano-lacquer look¹

H06 matt brown ash wood¹

¹ Optional extra



At the heart of the optional alpaca grey colour scheme are the seats in a choice of ARTICO man-made leather or leather in alpaca grey with dark alpaca grey topstitching. The 3-spoke multifunction steering wheel is trimmed in black nappa leather. The door panelling is kept in alpaca grey, while the load compartment cover is in black. The headlining is finished in black fabric, while the A-, B- and C-pillars are likewise in black. The “split” dashboard is finished in black and alpaca grey. A dark aluminium trim tastefully rounds off the interior design. The trim for the dashboard, centre console and doors is also optionally available in a high-gloss black piano-lacquer look or matt brown ash wood instead of aluminium.

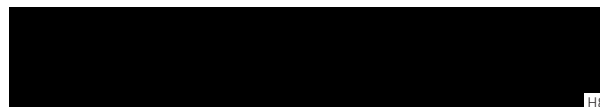
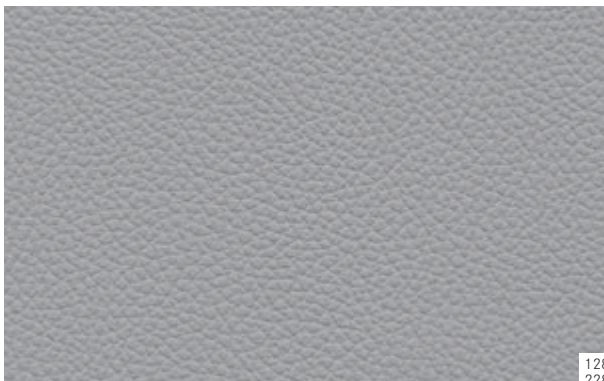

alpaca grey

128 ARTICO man-made leather¹

228 leather¹

Trim

739 dark longitudinal-grain aluminium

H80 high-gloss black piano-lacquer look¹

H06 matt brown ash wood¹

¹ Optional extra



At the heart of the optional saharabeige colour scheme are the seats in saharabeige leather with topstitching in the same colour. The 3-spoke multifunction steering wheel is trimmed in black nappa leather. The door panelling is kept in saharabeige, while the roof lining is finished in black fabric. The A-, B- and C-pillars, the dashboard and the load compartment cover are likewise in black. A dark aluminium trim tastefully rounds off the exclusive interior design. The trim for the dashboard, centre console and doors is also optionally available in a high-gloss black piano-lacquer look or in matt brown ash wood.

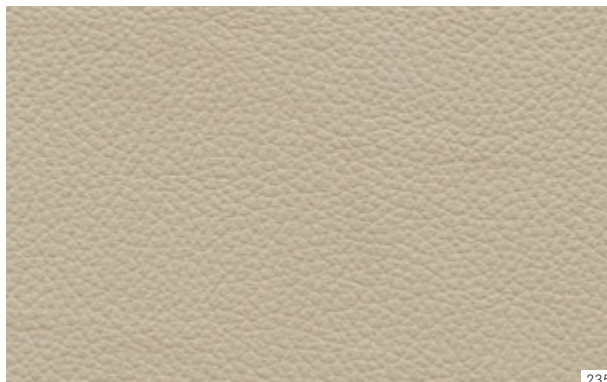

235



739



H80



H06

saharabeige

235 leather¹

Trim

739 dark longitudinal-grain aluminium

H80 high-gloss black piano-lacquer look¹H06 matt brown ash wood¹

¹ Optional extra



At the heart of the optional flamenco red colour scheme are the seats in flamenco red leather with black topstitching. The 3-spoke multifunction steering wheel is trimmed in black nappa leather. The door panelling is kept in flamenco red, while the headlining is finished in black fabric. The A-, B- and C-pillars, the dashboard and the load compartment cover are likewise in black. A dark aluminium trim tastefully rounds off the interior design. The trim for the dashboard, centre console and doors is also optionally available in a high-gloss black piano-lacquer look or in matt brown ash wood.

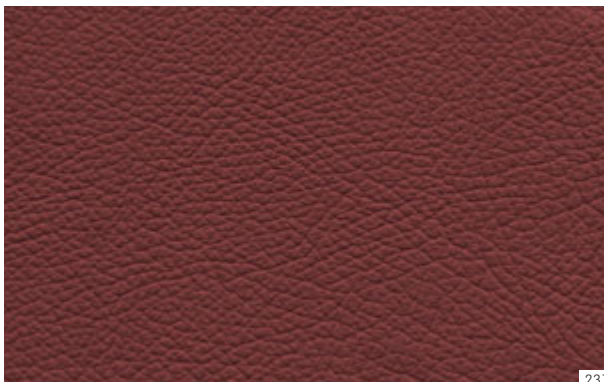

237



739



H80



H06

flamenco red
237 leather¹

Trim

739 dark longitudinal-grain aluminium

H80 high-gloss black piano-lacquer look¹H06 matt brown ash wood¹

¹ Optional extra

Wheels



5-spoke light-alloy wheels with 225/40 R 18 front and 255/35 R 18 rear tyres, in "sterling silver" (option, Code R36)



10-spoke light-alloy wheels with 225/45 R 17 tyres (standard for C 200 BlueEFFICIENCY, C 250 CDI BlueEFFICIENCY, C 250 BlueEFFICIENCY and C 350 BlueEFFICIENCY, Code 25R)



7-spoke light-alloy wheels with 225/45 R 17 front and 245/40 R 17 rear tyres, painted high-gloss black with a high-shine finish (optional, Code 74R)



5-twin-spoke light-alloy wheels with 225/45 R 17 front tyres and 245/40 R 17 rear tyres (optional, Code R95)



Multi-spoke light-alloy wheels with 225/45 R 17 front tyres and 245/40 R 17 rear tyres (optional, Code 56R)



7-spoke AMG light-alloy wheels with 225/40 R 18 front tyres and 255/35 R 18 rear tyres (standard wheels for AMG Sports package, Code 782)



7-spoke AMG light-alloy wheels with 225/40 R 18 front tyres and 255/35 R 18 rear tyres, painted in high-gloss black and with a high-sheen finish (optional for all Sports packages and Sport models, Code 661)



5-twin-spoke AMG light-alloy wheels, painted titanium grey with a high-sheen finish, with 235/40 R 18 front tyres and 255/35 R 18 rear tyres (standard for C 63 AMG, Code 795)



Multi-spoke AMG light-alloy wheels, painted titanium grey with a high-sheen finish, with 235/35 R 19 front tyres and 255/30 R 19 rear tyres (optional for C 63 AMG, Code 788)



7-twin-spoke AMG light-alloy wheels with 225/40 R 18 front tyres and 255/35 R 18 rear tyres, painted in titanium grey with a high-sheen finish (standard for AMG Plus Sports package and Sport models, Code 760)



5-twin-spoke AMG light-alloy wheels with 225/40 R 18 front tyres and 255/35 R 18 rear tyres (optional, Code 786)



5-spoke AMG light-alloy wheels, painted titanium grey with a high-sheen finish, with 235/40 R 18 front tyres and 255/35 R 18 rear tyres (optional for C 63 AMG, Code 790)



Multi-spoke AMG light-alloy wheels, painted matt black, rim flange with a high-sheen finish, with 235/35 R 19 front tyres and 255/30 R 19 rear tyres (optional for C 63 AMG, Code 797)



Basic carrier bars and Mercedes-Benz roof box

Genuine accessories

The C-Class Coupé is a very special car. The extensive range of Mercedes-Benz genuine accessories enables you to add further high-quality individuality
→ www.mercedes-benz-accessories.com

With genuine accessories from Mercedes-Benz, the C-Class Coupé can be made to reflect its owner's personal lifestyle. Those who like to travel with lots of luggage or sports equipment can add further stowage space by opting for the reliable and flexible carrier system and a 450 roof box which is easy to load and unload. The roof box is available in a choice of two sizes: the family box which holds around 450 litres or the sports box with a capacity of around 330 litres. Both boxes can be opened on both sides. Optional extras include a luggage set and a ski rack attachment.



Roof rack with "Luxury" ski and snowboard rack

A car as individual as the C-Class Coupé greets you every time you get in and out: with white-illuminated "Mercedes-Benz" lettering on the polished stainless-steel door sill panels.

Thanks to their distinctive styling, the high-end-design light-alloy wheels further emphasise the individual aura of the C-Class Coupé. These light-alloy wheels are available in a choice of sizes and designs, for example 5-twin-spoke wheels with mixed-size tyres: 225/40 R 18 at the front and, optionally, 255/35 R 18 at the rear.



Illuminated door sill panels with "Mercedes-Benz" lettering

The range of genuine accessories offers a wide selection of high-quality products to choose from. Please see our accessories brochure for further details, or contact your Mercedes-Benz dealer who will be pleased to advise you.



5-twin-spoke light-alloy wheels¹ (genuine accessories range)

¹ Light-alloy wheels from the genuine accessories range are supplied without tyres

Services

MercedesCard. As a VISA credit card, this is an internationally accepted means of payment that can offer you a host of additional benefits, such as the Mercedes-Benz insurance package or other exclusive insurance products. There's also the Mercedes-Benz magazine to inspire you with its fascinating features and reports. Further details are available from your Mercedes-Benz dealer.

Mercedes-Benz Financial Services. Mercedes-Benz stands for quality, innovation and safety – and the same applies to Mercedes-Benz Financial Services. Our innovative leasing and financing products are tailored to your financial needs and means, making it easy for you to secure the keys to your dream car. Once you are on the road, our insurance products offer you comprehensive protection on every trip. Finally, our service products ensure that your car is always in tip-top condition while keeping costs transparent and easily manageable. For a detailed quotation, please contact your authorised Mercedes-Benz dealer, who will be pleased to go through the latest financial services and terms and conditions with you.

Mercedes-Benz mobility. Your new car comes complete with the promise of feeling safe on the road. But if you should ever need assistance, Mercedes-Benz Service24h is there to help. Just call the freephone service hotline on 00800 1 777 7777¹. The integrated telematics service, Mercedes-Benz Contact², is even more convenient: a touch of a button is all it takes to contact the Mercedes-Benz customer centre. If you wish, relevant vehicle and position-related data are transmitted at the same time, thereby allowing the centre to react quickly and provide rapid on-site assistance. Also standard with your new car at no extra charge is the Mercedes-Benz Mobilo³ mobility package. Whether you have lost your key, had a breakdown which cannot be repaired immediately or suffered damage to the vehicle due to an accident or vandalism, Mobilo helps you reach your destination – anywhere in Europe. Whatever is holding you up, you will soon be able to resume your journey.

Mercedes-Benz Museum. Discover what has been moving the world for over 125 years, and embark on a fascinating journey through automotive history in the Mercedes-Benz Museum. More than 1500 exhibits covering an area of 16,500 square metres chart the unique heritage and innovative flair of the inventor of the motor car. From the very

first model through to the very latest, you will find one legendary car after another awaiting you. The museum is a spectacular sight in its own right too, thanks to an architecture that breaks away from traditional concepts and creates an unprecedented sense of space. Welcome to the Mercedes-Benz Museum – a world of innovation. www.mercedes-benz-classic.com/museum

Test drive. The unique feeling of driving a Mercedes cannot be put into words – you have to experience it for yourself. Take a test drive and find out first hand how it feels to drive your dream car. Please contact your nearest Mercedes-Benz dealer for details.



¹ Alternative: +49 69 95 30 72 77 ² Requires a factory-fitted radio, connected to an operational mobile phone. The only charge incurred is the cost of the mobile phone call to the landline network ³ Once the mobility guarantee has expired (four years), Mobilo can be extended to provide cover in the event of breakdown and insurance claims one year at a time for a maximum of 30 years, provided that regular maintenance is carried out by your Mercedes-Benz service partner

Interactive Owner's Manual and Mercedes-Benz Guides.

The website also offers an interactive tour, enabling you to acquaint yourself with your dream car. You can view key functions in detail, gain an insight into the car's inner workings or look at the benefits of each model. For further details, go to www.mercedes-benz.de/owners-manual. The "Mercedes-Benz Guides" app lets you explore the highlights of the individual models both online and offline. The app is available free of charge from the Apple® iTunes® Store (iOS) as well as the Google Play store (Android).

Mobile internet. The entire world of Mercedes-Benz can be accessed at any time with your web-capable mobile device - including specially adapted content for both smartphones and tablets. As well as an overview of all the passenger car models, there are insights into the entire brand world along with a wealth of entertainment offers and direct links to our range of services at www.mercedes-benz.com

Mercedes-Benz service contracts. Vehicle-specific service contracts allow you to arrange individual cover for your Mercedes: for a small monthly premium, the Excellent service contract covers all service jobs including maintenance, wear and repairs for up to five years. Simply present your service card and you will be safe from any unwelcome financial surprises - and you can relax in the knowledge that your Mercedes will stay on top form for a long time to come. The Advance service contract provides a warranty extension, so you will be protected against unexpected repair costs even after the manufacturer's warranty or the Excellent service contract has expired - for up to ten years.



Accident repairs. Should the worst happen and you find yourself in need of repairs, with the Mercedes-Benz accident repair service you will receive the best possible assistance for your vehicle and ensure that its high-quality safety features are properly maintained. Whether you need paint, body or glass repair work carried out, the highly trained specialists at your Mercedes-Benz service partner will repair your Mercedes-Benz and get you quickly back on the road again. Further information is available from your authorised Mercedes-Benz dealer.



Dimensions

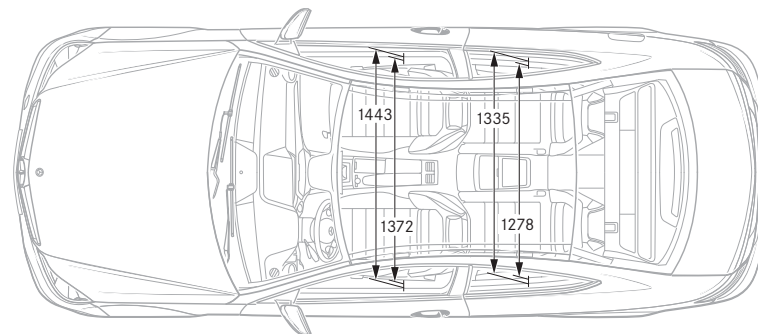
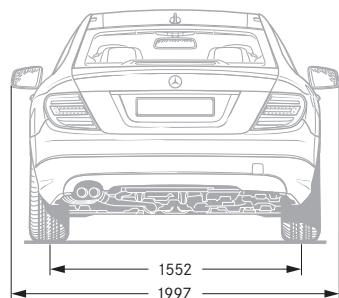
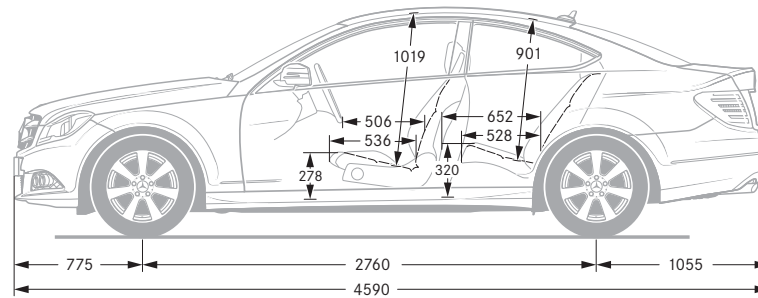
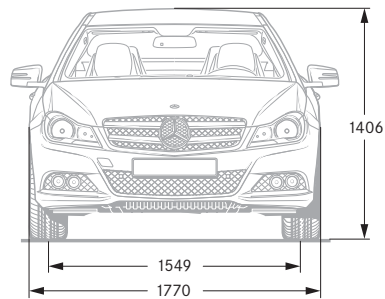

Paintwork

The paint system developed by Mercedes-Benz includes one of the best clearcoats on the automotive market and is a key factor behind the car's excellent value retention. The secret lies in the exceptionally dense molecular structure, which makes both the metallic and the non-metallic clearcoats more resistant and produces a longer-lasting and visibly more intensive shine.

Non-metallic paints (standard)

- 040 black
- 149 polar white
- 590 fire opal

Metallic paints (option)

- 183 magnetite black
- 197 obsidian black
- 755 tenorite grey
- 775 iridium silver
- 792 palladium silver
- 890 cavansite blue
- 988 diamond silver

Special paints (option)

- 051 designo magno platinum (option for C-Class Coupé Sport)
- 799 diamond white metallic BRIGHT

Technical data

	Diesel engines			
	C 220 CDI BlueEFFICIENCY	C 220 CDI BlueEFFICIENCY Edition	C 250 CDI BlueEFFICIENCY	C 250 CDI Sport
No. of cylinders/arrangement	4/in-line	4/in-line	4/in-line	4/in-line
Total displacement in cc	2143	2143	2143	2143
Rated output ¹ in kW (hp) at rpm	125 (170)/3000-4200	125 (170)/3000-4200	150 (204)/4200	150 (204)/4200
Rated torque in Nm at rpm	400/1400-2800	400/1400-2800	500/1600-1800	500/1600-1800
Acceleration from 0 to 100 km/h in s	8.4 [8.1]	8.4	7.0 [7.1]	- [7.1]
Top speed, approx. in km/h	232 [231]	232	240 [240]	- [240]
Tyre size – front axle, rear axle	205/55 R 16	205/55 R 16	225/45 R 17	225/40 R 18, 255/35 R 18
Fuel	Diesel fuel	Diesel fuel	Diesel fuel	Diesel fuel
Fuel consumption ³ in l/100 km				
Urban	6.3-5.6 [6.5-6.1]	5.2	6.8-6.2 [6.5-6.1]	- [6.5]
Extra-urban	4.3-3.7 [4.6-4.2]	3.5	4.6-4.1 [4.6-4.2]	- [4.6]
Combined	5.1-4.4 [5.3-4.9]	4.1	5.4-4.9 [5.3-4.9]	- [5.3]
CO ₂ emissions ³ in g/km combined	133-117 [139-128]	109	143-128 [139-128]	- [139]
Emission class	Euro 5	Euro 5	Euro 5	Euro 5
Tank capacity in l/of which reserve approx.	59/8	59/8	59/8	59/8
Boot capacity in l	450	450	450	450
Turning circle diameter in m	10.84	10.84	10.84	10.84
Kerb weight ⁴ in kg	1615 [1630]	1615	1655 [1660]	- [1660]
Perm. GVW in kg	2085 [2100]	2085	2125 [2130]	- [2130]

¹ Figures in accordance with Directive 80/1269/EEC in the currently applicable version ² Electronically governed ³ The figures shown were obtained in accordance with the prescribed measuring process (Directive [EC] 715/2007 in the currently applicable version in each case). The figures are not based on an individual model and do not constitute part of the product offer; they are provided solely for purposes of comparison between different vehicle models

Petrol engines

C 180	C 200	C 250	C 250 Sport	C 350	C 63 AMG	
BlueEFFICIENCY	BlueEFFICIENCY	BlueEFFICIENCY		BlueEFFICIENCY	Without Performance package	With Performance package
4/in-line	4/in-line	4/in-line	4/in-line	6/V	8/V	8/V
1595	1796	1796	1796	3498	6208	6208
115 (156)/5300	135 (184)/5250	150 (204)/5500	150 (204)/5500	225 (306)/6500	336 (457)/6800	358 (487)/6800
250/1250-4000	270/1800-4600	310/2000-4300	310/2000-4300	370/3500-5250	600/5000	600/5000
8.5 [8.5]	8.2 [7.8]	- [7.2]	- [7.2]	- [6.0]	- [4.4]	- [4.3]
225 [223]	237 [235]	- [240]	- [240]	- [250] ²	- [250] ²	- [250] ²
195/60 R 16	225/45 R 17	225/45 R 17	225/40 R 18, 255/35 R 18	225/45 R 17	235/40 R 18, 255/35 R 18	235/40 R 18, 255/35 R 18
Premium petrol	Premium petrol	Premium petrol	Premium petrol	Premium petrol	Super Plus petrol	Super Plus petrol
8.1-7.7 [8.0-7.7]	9.8-9.3 [9.1-8.8]	- [9.1-8.8]	- [9.1]	- [9.6-9.4]	- [18.2]	- [18.2]
5.4-4.7 [5.3-4.8]	5.8-5.2 [5.7-5.2]	- [5.7-5.2]	- [5.7]	- [5.6-5.3]	- [8.4]	- [8.4]
6.4-5.8 [6.3-5.8]	7.2-6.6 [7.0-6.5]	- [7.0-6.5]	- [7.0]	- [7.0-6.8]	- [12.0]	- [12.0]
149-136 [147-136]	168-154 [163-152]	- [163-152]	- [163-152]	- [164-159]	- [280]	- [280]
Euro 5	Euro 5	Euro 5	Euro 5	Euro 5	Euro 5	Euro 5
59/8	59/8	59/8	59/8	66/8	66/14	66/14
450	450	450	450	450	450	450
10.84	10.84	10.84	10.84	10.84	11.10	11.10
1490 [1505]	1540 [1545]	- [1550]	- [1550]	- [1615]	- [1730]	- [1730]
1960 [1975]	2010 [2015]	- [2020]	- [2020]	- [2085]	- [2160]	- [2160]

⁴ Figures according to Directive 92/21/EC, version 95/48/EC (kerb weight with fuel tank 90% full, driver, 68 kg, and luggage, 7 kg) for standard-specification vehicles. Optional extras and accessories will generally increase this figure and reduce the payload capacity accordingly. Figures in square brackets apply to vehicles with an automatic transmission. Further technical data can be found at www.mercedes-benz.com

Non-metallic paints

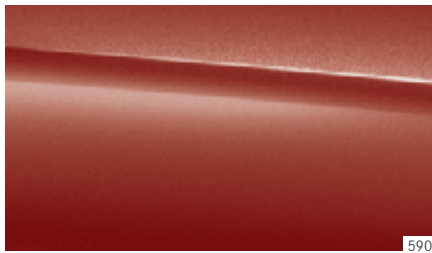
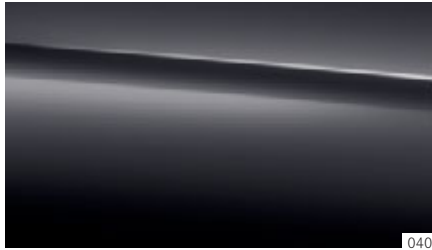

Metallic paints

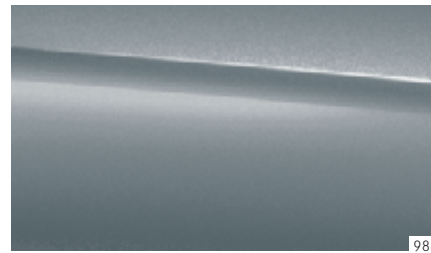
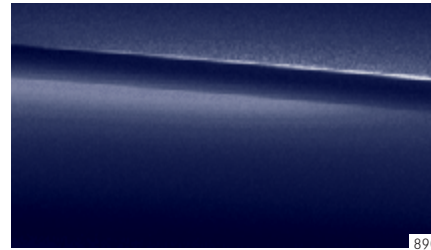
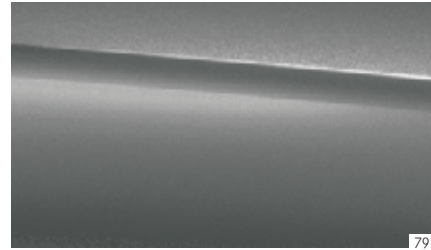
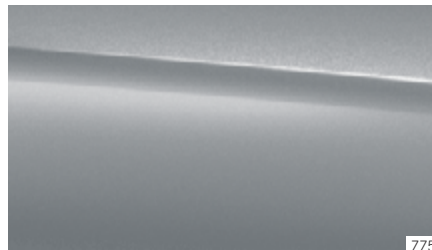
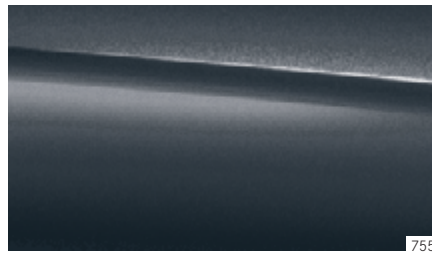
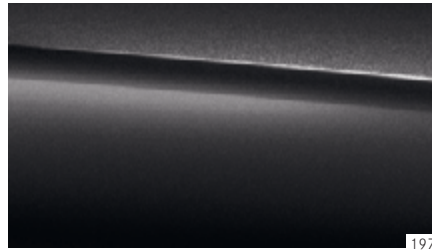
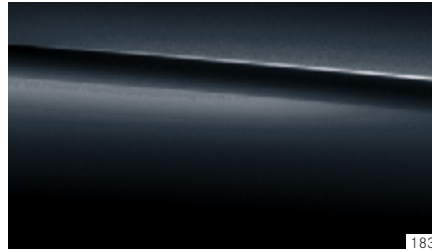

Special paints

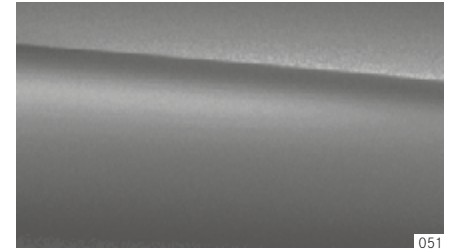

Take-back of end-of-life vehicles. You can return your C-Class to us for environment-friendly disposal in accordance with the European Union (EU) End-Of-Life Vehicle Directive. But that day lies a long way off.

A network of vehicle take-back depots and dismantlers has been established to make it as easy as possible for you to return your vehicle. You can leave it at any of these points free of charge and, by doing so, make an important contribution to completing the recycling process and conserving resources.

For further information about the recycling and disposal of end-of-life vehicles, and the take-back conditions, please visit the national Mercedes-Benz website for your country.

Please note: changes may have been made to the product since this brochure went to press (20.07.2012). The manufacturer reserves the right to make changes to the design, form, colour and specification during the delivery period, provided these changes, while taking into account the interests of the vendor, can be deemed reasonable with respect to the purchaser. Where the vendor or the manufacturer uses symbols or numbers to describe an order or the subject of an order, no rights may be derived solely from these. The illustrations may show accessories and items of optional equipment which are not part of standard specification. Colours may differ slightly from those shown in the brochure, owing to the limitations of the printing process. This brochure is distributed internationally. It provides a general indication of the range of models, features, optional extras and colours available in various countries. Some of the models, features, optional extras and colours shown may not be available in your country or may only be available in a different specification. Additionally some models, features, optional extras and colours may only be available in combination with others. For current and more specific information in relation to the range of models, features, optional extras and colours available in your country, and their pricing, you should contact your nearest authorised Mercedes-Benz Passenger Car Dealer.

www.mercedes-benz.com